



WASHING MACHINE SERVICE MANUAL

⚠ CAUTION

READ THIS MANUAL CAREFULLY TO DIAGNOSE
PROBLEMS CORRECTLY BEFORE SERVICING THE UNIT.

**MODEL : GCWM1069CS7
GCWM1069CD7
GCWM1069QS7
GCWM1069QD7**

Any reproduction, duplication, distribution (including by way of email, facsimile or other electronic means), publication, modification, copying or transmission of this Service Manual is **STRICTLY PROHIBITED** unless you have obtained the prior written consent of the LG Electronics entity from which you received this Service Manual. The material covered by this prohibition includes, without limitation, any text, graphics or logos in this Service Manual.

Copyright © 2020 LG Electronics Inc. All rights reserved. Only training and service purposes.

CONTENTS

1. IMPORTANT SAFETY INSTRUCTIONS	3
2. SPECIFICATIONS	4
3. FEATURES AND TECHNICAL EXPLANATION	5~6
4. PARTS IDENTIFICATION.....	7
5. INSTALLATION INSTRUCTIONS	8~14
6. OPERATION	15~17
7. WIRING DIAGRAM/PROGRAM CHART/PCB LAYOUT	18~20
8. TROUBLESHOOTING	21~24
8-1. BEFORE PERFORMING SERVICE.....	21
8-2. QC TEST MODE	21
8-3. HOW TO CHECK THE WATER LEVEL FREQUENCY.....	21
8-4. HOW TO CHECK THE RPM	21
8-5. ERROR DISPLAY.....	22~23
8-6. DISPENSER	24
9. DIAGNOSIS AND TROUBLESHOOTING.....	25~42
10. SMART FUNCTIONS	43~44
11. DISASSEMBLY INSTRUCTIONS	45~53
12. EXPLODED VIEW.....	54~57
12-1. CABINET & CONTROL PANEL ASSEMBLY.....	54
12-1-1. CABINET & CONTROL PANEL ASSEMBLY - CARD TYPE.....	55
12-2. DRUM & TUB ASSEMBLY.....	56
12-3. DISPENSER ASSEMBLY (FOR SINGLE MODEL)	57

1. IMPORTANT SAFETY INSTRUCTIONS

READ ALL INSTRUCTIONS BEFORE USE

WARNING

For your safety, the information in this manual must be followed to minimize the risk of fire or explosion, electric shock, or to prevent property damage, injury to persons, or death.

IMPORTANT SAFETY INSTRUCTIONS

 **WARNING** : To reduce the risk of fire, electric shock, or injury to persons when using the washer, follow basic precautions, including the following:

- Read all instructions before using the washer.
- Do not wash articles that have been previously cleaned in, washed in, soaked in, or spotted with gasoline, dry cleaning solvents, or other flammable or explosive substances, as they give off vapors that could ignite or explode.
- Do not add gasoline, dry cleaning solvents, or other flammable or explosive substances to the wash water. These substances give off vapors that could ignite or explode.
- Under certain conditions, hydrogen gas may be produced in a hot water system that has not been used for 2 weeks or more. **HYDROGEN GAS IS EXPLOSIVE.** If the hot water system has not been used for such a period, before using the washing machine, turn on all hot water faucets and let the water flow from each for several minutes. This will release any accumulated hydrogen gas. As the gas is flammable, do not smoke or use an open flame during this time.
- Do not allow children to play on or in the washer. Close supervision of children is necessary when the washer is used near children.
- Before the washer is removed from service or discarded, remove the door to prevent children from hiding inside.
- Do not install or store the washer where it will be exposed to the weather.
- Do not tamper with controls.
- Do not repair or replace any part of the washer or attempt any servicing unless specifically recommended in the user-maintenance instructions or published user-repair instructions that you understand and have the skills to carry out.
- See Installation Instructions for grounding requirements.
- **ALWAYS** follow the fabric care instructions supplied by the garment manufacturer.
- Do not place items exposed to cooking oil in your washer. Items contaminated with cooking oils may contribute to a chemical reaction that could cause a load to catch fire.
- Do not use fabric softeners or products to eliminate static unless recommended by the manufacturer of the fabric softener or product.

SAVE THESE INSTRUCTIONS

GROUNDING INSTRUCTIONS

This appliance must be grounded. In the event of malfunction or breakdown, grounding will reduce the risk of electric shock by providing a path of least resistance for electric current. This appliance is equipped with a cord having an equipment-grounding conductor and grounding plug. The plug must be plugged into an appropriate outlet that is properly installed and grounded in accordance with all local codes and ordinances.

- Do not use an adapter or extension cord.
- Do not remove ground prong.
- If you don't have the proper outlet, consult an electrician.

 **WARNING:** Improper connection of the equipment-grounding conductor can result in risk of electric shock. Check with a qualified electrician or serviceman if you are in doubt as to whether the appliance is properly grounded. Do not modify the plug provided with the appliance - if it does not fit the outlet, have a proper outlet installed by a qualified electrician.

2. SPECIFICATIONS

MODEL		GCWM1069CS7/GCWM1069CD7 GCWM1069QS7/GCWW1069QD7
COLOR	BLUE WHITE	STAINLESS SILVER
POWER SUPPLY	120V, 60Hz	
PRODUCT WEIGHT	190 lbs. (87kg)	
CURRENT CONSUMPTION	WASHING	7A (Tub Clean : 9A)
ELECTRIC POWER CONSUMPTION	DRAIN MOTOR	45W
	CIRCULATION MOTOR	45W
FUSE	250V, 12A (Time Delay)	
REVOLUTION SPEED	WASH	45 rpm
	SPIN	1200
CYCLES	4	
OPTIONS	ADD SUPER WASH Cycle (OPL:Custom PGM)	
OPERATIONAL WATER PRESSURE	20 - 120 psi (138 ~ 827 kPa)	
CONTROL TYPE	Electronic	
WASH CAPACITY	3.7 cu.ft (IEC : 4.2 cu.ft)	
DIMENSIONS	70 cm (W) X 77cm (D) X 98.3 cm (H), 139.6 cm (D with open)	
DOOR SWITCH TYPE	PTC + Solenoid	
WATER LEVEL	10 steps (by sensor)	
LAUNDRY LOAD SENSING	Incorporated	
ERROR DIAGNOSIS	Incorporated	
Wi-Fi	LG Landry Lounge (Web site) LG Laundry Lounge Installer (App) LG Laundry Lounge (End-User App)	

3. FEATURES & TECHNICAL EXPLANATION

3-1. FEATURES

■ Direct Drive System

The advanced Brushless DC motor directly drives the drum without belt and pulley.

■ The Tilted Drum and Extra Large Door Opening

Tilted drum and extra large door opening make it possible to load and unload easily.

■ Ultra Capacity

The larger drum enables not just higher head drop and stronger centrifugal force, but also less tangling and wrinkling of the laundry. Heavier loads, such as king size comforters, blankets, and curtains, can be washed.

■ SEE-THROUGH DOOR AND BIG DOOR

You can see the laundry throughout the cycle.

■ Magnetic Door Plunger

Safely and conveniently secure the door slightly ajar with the magnetic door plunger. This will promote air circulation and allow the interior of the machine to dry. To use this feature, after the load has been removed, do not close the door completely. When the magnetic door plunger comes into contact with the metal washer cabinet, it will secure the door slightly open allowing the interior of the washer to dry.

■ STAINLESS STEEL DRUM

Stainless steel drum offers extreme durability.

■ TUB CLEAN

Regular cleaning of the tub on a monthly basis using TUB CLEAN can help keep the tub clean and fresh.

■ LG Laundry Lounge Apps

- LG Laundry Lounge Installer : This is a registration app for installers used to register the product on the server. Only available for authorized users.

*Search for LG Laundry Lounge Installer in Google Play Store or Apple App Store.

- LG Laundry Lounge : This is for end-users to check real-time monitoring of registered stores and products.

*Search for LG Laundry Lounge in Google Play Store or Apple App Store.

3-2. WATER LEVEL CONTROL

- This model incorporates a pressure sensor which can sense the water level in the tub.
- The water supply is stopped when the water level reaches the preset level; then the selected cycle begins.
- Spinning does not proceed until the water in the tub drains to a certain level.

3-3. DOOR CONTROL

- The door can be opened by pulling the door handle whenever washer is not in operation.
- When the cycle is completed, the DOOR LOCKED light will turn off.
- If a power failure has occurred while in operation, the door will unlock after 2 minutes.
- Clicking sounds can be heard when the door is locked/unlocked.

3-4. THE DOOR CAN NOT BE OPENED

- While program is operating.
- While Door Lock lights turn on.
- While the drum is rotating.

3-5. DOOR LOCKED LAMP LIGHTS

- When the frequency of water level is lower than 22.9 kHz.
(It can be canceled when the frequency is more than 23.8 kHz.)
- When the temperature inside the tub is higher than 45 °C (104 °F) and water level is not 25.5 kHz.
(It can be canceled when the water level is 25.5 kHz or the temperature inside the tub is lower than 40 °C (113 °F).)

4. PARTS IDENTIFICATION

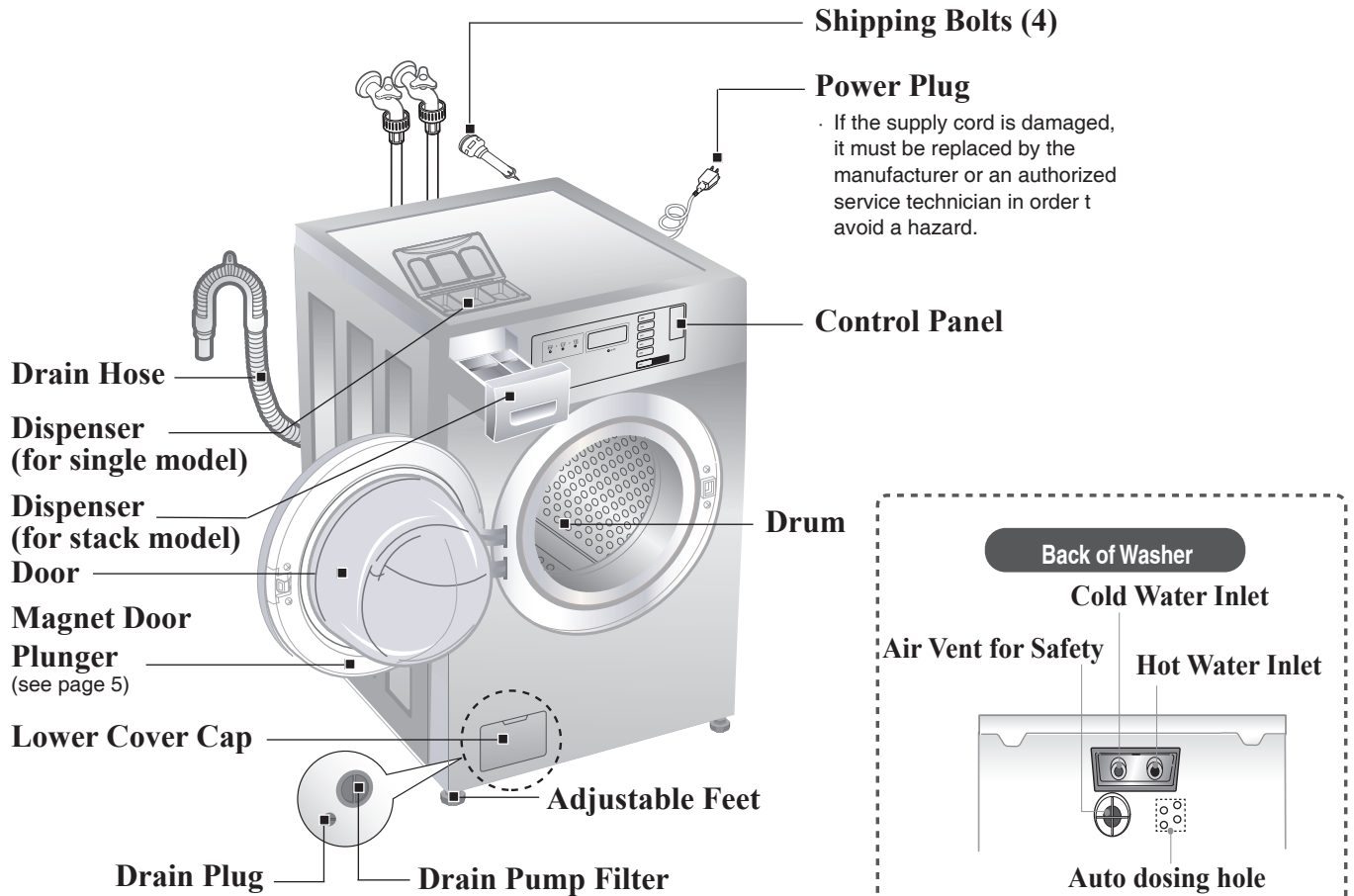

Shipping Bolts (4)

Power Plug

If the supply cord is damaged, it must be replaced by the manufacturer or an authorized service technician in order to avoid a hazard.

Control Panel

Drum

Back of Washer

Cold Water Inlet

Air Vent for Safety

Hot Water Inlet

Auto dosing hole

- Name: Front-loading Washing Machine
- Power supply: 120V, 60Hz
- Size: 70 cm (W) X 77 cm (D) X 98.3 cm (H), 139.6 cm (D with door open)
27"(W) X 30 1/4"(D) X 38 11/16"(H), 52"(D with door open)
- Weight: 190 lbs. (87 kg)
- Wash capacity: 3.7 cu.ft (IEC:4.2 cu.ft)
- Spin speed: 1200 rpm max.
- Permissible water pressure: 20 - 120 psi (138 ~ 827kPa)

Note

Specifications subject to change by manufacturer.

■ **Accessories**

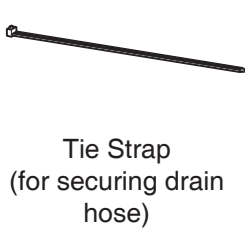
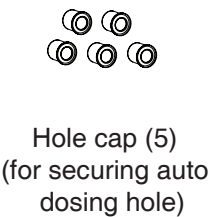
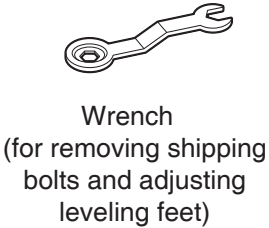
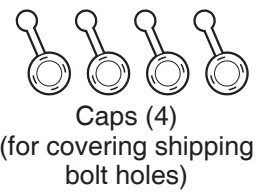

5. INSTALLATION INSTRUCTIONS

⚠ WARNING

- **Washer is heavy.** Two or more people may be needed to install and move the appliance. Failure to do so can result in back or other injury.
- **Store and install the washer where it will not be exposed to temperatures below freezing or exposed to outdoor weather conditions.** Failure to follow this warning can cause serious injury, fire, electric shock, or death.
- **This appliance must be properly grounded for personal safety.** Properly ground washer to conform with all governing codes and ordinances. Failure to follow this warning can cause serious injury, fire, electric shock, or death.
- **Do not install the washer in humid spaces to reduce the risk of electric shock.** Failure to follow this warning can cause serious injury, fire, electric shock or death.
- The base opening must not be obstructed by carpeting when the washer is installed on a carpeted floor.
- **Do not remove ground prong.** Do not use an adapter or extension cord. Plug into a grounded 3 prong outlet. Failure to follow this warning can cause serious injury, fire, electric shock or death.
- **Keep the area underneath and around your appliances free of combustible materials such as lint, paper, rags, chemicals, etc.** Failure to do so can result in fire.
- To reduce the risk of injury to persons, adhere to all industry recommended safety procedures including the use of long sleeved gloves and safety glasses. Failure to follow all of the safety warnings in this manual could result in property damage, injury to persons or death.

■ Shipping bolts

The appliance is fitted with shipping bolts to prevent internal damage during transportation. Packing and all shipping bolts must be removed before using the washer.

※ When unpacking the base, be sure to remove the additional packing support in the middle of the base packing.

■ Removing shipping bolts

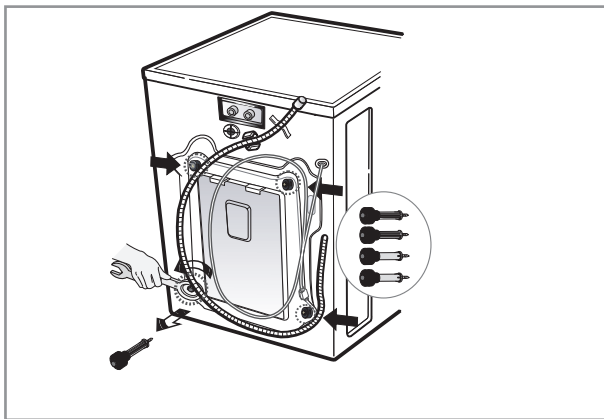

Unscrew the 4 bolts with the wrench supplied
Take out the 4 bolts by twisting the braces slightly

※ Keep the 4 bolts and the wrench for future use
(Whenever the appliance is transported, the shipping bolts and braces must be replaced.)

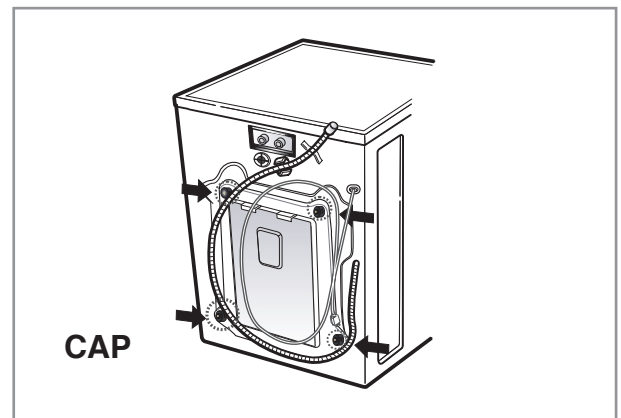
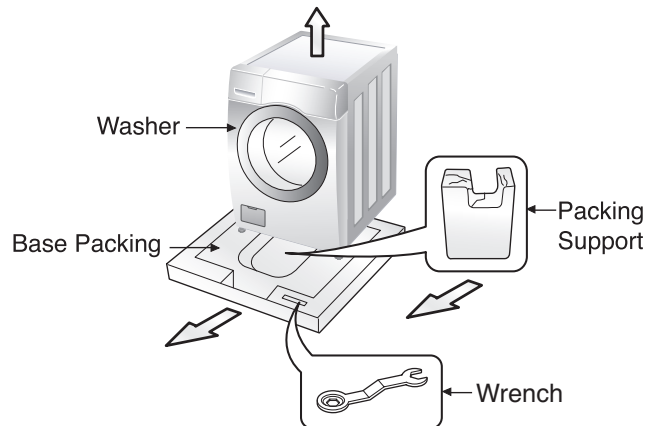

Close the holes with the caps supplied.

■ Installation clearances

The location must be large enough to open the washer door completely.

■ Washer dimensions

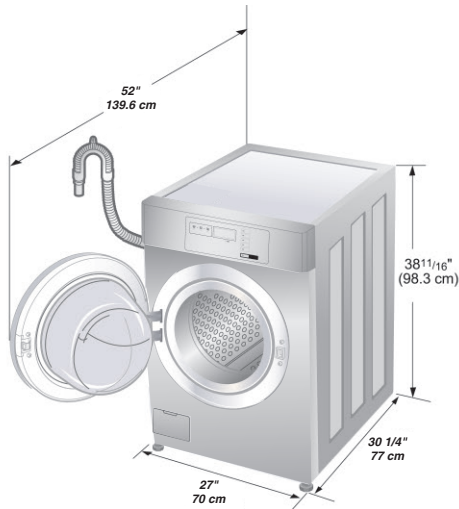

The following dimensions shown are for the minimum spacing allowed.

Additional spacing should be considered for installation and servicing.

- Additional clearances might be required for wall, door, and floor moldings.
- Additional spacing of 4" (10 cm) on back, 1" (2.5 cm) on all sides of the washer is recommended to reduce noise transfer.

Companion appliance spacing should also be considered.

■ Minimum installation spacing for recessed area installation.



Side view

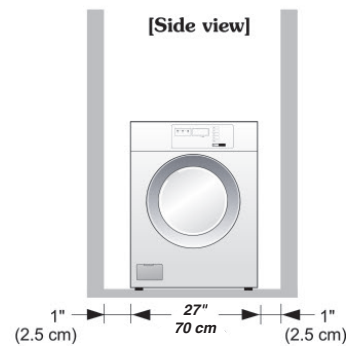

Front view

■ Installation of Auto dosing system

CH	Detergent	Input period
①	Pre-wash	Pre - wash phase
②	Main wash	Main wash phase
③	Bleach	Main wash (Remaining w ashing time: 5 Minutes)
④	Softener	Final rinse phase



■ Auto dosing interface

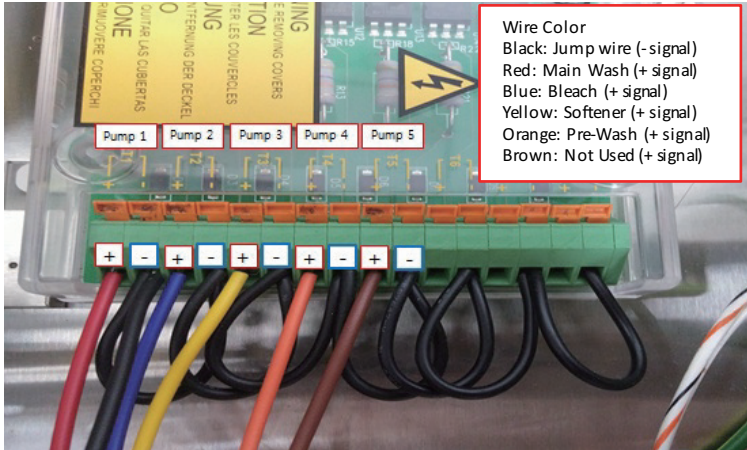

Wire Color
 Black: Jump wire (- signal)
 Red: Main Wash (+ signal)
 Blue: Bleach (+ signal)
 Yellow: Softener (+ signal)
 Orange: Pre-Wash (+ signal)
 Brown: Not Used (+ signal)



Back of Washer

CH	Type	Wire Color	Signal Type
①	Main Wash	Red	+
②	Bleach	Blue	+
③	Softener	Yellow	+
④	Pre-Wash	Orange	+
⑤	-	Brown	+
⑧	-	Black	-

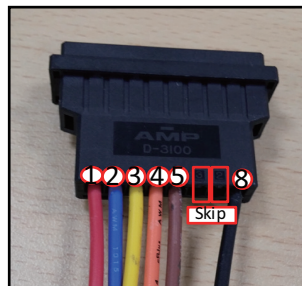

※ Dosing time should be set according to the flow rate of the pump. We recommend not exceeding 30mL for detergent and 50mL for Bleach/Softener. Refer to detergent/chemical instructions to determine the dosing time for optimal performance.

■ INSTALL THE APPLIANCE ON A FLAT AND FIRM SURFACE

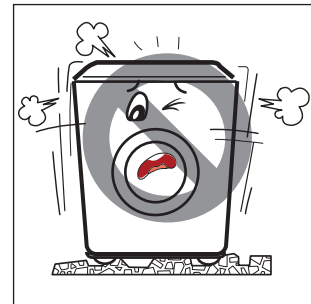
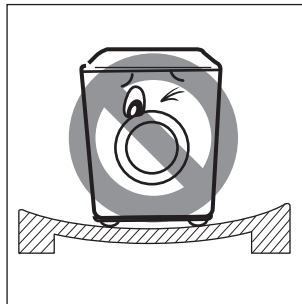
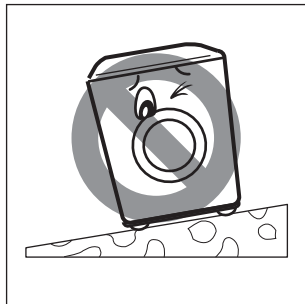
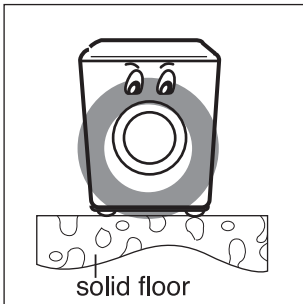

■ Level floor

- Allowable slope under entire washer is 1°.
- **To minimize noise and vibration, the washer MUST be installed on a solidly constructed floor.**
- Carpeting and soft tile surfaces are not recommended.
- Never install the washer on a platform or weakly supported structure.

NOTE: A firm, solid floor is even more critical to a front-loading washer than to a top-loader. If your floor is wood and/or frame construction, you may need to reinforce it. Front-loaders use substantially faster spin speeds than top-loaders, causing greater vibration. If the floor is not solid, your washer will vibrate. You will hear and feel the vibration throughout your house.

■ CONNECT POWER PLUG

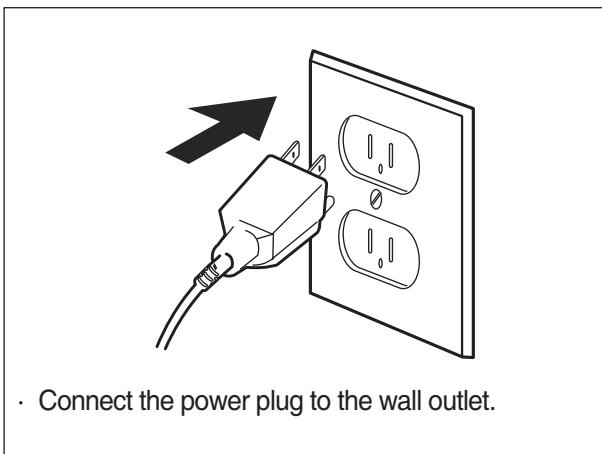

- Connect the power plug to the wall outlet.

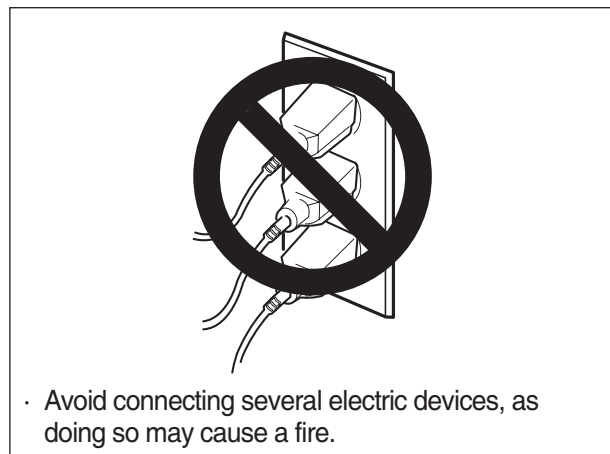

- Avoid connecting several electric devices, as doing so may cause a fire.

- Must be within 60" (1.5 m) of either side of the washer. Do not overload the outlet with more than one appliance.
- Time-delay fuse or circuit breaker is recommended.

NOTE: It is the personal responsibility and obligation of the customer to have a proper outlet installed by a qualified electrician.

■ Level adjustment



- Leveling the washing machine properly prevents excessive noise and vibration. Install the appliance on a solid and level floor surface, preferably in a corner of the room.
- If the floor is uneven, adjust the adjustable feet as required. (Do not insert pieces of wood, etc. under the feet.)

NOTE: Extend the feet no more than necessary to level the washer. The more the feet are extended, the more the washer will vibrate.

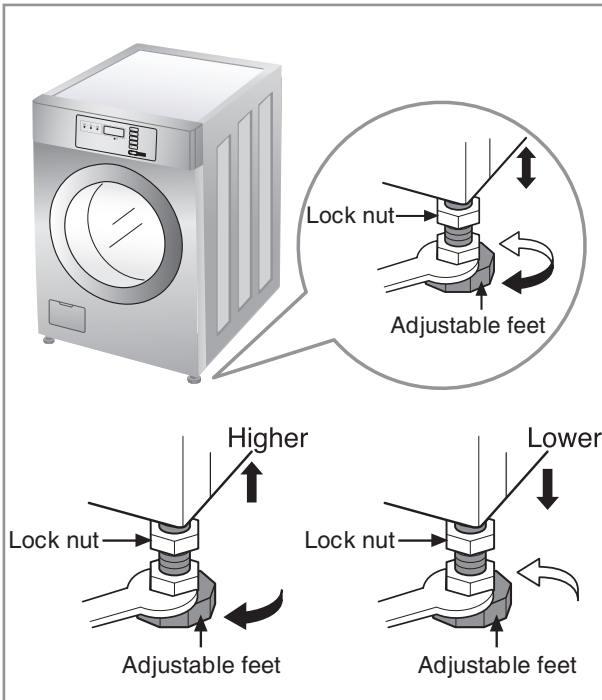

- Make sure that all four feet are stable and resting on the floor and then check that the appliance is perfectly level (Use a level).
- After the washer is level, tighten the lock nuts up against of the base of the washer. All lock nuts must be tightened.
- It is critical to adjust the feet perfectly. This must be done while the washer is spinning with a load. Use the wrench (supplied) to adjust the feet until there is no vibration. Then tighten the lock nuts to prevent further adjustment.

NOTE: If there is vibration and noise during the spin cycle, re-check the leveling of the washer, adjust the feet as required, and tighten the lock nuts securely to prevent changes in adjustment. Run the washer with a test load to make certain your washer is properly leveled. Put an unbalance weight part in the machine. You can check noise and/or vibration on high speed spin rpm through the QC test mode (Refer to page 20). When the machine spins at high speed, verify that it is stable. If not, adjust the feet accordingly.



※ *Diagonal Check*

When pushing down the edges of the washing machine top plate diagonally, the machine should not move up and down at all. (Please, check both directions.)

■ Electrical connection

- Do not use an extension cord or double adapter.
- If the supply cord is damaged, it must be replaced by a qualified person in order to avoid a hazard.
- If the machine will not be used for an extended time, unplug it, shut off the water supply and open the door to provide ventilation.
- Connect the machine to a grounded outlet in accordance with current wiring regulations.
- The appliance must be positioned so that the plug is easily accessible.
- If fuse blows, it can be replaced with FUSE ASSEMBLY (Fusing requirements: Ceramic 250V 12A)

⚠ **WARNING! Concerning the power cord**

Most appliances recommend they be placed upon a dedicated circuit; that is, a single outlet circuit which powers only that appliance and has no additional outlets or branch circuits. Check the specification page of this owner's manual to be certain.

Do not overload wall outlets. Overloaded wall outlets, loose or damaged wall outlets, extension cords, frayed power cords, or damaged or cracked wire insulation are dangerous. Any of these conditions could result in electric shock or fire. Periodically examine the cord of your appliance, and if its appearance indicates damage or deterioration, unplug it, discontinue use of the appliance, and have the cord replaced with an exact replacement part by an authorized servicer.

Protect the power cord from physical or mechanical abuse, such as being twisted, kinked, pinched, closed in a door, or walked upon. Pay particular attention to plugs, wall outlets, and the point where the cord exits the appliance.

■ Connecting the water supply hoses

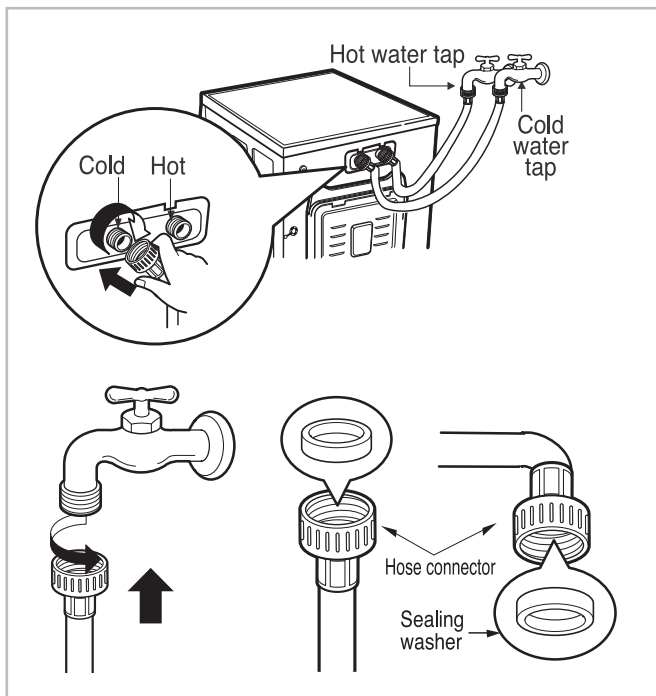

- Water supply pressure must be between 20 psi and 120 psi (138~827kPa).
- Do not crossthread when connecting the inlet hose to the valve.
- If the water supply pressure is more than 120psi, a pressure reducing device should be installed.
- Two sealing washers are supplied with the water inlet hoses to prevent water leaks.
- Check for leakage of washing machine connections by turning the tap completely on.
- Periodically check the condition of the hose and replace the hose if necessary.
- Make sure that there is no kink in the hose and that it is not crushed.
- Be sure that the two water input ports are connected to the correct water faucets. The connector for hot water is colored red; the cold is blue.

NOTE: Use new hoses when installing a washing machine. Replace them periodically. Old hoses should not be used.

Do not install your washing machine in a room where temperatures below freezing may occur. Frozen hoses may burst under pressure. The reliability of the electronic control unit may be impaired at temperatures below the freezing point.

If the appliance is delivered in the winter months and temperatures are below freezing, store the washing machine at room temperature for a few hours before putting it into operation.

■ Installation of drain hose

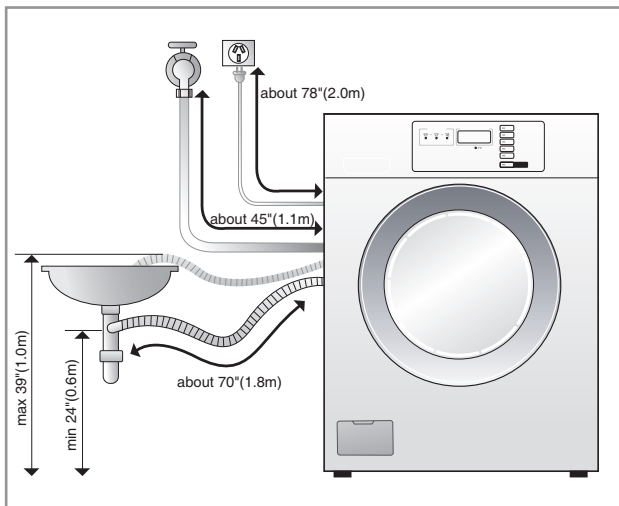

- When installing the drain hose at a sink, secure it so it cannot break away and cause flooding and damage.

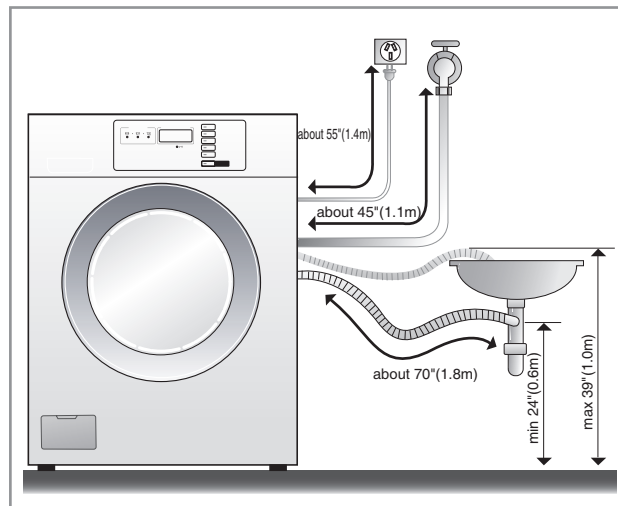

- Properly securing the drain hose will protect the floor from damage due to water leakage.

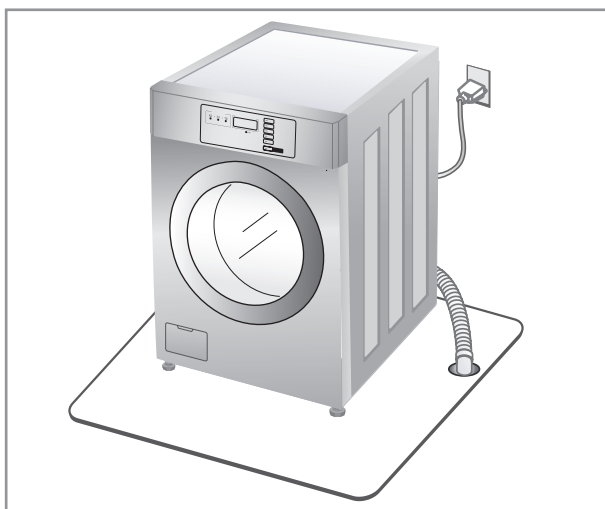

- Place the end of the drain hose in the hole of the floor drain system.

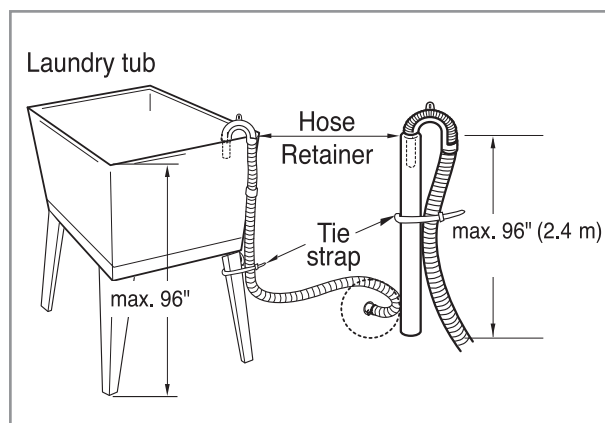

- The drain hose should not be placed higher than 96 in. from the bottom of the washer.
- Properly securing the drain hose will protect the floor from damage due to water leakage.

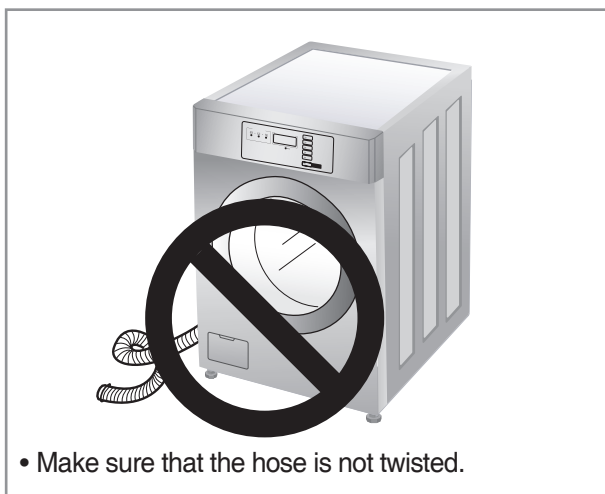

- Make sure that the hose is not twisted.

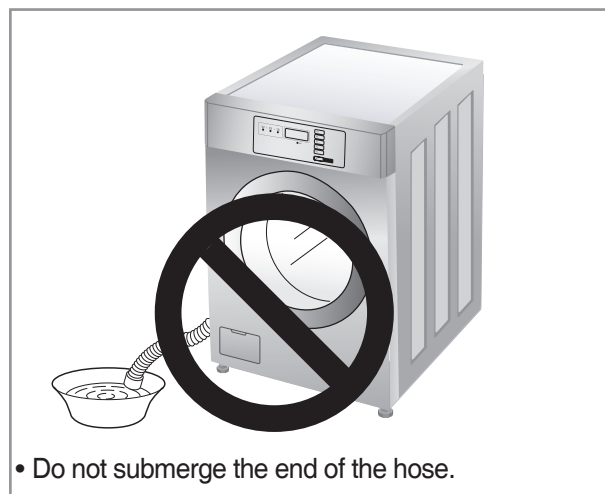

- Do not submerge the end of the hose.

6. OPERATION

CONTROL PANEL FEATURES

Coin type (GCWM1069QS7)

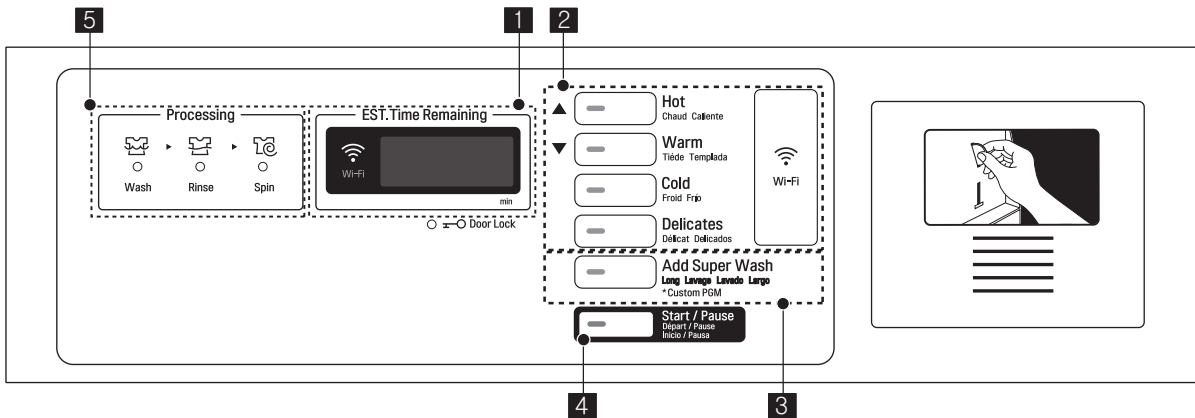

Coin type (GCWM1069QD7)

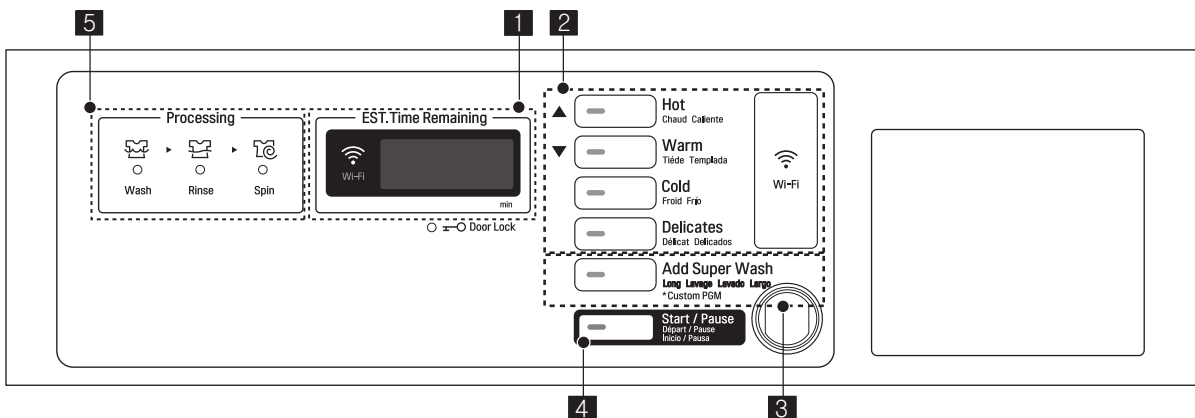

Card / OPL Type (GCWM1069CS7/GCWM1069CD7)

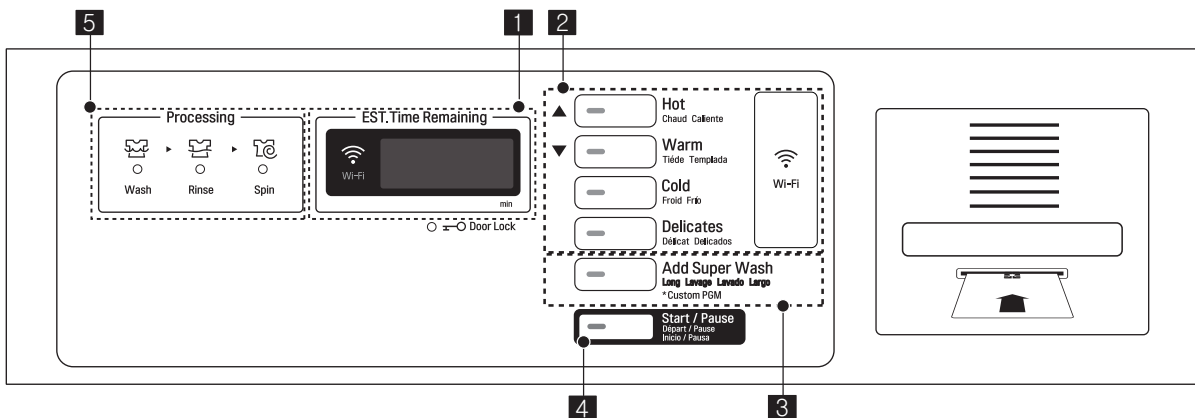

1. Display LED
2. Cycle button
3. Optional function button

4. Start/Pause button
5. Status LED

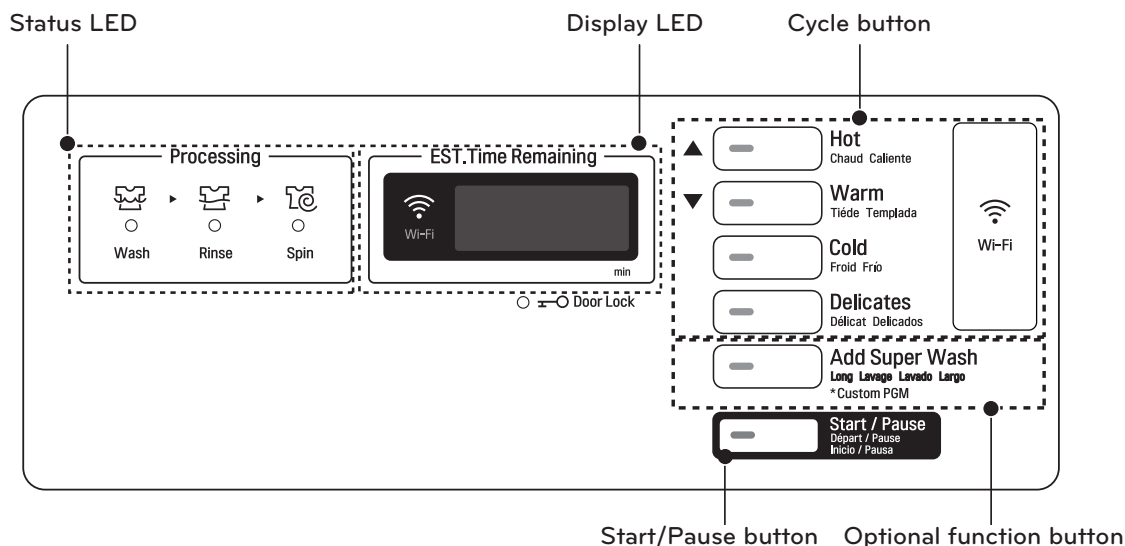

Display LED

The display shows the vend price and remaining time and programming options. Error codes are also displayed here.



Cycle button

Press the CYCLE button to select the desired cycle based on laundry types and conditions.

Hot

Use for hot washing for heavy fabrics, such as white clothes, table linens, and heavily soiled clothes.

Warm

Use for warm washing for heavy fabrics, such as jeans, corduroys, or work clothes.

Cold

Use for cold washing for sturdy fabrics, such as casual work.

Delicates

Use for cold washing for synthetic fabrics, such as washable knit fabric and no-iron finishes.

Normal Cycle (Energy Cycle)

Press and hold the cycle buttons (Hot/Warm/Cold) for 3 seconds to run the Normal cycle. Use the Normal cycle for normally soiled cotton clothing only. Do not use for delicate fabrics such as wool or silk.

Optional function button





Add Super Wash: Wash time or rinse cycle can be added when additional coin is inserted or a valid cash card is entered.

Custom PGM: Customized cycle program can be used. Only available in OPL type.

Start/Pause button

The Start/Pause LED flashes when the full vend price has been satisfied and the cycle has been chosen.

Status LED

LED	Description
 Wash	LED flashes whenever the Washing cycle is in operation.
 Rinse	LED flashes whenever the Rinsing cycle is in operation.
 Spin	LED flashes whenever the Spinning cycle is in operation.
 Door Lock	LED flashes whenever the door lock is activated.
 Wi-Fi	LED flashes when the Wi-Fi is connecting. LED stays lit when the Wi-Fi is connected

■ **Select cycles designed for different types of fabric and soil levels**

CYCLE	Fabric Type	Wash / Rinse Temp.
Hot	Cotton, Linon, Towels, Shirts, Sheets	Hot/Cold
Warm	Mixed Loads, Work Clothes, Jeans, Shirts	Warm/Cold
Cold	Dress Shirts/Pants, Wrinkle Free Clothing, Poly/Cotton Blend Clothing, Tablecloths.	Cold/Cold
Delicates	Dress Shirts/Blouses, Nylons, Sheer or Lacy Garment	Cold/Cold

Add super wash

- Adds an additional 3 minutes of washing time and an extra rinse.

Custom PGM

- Customized cycle program can be used. Only available in OPL type.

7. WIRING DIAGRAM/PROGRAM CHART/PCB LAYOUT

■ Wiring Diagram

Single type :GCWM1069CS7
GCWM1069QS7

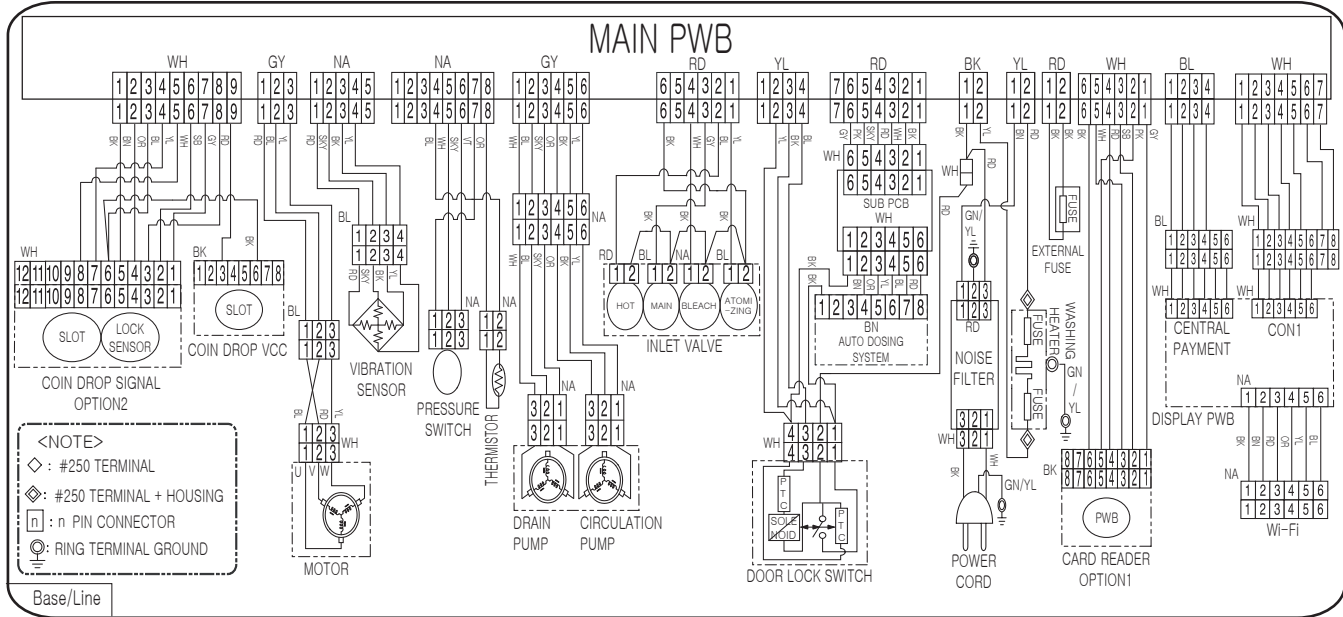

Stack type :GCWM1069CD7
GCWM1069QD7

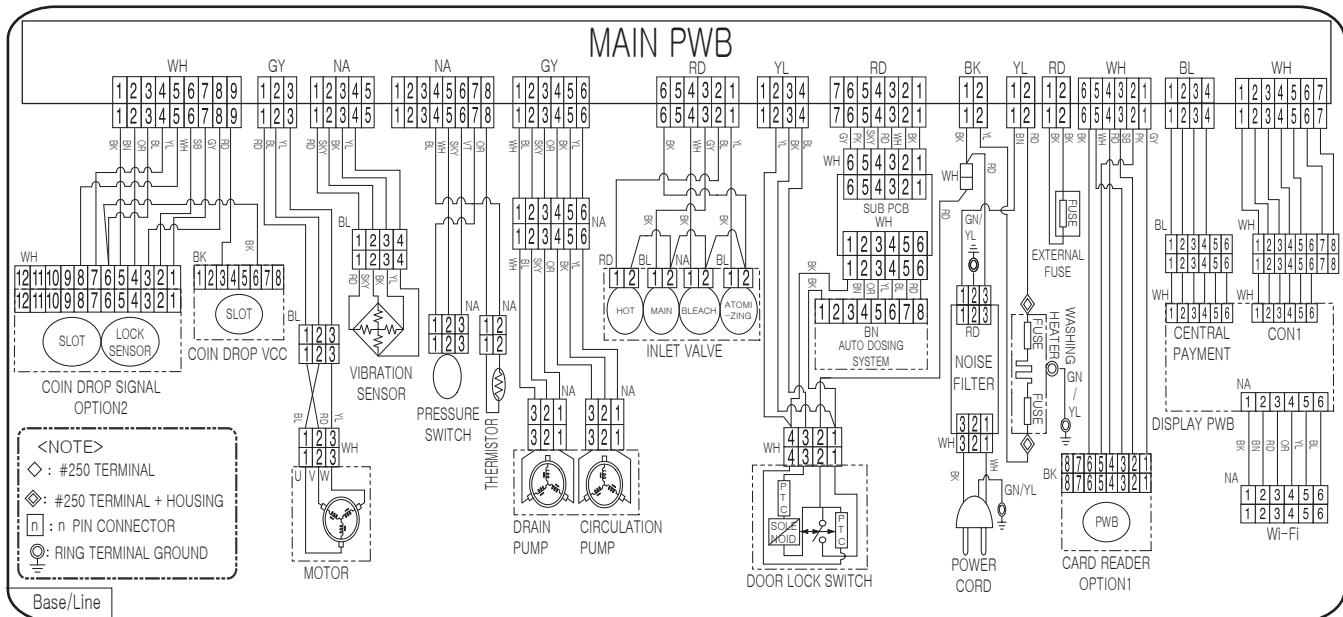

Program Chart

Course	PREWASH (A+B+C)			WASH (D+E)			RINSE ((G+H+J+K+L)*n)						SPIN (M+N+O+P)						Default Working Time					
	(A) Water Supply	(B) Tumble	(C) Drain	(D) Water Supply	(E) Tumble (CCCC - D + Super Wash)		(G) Drain	(H) Intermittent Spin	(I) Spin		(J) Wave Force	(K) Water Supply	(L) Tumble (t-G-H-J)	(M) Drain	(N) Intermittent Spin	(O) Spin						(P) Disentangle		
					CCCC	Super Wash			Non-stop Wash				Rt			ISSd								
				(High, Middle / Low)	S-15 (High, Middle / Low)	SPT: Uut /both			X	O		(High, Middle / Low)	S-16 (High, Middle / Low)			0	1	2		3	4	5	6	
Hot	1	2-4	1	3 / 2	2-12 / 3-13	+3	1	3	0	1	1	3 / 2	1-9 / 2-10	1	3	6	6	6	6	6	6	6	1	Wash (8) Rinse (17) Spin (11) Total (36)
Warm									0	0						6	6	6	6	6	6	3		
Cold									0	0						6	6	6	6	6	6			
Delicate									0	0						6	6	6	6	6	6			
Tub Clean	-	-	-	60	-	-	-	-	0	0	3	5	99											

■ PCB Layout (Main)

P/N : EBR86778404

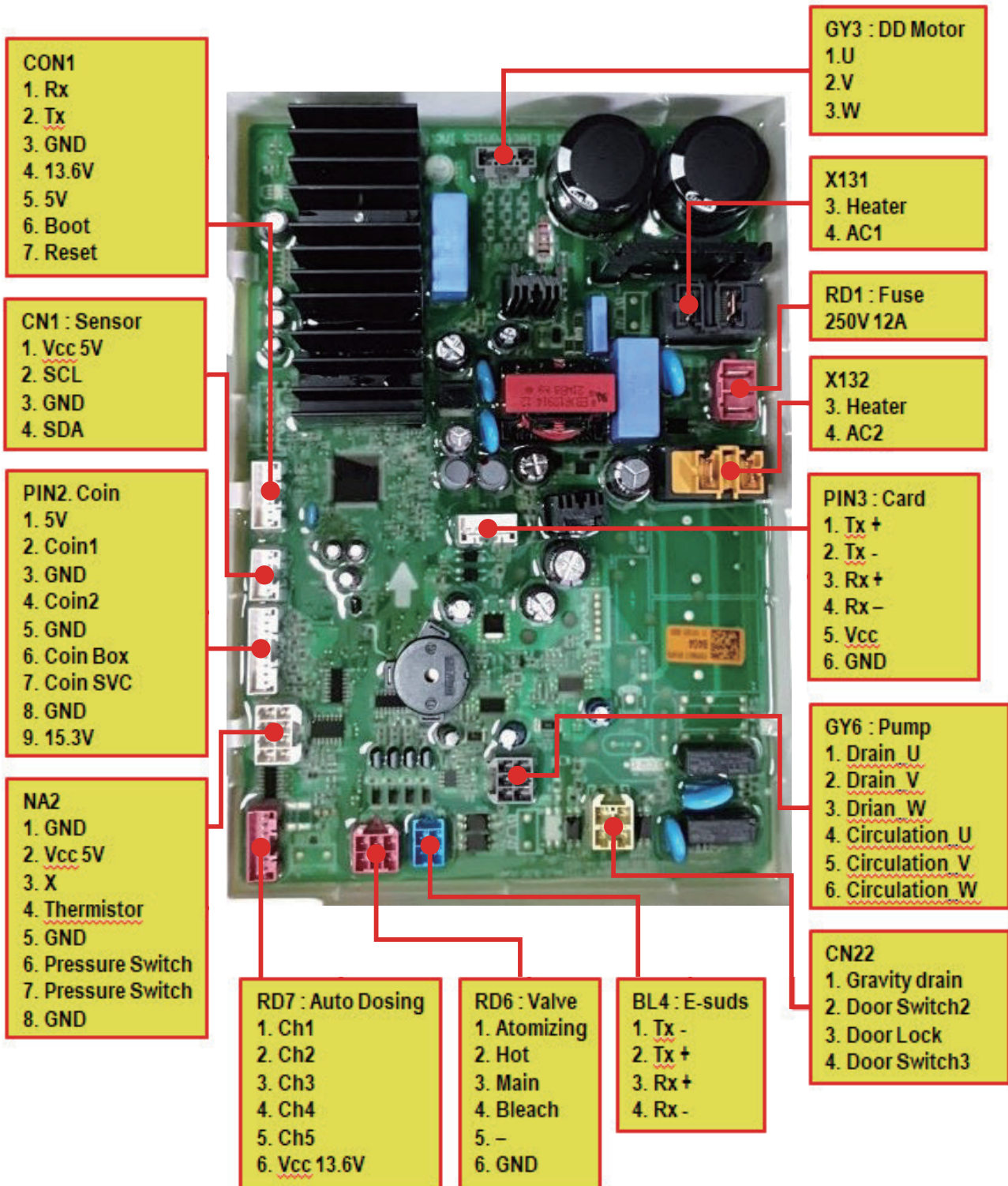

8. TROUBLESHOOTING

8-1. BEFORE PERFORMING SERVICE

- Be careful of electric shock when disconnecting parts while troubleshooting.
- The voltage of each terminal is 120V- when the unit is plugged in.

8-2. QC TEST MODE.

The washer must be empty.

How to enter Programming mode:

- Coin type – Turn on/off toggle switch.
- Card type – Insert the service card.
- All types –

- 1) Press the 1st & 3rd button at the same time.
- 2) Press the 2nd & 3rd buttons to toggle numbers.

Then, press the 4th button to move to the next digit.

- 3) Press the Start button to finish password input.

※ Default Password : 3000

<Control Panel Button>

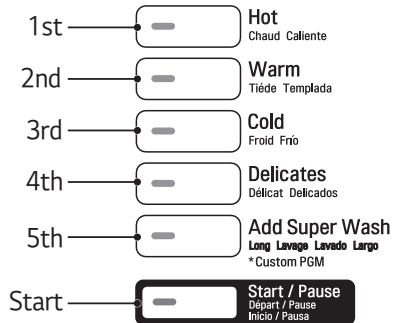

Number of times the Start button is pressed	Check point	Display
0	Enter SVC mode	
1	Turns on all lamps and locks the door	Displays
2	Tumble clockwise	rpm (40-50)
3	Low speed spin	rpm (600)
4	High speed spin	rpm (1200)
5	Inlet valve for main water turns on	Water level frequency (255-)
6	Inlet valve for hot water turns on	Water level frequency (255-)
7	Inlet valve for atomizing turns on (Single model) Inlet valve for softener turns on (Stack model)	Water level frequency (255-)
8	Inlet valve for bleach turns on (Single model) Inlet valve for atomizing/bleach turns on (Stack model)	Water level frequency (255-)
9	Tumble counter clockwise	rpm (40-50)
10	Heater turns on	Displays water temperature
11	Circulation pump turns on	Water level frequency (255-)
12	Drain pump turns on	Water level frequency (255-)
13	All lamps turn on	Displays , 1U:XX, 1g:XX, 12:XX, 1C:XX alternately (Version)
14	Button check	
15	High speed spin	rpm (1200)
16	PDA signal check	this function is not applied in this machine
17		

8-3. HOW TO CHECK THE WATER LEVEL FREQUENCY

- Press and hold the ADD SUPER WASH+Delicate and WARM buttons simultaneously.



When you check the water level, the first digit is a 0 which means 2.

A display indicating 041 is a water level frequency of 241 multiplied by 0.1 KHz , for an actual frequency of 241 KHz.

8-4. HOW TO CHECK THE RPM

- Press the ADD SUPER WASH AND HOT button simultaneously.

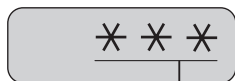









Under 200 rpm: The display indicates the rpm. (Under 200 rpm)









Over 200 rpm: The display indicates the rpm. (x 10 rpm)

- So, for example a display indicating 050 : rpm of 050 x 10 rpm = 500rpm

8-5. ERROR DISPLAY

- If you press the START button when an error is displayed, any error except *PE* will disappear and the machine will go into the pause status.

	ERROR	SYMPTOM	CAUSE
1	WATER INLET ERROR		<ul style="list-style-type: none"> • Correct water level (246) is not reached within 10 minutes after water is supplied or it does not reach the preset water level within 12 minutes.
2	IMBALANCE ERROR		<ul style="list-style-type: none"> • The load is too small. • The appliance is tilted. • Laundry is gathered to one side. • Non distributable things are put into the drum.
3	DRAIN ERROR		<ul style="list-style-type: none"> • Not fully drained within 3 minutes.
4	OVER FLOW ERROR		<ul style="list-style-type: none"> • Water is overflowing (water level frequency is over 213). ※ If  is displayed, the drain pump will operate to drain the water automatically.
5	PRESSURE SENSOR ERROR		<ul style="list-style-type: none"> • The SENSOR SWITCH ASSEMBLY is out of order.
6	DOOR OPEN ERROR		<ul style="list-style-type: none"> • Is the door opened or not completely closed?
			<ul style="list-style-type: none"> • Door lock is broken.

	ERROR	SYMPTOM	CAUSE
7	LOCKED MOTOR ERROR		<ul style="list-style-type: none"> • The connector (3-pin, male, blue) in the MOTOR HARNESS is not connected to the connector (3-pin, female, white) of STATOR ASSEMBLY. • The electric contact between the MOTOR HARNESS and the MAIN PWB ASSEMBLY is bad or unstable. • The MOTOR HARNESS between the STATOR ASSEMBLY and MAIN PWB ASSEMBLY is cut (open circuit).
8	EEPROM ERROR		<ul style="list-style-type: none"> • EEPROM is out of order. ※ Displayed only when the START button is first pressed in the QC Test Mode.
9	CARD READER ERROR		<ul style="list-style-type: none"> • Disconnection of Card Reader Wire.
10	Thermistor ERROR		<ul style="list-style-type: none"> • Thermistor is opened or shorted.
11	VIBRATION SENSOR ERROR		<ul style="list-style-type: none"> • Vibration sensor is disconnected or broken.
12			<ul style="list-style-type: none"> • Load is out of balance or vibration sensor is broken.
13	Wi-Fi ERROR		<ul style="list-style-type: none"> • Wi-Fi module is disconnected or broken.
14			<ul style="list-style-type: none"> • No Wi-Fi signal or is not registered with machine.

8-6. DISPENSER

The dispenser drawer is a multi-chambered reservoir that allows the user to add all the appropriate laundry additives before starting the cycle. It has a place for pre-wash and Main wash detergent, fabric softener, and bleach. Powdered or liquid detergents may be used, but softener and bleach must be liquids.

Detergents should carry the HE designation. Do not use regular detergents in the washer or overusing will occur. Regular detergents also cause a scum build-up in the tub, which leads to poor performance and a foul odor.

-Single model-

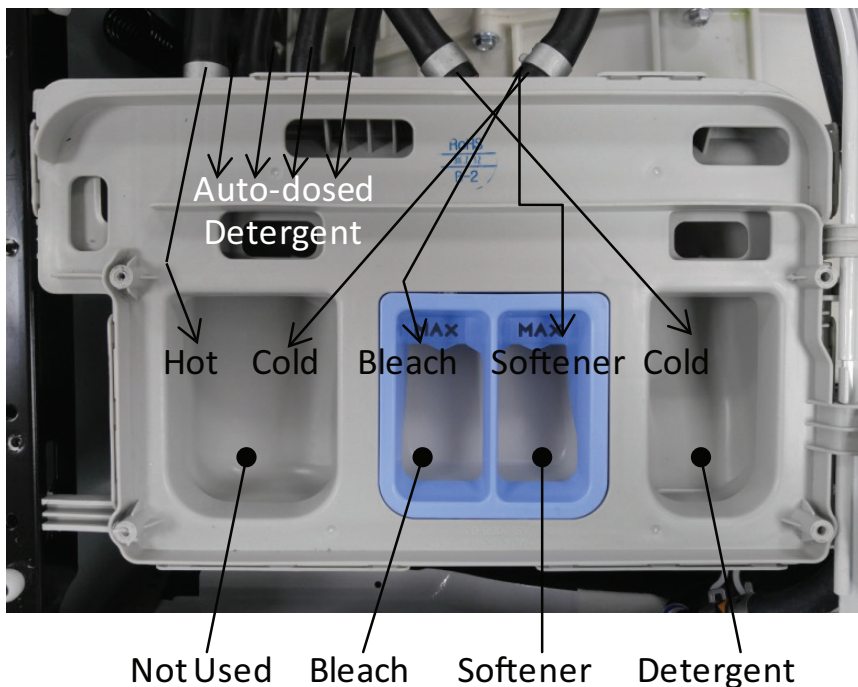

-Stack model-

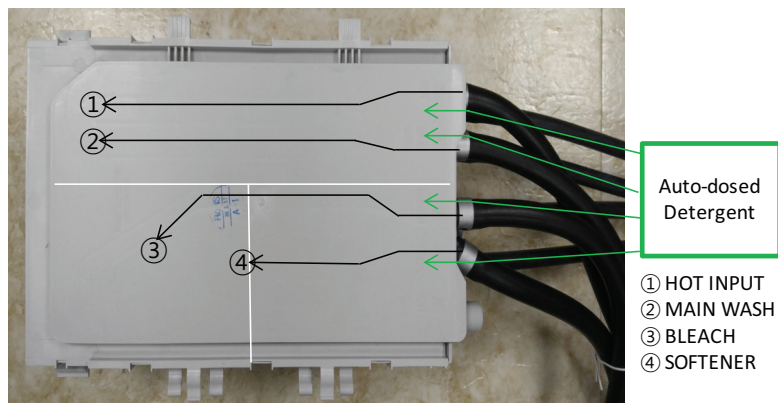

9. DIAGNOSIS AND TROUBLESHOOTING

⚠ WARNING

1. Be careful of electric shock if disconnecting parts while troubleshooting.
2. First, check the connection of each electrical terminal with the wiring diagram.
3. If you replace the MAIN PWB ASSEMBLY, reinsert the connectors correctly.

NO POWER

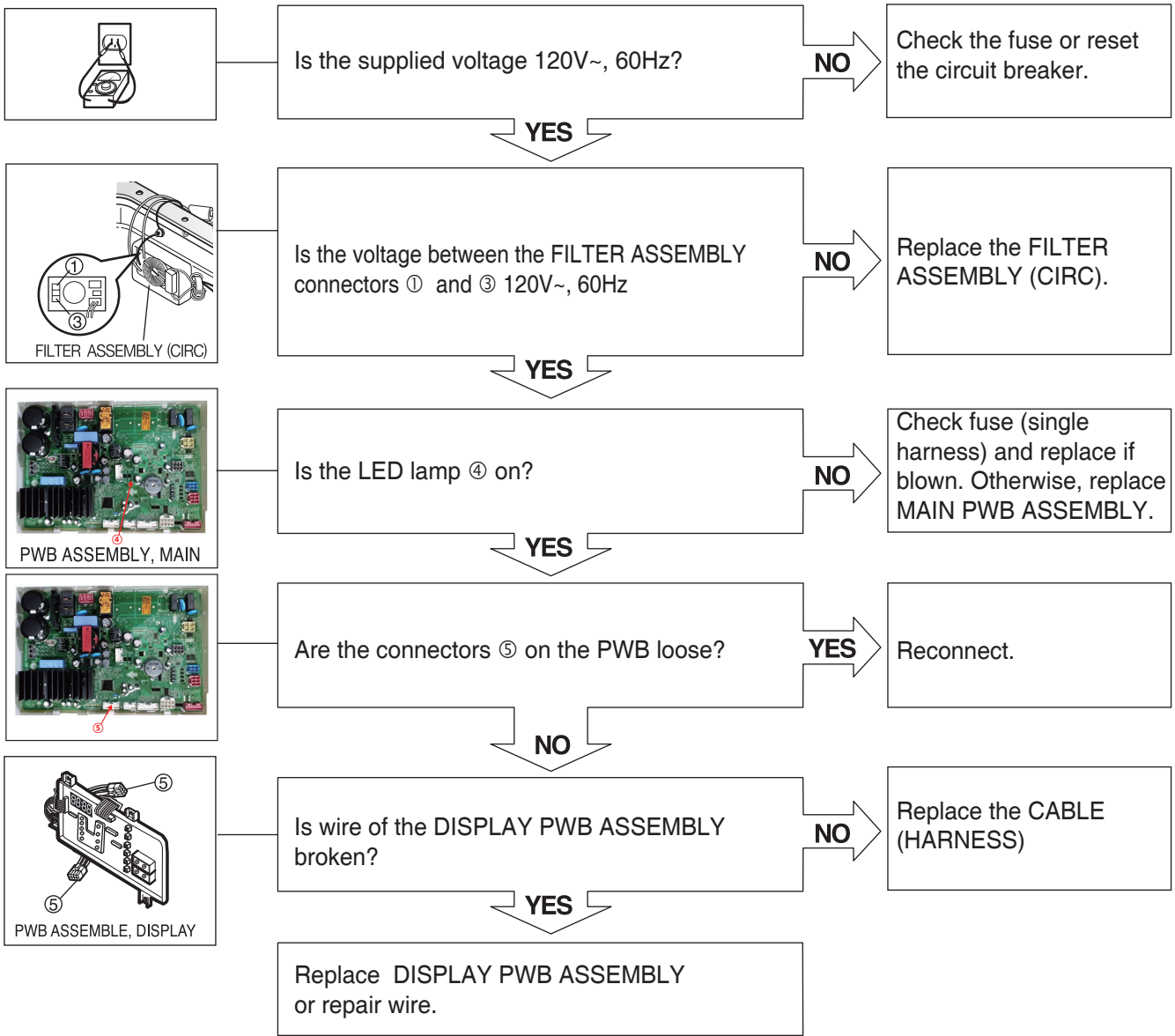

Symptom	Check Point
1. NO POWER	1.Check Electric Wiring. 2.Check the customer's outlet. 3.Check Noise Filter. 4.Check LED on in Main PWB 5.Check External Fuse (Single Harness).

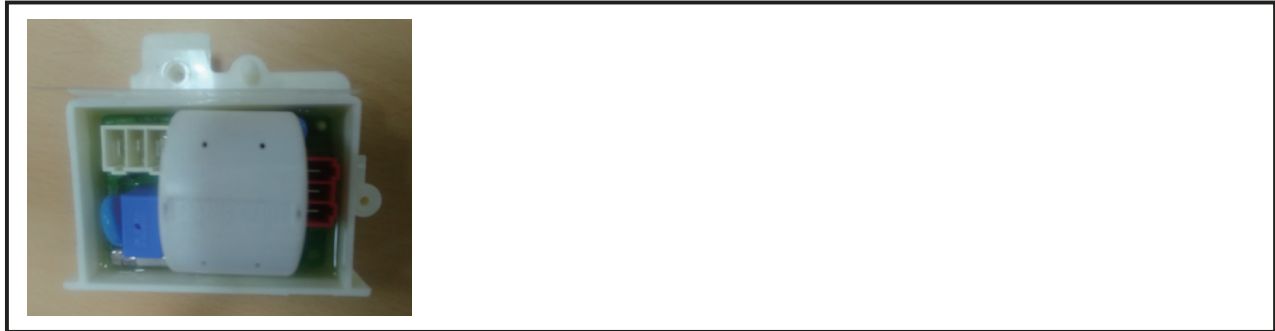

Circuit in the MAIN PWB / Wiring Diagram

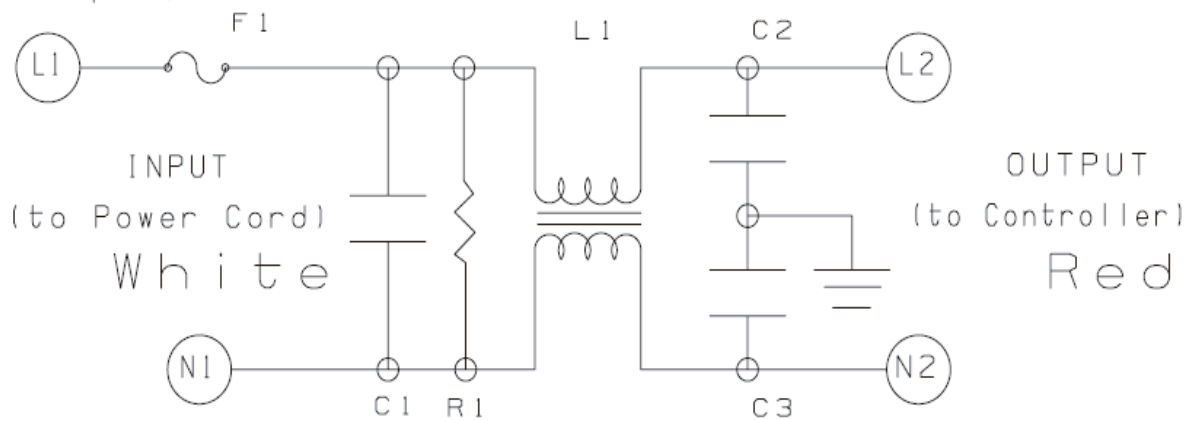

IE ERROR (NO WATER SUPPLY)

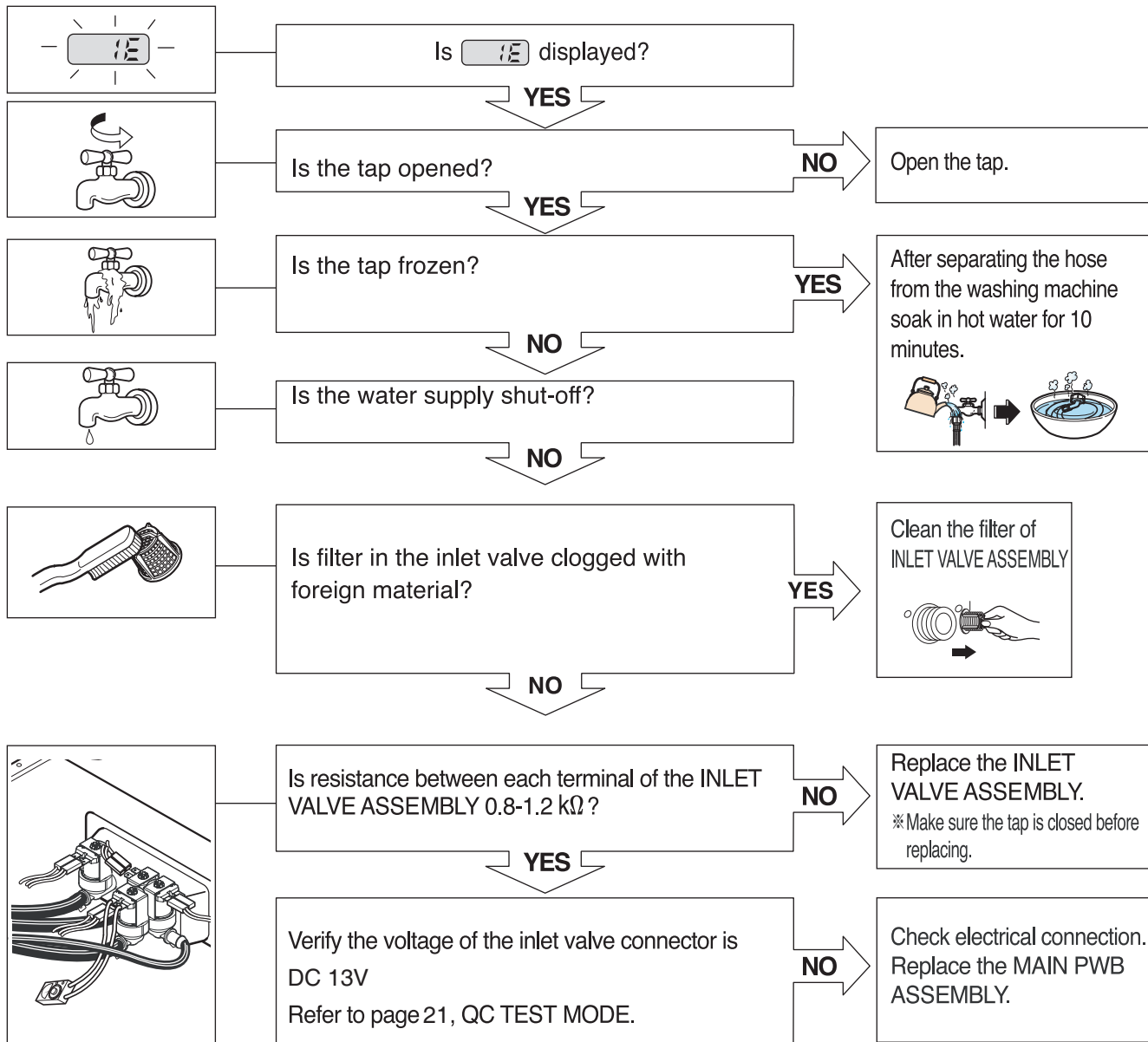

Symptom	Check Point
1. INLET VALVE ERROR	1. Check Electric Wiring. 2. Check Inlet valve's Resistance. 3. Check Inlet valve clogged. 4. Voltage of the inlet valve's connector. -. Valve running : 13~15Vdc

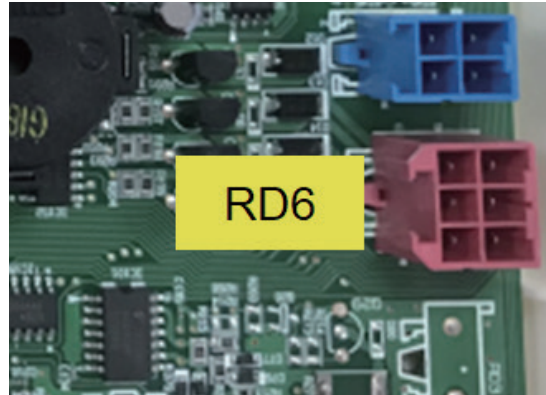
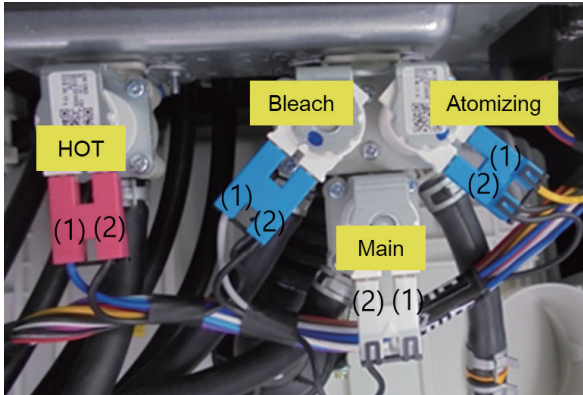

Circuit in the MAIN PWB / Wiring Diagram

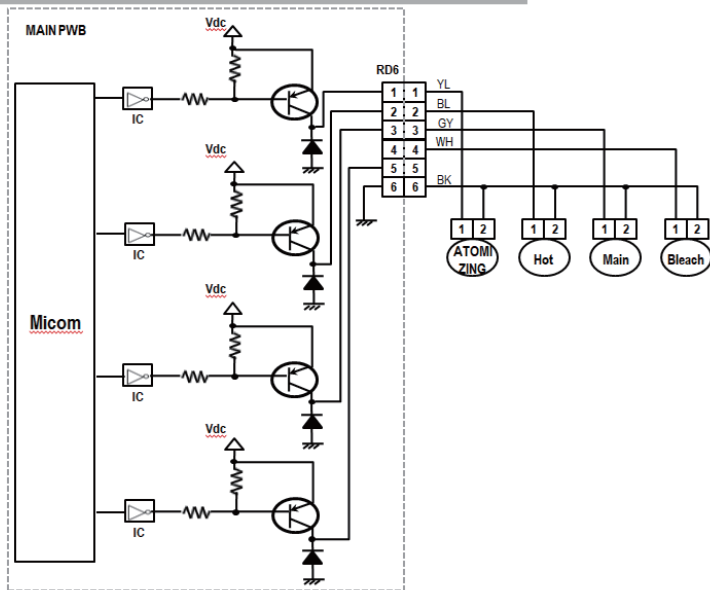

Inlet Valve	Main PWB	Resistance [k Ω]
Hot (1) ~ (2)	RD6 2 nd ~ RD6 6 th	0.8 ~ 1.2
Main (1) ~ (2)	RD6 3 rd ~ RD6 6 th	0.8 ~ 1.2
Bleach (1) ~ (2)	RD6 4 th ~ RD6 6 th	0.8 ~ 1.2
Atomizing (1) ~ (2)	RD6 1 st ~ RD6 6 th	0.8 ~ 1.2

OE ERROR (DRAIN TROUBLE)

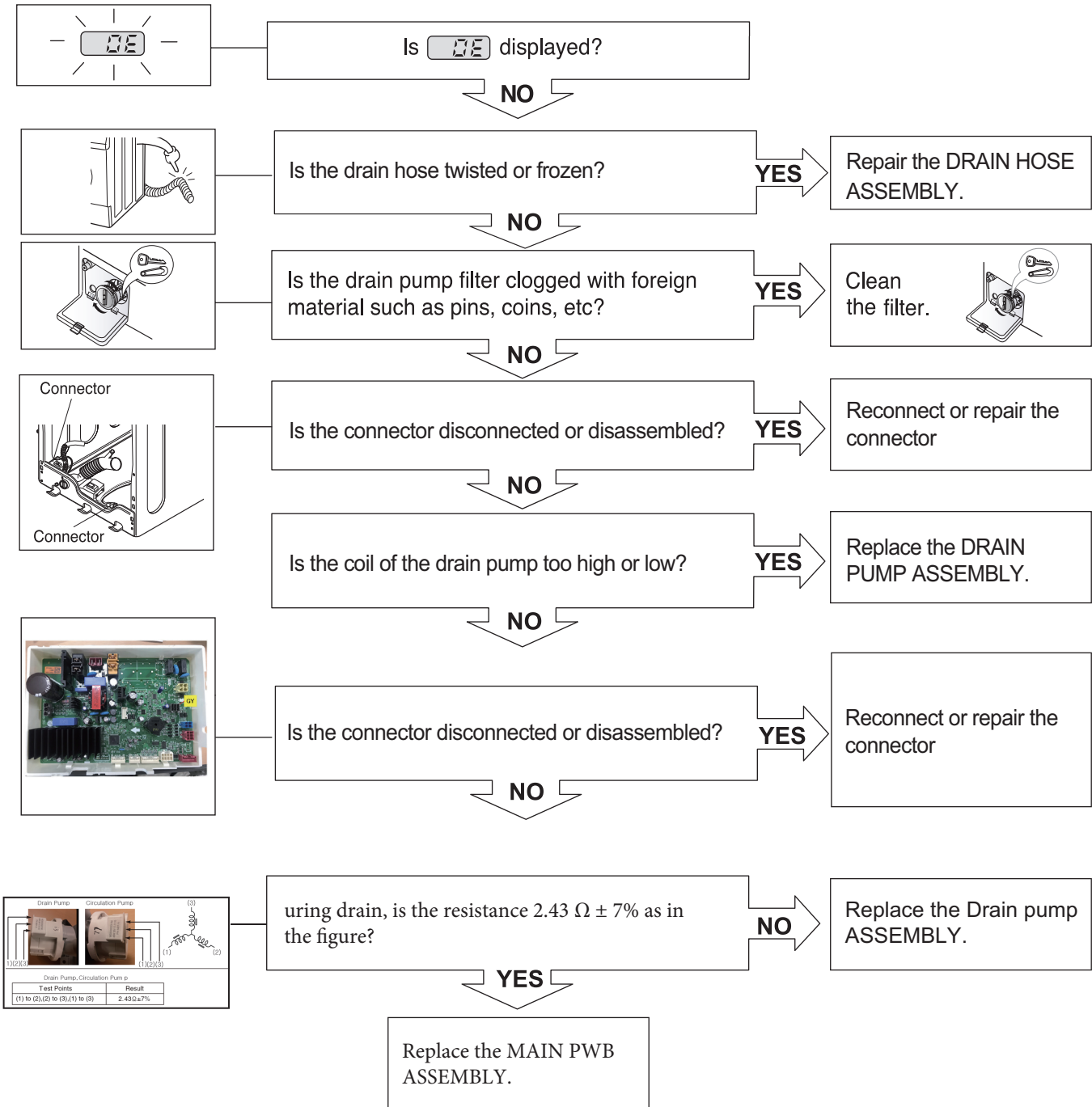

Symptom	Check Point
1. Drain Error (OE)	1.Check Electric Wiring. 2.Check drain pump Resistance. 3.Check drain line clogged.

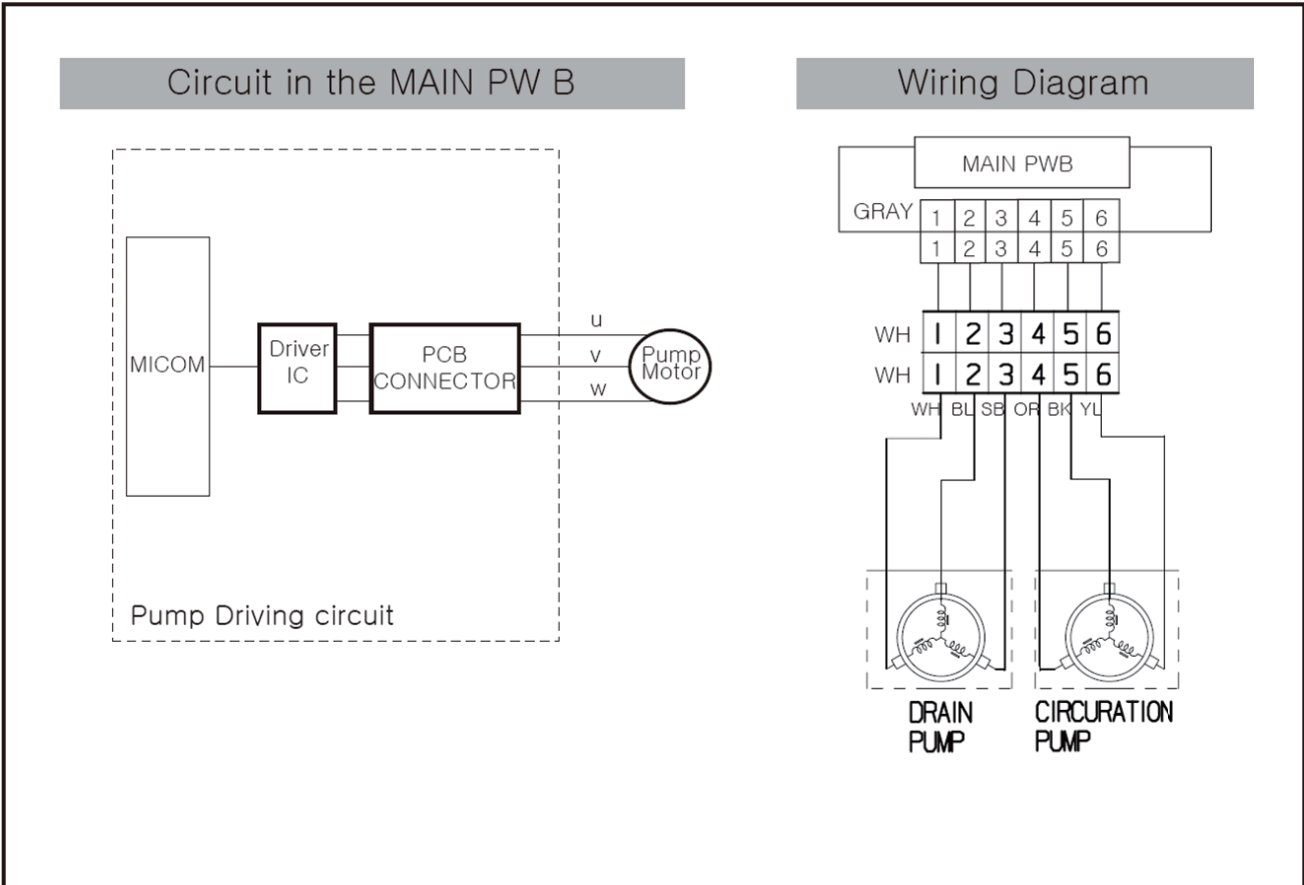
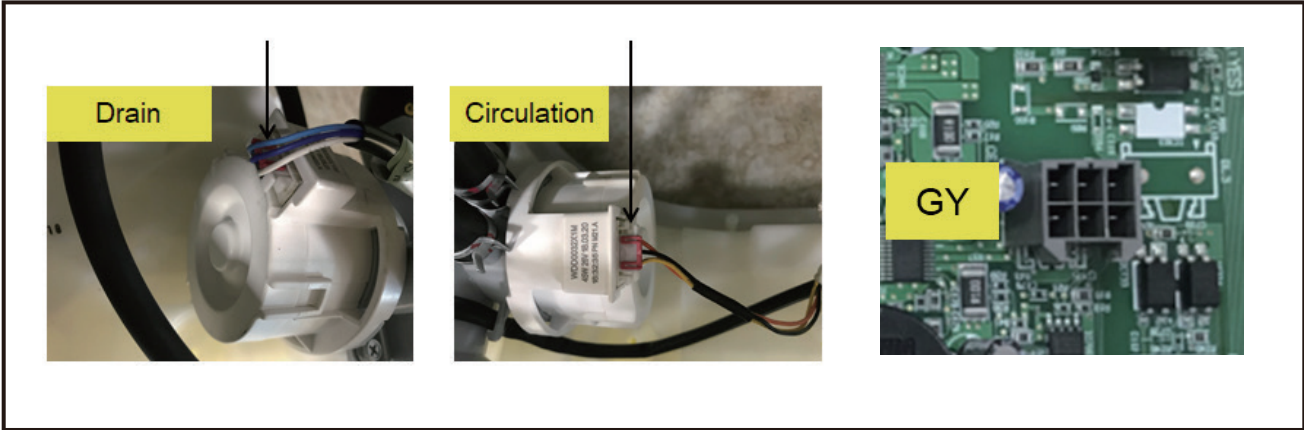

FE ERROR

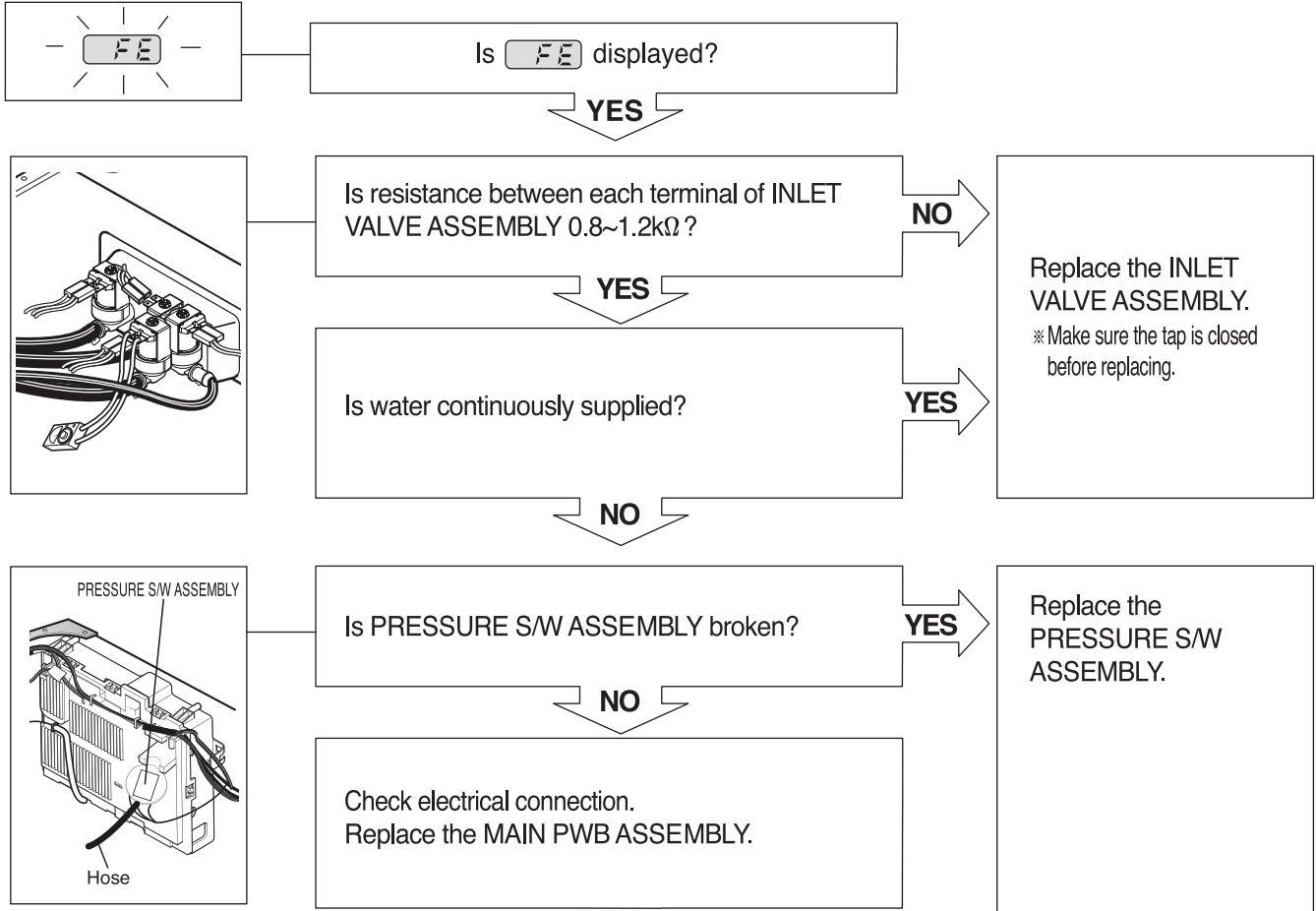

PE ERROR (PRESSURE S/W TROUBLE)

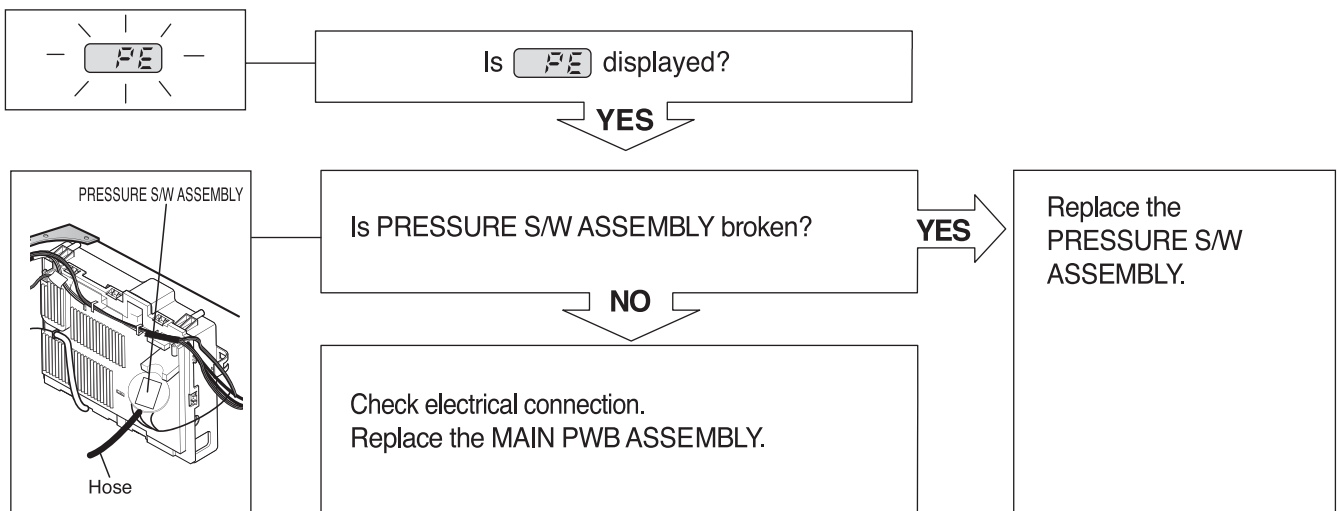

Symptom	Check Point
1. PRESSURE SENSOR ERROR (PE)	1.Check Electric Wiring. 2.Check Pressure sensor's Resistance. 3.Check Air chamber and Tube clogged.

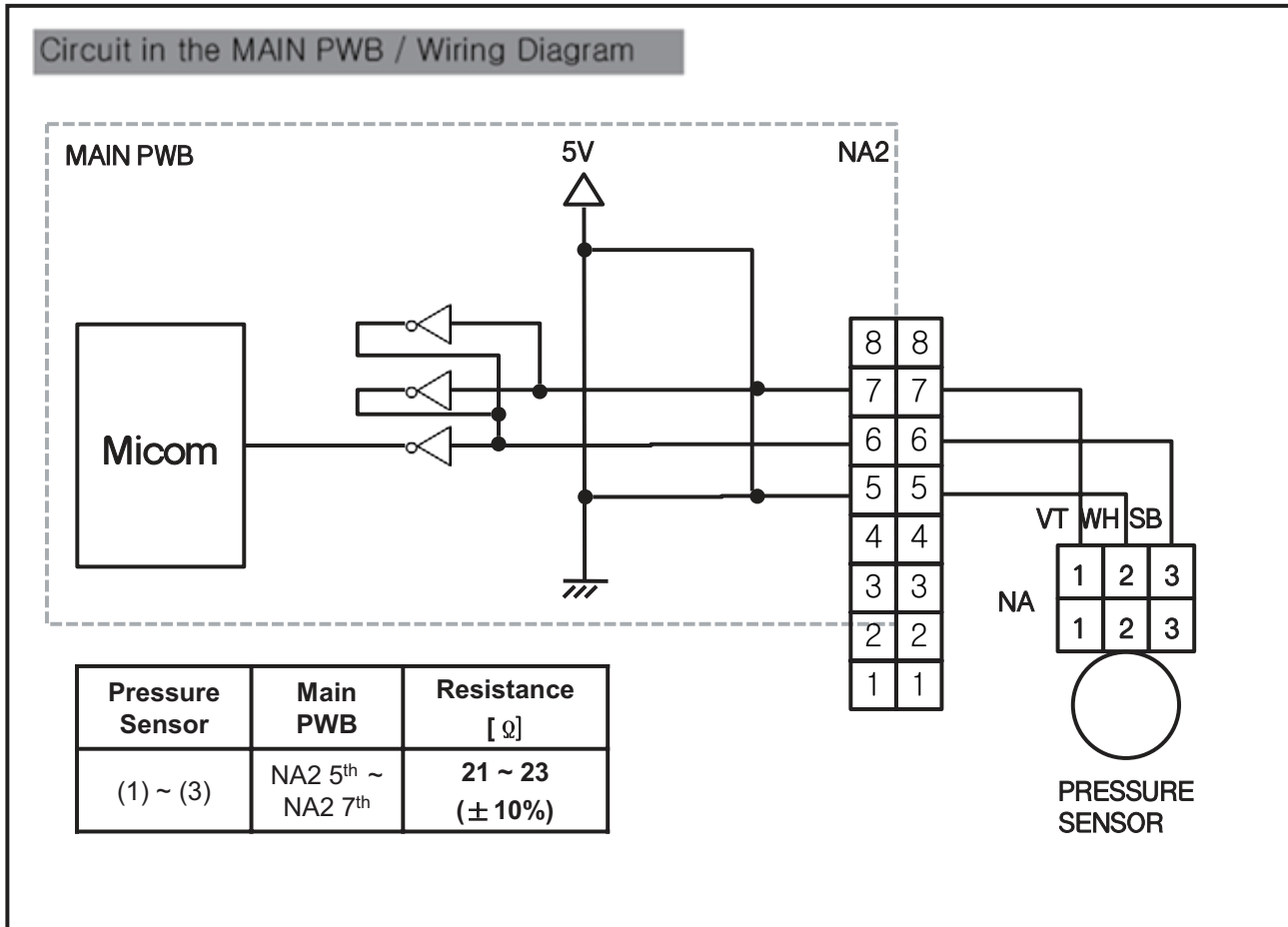
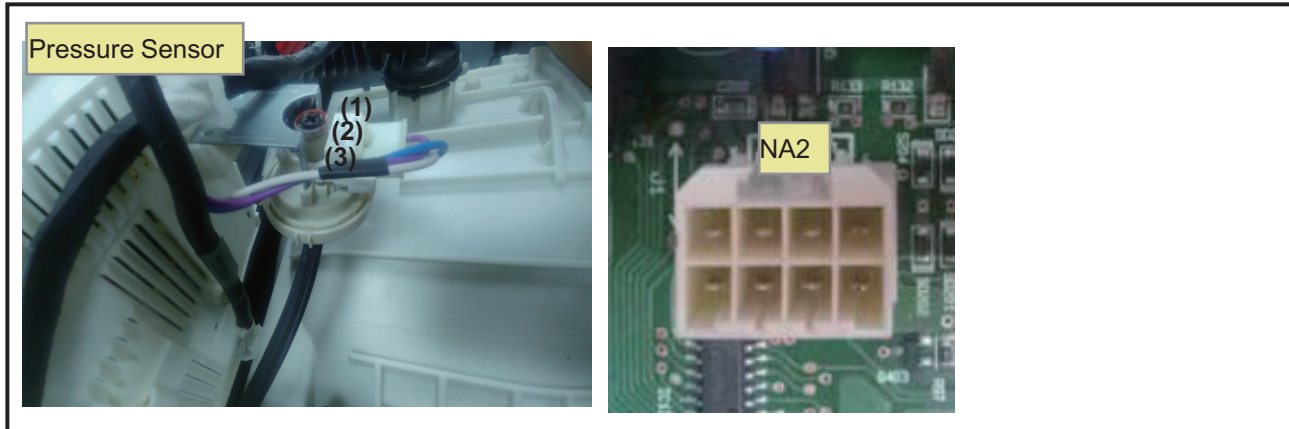

dE1/dE2 ERROR (DOOR ERROR)

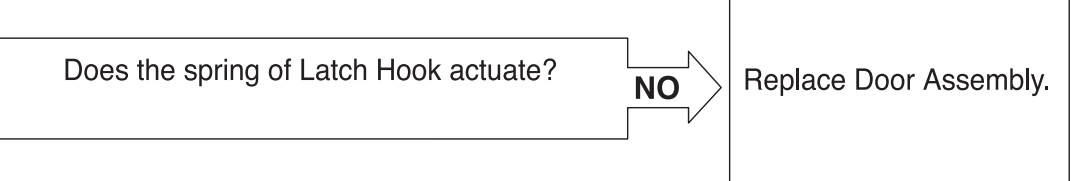
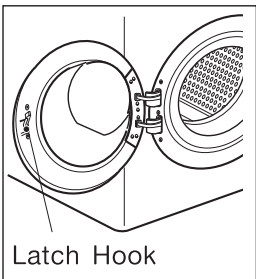
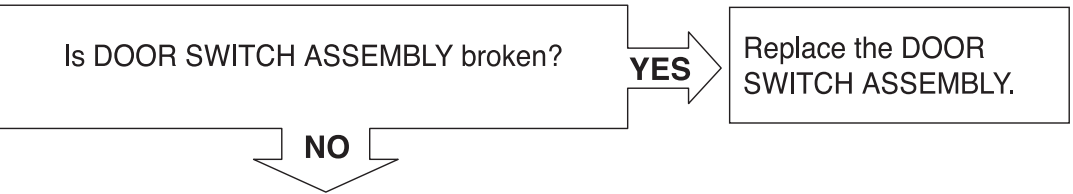
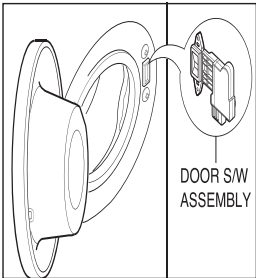
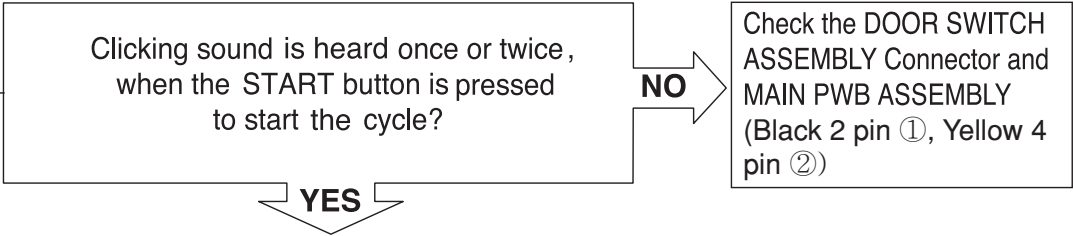
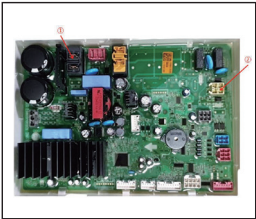
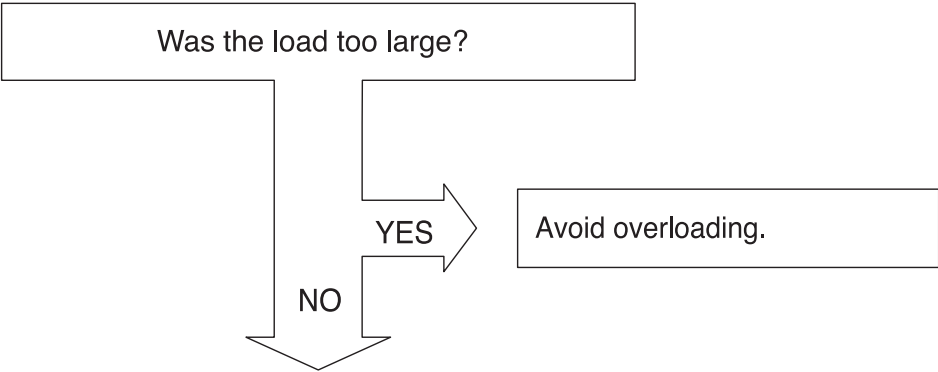
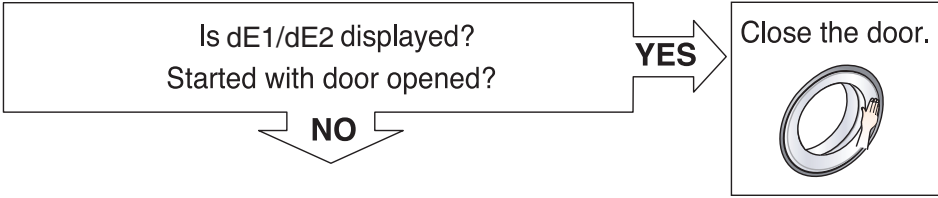

Symptom	Check Point
1. DOOR OPEN ERROR (dE)	1.Check Electric Wiring. 2.Check latch hook spring. (Cracked) 3.Check Door switch's Resistance. 4.Check Voltage of Door switch's connector.

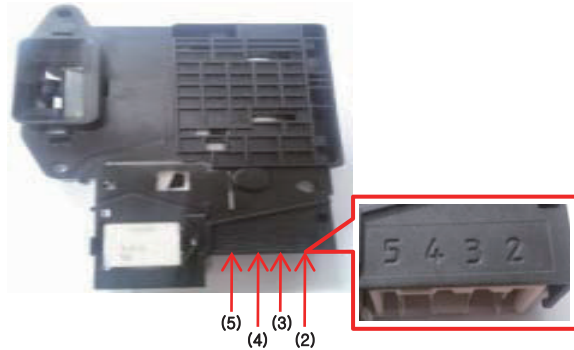

Circuit in the MAIN PWB / Wiring Diagram

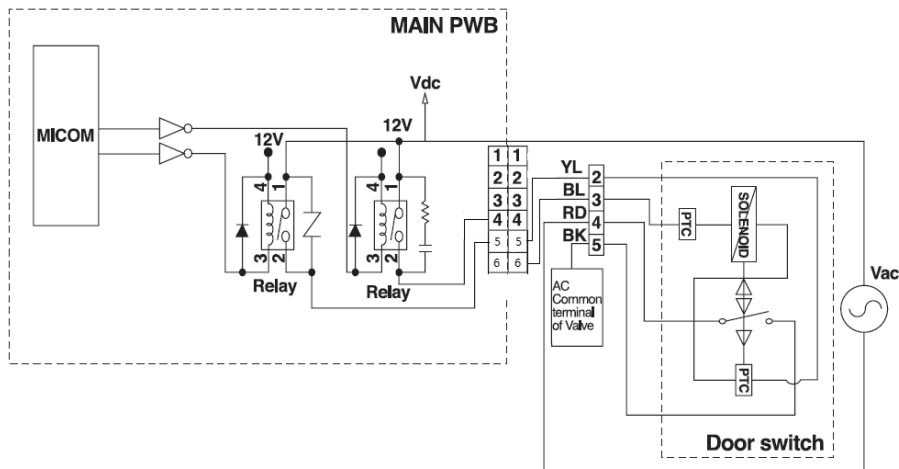

Door switch (Type1)	Result	Remarks
(2) ~ (4)	700~1500Ω	At 77°F (25°C)
(3) ~ (4)	65~85Ω	At 77°F (25°C)
(4) ~ (5)	Infinity	
(2) ~ (4)	120 Vac	Voltage Input

Door switch (Type2)	Result	Remarks
(2) ~ (4)	700~1500Ω	At 77°F (25°C)
(3) ~ (4)	90~120Ω	At 77°F (25°C) With Latch
	Infinity	Without Latch
(4) ~ (5)	Infinity	
(2) ~ (4)	120 Vac	Voltage Input

VIBRATION & NOISE IN SPIN

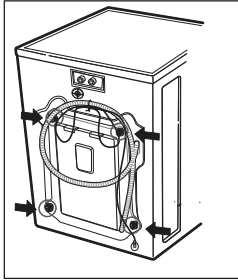

Have all the transit bolts and base packing been removed?

NO

Remove the transit bolts and Base packing.

YES

Is the washer installed on a solidly constructed floor?

NO

Move the washer or reinforce the floor.

YES



Base Packing

Check if the washer is perfectly level as follows:

Level



Check the leveling of the washer with a level and check that the washer is stable.

Put an unbalance part (rubber) inside of drum and start QC test mode and run in high spin

When the machine is spinning in high speed, verify that it is stable.

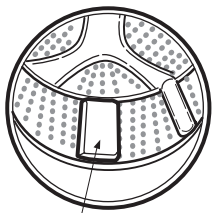

Unbalance Part

If you do not have the unbalance part, put 4.5 to 6.5 lbs (2 to 3 kg) of clothing.

When the machine is spinning at high speed, verify that it is stable.

YES

If it is not stable, adjust feet accordingly. After the washer is level, tighten the lock nuts up against of the base of the washer. All lock nuts must be tightened.

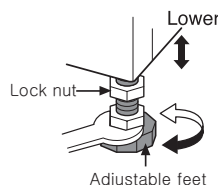
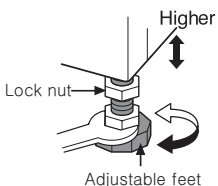

DETERGENT/SOFTENER/BLEACH DOES NOT FLOW IN

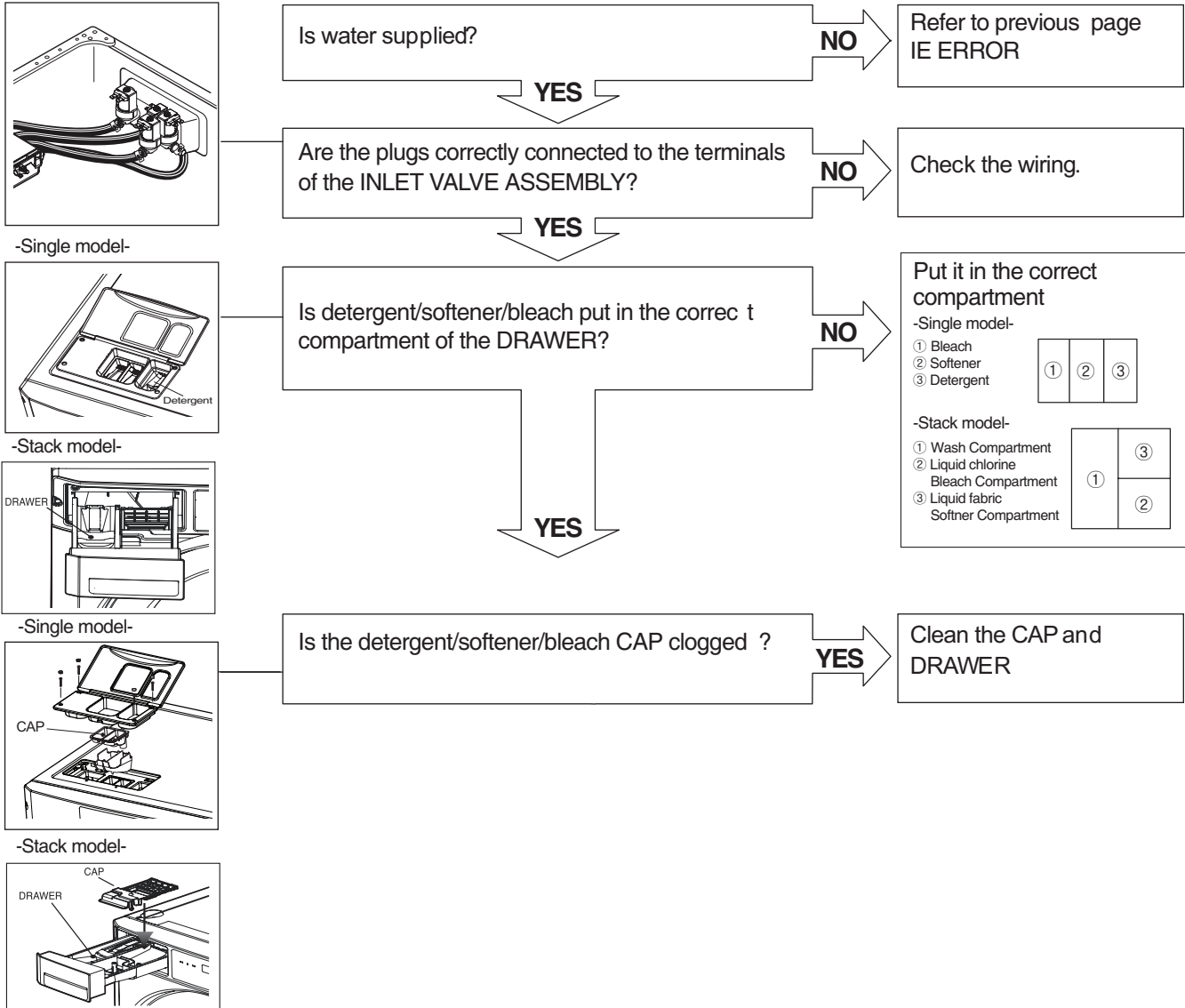

ABNORMAL SOUND

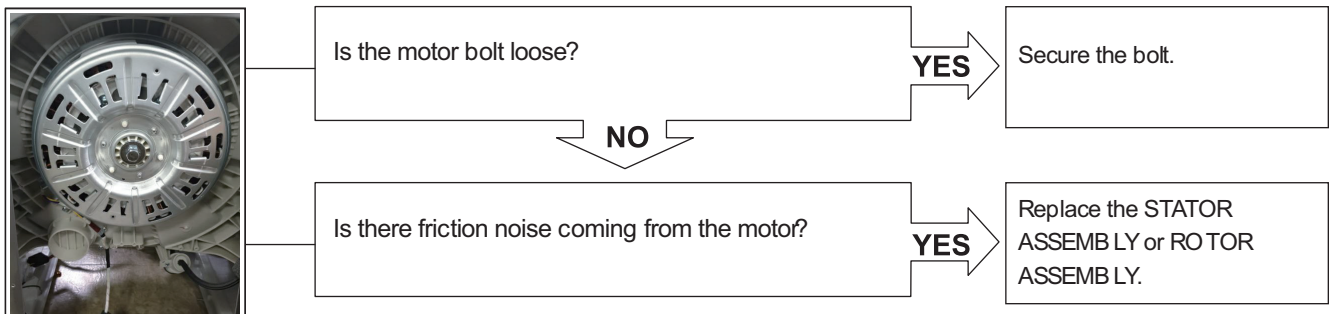

SUDS OVERFLOW FROM THE APPLIANCE

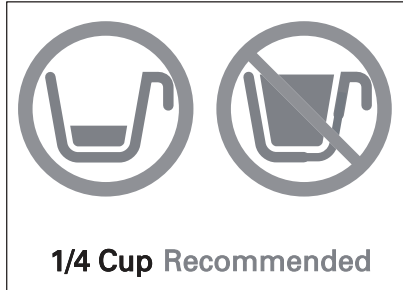

Is HE(High Efficiency) detergent used?

YES

Is the proper amount of detergent used as recommended?

YES

Recommend to reduce the amount of detergent.

- * This appliance has an automatic suds sensing function which prevents overflow.
- * When excessive suds are sensed, the suds removing implementations such as drain, water input, and pause will operate, without rotating the drum



WATER OVERFLOW FROM THE DRAWER OR DISPENSER

Is sheet detergent used ?

YES

Is the sheet detergent in dispenser?

YES

1. Remove the sheet detergent from the dispenser
2. Clean the dispenser

Cleaning the Dispenser

- * The dispenser should be cleaned periodically to remove buildup from detergent and other laundry products.
- * Do not add 'fabric sheet softener' into the dispenser.

Packing Material Removal

Checkpoint. Has the packing material been removed?

Make sure the tub support and all four shipping bolts have been removed.
This packing material helps to support the outer tub during transit, so that it does not shift.
If not removed, the inner drum will turn, but the outer tub will not be able to shift as needed.

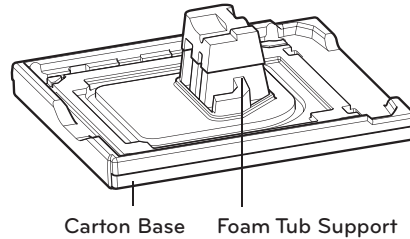

4 Shipping bolts



- Shipping bolts are made of two parts. One is 'rubber + plastic' and the other is 'metal'.
- All parts must be removed from the washer!!

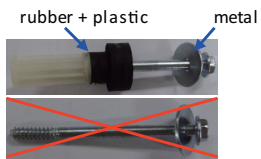

→ You can separate power cord from the washer after removing shipping bolts.

Leveling

Is the unit leveled?

If the unit is not leveled properly, it will vibrate.
Many vibration issues are the result of the unit not being leveled properly.

To check the leveling:

1. Perform a diagonal test. Push down on each corner of the unit.



How to perform a diagonal test:



Place your right hand on the back-right corner and your left hand on the front-left corner of the unit, then attempt to rock the unit from corner to corner. Then, move your right hand to the front-right side and your left hand to the back-left corner and attempt to rock the unit from corner to corner.



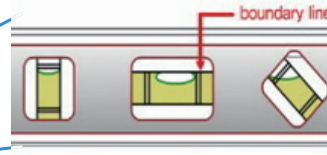

If the unit is level, it will not rock. However, if the unit is not level, it will rock. If the unit rocks, it will be necessary to adjust the leveling feet of the unit. Adjust the foot under the hand that is on the front of the machine.

2. Use a bubble level and make sure unit is leveled from left to right, front to back, and diagonally.

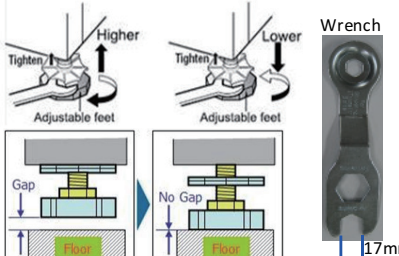
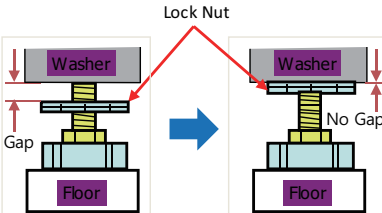

Check the horizontality with a level.
Second line is boundary line.

Adjusting legs

<p>1 Perform the diagonal test</p> <p>1. Attempt to rock the unit from corner to corner. 2. Check the unit is rocked or not. If the unit is not level, it will rock.</p>  <p>※ Test direction Right Front – Left Rear Left Front – Right Rear</p>	<p>2 Adjust Legs for leveling</p> <p>If the unit is not level, use the wrench to adjust the legs at the front of the unit.</p> 	<p>3 Perform the load test in Rinse+Spin</p> <p>1. Put about 2~3kg (4~6lb) clothes in the drum after leveling. 2. Perform a Rinse + Spin course. 3. Watch the vibration of the unit when it reaches the high spins speed 4. If the unit is vibrating a lot, make small adjustments to the legs until they subside.</p> <p>※ Don't overturn legs as this could result in the unit becoming even more unlevelled.</p>
<p>4 Tighten the lock nuts</p> <p>Once the unit is leveled, tighten the lock nut against the base of the machine to lock the position of the leveling foot.</p> 	<p>5 Perform the diagonal test again</p> <p>Finally, check the unit is rocking or not.</p> 	<p>※ Conventional Leg</p>  <p>※ New Leg</p> 

Uneven Floors

Does the **floor vibrate** with the machine?

The unit requires a solid and horizontal floor for proper operation. Unit will generate vibrations if placed on RAISED / UNEVEN foundations .

It may be necessary to move the machine to a different area in the home or have a floor reinforced to properly support the operation of the unit.

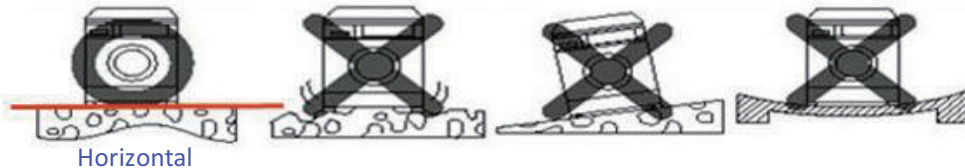

How to check if this could be caused by the floor, rather than the machine

Place a glass of water on the floor about a foot or so out in front.

If it shakes, sloshes and vibrates, then the floor is causing the vibrations and not the unit.

If the floor is vibrating with the machine, the vibrations are not being caused by a problem with the machine, but rather by the floor. Because the drum spins in an up and down rotation there is more pressure put on the floor during the machine's operation. Because of this, it is necessary for the flooring to be secure enough to support the machine's operation.

If the unit is on a wooden floor (or tile floor with wooden subflooring) then vibrations are more likely to occur. This is because wood is a pliable surface. So when the unit goes into the spin cycle, spinning in an up and down rotation, the wooden floor absorbs the energy and carries it throughout the floor, even throughout the house.

To minimize or eliminate vibrations on wooden floors, it is necessary that the floors be reinforced to support the machine's operation.

Adjusting legs

Foreign objects beneath the feet?

Do not place items under the feet to fill a gap between the foot of the unit and the floor. This will not resolve the issue and may make it worse.
Drip pans can cause the unit to slip in the pan and the pan to slip on the floor.
Use rubber cup for reducing the gap and adjust legs for leveling.

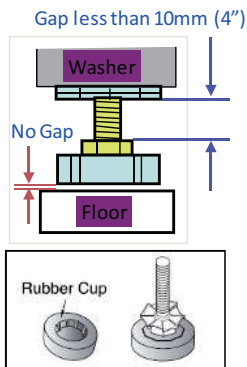
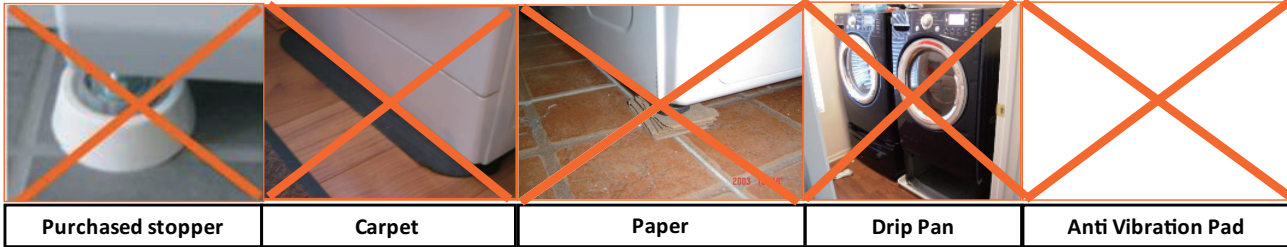

Use rubber cup for reducing the gap and adjust legs for leveling



Adjusting legs

Vibration - Conditions Under Leg

Is the floor under the unit clean and slipless?

Make sure the floor is clean and dry to prevent the unit from slipping on the floor.
Anti-skid pads beneath the feet of the unit will help provide a grip for the unit and prevent slipping caused by smooth, slippery surfaces.

Clean and dry to prevent walking and vibrating.
Dust and oils make product walk and vibrate.

To prevent product walking,
Place the anti-skid pads under both front feet especially linoleum or tile covering floor.
Rubber caps are also an effective method of preventing product vibration and walking.

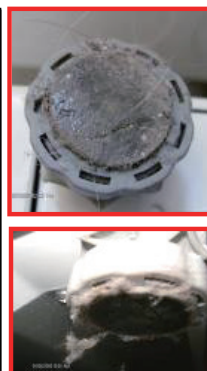
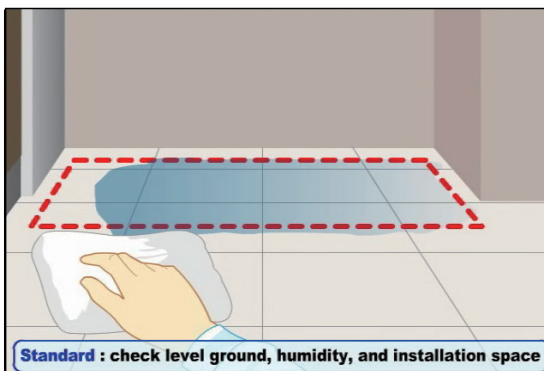

If the pedestal is installed, place the anti-skid pads under both front feet of pedestal.

Unbalance(load)

How often does this occur?
What type of load?

If the vibrations do not happen on every load, the load type or size is likely causing an unbalanced load. This happens if the weight is not evenly distributed across the drum surface, causing vibrations. Unbalanced loads can occur if the load is too small, contains large items such as blankets or sheets, or is a mixed fabric load.

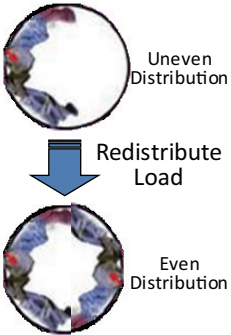

Mixed load



Separate by fabric type and size

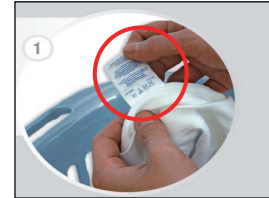

Sort Fabrics

Additional information about unbalance loads

Unbalanced loads will cause vibrations during the spin cycle. Since the drum spins in an up and down rotation, proper balancing of the load inside the drum is very important for the drum to spin smoothly.

If the load is not evenly distributed across the drum surface, weight will be more in one area and less in the other.

So when it reaches the higher RPMs the drum will spin slightly out of alignment.

Try to distribute the load across the drum surface to reduce vibrations.

Removing items or adding more items to the load may be necessary to help distribute the load properly.

Required Clearance

Are the required clearances being met?

If the required installation clearances are not met, something could be knocking against the side, back or top of the unit. This causes vibration. While it may vary, most units require 2cm on each side and 10cm at the back of the unit. Do not store items on top of unit, especially during operation.

Side View

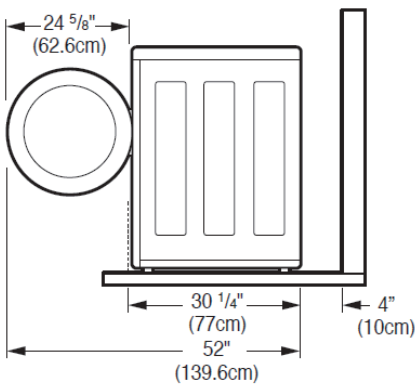

Front View

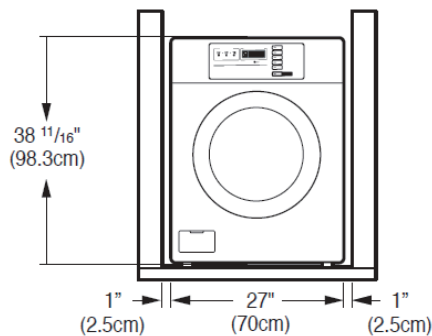

In case of Hose passes side

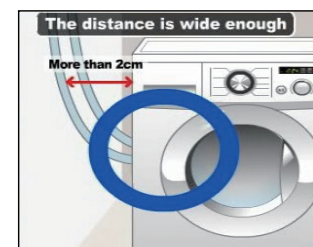
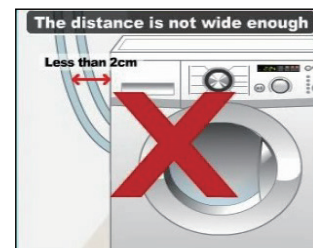

10. SMART FUNCTIONS

LG Laundry Lounge (Smart Solution)

Checking and choosing the proper location

This is the remote monitoring and control system. There are three components as follows.

- 1) LG Laundry Lounge Installer(App) : This is a registration app for installers used to register the product on the server. Only available for authorized users.
*Search for **LG Laundry Lounge Installer** in Google Play Store or Apple App Store.
- 2) LG Laundry Lounge(App) : This is an end-user app used to check real-time status of registered stores and products.
*Search for **LG Laundry Lounge** in Google Play Store or Apple App Store.
- 3) LG Laundry Lounge(Web) : This is an administrator website where you can remotely monitor and control registered locations and products. Please access the website address below. <https://cls.lgthinq.com>

How to register the product

- 1) Run the LG Laundry Lounge Installer application on a smartphone.
- 2) Create an account and Sign-in.
- 3) Add Location (Input information : Location Name, Address, E-mail, Phone Number)
 - A unique Location PIN number is generated after 'Add Location.'
This is used when the end-user registers the location. Share the Location PIN Number for the end-user.
 - You can check the Location PIN number under the location name (Six-digit number).
- 4) Add a Device
 - Shift the product to Soft Access Point (AP) mode. Press and hold the top three course buttons (see image below).



You will see **8888** on the machine display. The device functions as an AP and sends out a wireless signal.

- Pairing the product to the App :
 - a) Android : Product will automatically pair with the App. Skip to the next step.
 - b) iOS : Turn on Wi-Fi settings, then connect to the product's network (shown below), If required, enter the following :

Network name	Password
Washer : LG_Smart_Laundry2_XXXX Dryer : LG_Smart_Dryer2_XXXX	Enter XXXX twice (Case -sensitive)

After connecting, return to the LG Laundry Lounge Installer App.

- The application shows the Wi-Fi network list. Select the Wi-Fi network you wish to use. If your network requires a key, enter the password and press the Connect button.
 - ※ 5GHz networks may not be supported.
 - ※ Make sure the Wi-Fi network name does not contain non-English or special characters.
- The application now works to connect the product and register it as a Wi-Fi product.
- When the connection is completed, the product goes to standby mode automatically.
- When the product registration is completed, you can see the product for the installation location.
 - ※ If you see Error next to the nickname of the product, please delete and re-register. Also, check the router signal strength.

SMART FUNCTIONS

Wireless LAN Module Specifications

Model	LCW-004
Frequency Range	2412 - 2462 MHz
Output Power (Max)	< 30 dBm

FCC Notice (For transmitter module contained in this product)

This equipment has been tested and found to comply with the limits for a Class B digital device, pursuant to Part 15 of the FCC Rules. These limits are designed to provide reasonable protection against harmful interference in a residential installation. This equipment generates, uses, and can radiate radio frequency energy and, if not installed and used in accordance with the instructions, may cause harmful interference to radio communications. However, there is no guarantee that interference will not occur in a particular installation. If this equipment does cause harmful interference to radio or television reception, which can be determined by turning the equipment off and on, the user is encouraged to try to correct the interference by one or more of the following measures:

- Reorient or relocate the receiving antenna.
- Increase the separation between the equipment and the receiver.
- Connect the equipment to an outlet on a circuit different from that to which the receiver is connected.
- Consult the dealer or an experienced radio/TV technician for help.

This device complies with part 15 of the FCC Rules. Operation is subject to the following two conditions:

- 1) This device may not cause harmful interference and
- 2) This device must accept any interference received, including interference that may cause undesired operation of the device.

Any changes or modifications in construction of this device which are not expressly approved by the party responsible for compliance could void the user's authority to operate the equipment.

FCC RF Radiation Exposure Statement

FCC RF Radiation Exposure Statement This equipment complies with FCC radiation exposure limits set forth for an uncontrolled environment. This transmitter must not be co-located or operating in conjunction with any other antenna or transmitter. This equipment should be installed and operated with a minimum distance of 20 cm (7.8 inches) between the antenna and your body. Users must follow the specific operating instructions for satisfying RF exposure compliance.

Industry Canada Statement (For transmitter module contained in this product)

This device contains licence-exempt transmitter(s)/receiver(s) that comply with Innovation, Science and Economic Development Canada's licence-exempt RSS(s).

Operation is subject to the following two conditions:

- 1) This device may not cause interference.
- 2) This device must accept any interference, including interference that may cause undesired operation of the device.

IC Radiation Exposure Statement

IC Radiation Exposure Statement This equipment complies with IC radiation exposure limits set forth for an uncontrolled environment.

This equipment should be installed and operated with a minimum distance of 20 cm (7.8 inches) between the antenna and your body.

NOTE

- THE MANUFACTURER IS NOT RESPONSIBLE FOR ANY RADIO OR TV INTERFERENCE CAUSED BY UNAUTHORIZED MODIFICATIONS TO THIS EQUIPMENT. SUCH MODIFICATIONS COULD VOID THE USER'S AUTHORITY TO OPERATE THE EQUIPMENT.

Open Source Software Notice Information

To obtain the source code under GPL, LGPL, MPL, and other open source licenses, that is contained in this product, please visit <http://opensource.lge.com>. In addition to the source code, all referred license terms, warranty disclaimers and copyright notices are available for download.

LG Electronics will also provide open source code to you on CD-ROM for a charge covering the cost of performing such distribution (such as the cost of media, shipping, and handling) upon email request to opensource@lge.com. This offer is valid for a period of three years after our last shipment of this product. This offer is valid to anyone in receipt of this information.

11. DISASSEMBLY INSTRUCTIONS

CONTROL PANEL ASSEMBLY

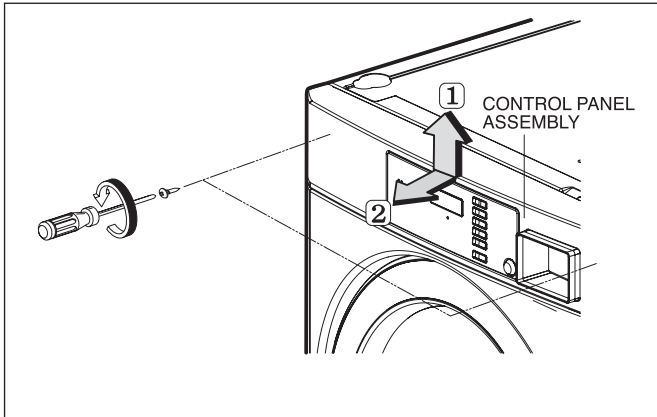

1. Unscrew 2 screws
2. Disassemble the CONTROL PANEL ASSEMBLY
- Pull out the CONTROL PANEL .

* Do not pull out the CONTROL PANEL too forcefully as it can be broken.

3. Disconnect the DISPLAY PWB ASSEMBLY connector from CABLE (HARNESS).

DISPLAY PWB ASSEMBLY

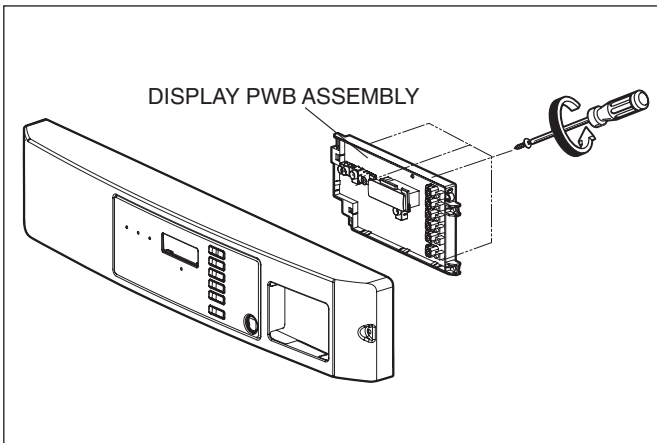

1. Disassemble the CONTROL PANEL ASSEMBLY
2. Unscrew the 4 screws from the CONTROL PANEL ASSEMBLY.
3. Disassemble the DISPLAY PWB ASSEMBLY.

TOP PLATE ASSEMBLY

⚠ WARNING

- When you disassemble the top plate, be sure to take gloves and careful plate's edge. Failure to do so can cause serious injury.

-Stack model-

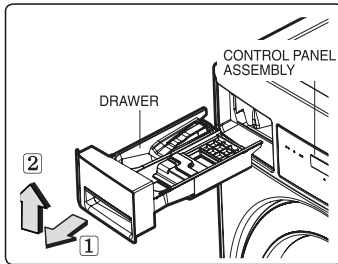

1. Pull out the DRAWER
2. Disassemble the CONTROL PANEL ASSEMBLY (refer to previous page)

-Single model-

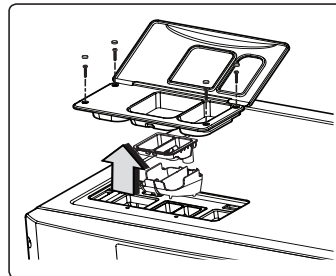

1. Disassemble the LID OUT ASSEMBLY
 - Remove 4 rubber caps
 - Unscrew the Frame (4point)
2. Disassemble the CONTROL PANEL ASSEMBLY (refer to previous page)

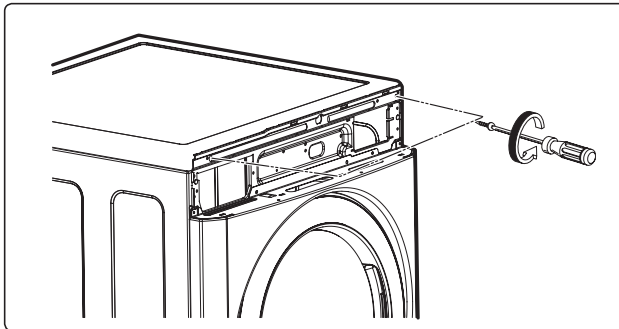

3. Unscrew the TOP PLATE (2point)

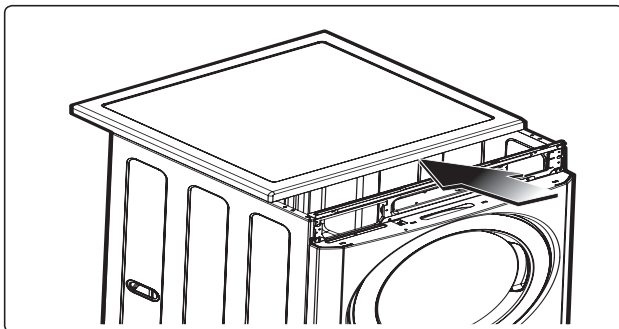

4. Push the TOP PLATE backward forcefully.

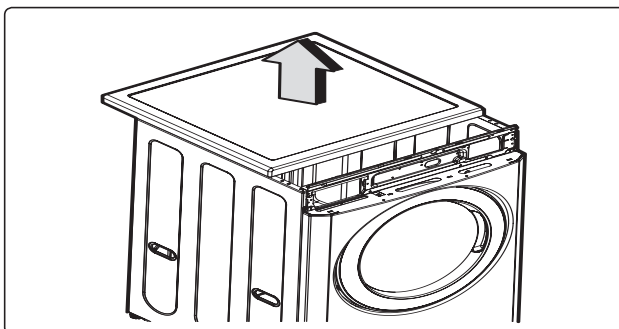

5. Lift the TOP PLATE

MAIN PWB ASSEMBLY



1. Disassemble the CONTROL PANEL ASSEMBLY (Refer to page 38)
2. Disassemble the TOP PLATE ASSEMBLY (Refer to previous page)
3. Unscrew a screw on PRESSURE SWITCH ASSEMBLY
4. Remove all wire from hooks.
5. Detach fuse from Protective Cover. (fit fuse into holder on Cover when reassembling)
6. Remove the Protective Cover.

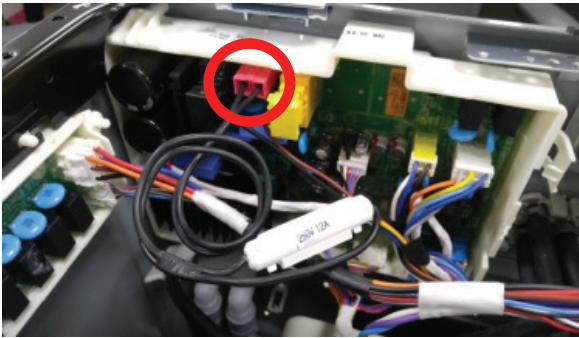

7. To replace FUSE ASSEMBLY, disconnect fuse connector from MAIN PWB ASSEMBLY and change with new FUSE ASSEMBLY.



8. Disconnect the connectors.

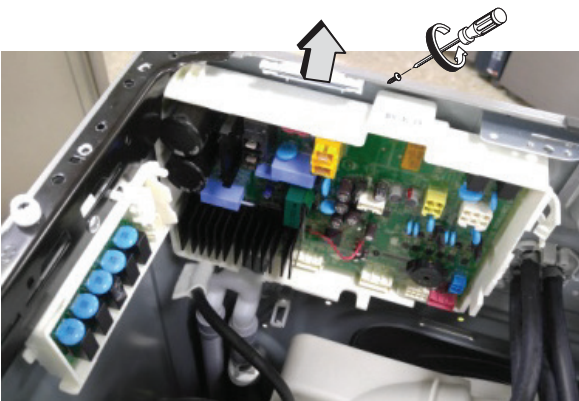

9. Unscrew 1 screw on the back.
10. Disassemble the MAIN PWB ASSEMBLY.

DISPENSER ASSEMBLY

-Single model-

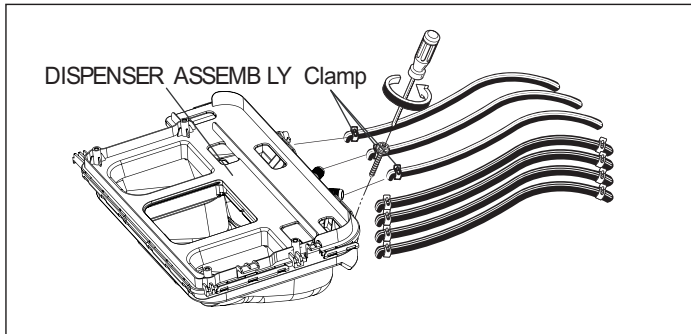

1. Disassemble the CONTROL PANEL ASSEMBLY (Refer to page 38)
2. Disassemble the TOP PLATE ASSEMBLY (Refer to page 39)
3. Disassemble the clamps and hoses.
4. Disassemble the bellows at the lower side of DISPENSER

-Stack model-

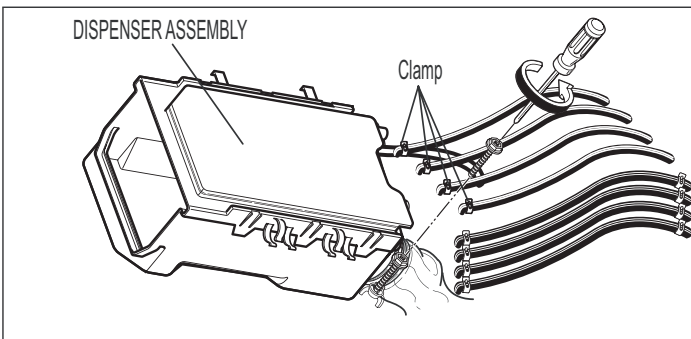

INLET VALVE ASSEMBLY

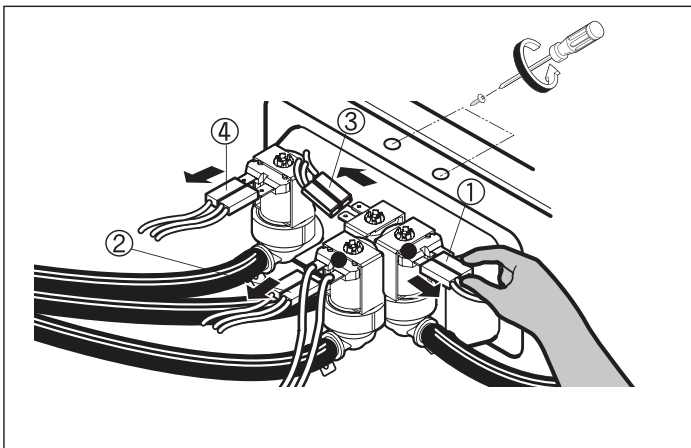

1. Disassemble the CONTROL PANEL ASSEMBLY (Refer to page 38)
2. Disassemble the TOP PLATE ASSEMBLY (Refer to page 39)
3. Disassemble the 4 connectors from the VALVES.
4. Disassemble the clamps and hoses.
5. Unscrew the 2 screws in the back.

Connector Color

- ① Blue Housing(OR-BK)
- ② White Housing (WH-BK)
- ③ Blue Housing (GY-BK)
- ④ Red Housing (BL-BK)

CABINET COVER

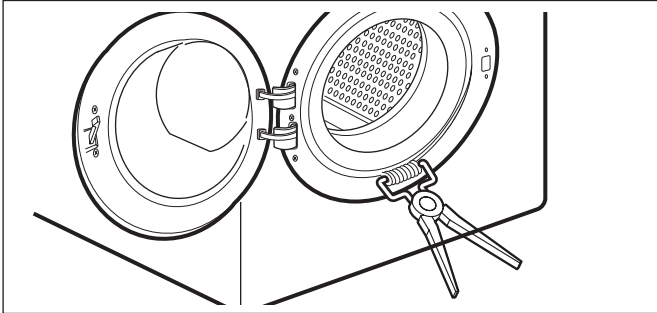

1. Disassemble the CONTROL PANEL ASSEMBLY
(Refer to page 38)
2. Open the DOOR.
3. Disassemble the CLAMP ASSEMBLY.

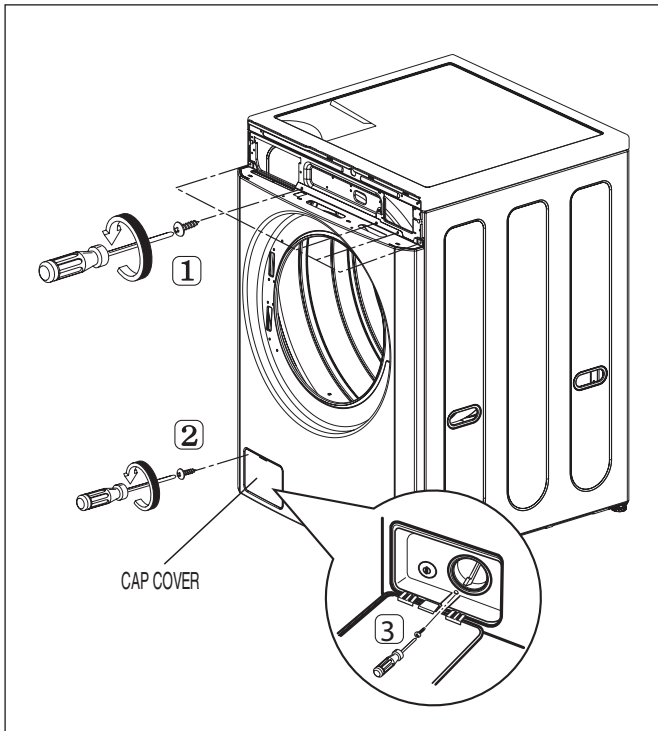

4. Unscrew the 4 screws from the CABINET COVER.
5. Unscrew the screw from CAP COVER.
6. Unscrew the screw from inside CAP COVER.

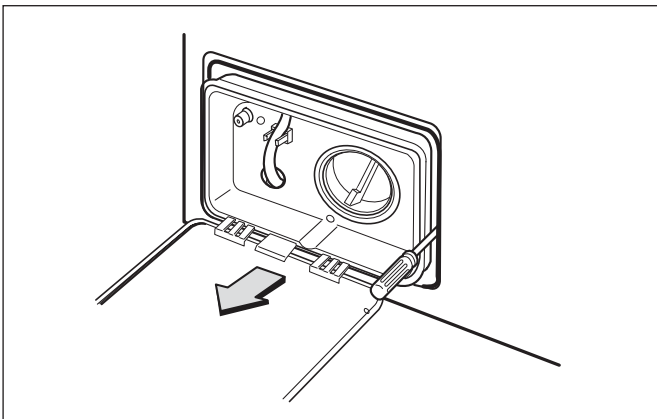

7. Put a flat (-) screwdriver or putty knife into both sides of the CAP COVER, and pull it out.

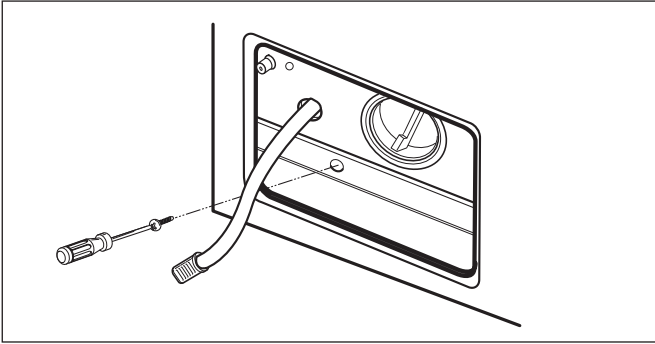

8. Unscrew the screw from the lower side of the CABINET COVER .

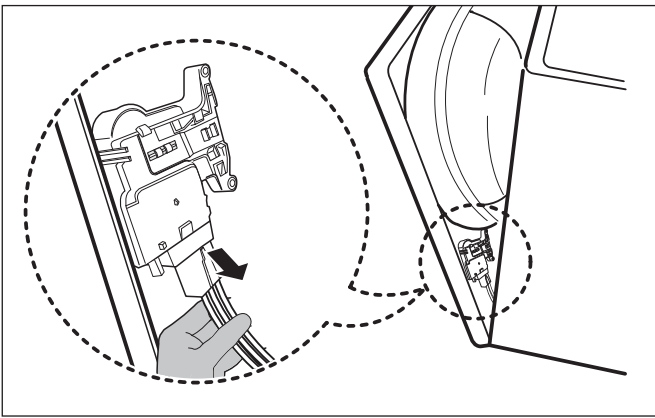

9. Tilt the CABINET COVER.
10. Disconnect the DOOR S/W connector.

※ **NOTE:** When assembling the CABINET COVER, connect the connector.

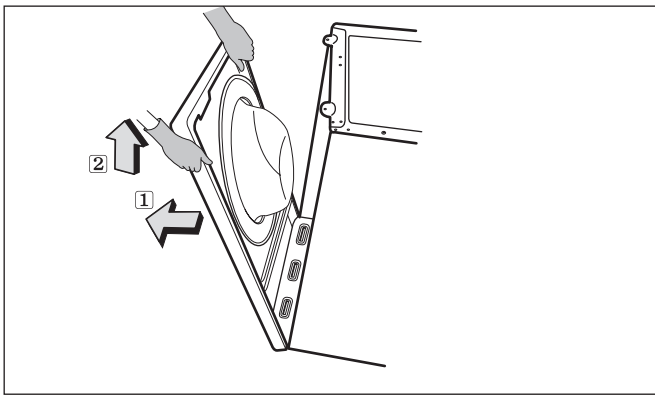

11. Lift and separate the CABINET COVER.

GASKET

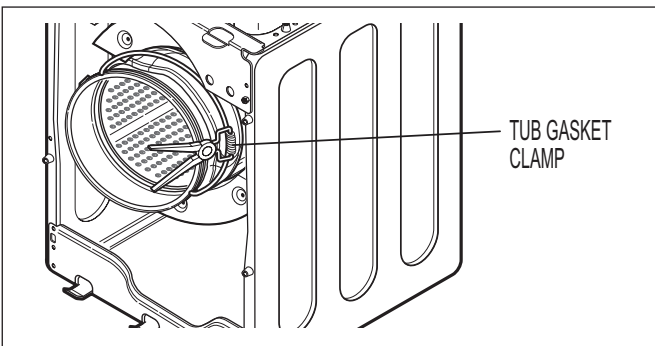

1. Disassemble the CABINET COVER
(refer to previous page)
2. Disassemble the CLAMP ASSEMBLY.
3. Disassemble the GASKET.

DOOR ASSEMBLY

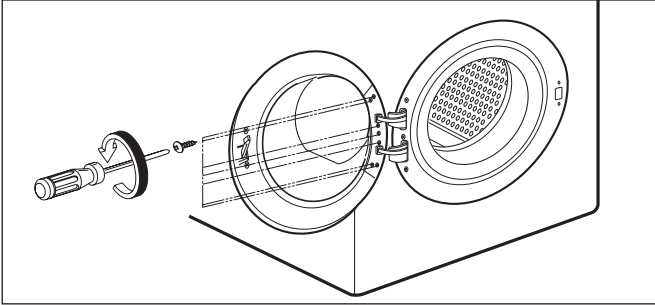

1. Open the DOOR.
2. Unscrew the 7 screws from the HINGE COVER.

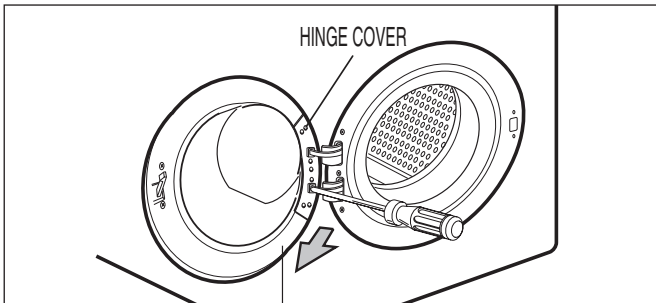

3. Put a flat (-) screwdriver into the opening of the hinge, and pull out the HINGE COVER.

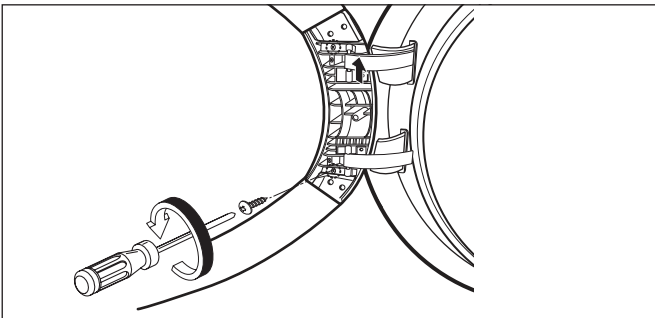

4. Unscrew a screw from the lower side of DOOR.
5. Lift door and remove.

※ **Be careful!** The door is heavy.

DOOR LOCK SWITCH ASSEMBLY

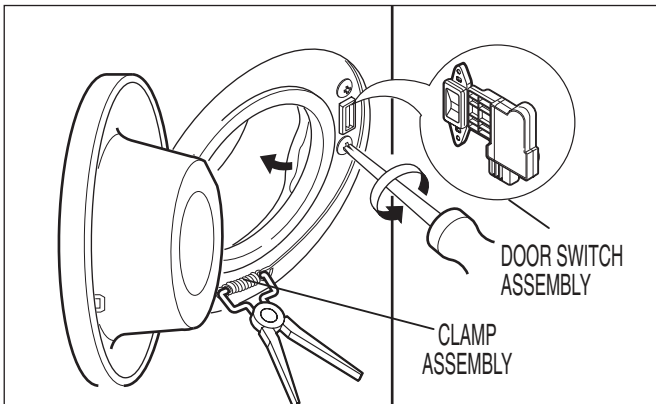

1. Open the DOOR and disassemble the CLAMP ASSEMBLY.
2. Unscrew the 2 screws.
3. Remove connector from DOOR SW ASSEMBLY.

※ **NOTE**
Reconnect the connector after replacing the DOOR SWITCH ASSEMBLY.

PUMP ASSEMBLY



1. Disassemble the CABINET COVER
2. Separate the PUMP HOSE and the BELLOWS , the CIRCULATION HOSES from the PUMP ASSEMBLY.
3. Remove the 2 bolts from the pump assembly.
4. Disassemble the pump assembly.

HEATER

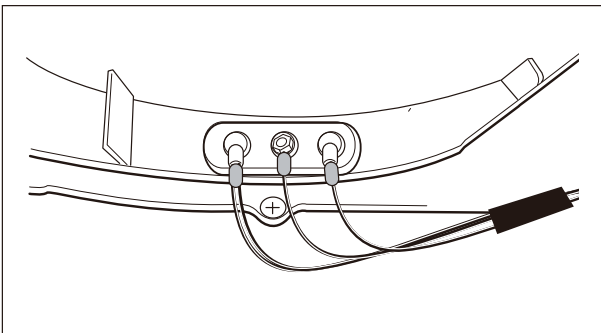

1. Disassemble the cabinet cover.
2. Separate 2 connectors from the heater.
3. Loosen the nut and pull out the heater.

※ CAUTION

- When assembling the heater insert the heater into the heater clip on the bottom of the tub.
- Tighten the fastening nut so the heater is secure.

NOISE FILTER

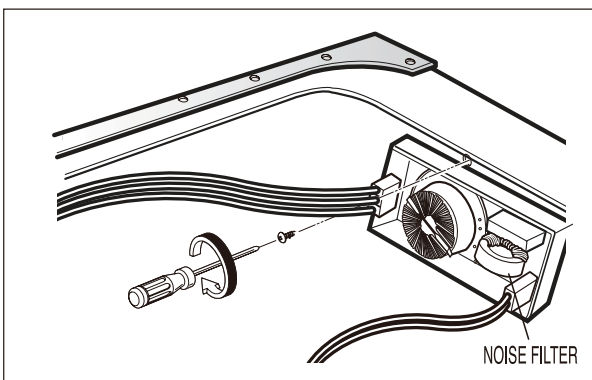

1. Disassemble the CONTROL PANEL ASSEMBLY (refer to previous page)
2. Disassemble the TOP PLATE ASSEMBLY (refer to previous page)
3. Disassemble two (or three) connectors from the NOISE FILTER.
4. Unscrew a screw from the TOP BRACKET.

MOTOR ASSEMBLY

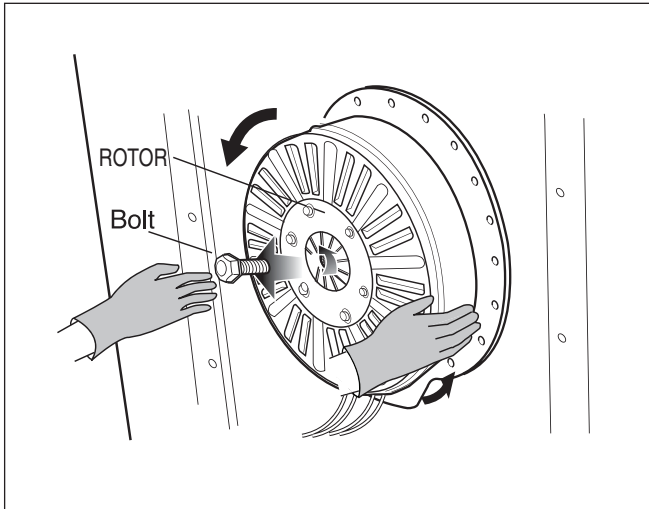

1. Disassemble the BACK COVER.
2. Remove the bolt.
3. Pull out the ROTOR.

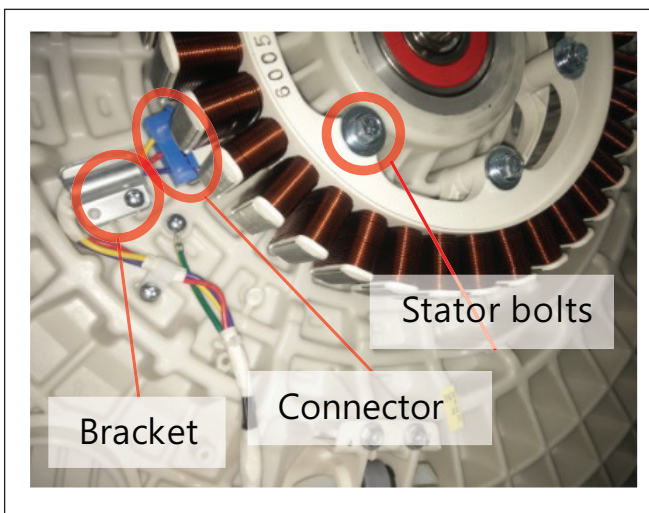

4. Unscrew a screw from the bracket.
5. Remove the 6 bolts on the stator.
6. Unplug the connector from the STATOR.

DAMPER



1. Disassemble the damper hinges from the tub and base.

※ NOTE

When replacing dampers, replace them as a set rather than individually.
There are several iterations of dampers available. Be sure all four in the set are the same class.

12. EXPLODED VIEW

12-1. CABINET & CONTROL PANEL ASSEMBLY

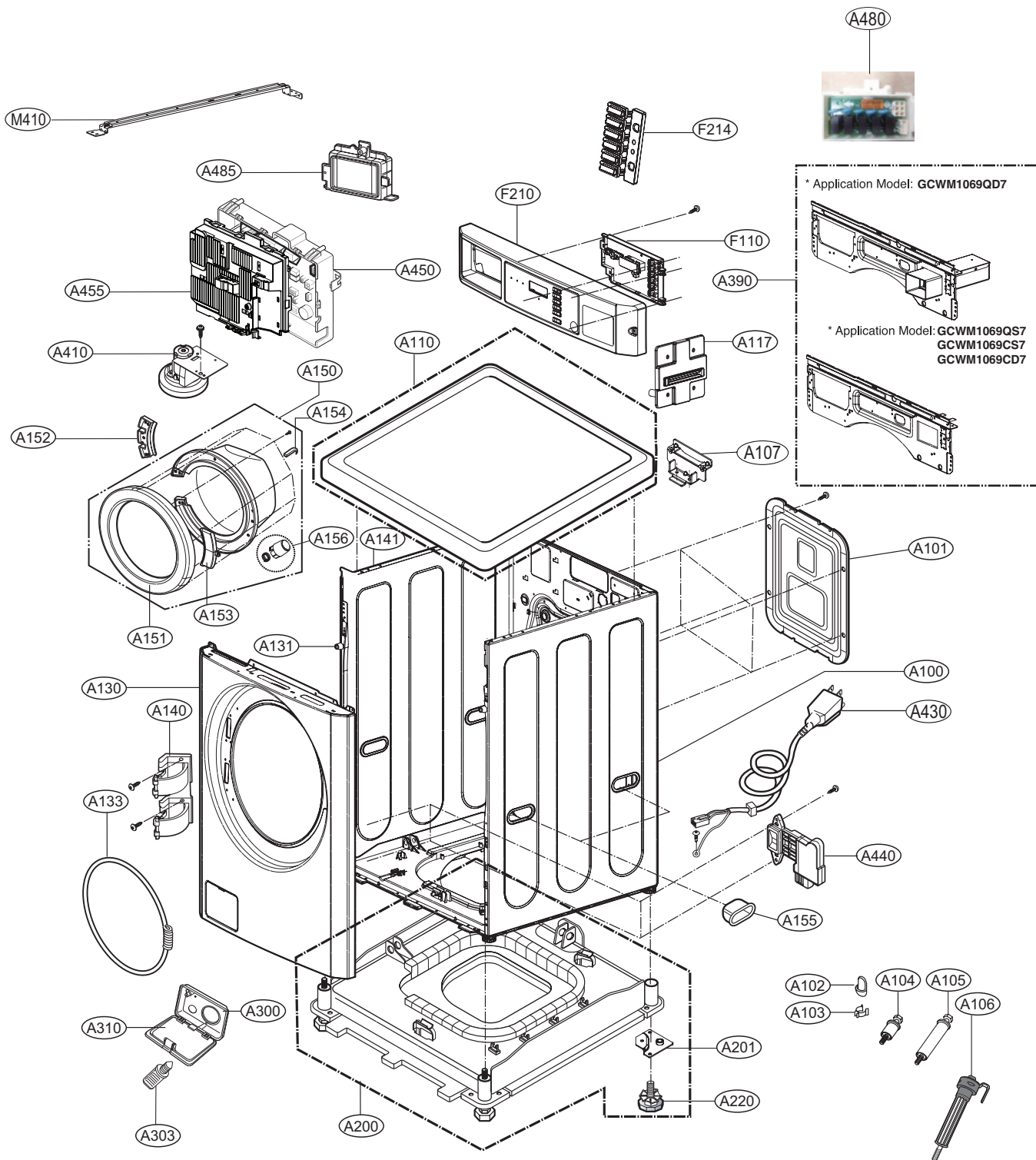

12-1-2. CABINET & CONTROL PANEL ASSEMBLY

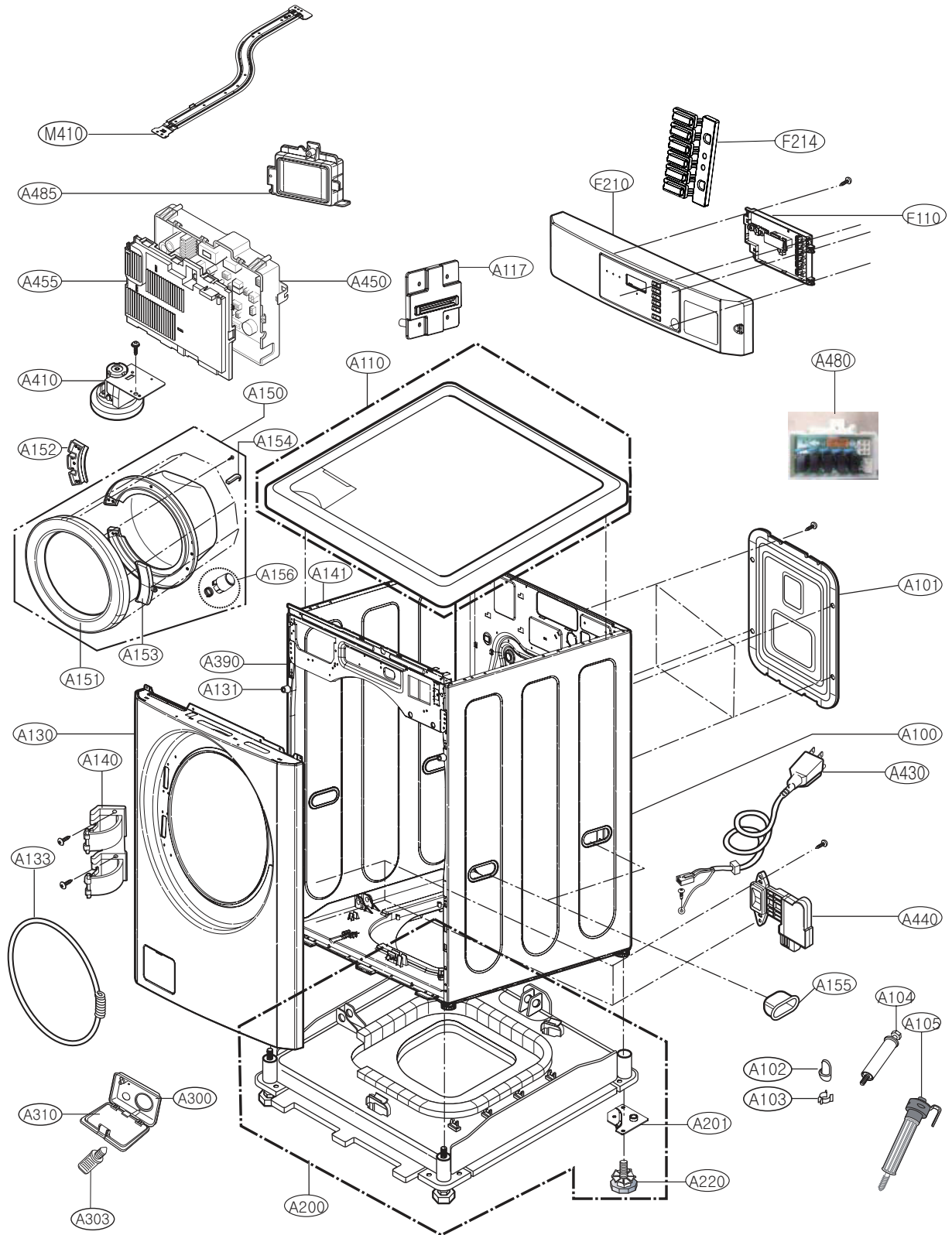

12-2. DRUM & TUB ASSEMBLY

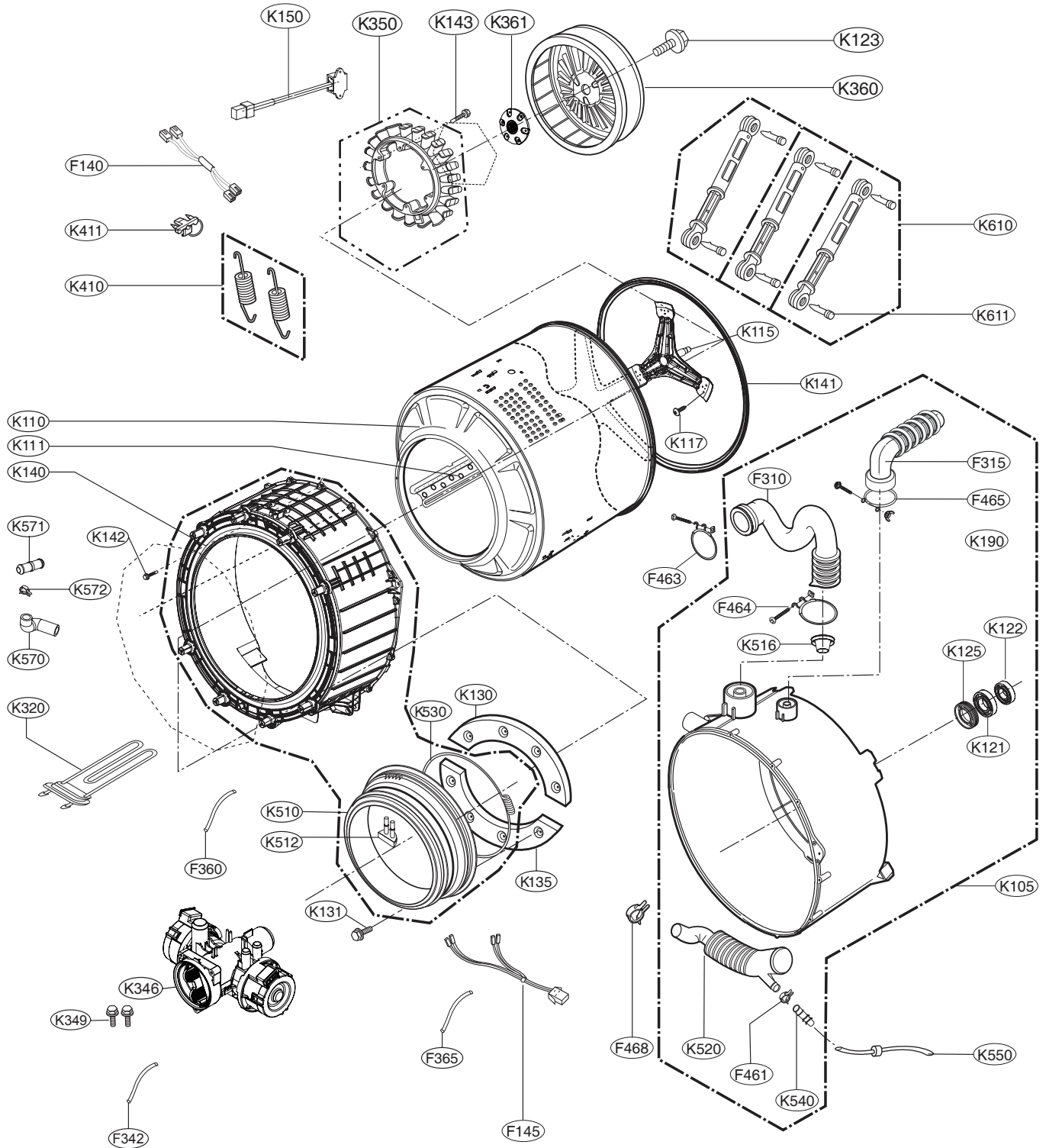

12-3. DISPENSER ASSEMBLY (FOR SINGLE MODEL)

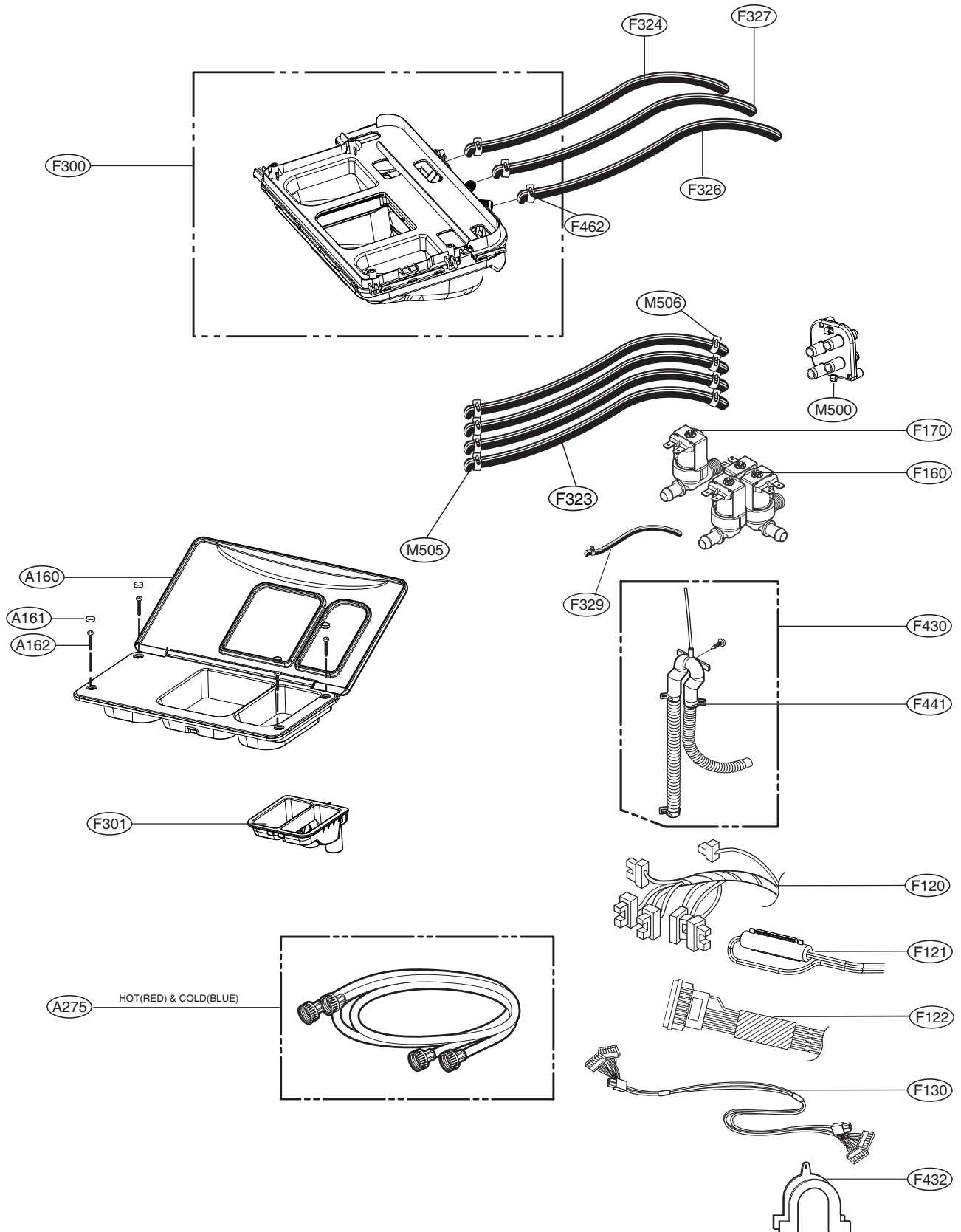



MFL68921865