

Maximum door weight = 40kg per leaf – total system 80kg

Maximum door width 2 x 2mtr Track = 760 - 1058mm (Up to 2035 mm clear opening)

About this document

This document addresses qualified personnel only. The mounting must be done by technically educated, trained and qualified personnel. Electrical wirings have to be completed by suitably qualified specialists.

These instructions describe how to install the track & sliding door gear – for operation of the drive motor & Wiring detail for the addition of switches & or sensors please refer the Evolve Motor and Wiring Fitting Instructions supplied

The manufacturer's specifications must be respected, in especially maximum weight restriction of the door leaf. Any other use of this product is considered inappropriate use.

It is not guaranteed that this product will work in combination with fittings, motors or other electronic devices supplied by other manufactures.

The appliance is only to be used with the power supply unit provided.

Before you commence work, please read through these instructions. Please store these instructions in a safe place and pass them on to any future owners. Damage resulting from non – compliance with these instructions and safety instructions will void the warranty. PC Henderson nor the motor unit manufacturer will assume liability for any consequential damage.

Fixings required (Not supplied by PCH)

We recommend that suitable wall fixings and screws with a Safe Working Load of at least 80kg are used.

Contents of Kit

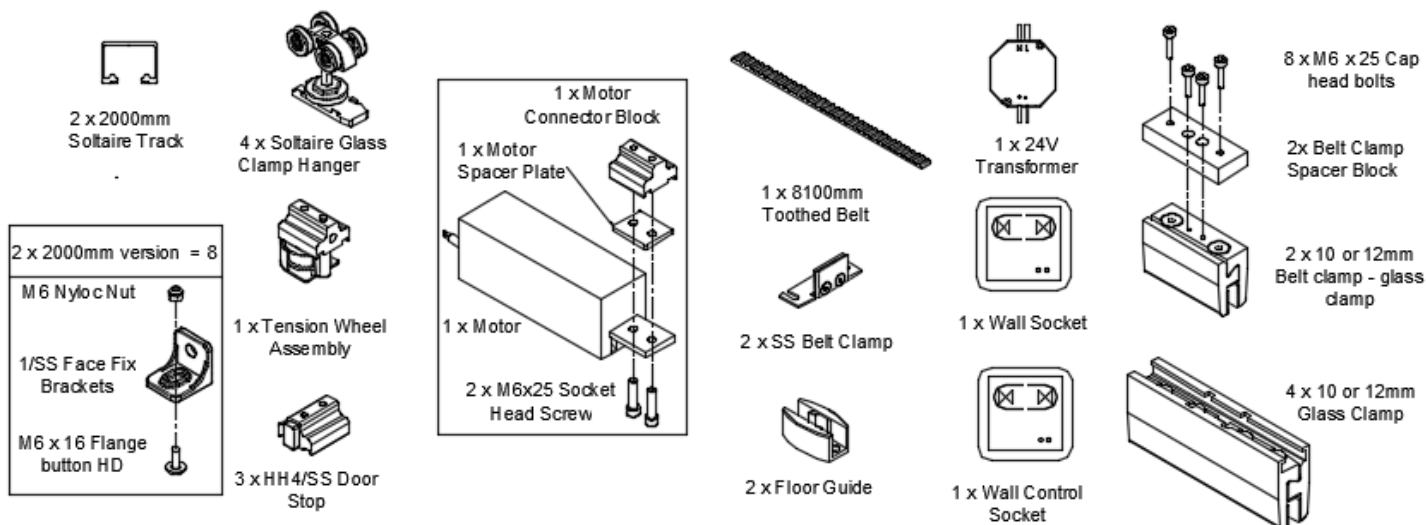

Tools required



Electricians
Screwdriver



Posi Head
Screwdriver



3, 4 & 5mm Allen
keys

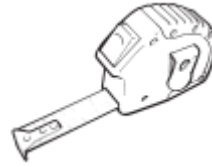

Tape Measure

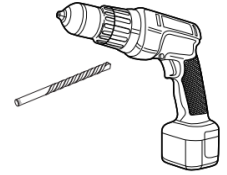

Electric Drill &
twist drill



Scissors

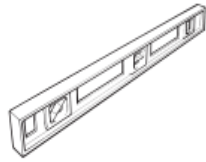

Spirit Level

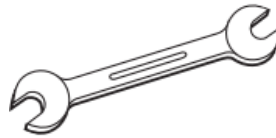

3, 10 & 13mm
Spanner

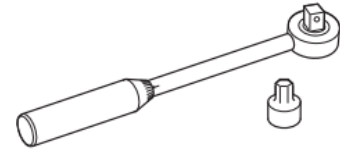

Torque Wrench
and 6mm bit

Installations – End elevations

OH = OPENING HEIGHT
 TC = TOP CLEARANCE
 BC = BOTTOM CLEARANCE
 P = PACKER
 B = DOOR THICKNESS
 TSH = TRACK SET HEIGHT
 X = OVERLAP (PCH
 RECOMMEND 13mm)

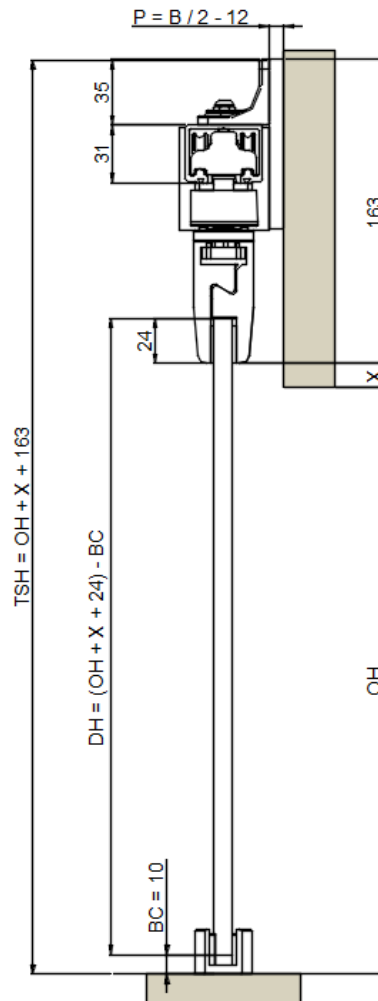
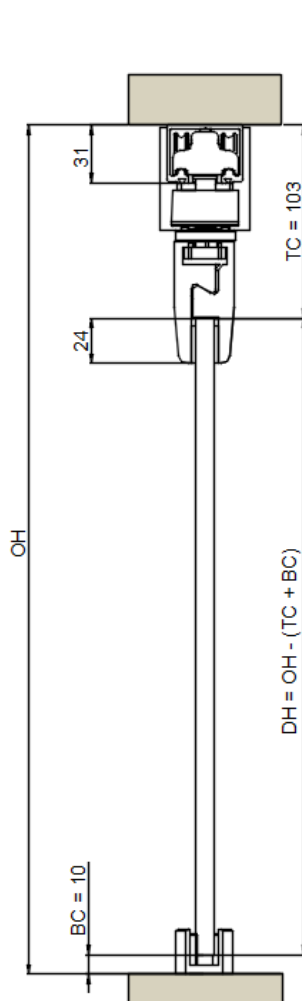

SPACER REQUIRED TO
 ACCOMODATE DOOR THK
 OVER 40mm (NOT PCH)

Installation - System layout

CLOSED POSITION

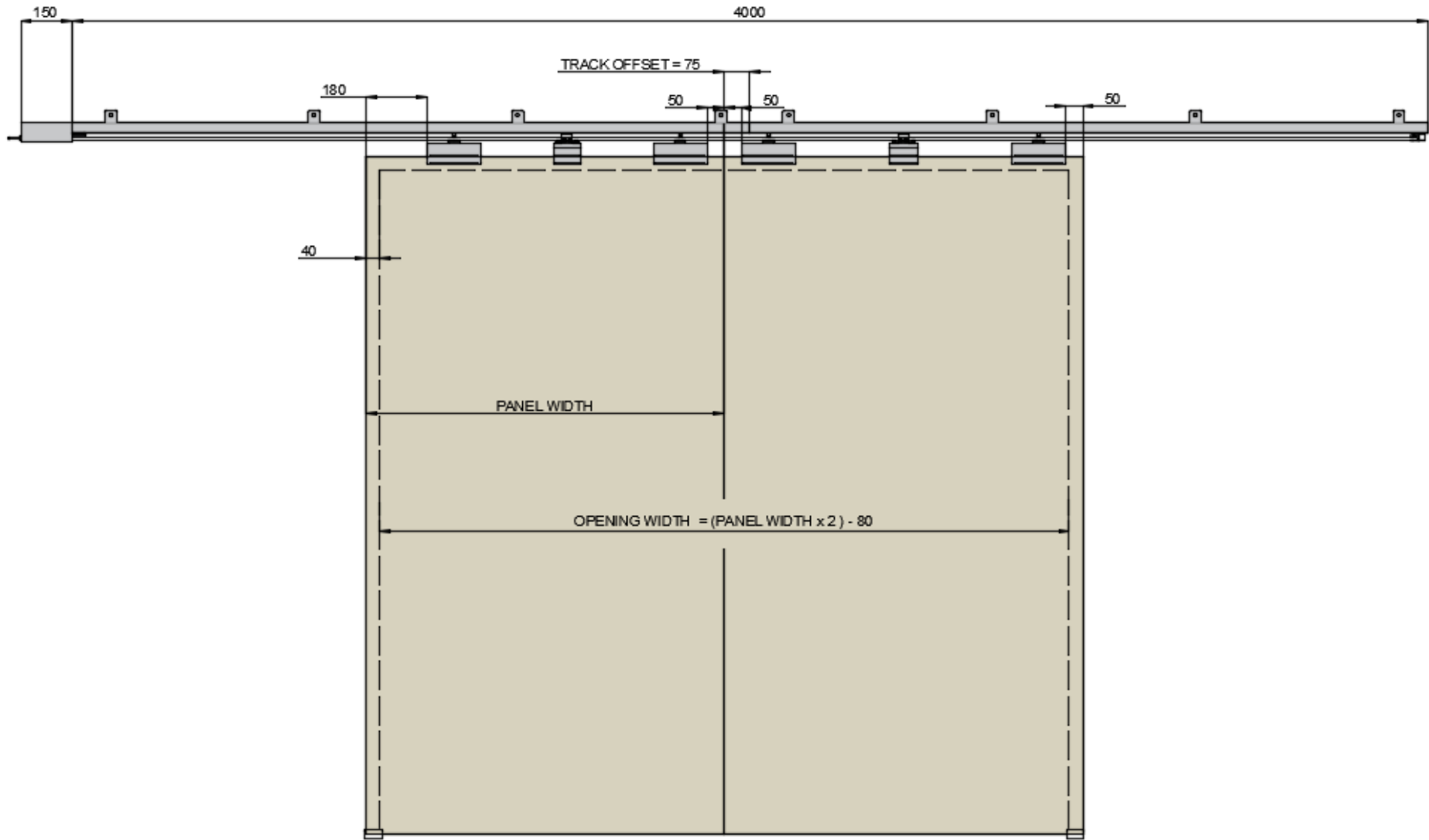

Quick overview – Wiring Diagram

For detailed operation and programming instructions please consult the separate Evolve Motor and Wiring Fitting Instructions supplied

Evolve Wiring Diagram

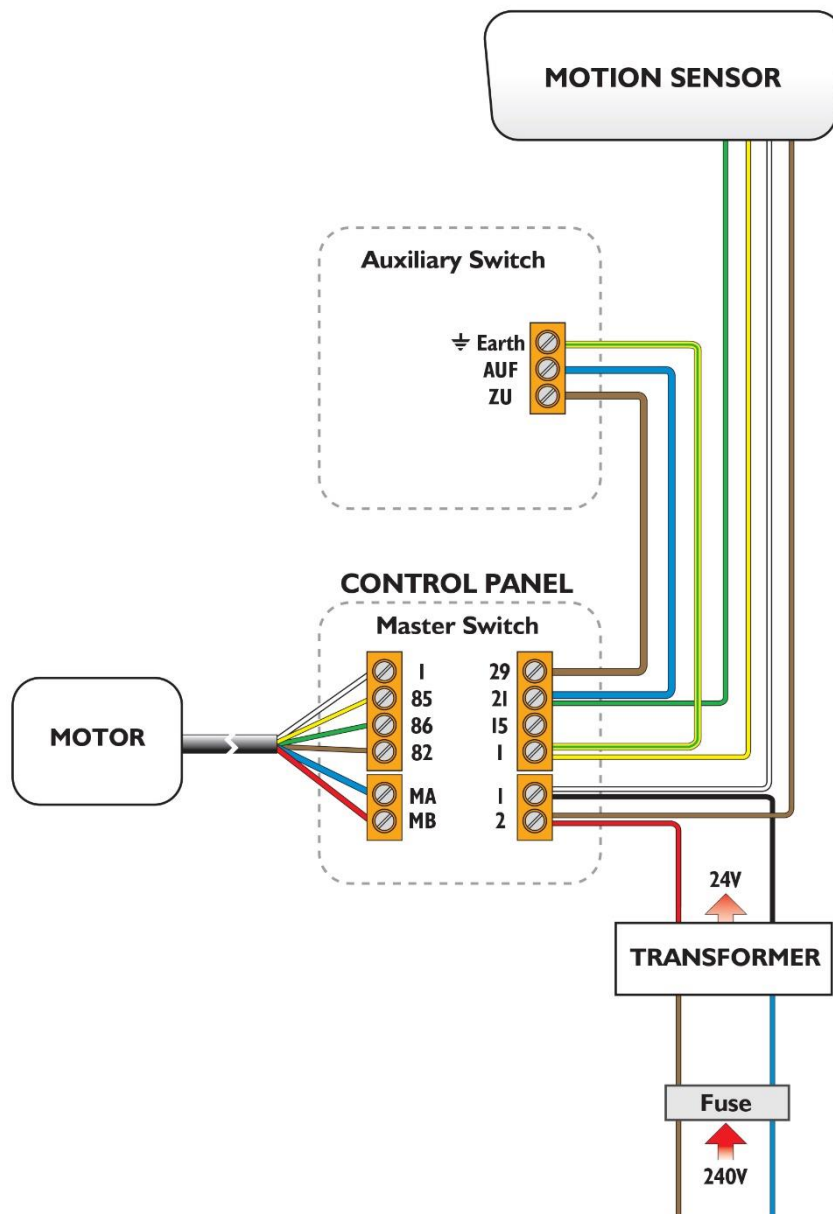

Quick overview – Wiring wall mounted socket

For detailed operation and programming instructions please consult the separate Evolve Motor and Wiring Fitting Instructions supplied

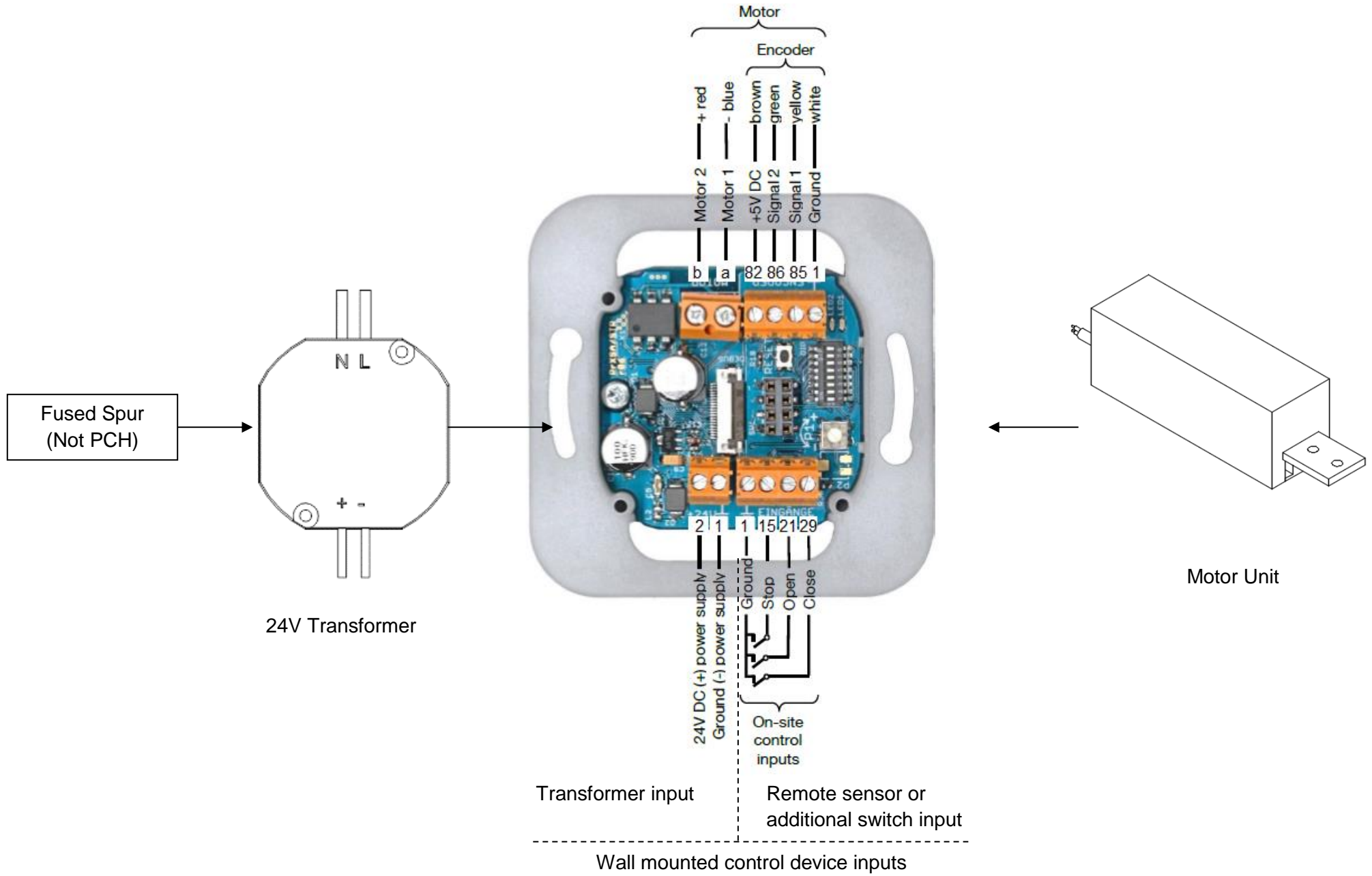

Quick overview – Wiring wall mounted socket

For detailed operation and programming instructions please consult the Evolve Motor and Wiring Fitting Instructions supplied

Initial Configuration

The configuration is set via the potentiometer P1, the DIP switch and the reset button. The function of these elements is described in the following section.

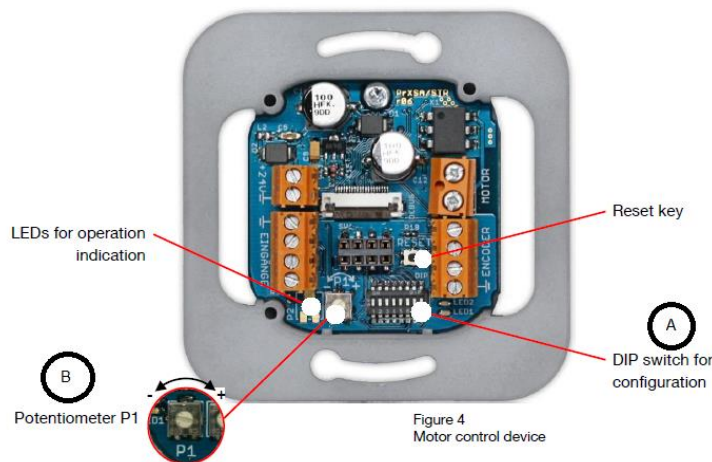

Changes to configuration will only take effect once the configuration mode has been selected, modified and then exited.

A – Configuration of DIP switches - Set desired parameters, while power is off.

OFF ↔ ON	Switch	Description	OFF (default)	ON
	1	Operation mode	Semi-automatic	Automatic
	2	Dead man's control	Disabled	Enabled
	3	Push & Go	Disabled	Enabled
	4	Reaction on obstruction	Reverse	Stop
	5	Closing speed	Reduced speed	Full speed
	6	Weight of door leaf < 80 kg	Disabled	Enabled
	7	Weight of door leaf < 60 kg	Disabled	Enabled
	8	Weight of door leaf < 40 kg	Disabled	Enabled

B – Potentiometer Detail – Automatic closing delay time

To prolong automatic closing delay time – Turn potentiometer Clockwise

To reduce the automatic closing delay time – Turn potentiometer Anti clockwise

NOTICE: Potentiometer have a right and left stop point – which must not be overtightened. Adjust potentiometer slightly with an appropriate tool. Damage to control device may result in malfunction.

Quick overview – Wiring wall mounted socket

For detailed operation and programming instructions please consult the separate Evolve Motor and Wiring Fitting Instructions supplied

1. Operation mode semi- automatic / automatic
When semi-automatic mode is set the drive will not close automatically. The potentiometer is without function.
When the automatic mode is set the drive closes automatically.
2. Dead man's control:
When dead man's control is activated the drive will only operate, as long as an input is applied.
Switch 1 is inactive, when dead man's control is selected.
3. Push & go:
With push & go enabled the drive starts to move, as soon as the door leaf is pushed manually.
4. Reaction on obstruction:
When reverse is set the drive stops and starts to move in the opposite direction, as soon as an obstruction is detected.
Otherwise it will stop until a new command is given. This is only possible in semi-automatic mode).
5. Closing speed:
By default the closing speed is slower than the opening speed. The closing speed can be set as fast as the opening speed, by setting this switch to ON>
6. To 8. Maximum door speed
The maximum speed has to be set via these switches.
Maximum speed is dependent on the door leaf weight according to DIN EN 18650.
6: Weight of door leaf up to 80 kg > Maximum speed is 20cm/s
7: Weight of door leaf up to 80 kg > Maximum speed is 23cm/s
8: Weight of door leaf up to 80 kg > Maximum speed is 26cm/s

When no switch is activated, the lowest speed is set (20 cm/s).

When more than one switches are activated, a reduced speed is set (12 cm/s).

Perform Reset

- Switch power supply on.
- ✓ Control device in delivery status or after power cut:
Red LED blinks continuously twice with a short break of 1.5sec.
- Press RESET for about 2 seconds.
- ✓ Red LED blinks continuously.
- Check driving direction of motor with control keys:
When pressing OPEN, door has to open and when pressing CLOSE, door has to close.
→ when driving direction is wrong:
Swap motor cables (terminals MA and MB), check driving direction again.
- Move door in middle position by pressing and holding the control keys.
- Press RESET for about 2 seconds.
- ✓ Red LED lights up permanently,
green LED lights up during motor activity.
- ✓ Door moves in the open position,
Door moves in the closed position,
Door moves in the open position.
- ✓ LED's go out.



Check functionality

- Test, if the door shows desired behavior.
- In case of malfunction check electrical connections and configurations.
→ for electrical connections refer to chapter 5.3 of the Evolve Motor and Wiring Fitting Instructions supplied
→ for configuration refer to chapter 6.1 of the Evolve Motor and Wiring Fitting Instructions supplied
→ Repeat initial operation, if necessary.
- ✓ Initial operation is completed, when function is correct.

1. Secure motor unit to track by inserting block into track and tightening bolts to clamp over bottom of track

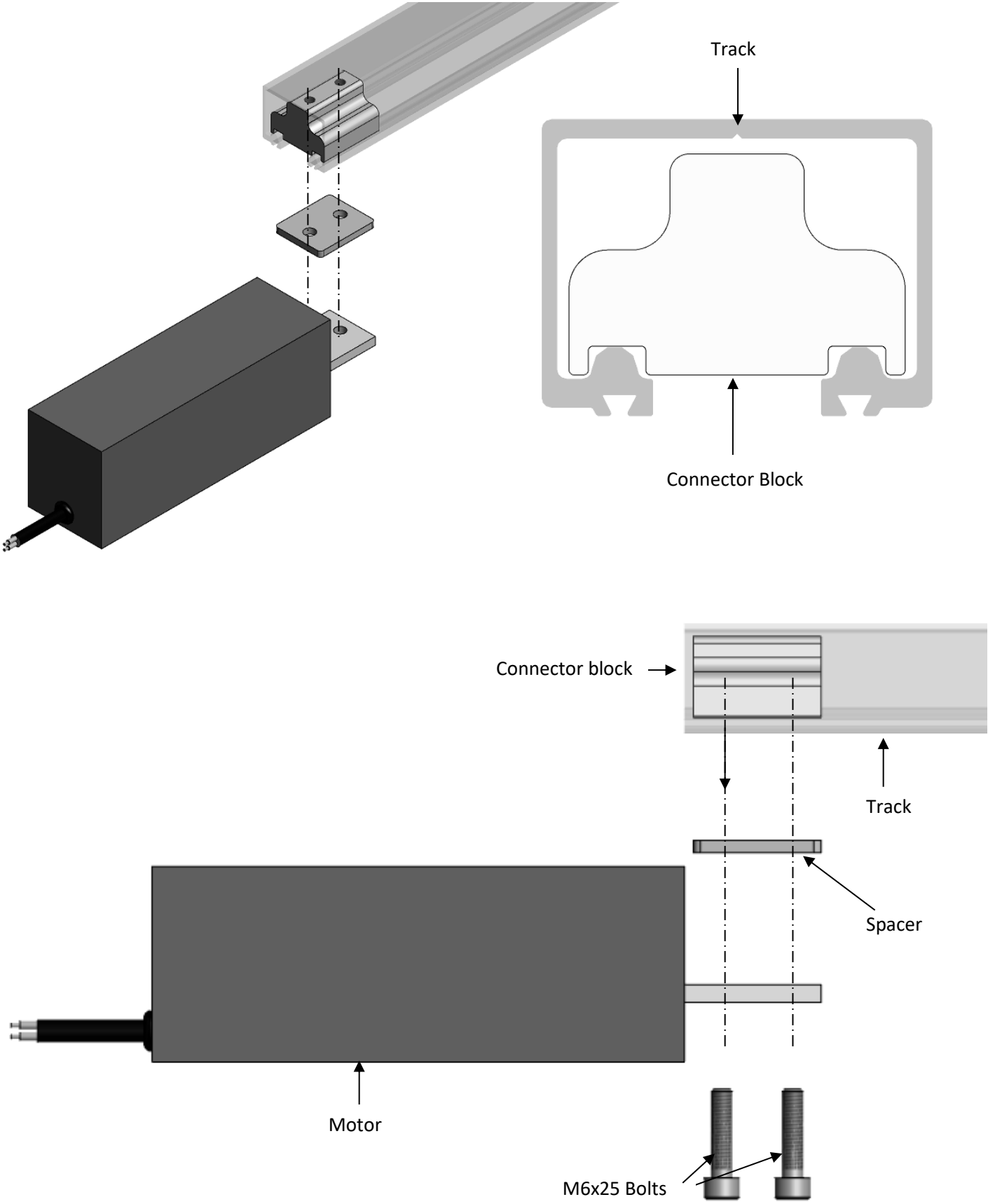

2. Door and hardware preparation (overview)

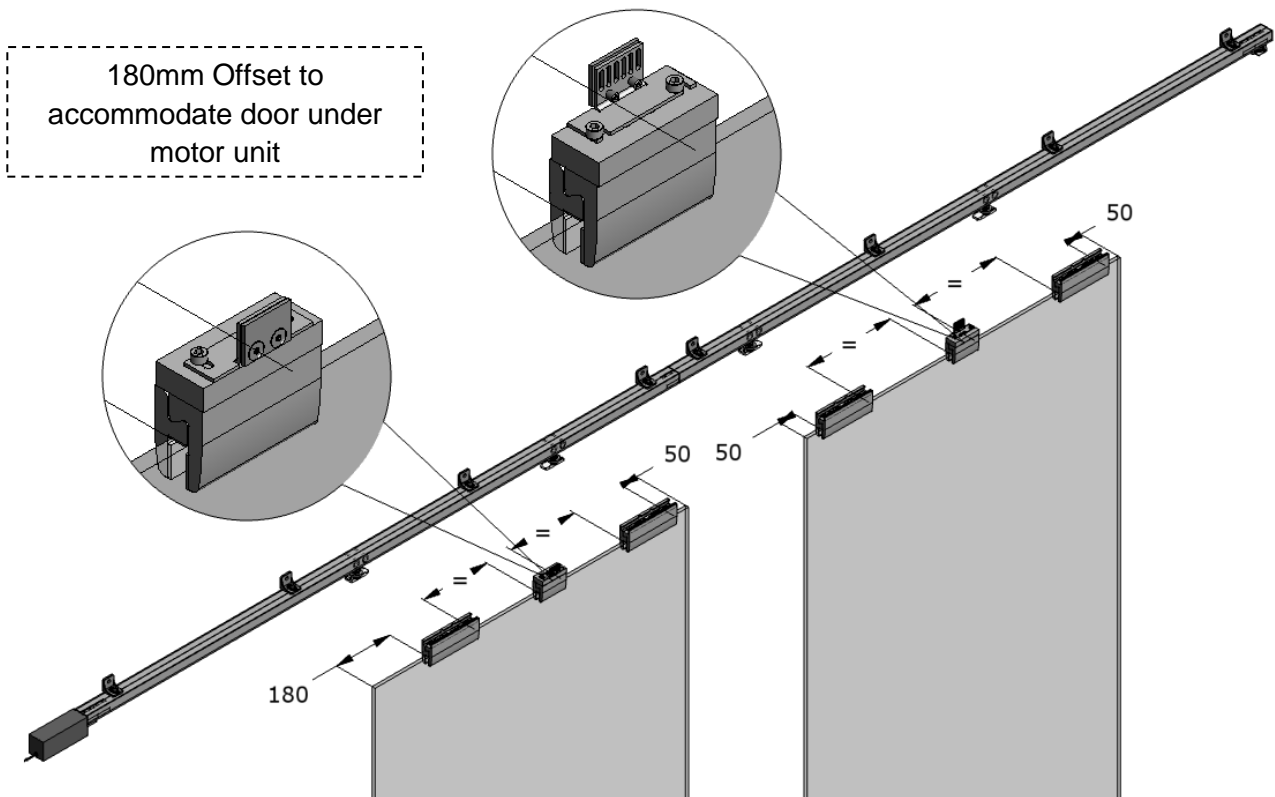

3. Attach glass clamps (Panel positioned under motor highlighted)

- Position first half of glass clamp
- Locate second half of glass clamp over knee of first
- Secure glass clamp with screws

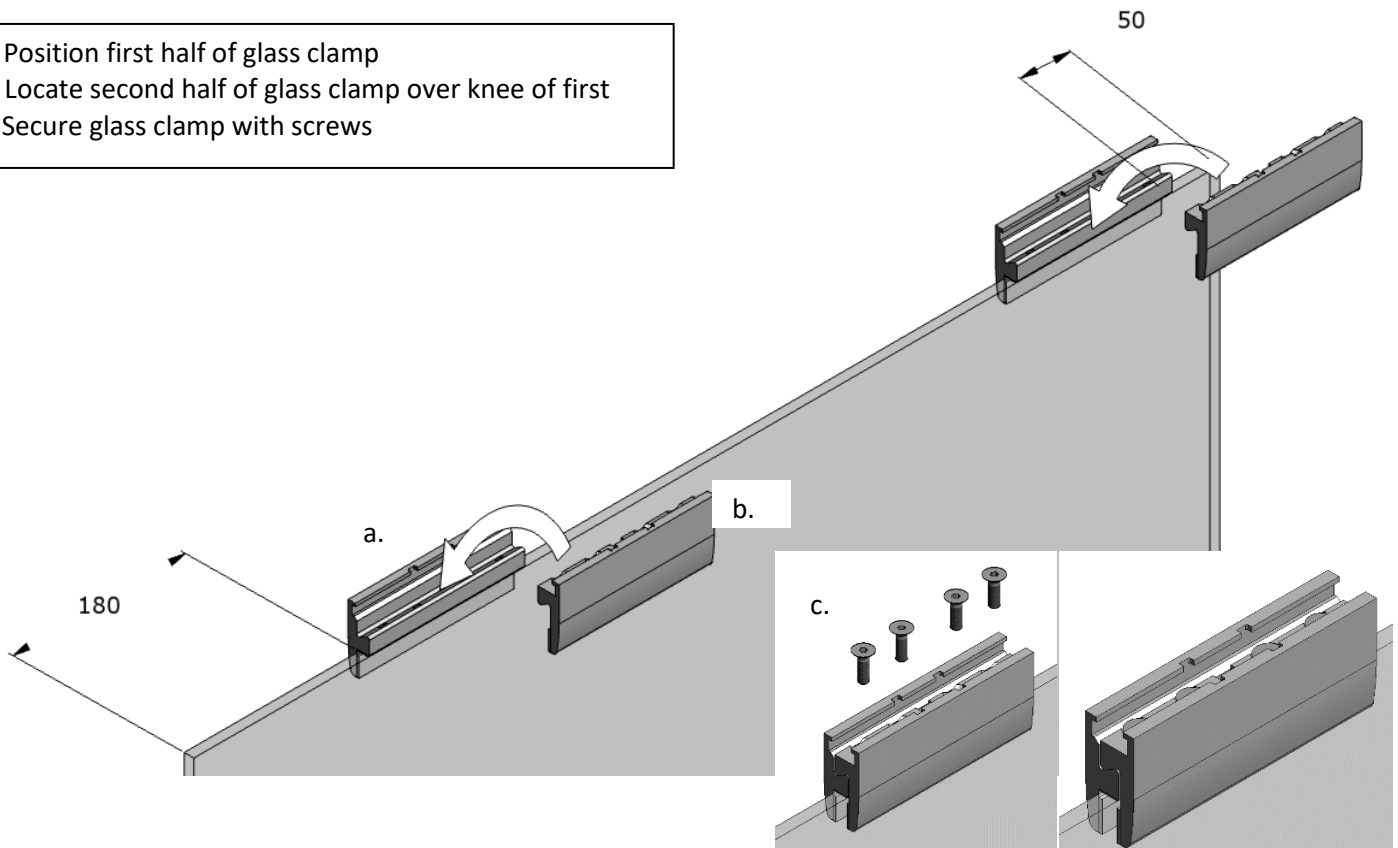

4. Attach belt clamp location clamp centrally (ensure correct belt clamp orientation see panel 2)

- a. Position first half of glass clamp
- b. Locate second half of glass clamp over knee of first
- c. Secure glass clamp with screws
- d. Attach spacer block with screws to top of clamp
- e. Attach belt clamp with screws on to top of spacer

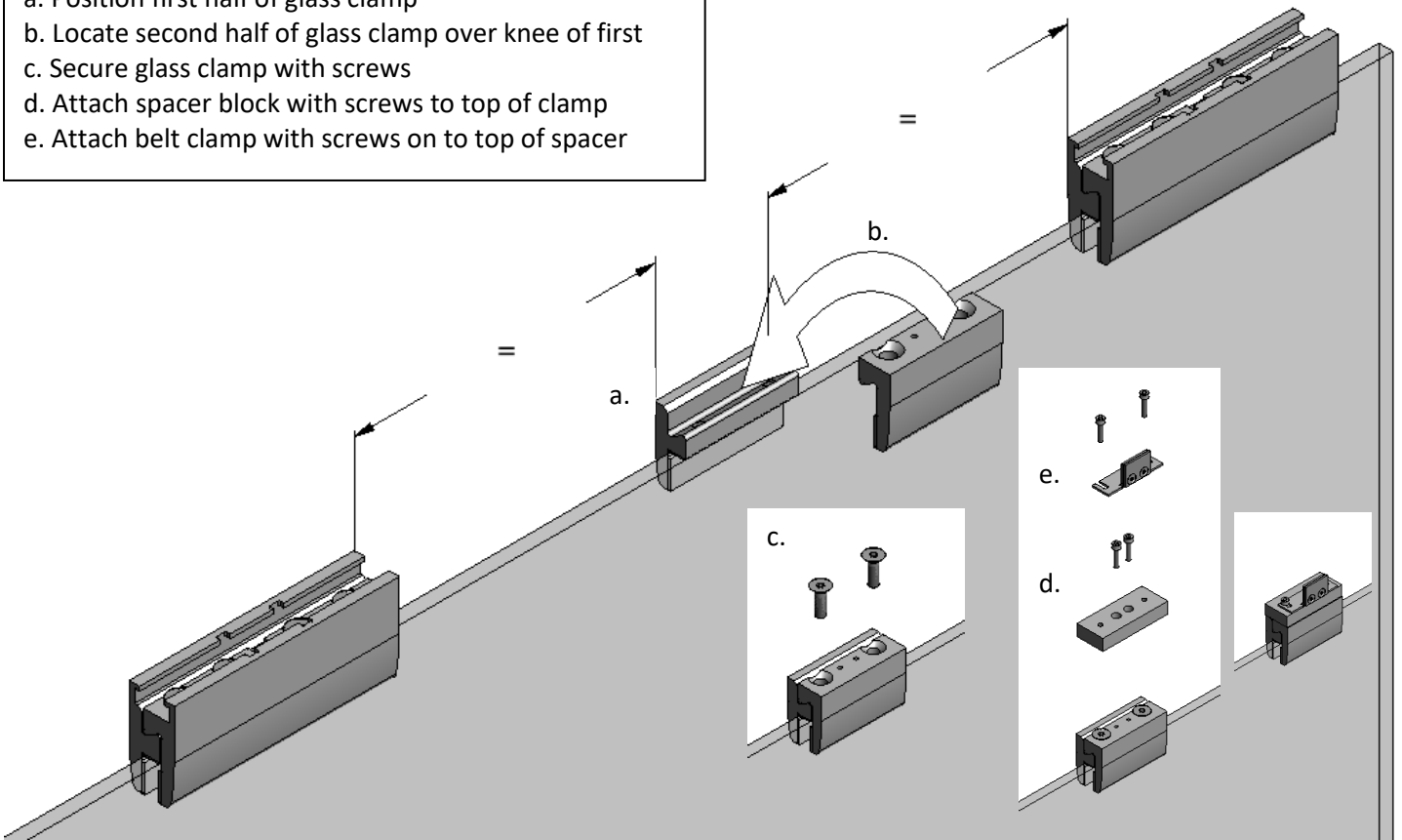

5. Secure track in face fixing installation – spacing between brackets is 600mm MAX (Use suitable wall anchors – NOT PCH)

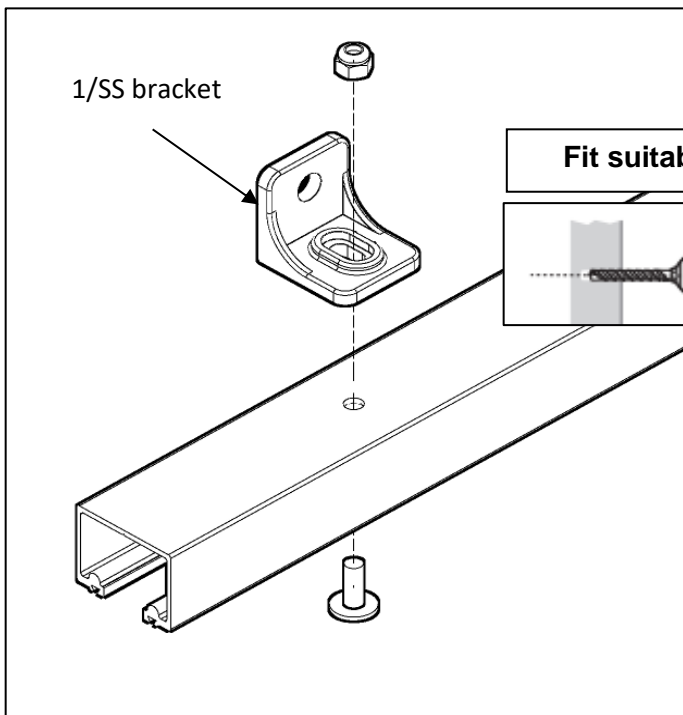

6. Secure track soffit fix installation – spacing between brackets is 600mm MAX (Use suitable wall anchors – NOT PCH)

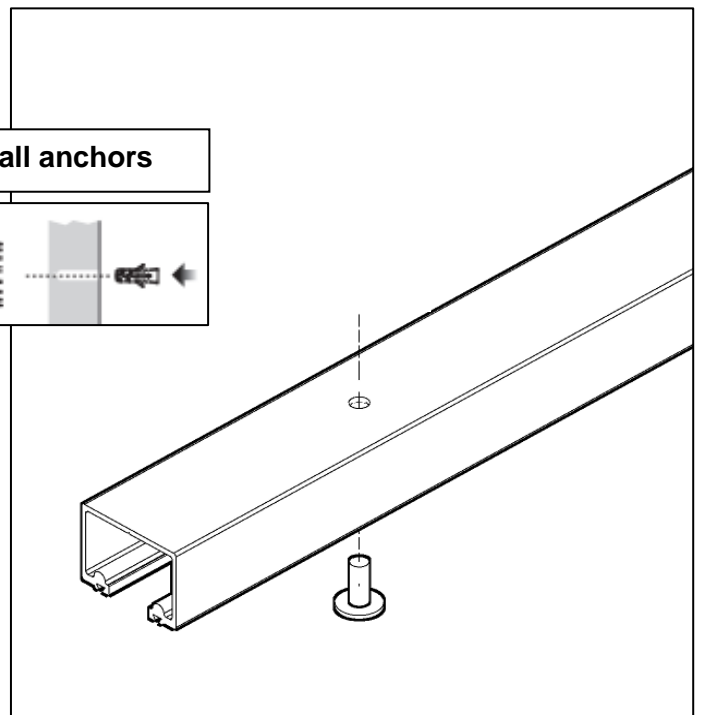

7. Insert track components

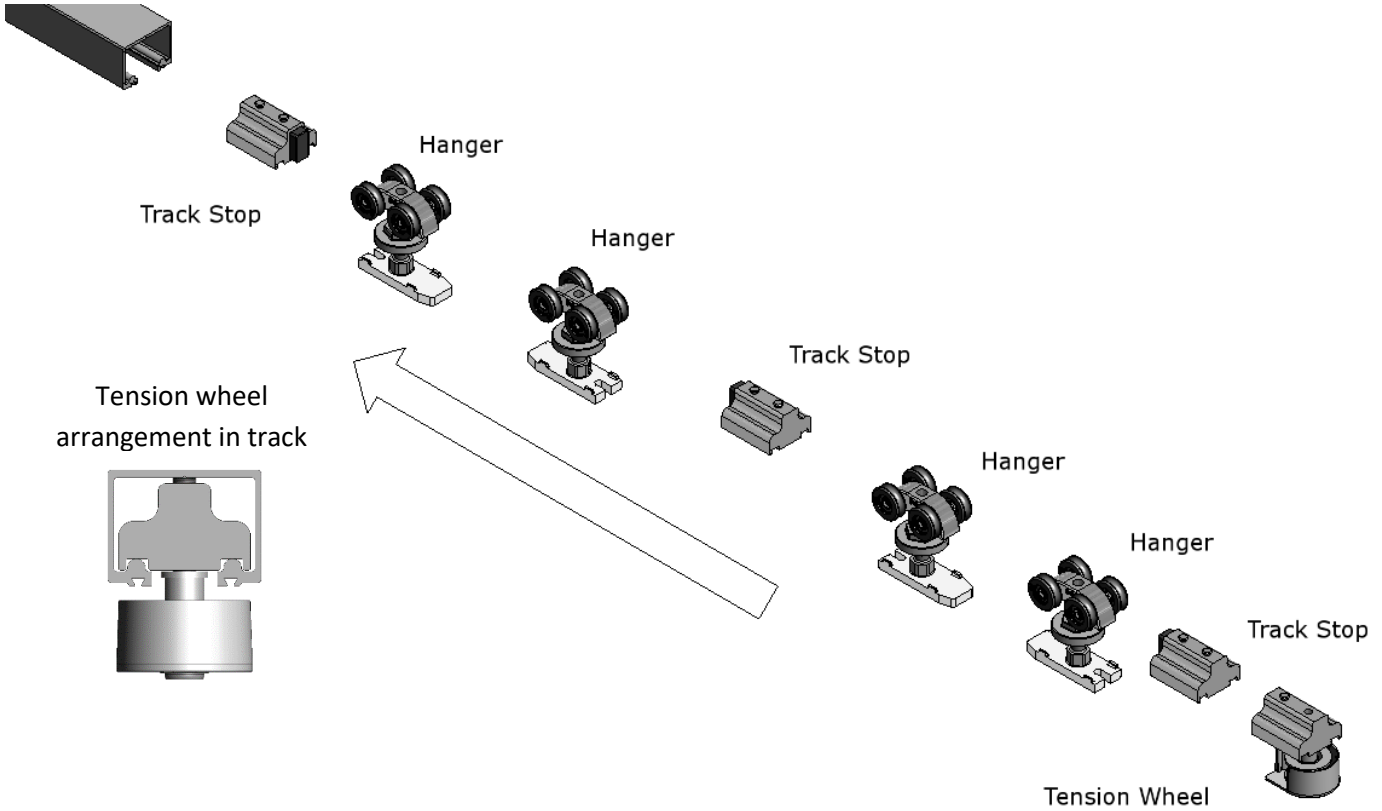

8. Remove covers to allow toothed belt to be attached

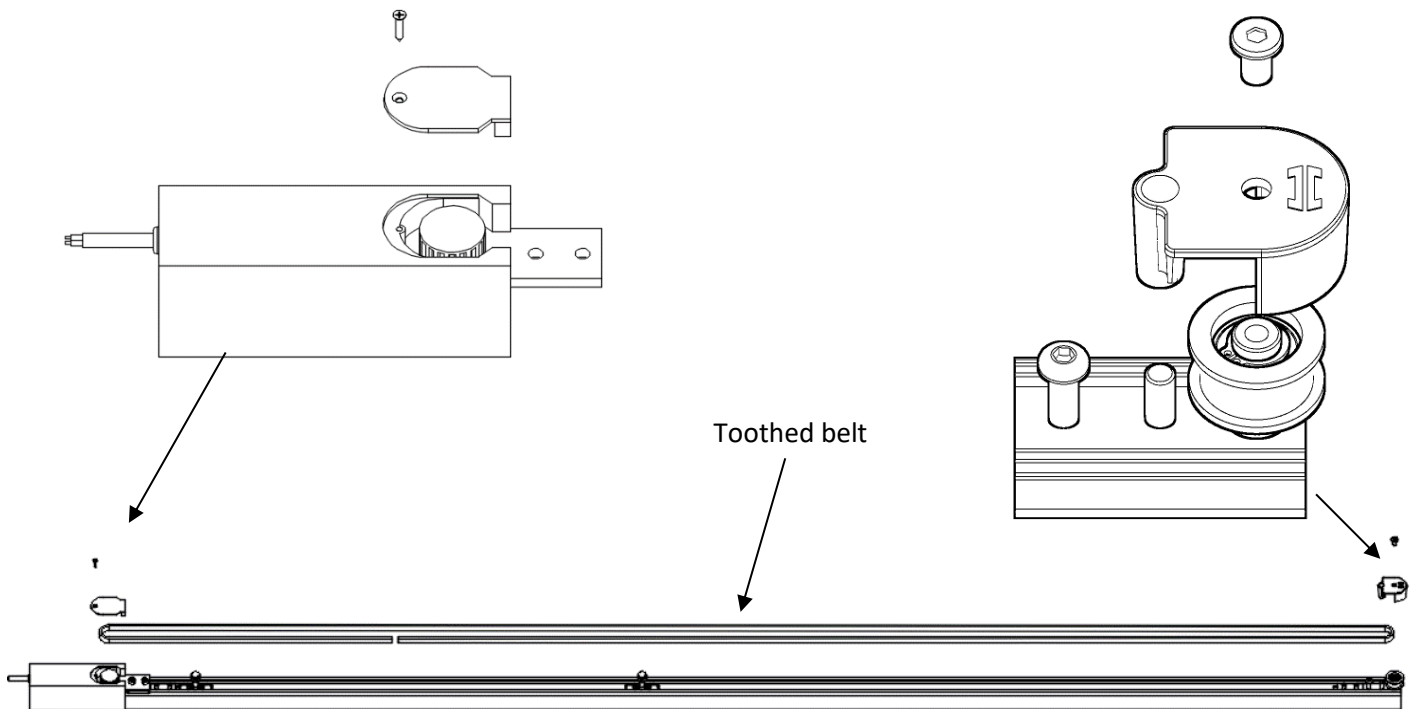

9. Hang glass door

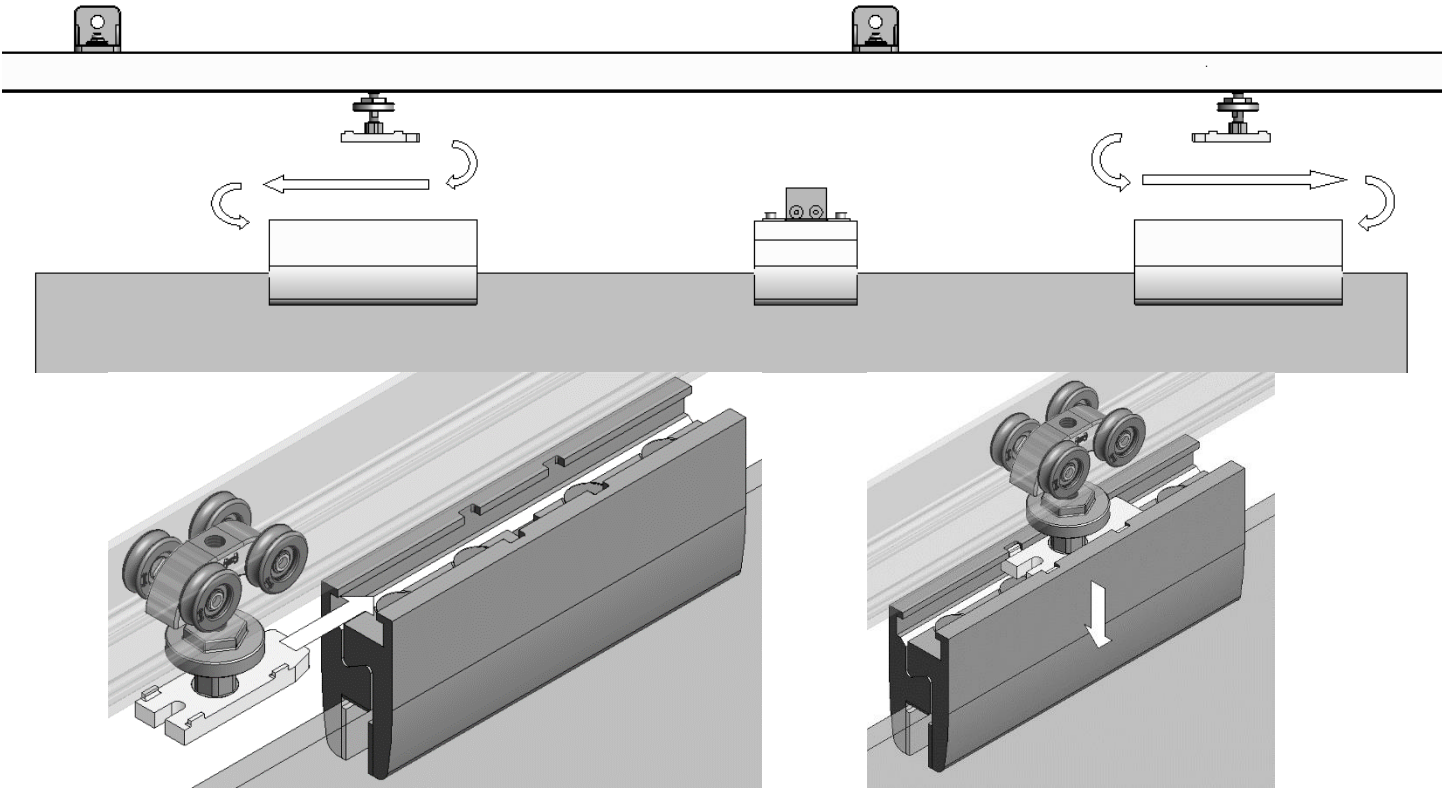

10. Set door height

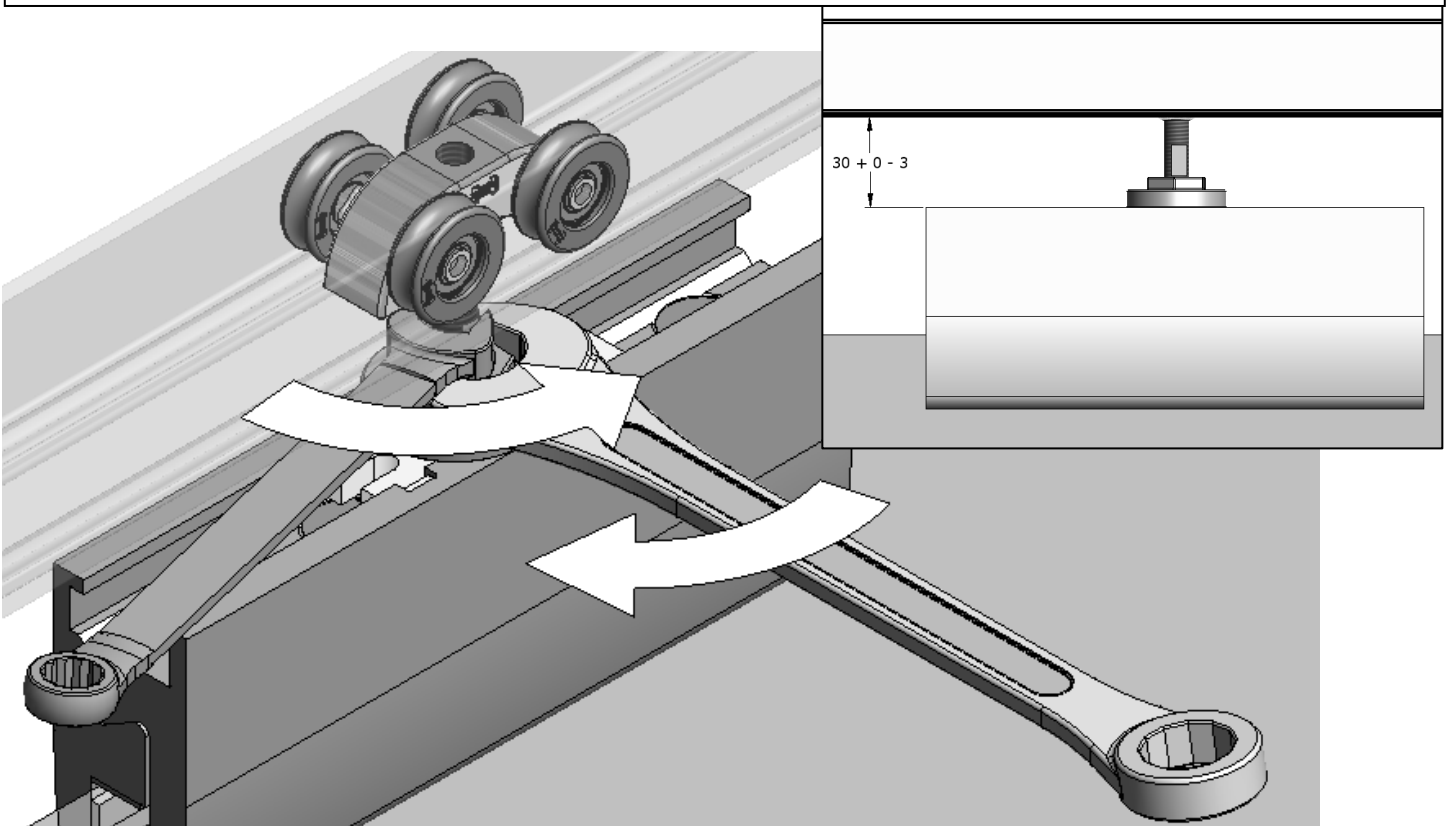

11. Loosen belt clamp – Cut belt to length – Tighten to secure belt

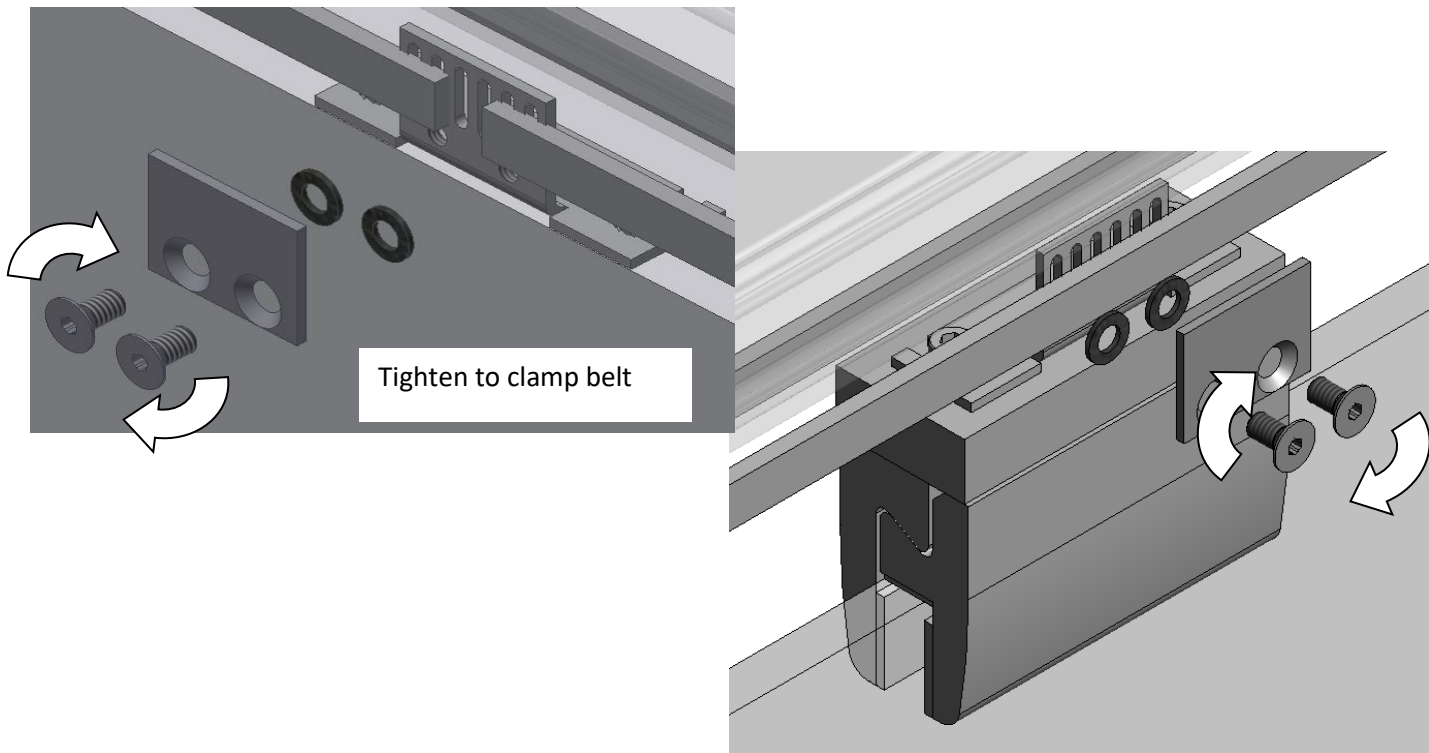

12. Tension toothed belt – Push tension wheel assembly so that the belt is torted and secure assembly in position by tightening the M6 grub screw

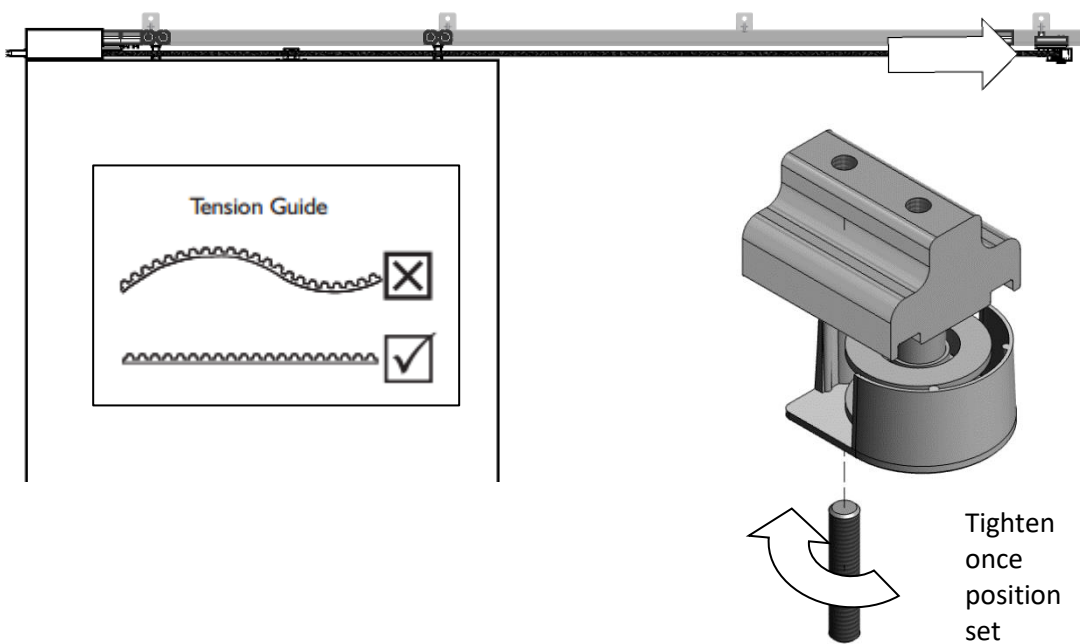

13. Fit Door Guide using spirit level

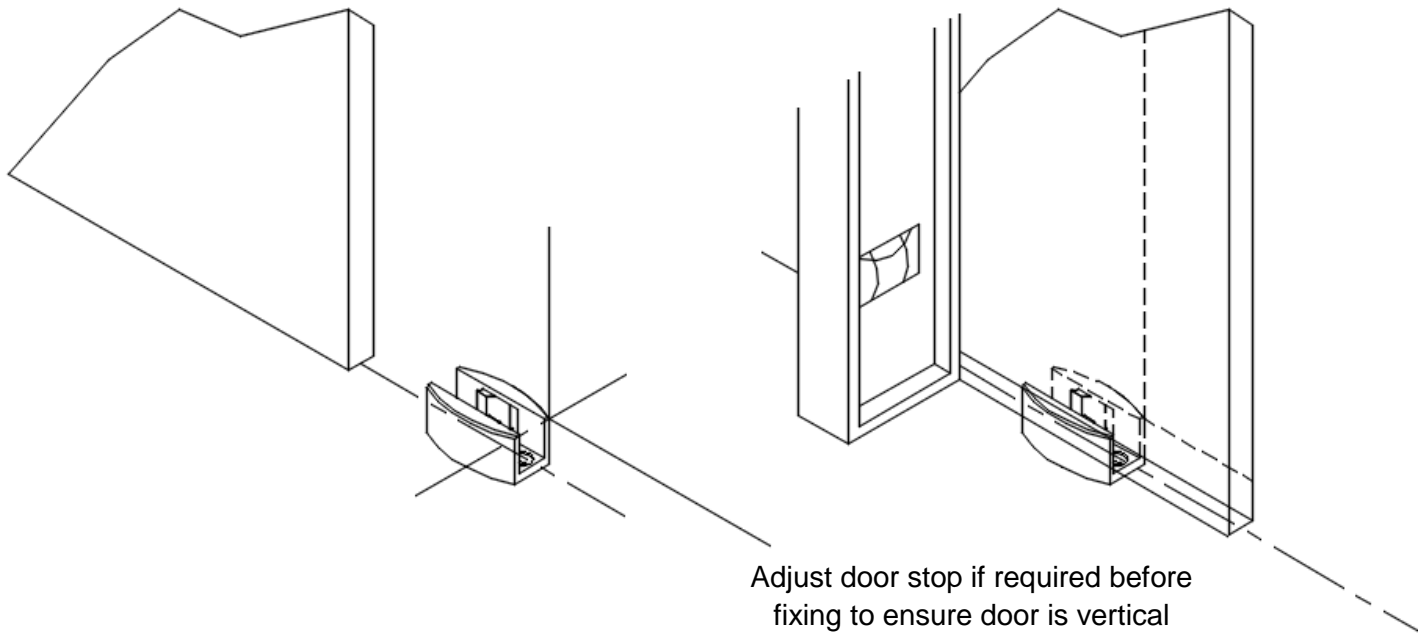

14. Set track stops to limit travel

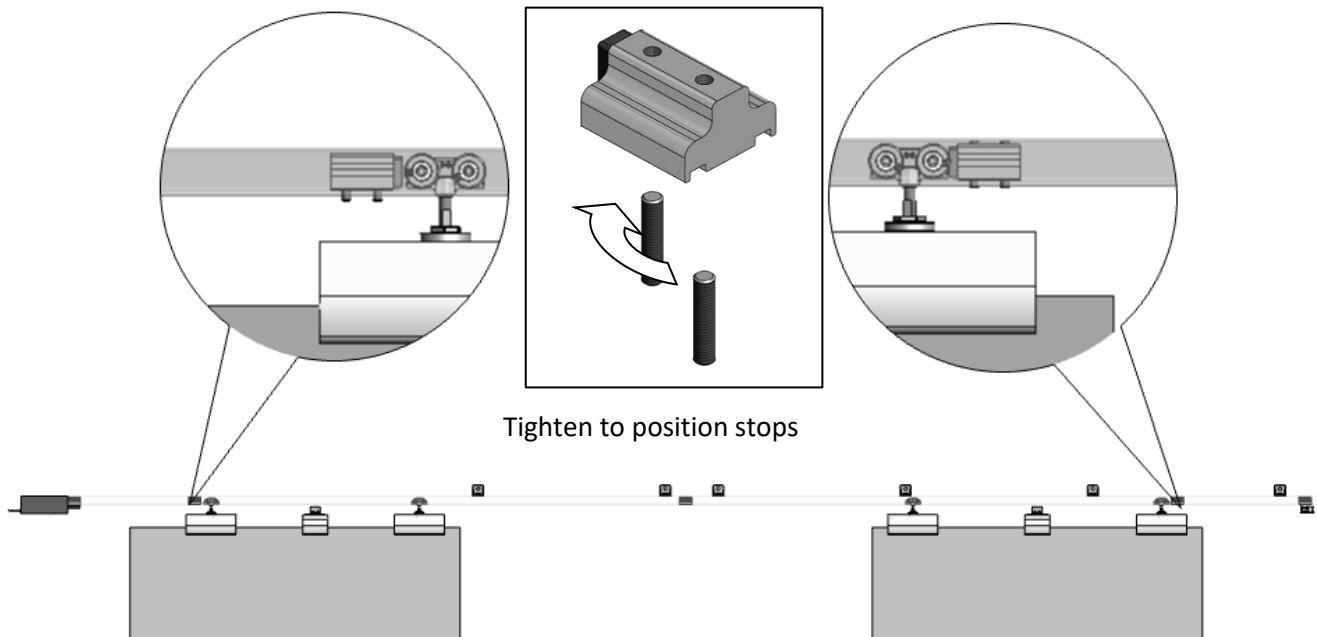

Please Note

The original language of these instructions are English.

The airborne noise of the system under normal operating conditions does not exceed 70dB (A).

General Safety Precautions

This installation is intended for professionally competent personnel only.

Installation, Electrical connections and adjustments must be performed in accordance with Good Working Methods and in compliance with applicable regulations. Before installing the product, carefully read the instructions. Bad Installation could be hazardous.

The packaging material (plastic, polystyrene, etc.) should not be discarded in the environment or left within the reach of children, as these are a potential source of hazard.

Before installing the product, make sure it is in perfect condition.

Do not install the product, make sure it is in perfect condition. Do not install the product in an explosive environment and atmosphere; gas or inflammable fumes are a serious risk hazard. Before installing the system, ensure all structural changes relating to safety clearances and protection or segregation of all areas where there is a risk of being crushed, cut or dragged, and danger areas in general.

Make sure the existing structure is up to standard in terms of strength and stability.

Each installation must clearly show the identification details of the motorized door or gate.

Apply hazard area notices required by applicable regulations.

The electricity supply must be isolated at its source before attempting installation or maintenance.

Disclaimer

PC Henderson nor the motor unit manufacturer take responsibility for failure to use Good Working Methods in building the frames to be motorized or for any deformation occurring during use. PC Henderson and the motor declines all responsibility in the event of component parts being fitted that are not compatible with the safe and correct operation.

For repairs or replacements of products only original spare parts must be used.

Installer responsibility

The installer should provide technical documentation once the installation is complete, this should include.

- EC declaration of conformity with machinery directive
- Installation manual
- Maintenance / Trouble shooting guide (supplied in the drive unit manufacturer operation manual)
- The installer is responsible for affixing final CE mark upon the installation.

Manufacturers Declaration of Incorporation

Manufacturer: PC Henderson Ltd
Durham road
Bowburn
Durham
DH6 5EN
Telephone: 0191 3777345
Fax: 0191 3773166

Hereby declares that the electromechanical automatic door operating system.

Evolve

Evolve Glass

Evolve SIM

Are intended to be incorporated into machinery or to be assembled with other machinery to constitute machinery covered by directive 2006/42/EC

It is in conformity with the provisions of the following directives.

Electromagnetic Directive 2004/108/EC
Low Voltage Directive 2006/95/EC

The technical file is maintained at:

PC Henderson Ltd

Durham road
Bowburn
Durham
DH6 5EN

The authorized representative located within the community is

Fergus Pickard
Product Development Director

PC Henderson Ltd
Durham Road
Bowburn
Durham
DH6 5EN

The above named undertakes to transmit in response to a reasoned request by national authorities, relevant information on the partly completed machinery.

Fergus Pickard, Product Development Director
Bowburn, Durham

Operating Instructions for Evolve Automation Sliding Door System

Release Operation

In the event of malfunction or there is no mains power, move the door manually.

General Safety Precautions

The following precautions are an integral & essential part of the product and must be supplied to the end user. Read them carefully as they contain important indications for the safe installation, use and maintenance. These instructions must be kept and forwarded to all possible future users of the system. This product must be used only for that which it has been expressly designed; any other use is to be considered improper and therefore dangerous.

The manufacturer cannot be held responsible for possible damage caused by improper erroneous or unreasonable use.

Avoid operating in the proximity of moving mechanical parts

Do not enter the field of danger of the motorised door while in motion.

Do not obstruct the motion of the motorised door as this may cause a situation of danger.

Do not lean against or hang on the barrier when it is moving.

Do not allow children to play or stay within the field of action of the motorised door.

Keep remote control or any other control devices out of reach of children, in order to avoid possible involuntary activation of the motorised door.

In the case of breakdown or malfunction of the product, disconnect from the mains, do not attempt to repair or intervene directly & contact only qualified personnel.

Failure to comply with the above may create a situation of danger.

All cleaning maintenance or repair work must be carried out by qualified personnel.

In order to guarantee that the system works efficiently and correctly it is indispensable to comply with the manufacturer's indications thus having a periodic maintenance of motorised door carried out by qualified personnel. In particular regular checks are recommended in order to verify that the safety devices are operating correctly.

All installation, maintenance and repair work must be documented and made available to the end user

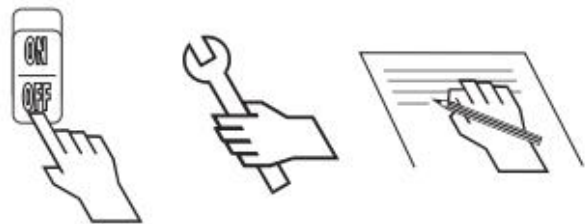
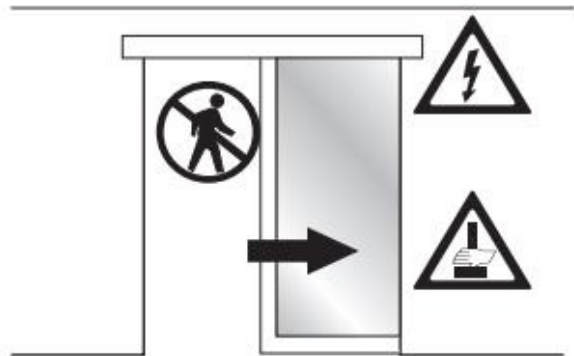
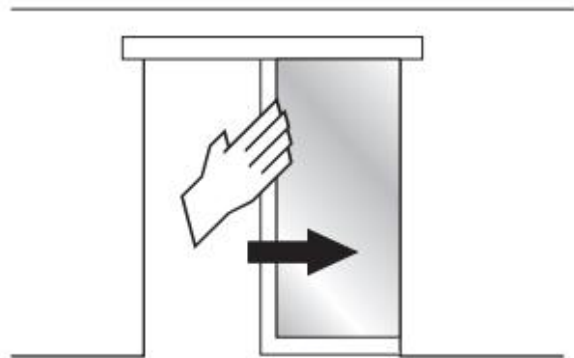

Installer training available upon request, please note this attracts a fee.

Installer

EC Declaration of Conformity – Machinery Directive 200642/CE Schedule II Part 2

Manufacturer:

PC Henderson Ltd

Address:

Durham Road, Bowburn, Durham, DH6 5EN

Name and address of authorized Installer:

Hereby Declare:

Evolve – 80kg

Evolve – SIM Kit

Evolve - Glass

Installation at: (Installation address)

Conforms to Directive:

2006/42/CE – Machinery directive

States that it fulfils the application portion of the following standard

Date & Location of signature:

Signature of the person legally responsibility:

This completed document forms part of the European conformity (CE marking) - to be completed by installer and forwarded to end user.

Must be kept for ten years from installation date.

Markings

Each installation must clearly show the identification details of the motorized door or gate. The installer should apply hazard area notices required by applicable regulations, such as that shown below.

The installer must affix and complete the data tag supplied to the final installation in a suitable prominent position

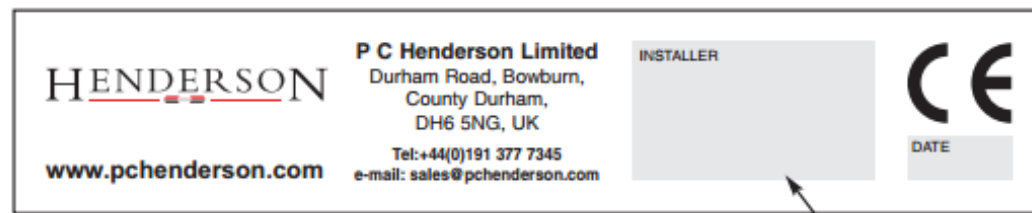

The installer must affix warning signs to the installation on both sides of the door, similar to those shown.



Installer to complete with contact details; Address & telephone number; to be completed with legible and permanent black ink.

Maintenance schedule

Turn off the power

- Clean the moving parts
- Check the belt tension
- Clean the sensors / remote fob (where applicable)
- Check the stability of the automatic system and make sure that all screws/ connections are correctly tightened.
- Check the alignment of the doors and the stop positions

Turn on the power

- Check the stability of the door and that the movement is regular without friction
- Check that all command functions are operating correctly
- Check that the doors developed powers are in accordance with the present standards

Part Description	Part Number	Description of function	Degradation of component factors	Maintenance interval	Planned replacement schedule
Tension wheel assembly	668640	Supports belt movement within machine	Cracking – excessive wear – slipping	From New – Six months – once a year thereafter	Every 10 Years of service*
Wheel cover	668323	Moving part protective cover	Cracking – excessive wear – slipping	From New – Six months – once a year thereafter	#
Toothed belt	668605	Provides movement to doors within system	Fraying / Shearing – elongation – discoloration	From New – Six months – once a year thereafter	Every 2 years*
Motor unit	668600	Provides movement to doors within system	Repeated error messages – failure of machine	From New – Six months – once a year thereafter	#
Hanger	220503	Door is suspended from hanger	Black deposits within track / on top of door	From New – Six months – once a year thereafter	#

*= Or sooner dependent upon operating conditions.

= Replacement only recommended when apparent excessive wear affects the performance of the installation

Proof book

This proof book contains technical references and records of installation, maintenance, repair and alterations carried out must be made available for any inspection by authorized bodies. This book should be completed by the installer and forwarded to the end user.

Specification of the Motorized door and installation

Customer:

Order Number:

Model & Description:

Dimension and Weight:

Location:

List of Components Installed

Motor/ Drive Unit:

Switch:

Remote fob:

Motion detector:

Sign off Check Sheet:

Declaration of conformity filled out

Henderson & the motor unit manufacturer

Proof book filled out

Fitting instructions

CE Label completed & installed in suitable location

All documents left with end user

Warning signs installed in suitable locations

Signature of receipt

Warning of residual risks and of foreseeable improper use

Inform the end user of risk points regarding risk and foreseeable improper risks.

Proof book

Description of the work

<input type="checkbox"/>	Installation	Details:
<input type="checkbox"/>	Start Up	_____
<input type="checkbox"/>	Adjustments	_____
<input type="checkbox"/>	Maintenance	_____
<input type="checkbox"/>	Repairs	_____
<input type="checkbox"/>	Alterations	

<input type="checkbox"/>	Installation	Details:
<input type="checkbox"/>	Start Up	_____
<input type="checkbox"/>	Adjustments	_____
<input type="checkbox"/>	Maintenance	_____
<input type="checkbox"/>	Repairs	_____
<input type="checkbox"/>	Alterations	

<input type="checkbox"/>	Installation	Details:
<input type="checkbox"/>	Start Up	_____
<input type="checkbox"/>	Adjustments	_____
<input type="checkbox"/>	Maintenance	_____
<input type="checkbox"/>	Repairs	_____
<input type="checkbox"/>	Alterations	

<input type="checkbox"/>	Installation	Details:
<input type="checkbox"/>	Start Up	_____
<input type="checkbox"/>	Adjustments	_____
<input type="checkbox"/>	Maintenance	_____
<input type="checkbox"/>	Repairs	_____
<input type="checkbox"/>	Alterations	

<input type="checkbox"/>	Installation	Details:
<input type="checkbox"/>	Start Up	_____
<input type="checkbox"/>	Adjustments	_____
<input type="checkbox"/>	Maintenance	_____
<input type="checkbox"/>	Repairs	_____
<input type="checkbox"/>	Alterations	