



# Trailer Tech



## ULTIMATE TRADIE PACK

PROVIDING THE BEST TRADESMAN TRAILER PACKAGE ON THE MARKET

# TABLE OF CONTENTS

**1** KEY SPECIFICATIONS

**2** KEY FEATURES

**3** KEY FEATURES

**4** FULL SPECS & FEATURES

**5** ADDITIONAL UPGRADES

**6** RANGE OF PHOTOS

**7** RANGE OF PHOTOS

**8** OUR MISSION & VISION

**9** ABOUT US

**10** CONTACT US

# KEY SPECIFICATIONS

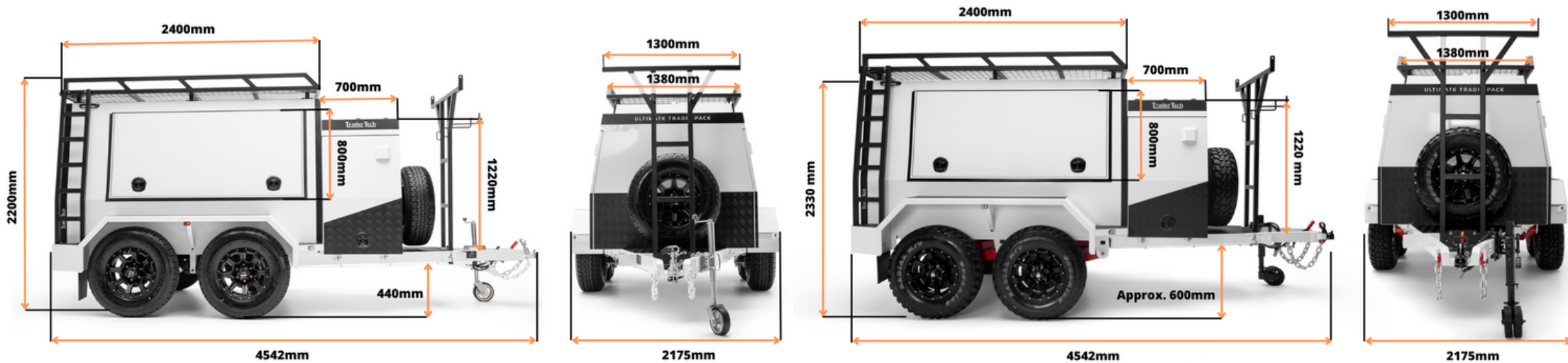

## DUAL SOLID AXLE

1500kg TARE- 3200kg ATM  
 8 x 5 Dual Solid Axle Model  
 5-Year Structural Warranty  
 1-Year Parts Warranty  
 50mm Solid Axles

12-inch Electric Drum Brakes All Around  
 LT 265/75R16 All Terrain Tires on Black Alloy  
 Wheels Fitted to Landcruiser 6-Stud Hubs

## INDEPENDENT SUSPENSION

1600kg TARE - 3200kg ATM  
 8 x 5 Dual Axle Independent Suspension  
 5-Year Structural Warranty  
 1-Year Parts Warranty  
 50mm Solid Axles

12-inch Electric Drum Brakes All Around  
 LT 265/75R16 Mud Terrain Tires on Black  
 Alloy Wheels Fitted to Landcruiser 6-Stud Hubs  
 with Mud Terrain Tyres

# KEY FEATURES



**DOUBLE GPO'S, USB CHARGER & 12V CHARGER**



**16" ALLOYS 265/75R 16 LT FITTED TO LANDCRUISER 6 BOLT HUBS**



**HUGE 90L WATER TANK ON A HIGH PRESSURE 12V TAP**



**TWO 80W (Pmax) 12V SOLAR PANELS MOUNTED ON SLIDES**



**INDEPENDENT SUSPENSION MODEL UPGRADE AVAILABLE**



**FULL CENTRAL LOCKING KIT & VIPER ALARM SYSTEM**

# KEY FEATURES

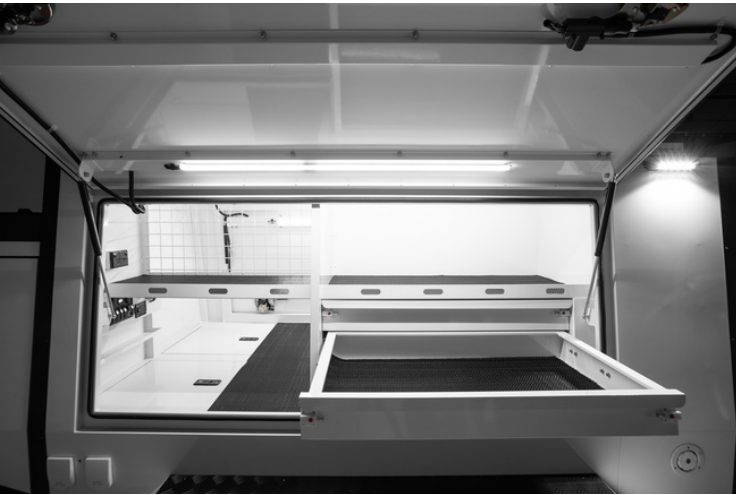

**HUGE AMOUNTS OF STORAGE & TOOL BOXES THROUGHOUT**



**2x 1800mm LONG REAR TRUNDLE DRAWERS 300mm DEEP**

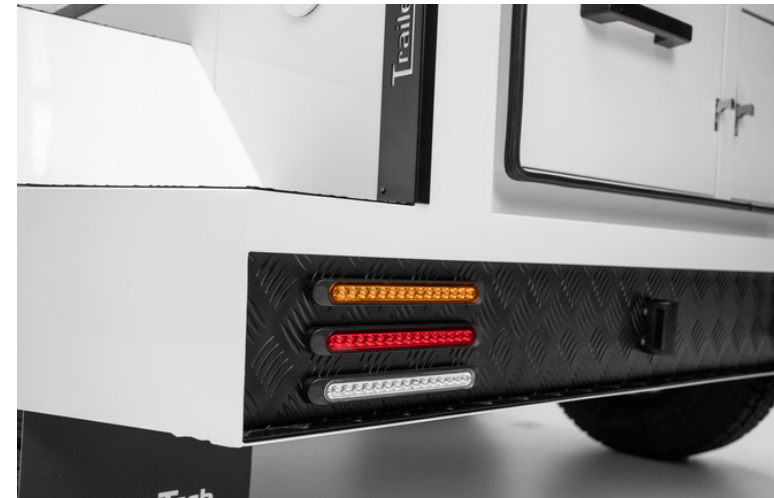

**ALL STANDARD SAFETY AND RUNNING LIGHTS**



**TWO 100AH AGM BATTERIES & 2000W SMART INVERTER**



**CUSTOM UNIQUE AUSTRALIAN ENGINEERED DRAWBAR**



**FULL LED LIGHTING INSIDE AND OUTSIDE**

# FULL STANDARD SPECS & FEATURES

**DUAL AXLE - TARE:** 1500 KG **GVM:** 3200 KG **PAYLOAD:** 1700 KG  
**IS MODEL - TARE:** 1600 KG **GVM:** 3200 KG **PAYLOAD:** 1600 KG

**TOTAL SIZE:** L 4500mm x W 2185mm x H 2175mm  
[INDEPENDENT SUSPENSION: H 2400mm]

- 2450 MM X 1500 MM (8 FT X 5 FT) **MAIN SECTION**
- 100MM X 50MM X 4MM **RHS HOT DIPPED GAL**
- **GALVANISED PRIMARY BODY** W/CNC CUT PANELING, FRAMING, AND FIXTURES
- **POWDER-COATED** INSIDE AND OUT - COLOURS AVAIL IN GLOSS OR MATTE FINISH
- FRONT TOOLBOX WITH **FRIDGE SLIDE** AND **SHELVES**
- **DRAWERS** AND **SHELVES** FITTED IN THE PASSENGER SIDE OF THE CENTRAL SECTION
- TWO DEEP TRUNDLE DRAWERS AT THE REAR – **1800MM LONG DRAWS**
- **FOUR SHELVES** FITTED IN THE REAR OF THE TRAILER
- **HEAVY-DUTY** DRAWER HARDWARE THROUGHOUT
- HEAVY-DUTY **ROOF RACK** WITH **REAR ROLLER** FOR ASSISTING WITH HEAVY LIFTS
- BUILT-IN **LADDER** FOR ACCESSING ROOF RACK
- REMOVABLE **1300MM WIDE ROOF RACK SUPPORT** AT THE FRONT FOR LONG LENGTHS
- HEAVY-DUTY **8-LEAF SPRINGS** WITH ROLLER ROCKER
- **50MM SOLID AXLES** WITH 12-INCH DRUM BRAKES – WHEELS BRAKED INDIVIDUALLY
- 16" 6 STUD **LANDCRUISER ALLOY WHEELS** - INCLUDING A MATCHING SPARE TYRE SIZE: 265/75R16
- HEAVY-DUTY T-HANDLES THROUGHOUT - ALL KEYED ALIKE - **CENTRAL LOCKING KIT**
- **SLIMLINE L.E.D.** TAILLIGHTS - A DISTINCTIVE AND UNIQUE DESIGN
- **DUAL BATTERY SYSTEM** – 2X 100AH AGM DEEP CYCLE BATTERIES
- 2000-WATT PURE SINE WAVE **INVERTER** WITH **BUILT-IN CHARGER**
- **TWO 80W (P-MAX)** 12V **SOLAR PANELS** INSTALLED ON A DRAWER SYSTEM ON THE ROOF
- EXTERNAL **15 AMP 240-VOLT** PLUG-IN FOR CHARGING FROM MAINS POWER
- EXTERNAL **240-VOLT POWERPOINT** FOR RUNNING EXTENSION LEADS AROUND THE JOB SITE
- INTERNAL **240-VOLT DOUBLE POWERPOINT** FOR CHARGING DEVICES AND BATTERIES
- FULL CENTRAL LOCKING KIT ON ALL 8 LOCKS – INCL **ALARM SYSTEM**
- **L.E.D. LIGHTING** INSTALLED INTERNALLY AND EXTERNALLY
- **FULL SWITCHBOARD** WITH A VOLTMETER, USB, 12 VOLT, AND SWITCHES
- 90-LITER FRESH **WATER TANK** WITH 12-VOLT WATER PUMP & **TAP FITTED**







# TO SUPPORT OUR AUSSIE TRADIES, ONE TRAILER AT A TIME

NO MATTER THE SIZE OF THE JOB, THE LOCATION, THE TRADE OR THE TOOLS  
TRAILERTECH IS HERE TO HELP GET THE JOB DONE EVERY TIME.



## ABOUT US



Here at TrailerTech we pride ourselves on the quality of our products and stand by our rating as Australia's #1 Trailer and Cabin manufacturer. For us functionality and affordability is everything. As a result we have spent countless hours designing and engineering our unique Trailers and Cabins in order to make them the most sought after on the market.

Beginning production in 2010, a family business, TrailerTech specialises in custom built trailers and cabins. We continue to expand our line of products and endeavour to meet the diverse needs of our customers whether that be in mining, civil engineering, farming, construction or recreational use.

Our products are not limited to just Trailers and Cabins, in fact we host a range of smaller farm and construction supplies including our popular electric fence energisers and various mining equipment.



# CONTACT US

## TRAILERTECH HQ

17 Telford Place, Arundel QLD 4214

## OUR ULTIMATE TRADIE PACK DISTRIBUTORS



NSW DISTRIBUTOR

17 Orielson Rd, Smeaton Grange NSW 2567

## EMAIL ADDRESS

[sales@trailertechau.com.au](mailto:sales@trailertechau.com.au)

## PHONE NUMBER

(07) 5528 8858



## WEBSITE

[www.trailertechau.com.au](http://www.trailertechau.com.au)

## SOCIAL MEDIA

[www.instagram.com/TrailerTechAU](http://www.instagram.com/TrailerTechAU)

[www.facebook.com/TrailerTechAU](http://www.facebook.com/TrailerTechAU)

[www.youtube.com/TrailerTech](http://www.youtube.com/TrailerTech)