

SYDNEY WOOD HEATER CLEARANCE CENTRE

PROUDLY
AUSTRALIAN MADE

SUPREME SERIES



ULTIMATE SUPREME 17

This inbuilt woodheater is ideal for the medium sized home. If an open fireplace already exists, this heater will easily slide in to create an efficient and attractive alternative. It features an extra large viewing area, a three speed fan and has a heating capacity of 120 - 230 square metres. This firebox can hold logs up to 450mm in length.

FACTORY DIRECT **PRICE**

AVAILABLE FINISHES



CHAMPAGNE



MARCASITE



GUNMETAL

INSTALLATION

The Ultimate Collection has been designed for easy installation which should be performed by a qualified installer. Ultimate freestanding models can also be installed without the expense of a permanent hearth (see hearth requirements). Inbuilt models are designed to integrate with existing masonry fireplaces of standard dimensions without the need for structural modifications.

HEARTH REQUIREMENTS

The base of the heater may form an integral part of the hearth with the addition of an extension (as illustrated) and can be constructed from heat resistant materials. It should be fixed to conform with the requirements of Australian Standard AS 2918 - 1990 Section 3.3.2.

FLUE REQUIREMENTS

The flue kit should be installed strictly in accordance with Australian Standard AS 2918 - 1990. Thermal testing of the units was carried out using a Western Valley Pty. Ltd. Valley single flue kit. Installation is not restricted to the use of the above brand of flue kit, but any flue kit used must have been tested to conform with the requirements of Australian Standard AS 2918 - 1990 with the unit.

TRIPLE BURN SYSTEM

Primary air is drawn into the firebox through the airports above the door, it washes downover the glass door into the fuel at the bottom of the firebox creating primary ignition. The combustible gases rise to the baffle plate where secondary air is injected into the firebox, igniting those gases and creating secondary combustion. Any Unburnt gases are then drawn over the ceramic glow plug where tertiary air is introduced to complete the final stage of our Triple Burn System.

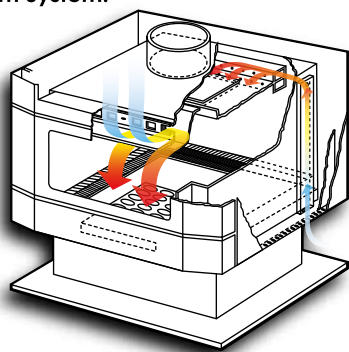

TYPICAL INSTALLATION

EXAMPLE INTERNAL INSTALLATION

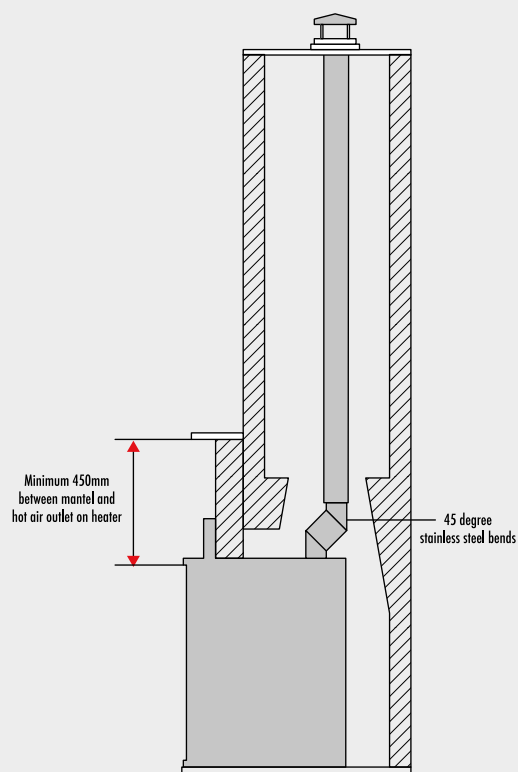

HEATER DIMENSIONS

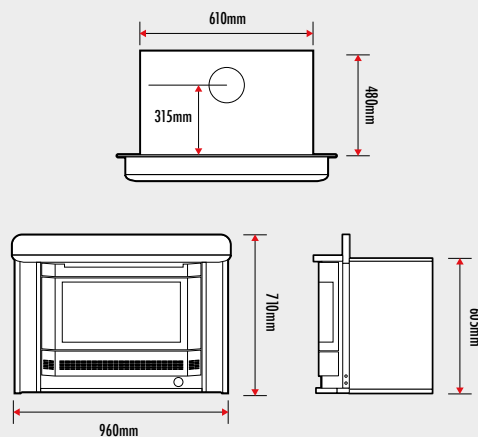

	HEIGHT	DEPTH	WIDTH	WEIGHT	FRONT FASCIA TO CENTRE FLUE
REAR CASING	605mm	480mm	610mm	175kg	315mm
FASCIA	710mm		960mm		

A slight reduction in performance may result through high ceilings, large glass areas, lack of insulation or drafts. Ultimate distribution reserves the right to alter specifications without notice. Photos are for illustrative purposes only. Colours may vary due to the printing process.

SYDNEY WOOD HEATER CLEARANCE CENTRE