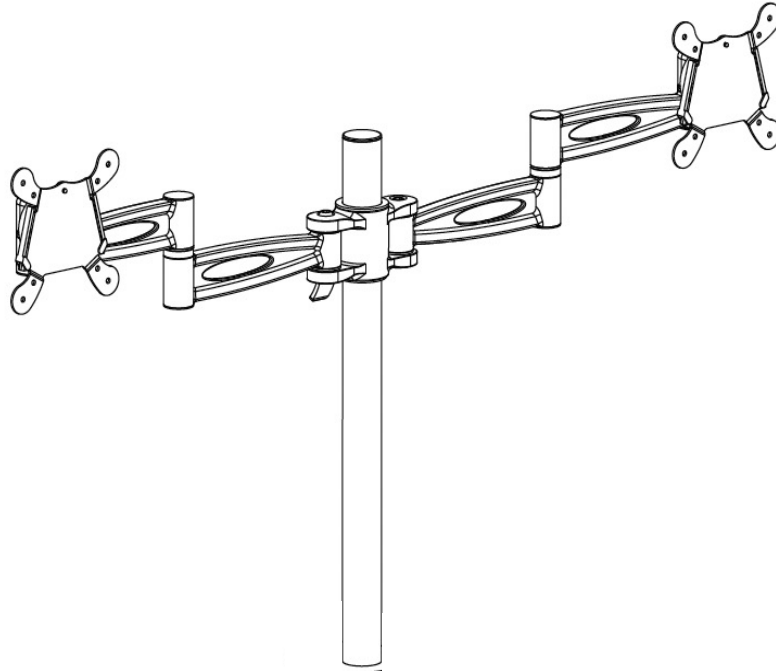


Dual Monitor Arm Manual



Dual Monitor Arm accessory for:

Lillipad 42

Lillipad 48

Maximum Load: 2 x 12lbs (2 x 5.4kg)

Screen Size Capacity: 2 x 27"

VESA Plate Compatible

Unpacking Instructions

Carefully open the carton, remove contents and lay out on cardboard or other protective surface to avoid damage.

Check package contents against the Parts List in the next page to ensure that all components were received. Do not use damaged or defective parts.

Carefully read all instructions before attempting installation.

DÉBALLAGE

Ouvrir le carton d'emballage avec précaution, sortir le contenu et le disposer sur le carton ou sur un autre support afin de ne pas l'endommager.

Vérifier le contenu du paquet avec la liste des composants sur la page 2, afin de s'assurer qu'il ne manque rien. Ne pas utiliser des composants abîmés ou défectueux.

Lire soigneusement la notice avant toute tentative d'installation.

IMPORTANT SAFETY INSTRUCTIONS



WARNING- RISK OF SERIOUS OR FATAL CRUSHING INJURIES.

Do not install or operate before reading all instructions.

CAUTION: Choking Hazard- This product contains small parts that could be a choking hazard if swallowed. Keep these items away from children.

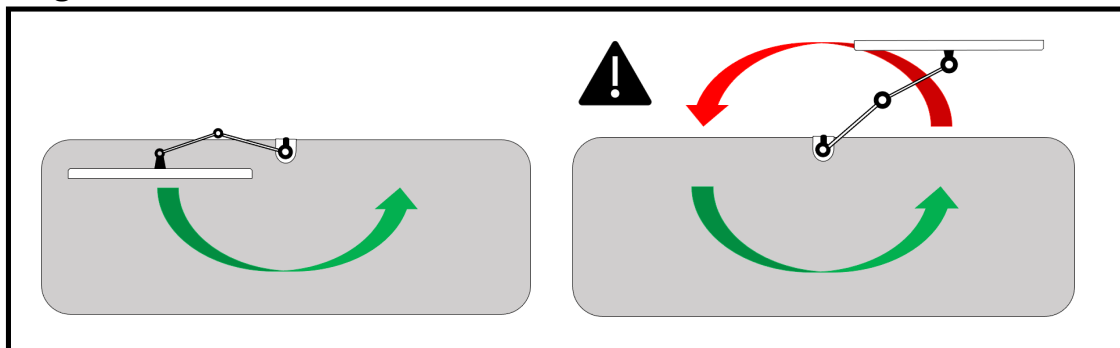
1. Do not allow children to play on or near this furnishing
2. Check mounting screws frequently to ensure they are not loose.
3. For indoor use only



WARNING- RISK OF TIP OVER. SERIOUS INJURY, DEATH, OR PROPERTY DAMAGE MAY OCCUR!

1. For use with displays weighing 12lbs (5.4kg) or less. Use with heavier displays may result in instability causing tip over resulting in death or serious injury.
2. Do not extend display past edge of desktop. Figure A
3. Detach monitor before removing arm from mounting pole.


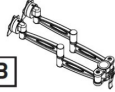










Figure A



SAVE THESE INSTRUCTIONS

Parts List

Liste des Composants

Item Article	Description Description	Quantity Quantité'	Item Article	Description Description	Quantity Quantité'
	Pole * Poteau *	1		Swivel arm Bras de moniteur pivotant	1
	VESA plate Plaque de support VESA	1		M4 spacer Bague entretoise M4	4
	M4 washer Rondelle M4	5		M4 x 12 screw Vis M4 x 12	4
	M4 x 6 screw Vis M4 x 6	1		Allen key Clé allen	1
	Cable management clips Pince pour le passage des câbles	2		M4 x 30 screw Vis M4 x 30	4
	10-32 x 1/2" Screw * Vis 10-32 x 1/2" *	2		Pole Clip* Clip de poteau *	1

* Pole (A) and Clip (K/L) may be pre-installed on desk.

* Le poteau (A) et le clip (K/L) peuvent être préinstallés sur le bureau

Tools Required:
Phillips Screwdriver

Outils Necessaries:
Tournevis Philipps

Important Safety Information

INFORMATIONS IMPORTANTES DE SÉCURITÉ

Install and operate this device with care. Please read these instructions installation, and carefully follow all instructions contained herein.

Installer et manipuler cet appareil avec soin. Avant toute installation, veuillez lire attentivement cette notice et bien suivre toutes les instructions contenues.

Please visit www.Lillipad.com/support for help if you don't understand these directions or have any doubts about the installation of this product.

Si vous ne comprenez pas cette notice ou si vous avez des doutes quant à l'installation du produit, veuillez visiter www.Lillipad.com/support.

Do not use this product for any purpose or in any configuration not explicitly specified in this instruction. We hereby disclaim any liability for injury or damage arising from incorrect assembly, incorrect mounting, or incorrect use of this product.

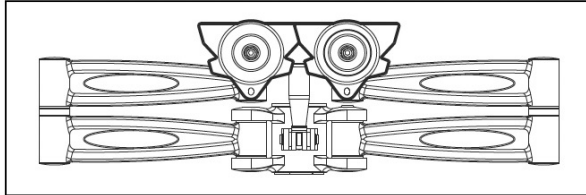
Ne pas utiliser ce produit à des fins autres que celles décrites dans cette notice. Nous déclinons toute responsabilité pour les blessures et dommages résultant d'un montage, installation, ou utilisation incorrects du produit.

Step 1: Remove the arms from the box and rotate the VESA mounting

ÉTAPE 1: Retirez les bras de la boîte et faites pivoter le montage VESA

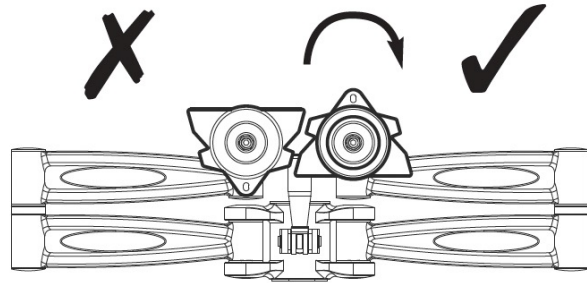
Unpack arm from box.

Déballer les bras de moniteur.



Rotate both VESA mounts to upright position.

Faire pivoter les deux supports de fixation en position verticale.

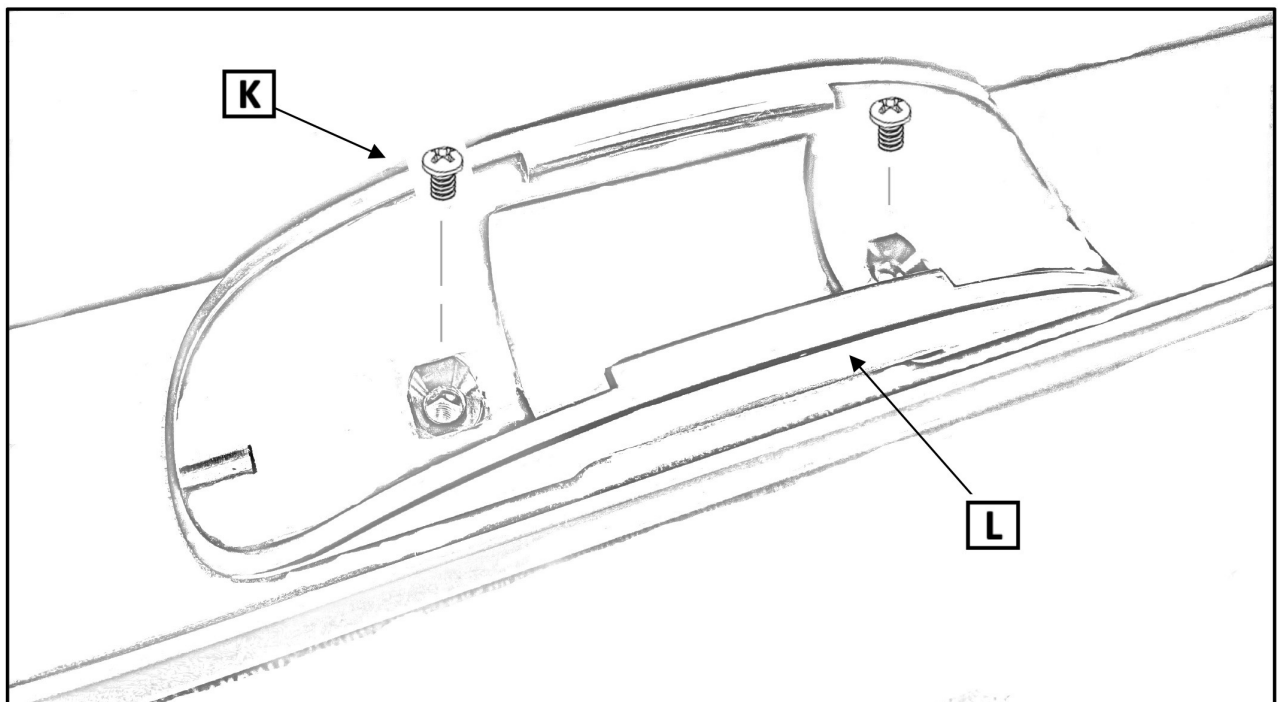


Step 2: Mount pole clip to underside of desktop for pole storage when not in use.

(Not necessary if clip has been pre-installed to desktop)

ÉTAPE 2: Montez le clip de poteau sous le bureau pour le stockage du poteau lorsqu'il n'est pas utilisé.

(Pas nécessaire si le clip a été préinstallé sur le bureau)



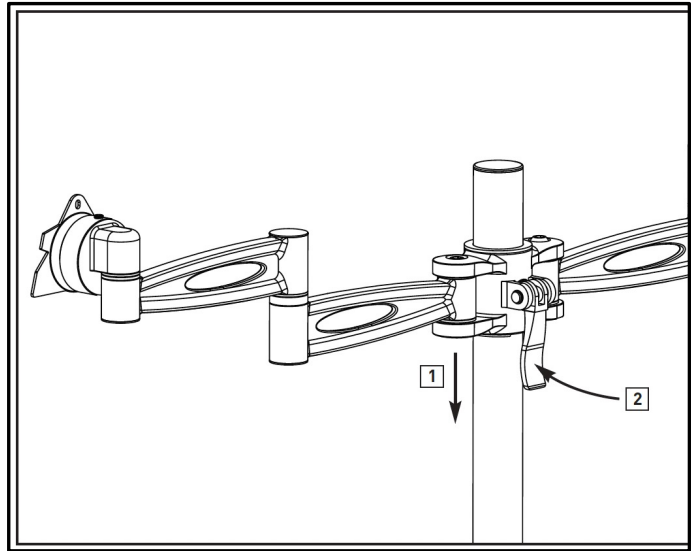
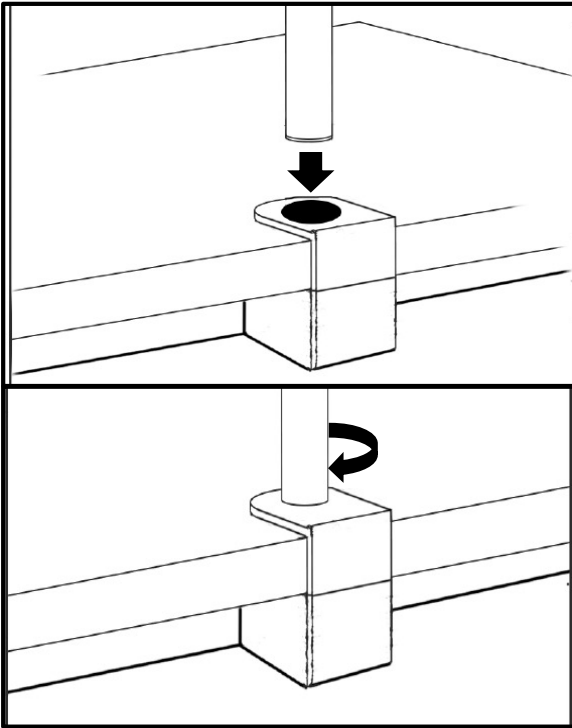
Install Pole and monitor arm:

STEP 3: Insert pole in mounting hole in Desktop and Rotate pole to secure in mounting cube

STEP 4: Slide the swivel arm on to the pole (1) and clamp into position (2)

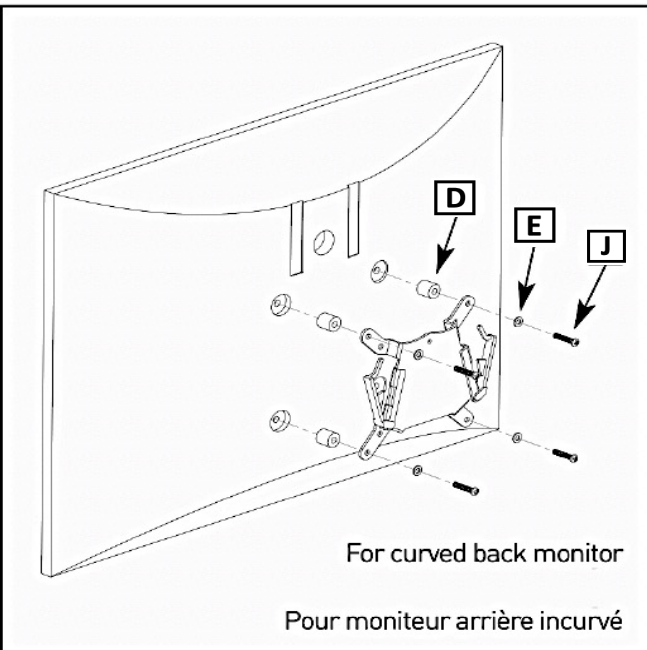
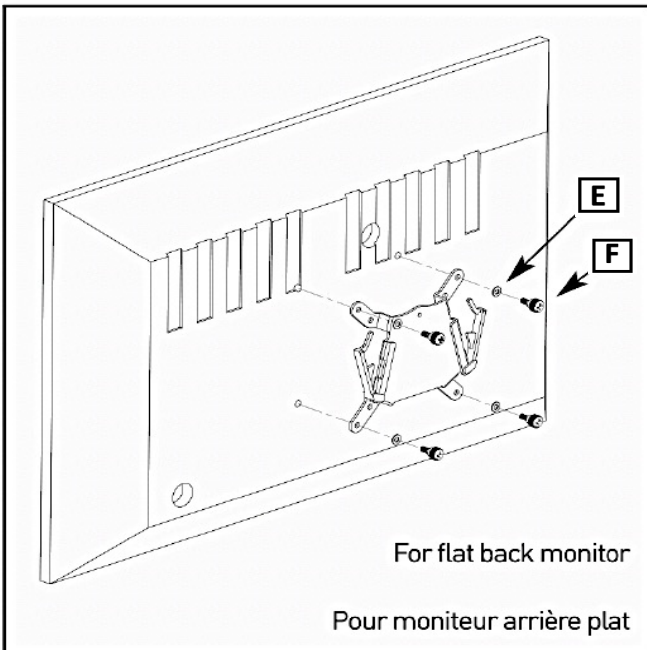
Installer le poteau et le bras du moniteur: ÉTAPE 3: Insérez le poteau dans le trou de montage du bureau et faites pivoter le poteau pour le fixer dans le cube de montage

ÉTAPE 4: Faites glisser le bras pivotant sur le poteau (1) puis verrouillez à la hauteur désirée (2)



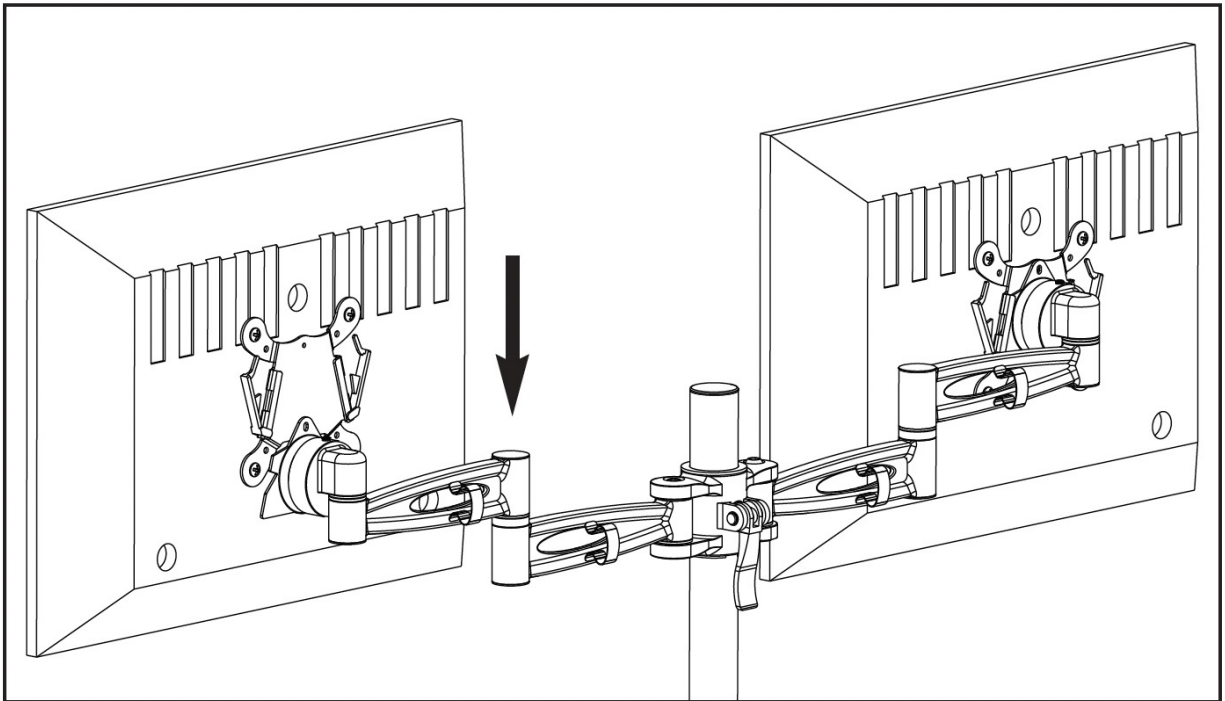
STEP 5: Mount the VESA plate to monitor

ÉTAPE 5: Fixation de la plaque de support VESA au moniteur



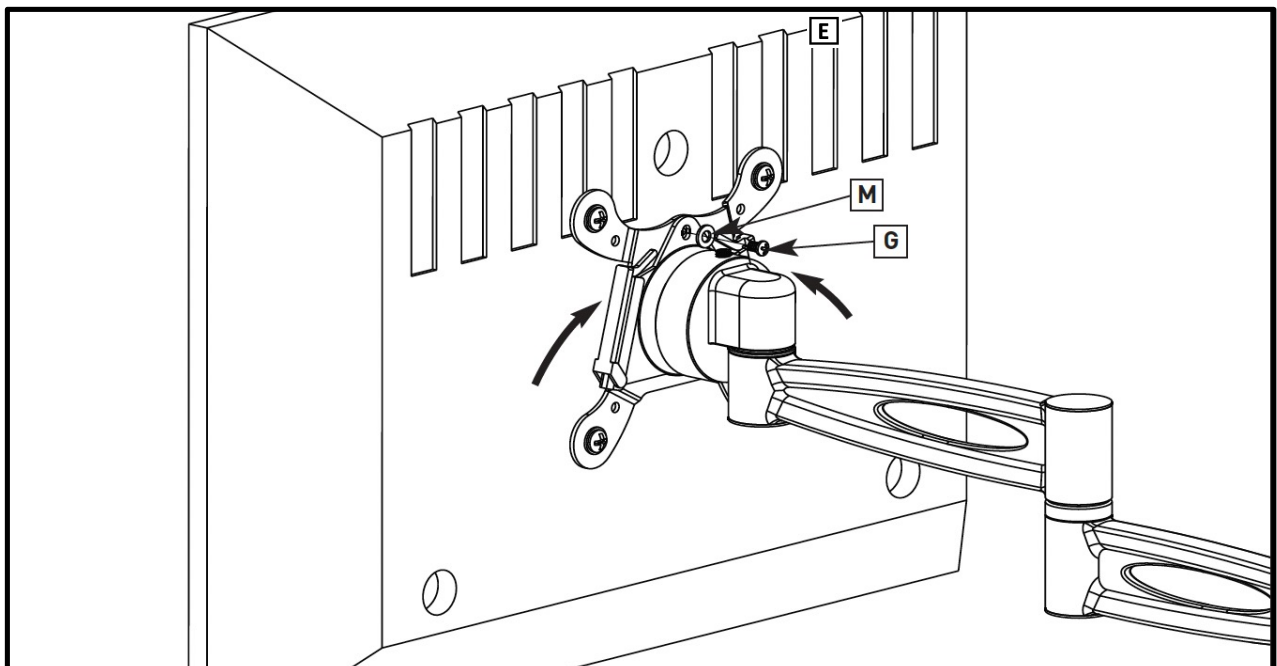
STEP 6: Slide the monitor on to the head of the swivel arm

ÉTAPE 6: Faire glisser le moniteur sur le support de fixation du bras pivotant



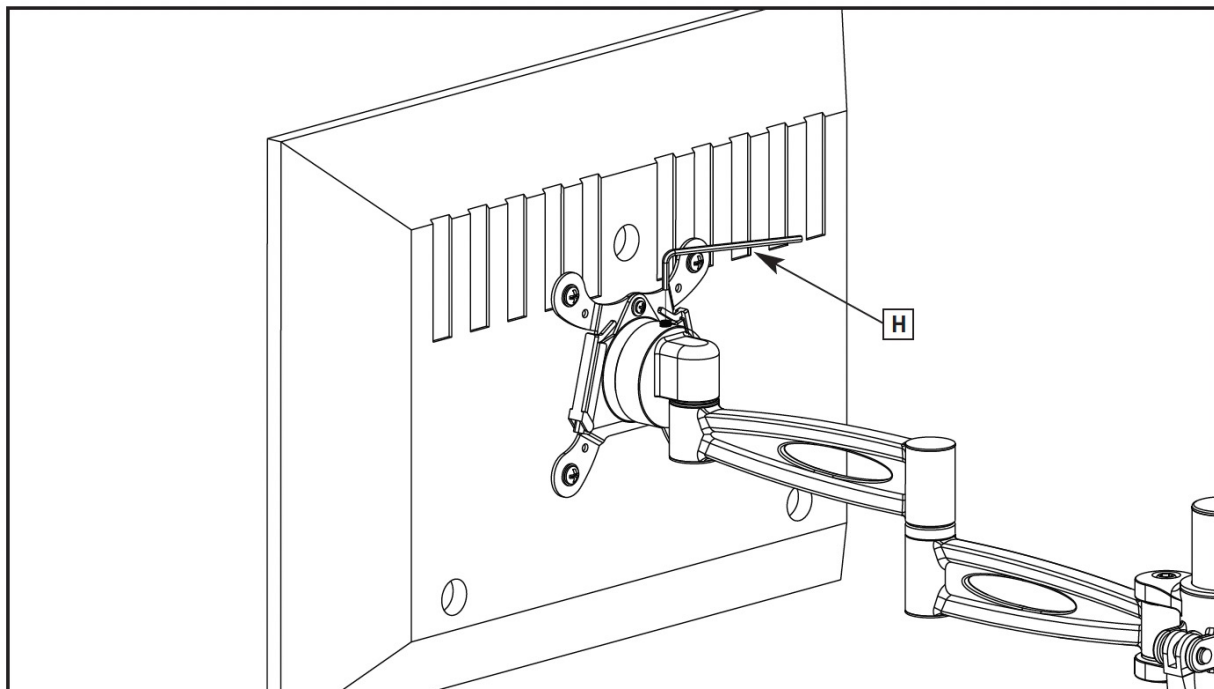
STEP 7: Close the quick locks. Install the optional security screw (G) and washer (E) for more permanent mounting

ÉTAPE 7: Fermez les verrous rapides. Installez la vis de sécurité (G) et la rondelle (E) en option pour un montage plus permanent



STEP 8: ADJUST THE TILT ANGLE
TENSION

ÉTAPE 8: AJUSTER L'ANGLE
D'INCLINAISON



STEP 9: INSTALL CABLE
MANAGEMENT CLIPS AND
STRAPS

ÉTAPE 9: INSTALLER LES PINCES
POUR LE PASSAGE DES CÂBLES

