

SPIRIT



SP-4207 SQUAT RACK

OWNER'S MANUAL

Table Of Contents

Introduction	4
Manufacturer	4
International Offices	4
Customer Support	5
Safety Instructions	6
Precautions	7
Warning Labels and Stickers	17
Safeguards	18
Assembly and Setup	19
Parts List	20
Assembly Instructions	23
Maintenance	26

Copyright 2019. Spirit Fitness® by Dyaco International. All rights reserved, including those to reproduce this book or parts thereof in any form without first obtaining written permission from Spirit Fitness.

Every effort has been made to keep this information current; however, periodically, changes are made to the information herein, and these changes will be incorporated into new editions of this publication. All product names and logos are trademarks of their respective owners.

Introduction

This manual will acquaint you with the assembly, operation and maintenance of your strength equipment. SPIRIT Series **SQUAT RACK** manufactured by Spirit Fitness®

Be sure to read and follow the information and instructions before assembling, using or servicing your Spirit strength equipment.

Manufacturer

Dyaco International Inc.
Taipei HQ Office
12F, No.111, SongJiang Rd.
Taipei City, Taiwan, 10486
Tel: +886-2-2515-2288
Fax: +886-2-2515-9963
Email: info@dyaco.com

International Offices

Spirit Fitness
3000 Nestle Rd.
Jonesboro, AR 72401
TEL: +1-870-935-1107 (Local)
TOLL FREE: +1-800-258-8511 EMAIL:
spiritservice@spiritfitness.com

Dyaco Japan
Dai 2 Shirako Bldg. 501
6-16-7 Nishi Kasai Edogawa
Tokyo 134-0088, Japan
Tel: 03-6808-4588
Fax: 03-6808-4677
Email: info@dyaco.jp

Dyaco Shanghai
Room 1001, Building C,
No.728, ShiGuang Road,
YangPu District, Shanghai, China
Tel: (86) 21-65068300
Fax: (86) 21-65068150

Dyaco UK Ltd
Fairbourne Drive
Atterbury
Milton Keynes
MK10 9RG UK
Tel: +44 (0)800 029 3865
Email: sales@dyaco.co.uk

Dyaco Germany
Technologiepark Bergisch-Gladbach
Haus 56
Friedrich-Ebert-Straße 75
51429 Bergisch Gladbach
Tel: +49 (0)2204 844 340
Fax: +49 (0)2204 844 333
Email: info@dyaco.de

Dyaco Canada
5955 Don Murie Street
Niagara Falls, ONL2G 0A9
Canada
Tel: +1 888-707-1880
Fax: +1 905-353-8968
Email: sales@dyaco.ca

If any items need replacement contact the Spirit Fitness Customer Support Department. For international customers, please contact your local distributor.

Safety Instructions

This chapter includes precautions and fitness safeguards for the installation and use of the **SQUAT RCK** manufactured by **SPIRIT FITNESS**.

Please read this chapter carefully before installing or using your strength equipment.

Live area and Training area

The live area shall be not less than **60cm (24")** greater than the training area in the directions from which the equipment is accessed. The live area must also include the area for easy exit from machine.

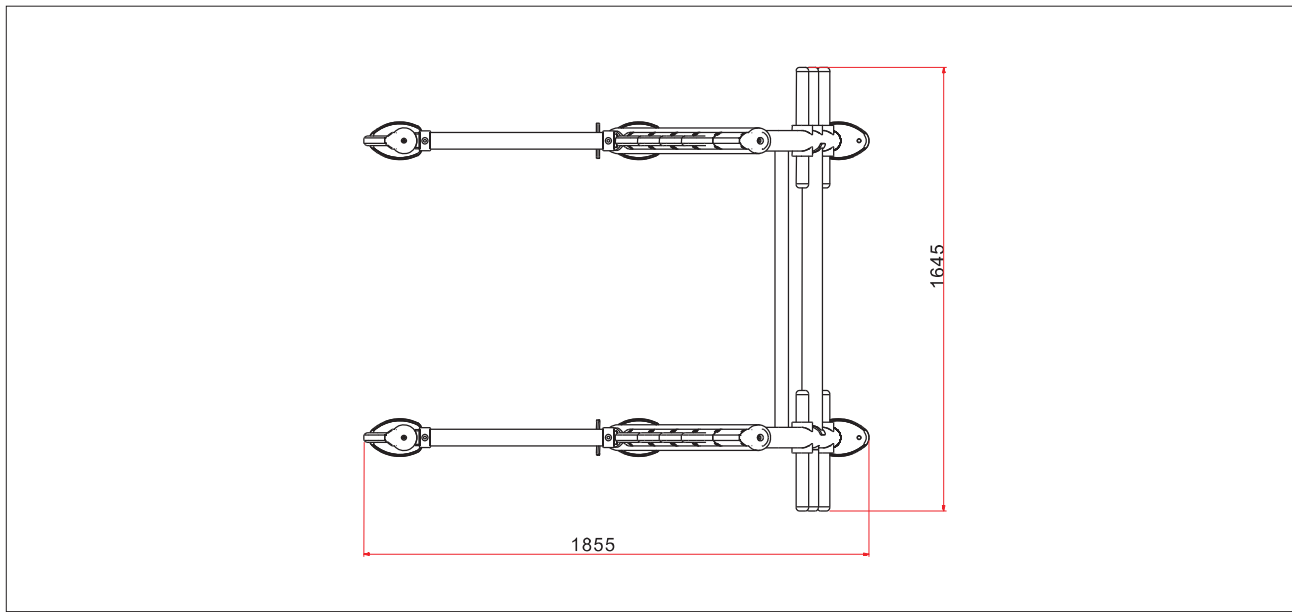

Safety instructions are provided in the following languages (in the order shown):

- English
- Dutch
- French
- German
- Italian
- Portuguese
- Spanish
- Swedish
- Chinese
- Japanese

Precautions

These safety notes are directed to you as the owner of the Strength Equipment manufactured by Spirit Fitness. Please train all your users and fitness staff to follow these safety instructions.

DO

- Do encourage each of your users to discuss their health program or fitness regimen with a healthcare professional.
- Do stop operating your Strength Equipment if you feel dizzy or faint.
- Do perform regular preventative maintenance.
- Do exercise slowly until you reach a level of comfort.

DO NOT

- Do not let unsupervised children operate the Strength Equipment.
- Do not use without proper athletic shoes.
- Do not use outdoors, or in an enclosed pool environment.
- Do not drop or insert any object, hands, or feet into any opening or within the area of the product.
- Do not attempt to remove any shrouds or modify the Strength Equipment.

WARNING

- Your Strength Equipment manufactured by Spirit Fitness is designed for the exercise in a commercial or consumer environment.
- Please check with your physician prior to beginning any exercise program.
- Do not push yourself to excess. Stop if you are feeling faint, dizzy, or exhausted. Use common sense during workout.
- Read the owner's manual in its entirety before operating the Strength Equipment.
- Failure to obey this warning can result in injury or death.

SPIRIT FITNESS® and the Spirit Fitness logo are registered trademarks of Dyaco International.

VOORZORGSMAATREGELEN

Deze veiligheidsaantekeningen zijn aan u gericht als eigenaar van de Strength Equipment manufactured by Spirit Fitness. Gelieve uw gebruikers en uw personeel voor conditietraining volledig bekend te maken met deze veiligheidsinstructies.

Doe het volgende:

- Moedig elk van uw gebruikers aan hun gezondheidsprogramma of conditietherapie met een professioneel uit de gezondheidszorg te bespreken.
- Stop het gebruik van uw Strength Equipment als u zich duizelig of een flauwte voelt.
- Voer regelmatig preventief onderhoud uit.
- Oefen langzaam totdat u een comfortniveau heeft bereikt.
- Gebruik de Strength Equipment alleen voor zijn bedoelde gebruik, zoals in deze handleiding staat beschreven.

Doe het volgende NIET:

- Laat kinderen zonder toezicht de Strength Equipment niet bedienen.
- Niet zonder gymshoenen gebruiken.
- Niet buiten bij regenachtig weer gebruiken, of in dichte ruimte met een zwembad.
- Laat geen enkel voorwerp in de Strength Equipment vallen en steek uw handen of voeten in geen enkele opening van of onder uw Strength Equipment.
- Probeer geen omhulsels te verwijderen of uw Strength Equipment te wijzigen.

WAARSCHUWING

- Uw Strength Equipment manufactured by Spirit Fitness is ontworpen voor aërobische oefeningen in een commerciële of gebruiker-somgeving.
- Zie uw arts vóór het beginnen van een oefenprogramma.
- Dwing uzelf niet tot buitensporige oefeningen. Stop als u zich duizelig, uitgeput of een flauwte voelt.
- Lees de gebruikershandleiding helemaal en aandachtig door alvorens uw Strength Equipment te bedienen.
- Nalaten deze waarschuwing op te volgen kan letsel of overlijden tot gevolg hebben.

PRÉCAUTIONS

Ces consignes de sécurité s'adressent aux propriétaires du Strength Equipment manufactured by Spirit Fitness. Veuillez instruire tous vos utilisateurs et instructeurs à suivre ces consignes.

À Faire

- Encouragez tous les utilisateurs à consulter un médecin au sujet de leur programme de fitness ou régime d'exercice.
- Cessez d'utiliser le Strength Equipment en cas d'étourdissement ou de faiblesse.
- Exécutez régulièrement la maintenance préventive.
- Commencez l'exercice lentement jusqu'à ce que vous atteigniez un niveau confortable.
- Utilisez le Strength Equipment uniquement de la manière prévue, telle que décrite dans ce manuel.

À éviter

- Ne laissez pas des enfants utiliser le Strength Equipment sans surveillance.
- Ne l'utilisez pas sans porter de chaussures d'athlétisme.
- Ne l'utilisez pas en extérieur lors de temps pluvieux, ni en intérieur dans une salle de piscine.
- Évitez de laisser tomber tout objet ou d'introduire les mains ou pieds dans toute ouverture ou en-dessous du Strength Equipment.
- Ne tentez pas de retirer tout carter de protection ni de modifier le Strength Equipment.

AVERTISSEMENT

- Le Strength Equipment manufactured by Spirit Fitness est conçu pour l'exercice aérobie dans un environnement commercial ou privé.
- Veuillez consulter un médecin avant de commencer tout programme d'exercice.
- Ne vous poussez pas au-delà de vos limites. Arrêtez-vous si vous vous sentez faible, étourdi ou épuisé. Faites preuve de bon sens lorsque vous vous entraînez.
- Lisez le guide de l'utilisateur en entier avant d'utiliser le Strength Equipment.
- Le non-respect de ces avertissements peut se traduire par des blessures, voire la mort.

VORSICHTSMASSNAHMEN

Die folgenden Vorsichtsmaßnahmen richten sich an Sie als Besitzer des Strength Equipment manufactured by Spirit Fitness. Bitte schulen Sie alle Ihre Benutzer und Ihr Fitness-Personal in der Beachtung dieser Sicherheitsvorschriften.

Gebote

- Legen Sie jedem Ihrer Benutzer nahe, sein Gesundheits- oder Fitnessprogramm mit einem medizinischen Fachmann zu besprechen.
- Beenden Sie den Betrieb Ihres Strength Equipment, wenn Sie sich schwindelig oder schwach fühlen.
- Führen Sie regelmäßige vorbeugende Wartungsmaßnahmen durch.
- Trainieren Sie langsam, bis Sie eine gewisse Komfortzone erreichen.
- Verwenden Sie den Strength Equipment nur zum vorgesehenen, in dieser Anleitung beschriebenen Zweck.

Verbote

- Lassen Sie den Strength Equipment nicht von unbeaufsichtigten Kindern in Betrieb nehmen.
- Benutzen Sie das Gerät nicht ohne Sportschuhe.
- Benutzen Sie das Gerät bei regnerischen Witterungsbedingungen nicht im Freien und nicht in einer geschlossenen Schwimmbadumgebung.
- Lassen Sie keine Gegenstände in irgendwelche Öffnungen oder unter den Strength Equipment fallen und halten Sie Hände und Füße von diesen Bereichen fern.
- Unternehmen Sie keinen Versuch, irgendwelche Abdeckungen zu entfernen oder den Strength Equipment zu modifizieren.

ACHTUNG

- Der Strength Equipment manufactured by Spirit Fitness ist für aerobische Übungen in einer kommerziellen oder Verbraucherumgebung vorgesehen.
- Bitte holen Sie vor Aufnahme eines jeden Trainingsprogramms den Rat Ihres Arztes ein.
- Trainieren Sie nicht übertrieben hart. Hören Sie auf, wenn Sie ein Schwäche-, Schwindel- oder Erschöpfungsgefühl verspüren. Lassen Sie sich beim Schrittraining von Ihrer Vernunft leiten. Lesen Sie vor Inbetriebnahme Ihres Strength Equipment die Bedienungsanleitung vollständig durch.
- Ein Missachten dieses Achtungshinweises kann Verletzungen oder den Tod zur Folge haben.

PRECAUZIONI

Queste note precauzionali sono dirette a voi, come proprietario dello Strength Equipment manufactured by Spirit Fitness. Siete pregati di istruire i vostri utenti e il vostro personale all'osservanza di queste precauzioni

Da Fare

- Incoraggiate i vostri utenti a discutere il loro programma di salute o di fitness con uno specialista dell'healthcare.
- Interrompete l'uso dello Strength Equipment se avete giramenti di testa o se vi sentite mancare.
- Eseguite periodicamente servizi di manutenzione.
- Utilizzate lo Strength Equipment soltanto per l'uso a cui è destinato, come descritto nel manuale.

Da Non Fare

- Non consentite a bambini di usare lo Strength Equipment senza la supervisione di un adulto.
- Non utilizzate lo Strength Equipment senza scarpe atletiche.
- Non utilizzate lo Strength Equipment all'esterno in condizioni piovose o in un ambiente con piscina interna.
- Non lasciate cadere oggetti sullo Strength Equipment e non inserite oggetti, mani o piedi in qualsiasi apertura esterna o sotto lo Strength Equipment.
- Non cercate di rimuovere le coperture o di modificare lo Strength Equipment.

AVVERTENZE

- Lo Strength Equipment manufactured by Spirit Fitness è stato realizzato per esercizi di aerobica in un ambiente pubblico o privato adeguato.
- Prima di iniziare un programma di esercizio fisico, consultate il vostro medico.
- Non eccedete i vostri limiti. Fermatevi se vi sentite mancare, se avete giramenti di testa o se vi sentite esausti. Usate buon senso nell'utilizzo dell'attrezzatura.
- Leggete il Manuale dell'utente interamente prima di utilizzare lo Spinner.
- La mancata osservanza di queste avvertenze può comportare lesioni gravi o morte.

PRECAUÇÕES

Estas notas de segurança destinam-se a você, proprietário do Strength Equipment manufactured by Spirit Fitness. Treine todos os usuários e o pessoal da academia para que sigam estas instruções de segurança.

O que fazer

- Incentive todos os usuários a discutirem seu programa de saúde ou sistema de condicionamento físico com um profissional da área de saúde.
- Pare o funcionamento do Strength Equipment se sentir tontura ou vertigem.
- Efetue a manutenção preventiva regular.
- Faça exercícios lentamente até atingir um grau de conforto.
- Use o Strength Equipment apenas de acordo com a finalidade para que se destina, conforme descrito neste manual.

O que não fazer

- Não deixe crianças sem supervisão operarem o Strength Equipment.
- Não use sem os sapatos esportivos apropriados.
- Não utilize em ambientes externos quando o tempo estiver chuvoso, nem em um ambiente fechado de piscina interna.
- Não deixe cair nem insira nenhum objeto, mãos ou pés em qualquer abertura ou sob o Strength Equipment. Não tente remover nenhum degrau nem modificar seu Strength Equipment.

ADVERTÊNCIA

- Seu Strength Equipment manufactured by Spirit Fitness foi projetado para exercícios aeróbicos em um ambiente comercial ou próprio do consumidor.
- Consulte seu médico antes de começar qualquer programa de exercícios.
- Não se esforce demais. Pare se sentir tontura, vertigem ou exaustão. Tenha bom senso ao fazer o exercício. Leia todo o Manual do Proprietário antes de operar o seu Strength Equipment.
- Deixar de observar esta advertência pode resultar em ferimentos ou morte.

PRECAUCIONES

Estas notas de seguridad están dirigidas a usted como el dueño de Strength Equipment manufactured by Spirit Fitness. Por favor instruya a todos sus usuarios y personal de entrenamiento para que sigan estas instrucciones de seguridad.

Lo que se debe hacer

- Dígale a cada uno de sus usuarios que discuta su programa de salud o régimen de ejercicio con un profesional de la salud.
- Deje de operar su Strength Equipment si se siente mareado o como que va a desmayarse.
- Lleve a cabo mantenimiento preventivo a intervalos regulares.
- Haga ejercicio lentamente hasta que alcance un nivel en el que se sienta cómodo.
- Utilice el Strength Equipment solamente para lo que fue diseñado, como se describe en este manual.

Lo que no se debe hacer

- No permita que los niños operen su Strength Equipment sin supervisión.
- No lo use sin zapatos atléticos.
- No lo utilice afuera en la lluvia ni en un ambiente cerrado donde haya una piscina.
- No lo deje caer ni inserte objetos, manos o pies en ninguna apertura de su Strength Equipment ni debajo de él.
- No intente quitar ninguna cubierta o recubrimiento ni modificar su Strength Equipment.

ADVERTENCIA

- Su Strength Equipment manufactured by Spirit Fitness está diseñado para el ejercicio aeróbico en un ambiente comercial o de consumo.
- Por favor consulte con su médico antes de iniciar cualquier programa de ejercicio.
- No haga un esfuerzo excesivo. Deténgase si se siente mareado, exhausto o como si fuera a desmayarse. Use su sentido común al hacer ejercicio.
- Lea completamente el Manual del dueño antes de operar su Spinner.
- El no cumplir con esta advertencia puede resultar en una lesión o en la muerte.

FÖRSIKTIGHETSÅTGÄRDER

Dessa säkerhetsanmärkingar är riktade till dig i egenskap av ägare av Strength Equipment manufactured by Spirit Fitness. Var god utbilda alla användare och all personal att följa dessa säkerhetsanvisningar.

Man ska

- Uppmuntra alla användare att konsultera sitt hälso- program eller sin träningsregim med en läkare.
- Sluta använda Strength Equipment om man känner sig yr eller svim- färdig.
- Utföra regelbundet underhåll i förebyggande syfte.
- Motionera långsamt tills man når en komfortnivå.
- Endast använda Strength Equipment för dess avsedda användning, enligt beskrivning i denna handbok.

Man ska inte

- Låta barn använda Strength Equipment utan uppsikt.
- Använda Strength Equipment utan sportskor.
- Använda Strength Equipment utomhus i fuktigt väder eller i ett innes- lutet bassängområde.
- Tappa in eller föra in något föremål, händer eller fötter i någon öppning, eller under Strength Equipment.
- Försöka att avlägsna några skyddskåpor eller att modi- fiera Strength Equipment.

VARNINGAR

- Din Strength Equipment manufactured by Spirit Fitness är avsedd för aerobisk träning i kommersiella eller konsumentinriktade miljöer.
- Konsultera din läkare innan du inleder något träningsprogram.
- Sluta om du känner dig yr, svimfärdig eller utmattad. Använd Strength Equipment sunt förnuft. Läs igenom hela handboken innan du använder Strength Equipment.
- Underlåtelse att iaktta dessa varningar kan medföra skada eller dödsfall.

注意事項

下述安全說明適用於您所擁有的由 Spirit Fitness 製造之重訓設備。請培訓所有使用者與健身人員遵守下述安全說明。

遵守事項

- 鼓勵您的每個使用者在使用此重訓設備前，與專業的醫療保健專業人員討論他們的健康計劃或健身方案。
- 如果您感到頭暈或虛弱，請停止使用此重訓設備。
- 請定期進行預防性維護。
- 請緩慢且循序漸進使用此重訓設備，直至達到舒適程度。

禁止事項

- 請勿讓無人監管的兒童操作此重訓設備。
- 請勿在沒有穿著合適的運動鞋的狀況下使用此重訓設備。
- 請勿在戶外陰雨天氣或封閉的泳池環境中使用此重訓設備。
- 請勿讓任何物體、手或腳掉入或插入任何開口或重訓設備運動範圍內。
請勿嘗試拆除任何零件或修改此產品。

警告

- 您所擁有的由 Spirit Fitness 製造之重訓設備，專為商業或消費環境中的運動而設計。
- 在開始任何鍛煉計劃之前，請諮詢您的醫生。
- 請勿讓自己運動過量。如果你感到昏厥，頭暈或疲憊，請停止使用。使用此重訓設備時要運用一般常識。
- 在使用此重訓設備之前，請完整閱讀使用者手冊。
- 不遵守上述警告可能導致人身傷害或死亡。

注意事項

これらの安全に関する注意事項は、Spirit Fitness 社が製造した Strength Equipment のオーナーとしてお客様に向け示されています。これらの安全に関する指示や注意事項に従うように、すべてのユーザーやフィットネススタッフをトレーニングしてください。

DO（行ってください）

- 各ユーザーが各自の健康プログラムやフィットネスプログラムについて、必ず医療従事者や専門家と相談する事を強く奨励します。
- 使用前、使用中にめまいや気分が悪いと感じた場合は、直ちにバイクの使用をやめてエクササイズを中止してください。
- エクササイズバイクの定期的な予防メンテナンスを行ってください。
- 行っているエクササイズが快適に感じるまではゆっくりと運動してください。

DO NOT（行わないでください）

- 監督なしでの子供の自転車使用を禁止してください。
- 適切な運動靴なしで使用しないでください。
- 雨天時の屋外や屋内プールでの使用は避けてください。
- フライホイールの開口部やその付近に物、手、足、指等を落としたり、入れたり、触れたりしないようにしてください。
- カバーや覆いを取り外したり、このエクササイズバイクを改造しないでください。

警告

- この **Strength Equipment** は **Spirit Fitness** 社によって製造された、業務使用目的または個人使用目的の有酸素運動用に設計されたエクササイズバイクです。
- エクササイズプログラムを始める前に必ず医師にユーザー自身の健康状態を相談してください。
- 自分自身のレベルを超えた過度なエクササイズは避けてください。わずかでも、体調不良やめまいを感じたり、疲労を感じた場合は直ちにエクササイズを中止して、使用を止めてください。エクササイズバイクの使用には適切な常識を適用する事をお勧めいたします。
- エクササイズバイクを使用する前に、取扱説明書すべてを読み理解してください。
- この警告に従わない場合は、重篤な事故、怪我や死亡に繋がる可能性があります。

Warning Labels and Communication Stickers

The following pages show examples of Spirit Fitness® warning labels and communication stickers placed on the equipment as part of the manufacturing process. It is critical that owners maintain the integrity and placement of these stickers. If you find any stickers missing or damaged contact your local dealer or distributor for a replacement.

If any instructions or information are not clear, and please contact to SPIRIT FITNESS customer service right away.

NOTE: STICKERS AND LABELS ARE NOT SHOWN TO SCALE



Warning Decal

⚠ WARNING

- READ AND FOLLOW ALL PROPER INSTRUCTIONS PRIOR TO USING THE EQUIPMENT. IMPROPER USE CAN RESULT IN SERIOUS INJURY AND SHOULD ONLY BE USED IN A SUPERVISED ENVIRONMENT.
- AS WITH ALL EXERCISE EQUIPMENT OR PROGRAMS, CONSULT A PHYSICIAN PRIOR TO USE AND STOP IF YOU FEEL FAINT, DIZZY OR EXHAUSTED.
- INSPECT MACHINE PRIOR TO USE. IMMEDIATELY REPORT WORN, LOOSE OR DAMAGED EQUIPMENT TO MANAGEMENT AND REFRAIN FROM USING EQUIPMENT.
- ENSURE ALL ADJUSTMENT AND LOCKING FEATURES ARE PROPERLY SECURED BEFORE USING THE EQUIPMENT.
- ENSURE WEIGHT SELECTOR PIN IS FULLY INSERTED INTO THE WEIGHT PLATE BEFORE USE.
- KEEP CLEAR OF MOVING PARTS TO AVOID INJURY.
- REPLACE LABEL IF DAMAGED, ILLEGIBLE OR REMOVED.

California Prop 65 Warning Decal (For US model only)

⚠ WARNING: Cancer and Reproductive Harm - www.P65Warnings.ca.gov

Serial Number Decal

SPIRIT

MODEL NUMBER: SP-4207
 PRODUCT : SQUAT RACK
 COMPLIES WITH EN 957-1/2
 CLASS: S STUDIO
 MAX USER WEIGHT : 180 KG / 396 LBS
 SERIAL NUMBER: SP-42071906001

CE

 MADE IN CHINA

Safeguards

The following fitness safeguards and operating precautions are directed to purchasers and users of the Spirit Fitness strength equipment. Club Managers should ensure that members and fitness staff are trained to follow these same instructions. Failure to follow these safeguards may result in injury or serious health risk.

Proper Usage

- Do not use any equipment in any way other than designed or intended by the manufacturer. It is imperative that SPIRIT FITNESS equipment is used properly to avoid injury.
- Injuries may result if exercising improperly or excessively. It is recommended that all individuals consult a physician prior to commencing an exercise program. If at any time during exercise you feel faint, dizzy or experience pain. STOP EXERCISING and consult your physician.
- Keep body parts (hands, feet, hair, etc.), clothing and jewelry away from moving parts to avoid injury.
- Follow instructions provided in this manual for correct foot position and basic techniques.
- The maximum weight for individuals using the Strength Equipment should not exceed 180kg (400 lbs).

Inspection

- DO NOT use or permit use of any equipment that is damaged and/or has worn or broken parts. For all SPIRIT FITNESS equipment use only replacement parts supplied by SPIRIT FITNESS.
- Cables and belts pose an extreme liability if used when frayed. Always replace any cable or belt at first sign of wear (consult SPIRIT FITNESS if uncertain).
- EQUIPMENT MAINTENANCE - Preventative maintenance is the key to smooth operating equipment as well as to keep your liability to a minimum. Equipment needs to be inspected at regular intervals. Refer to the maintenance section of the manual.
- Ensure that any person(s) making adjustments or performing maintenance or repair of any kind is qualified to do so.
- DO NOT ATTEMPT TO USE OR REPAIR ANY ACCESSORY APPROVED FOR USE WITH THE SPIRIT FITNESS EQUIPMENT WHICH APPEARS TO BE DAMAGED OR WORN.
- Check all belts, pulleys and bungee cords regularly for signs of wear, and replace if needed.
- Check regularly and follow all instructions for maintenance as specified in this manual.
- Replace immediately any defective parts and do not operate unit until all repairs are complete.

Operating Warnings

- Keep children away from the equipment. Parents or others supervising children must provide close supervision of children if the equipment is used in the presence of children.
- Do not allow users to wear loose fitting clothing or jewelry while using equipment. It is also recommended to have users' secure long hair back and up to avoid contact with moving parts.
- All bystanders must stay clear of all users, moving parts and attached accessories and components while machine is in operation. Live area and Training area.

Note: This Strength Equipment is not suitable for therapeutic purposes.

Assembly & Setup

Use the following procedures to unpack and assemble your Strength Equipment by Spirit Fitness.

Unpacking & Parts

1. Position the shipping carton so the Heavy End is located at the bottom.
2. Cut the straps then lift the box over the unit and unpack. Remove all parts from the shipping carton and foam inserts, and verify that all parts are included in your shipment:
3. Locate the hardware package. The hardware is separated into 3 steps. Remove the tools first. Remove the hardware for each step as needed to avoid confusion. The numbers in the instructions that are in parenthesis (#) are the item number from the assembly drawing for reference.

NOTE: All tools required to assemble the Strength Equipment are included within the packaging.

Take time now to enter your Strength Equipment serial number in the space below.
(Serial number is located on the center tube, see page 16).

Serial No. _____

NOTE: If you are missing any of the parts listed above, inspect the packing material and the box for items that may have been overlooked.

If parts are missing, or if you have any operational questions, please call your local Spirit Fitness's Service department or the distributor whom sold you the product. Please see page 4 for a listing of international corporate offices and locate the office nearest you. Have your serial number ready.

CAUTION: Damage to the Strength Equipment during assembly is not covered as part of the limited Spirit Fitness warranty. Take care not to drop or lean the Strength Equipment on its side. Carefully stand the Strength Equipment up in the normal upright position on a stable surface so it will not tip over during assembly.

Protect the environment by not disposing of this product with household waste. Check your local authority or approved waste center for recycling advice and facilities.

Product Specifications

Maximum Training Weight	180 kg / 400 lbs
Products Weight	132 kg / 290 lbs
Overall Dimensions	1855*1645*2010

Parts List

PART NO.	QTY	DESCRIPTION
SP-4207-001	2	Foot Frame
SP-4207-002	1	Lower Joint Frame
SP-4207-003	1	Upper Joint Frame
SP-4207-004	2	Front Stand
SP-4207-005	4	Long Barbell Pipe
SP-4207-006	2	Short Barbell Pipe
SP-4207-007	2	Long Protecting Jacket
SP-4207-008	6	Protecting Jacket
SP-4207-009	10	Barbell Bushing
SP-4207-010	10	Pipe Plug
SP-4207-011	4	Protecting Jacket
SP-4207-012	4	Plastic Stopper
SP-4207-013	6	Rubber Mat
SP-4207-014	4	Upper Protecting Jacket
SP-4207-015	4	Lower Protecting Jacket
SP-4207-016	10	Left Hook Jacket
SP-4207-017	10	Middle Hook Jacket
SP-4207-018	10	Right Hook Jacket
SP-4207-019	4	Left Extend Jacket
SP-4207-020	4	Middle Extend Jacket
SP-4207-021	4	Right Extend Jacket
SP-4207-022	8	Hex Socket Head Cap Screw M12*30
SP-4207-023	8	Hex Socket Head Cap Screw M12*90
SP-4207-024	4	Hex Socket Head Cap Screw M10*100
SP-4207-025	4	Hex Socket Head Cap Screw M12*130
SP-4207-026	4	Hexagon Socket Button Head Screw M8*35
SP-4207-027	8	Hexagon Socket Button Head Screw M8*30
SP-4207-028	10	Hexagon Socket Button Head Screw M6*25
SP-4207-029	76	Cross Head Modified Truss Head Screw M5*12
SP-4207-030	12	Hexagon Socket Set Screws with Flat Point M6*6
SP-4207-031	36	Plain Washer $\Phi 24 \times \Phi 13 \times 2.5$
SP-4207-032	8	Plain Washer $\Phi 20 \times \Phi 10.5 \times 2$
SP-4207-033	12	Plain Washer $\Phi 16 \times \Phi 8.4 \times 1.6$
SP-4207-034	10	Extra Large Washer $\Phi 22 \times \Phi 6.6 \times 2$
SP-4207-035	12	Spring Washer M8
SP-4207-036	10	Spring Washer M6
SP-4207-037	16	Nylon Insert Lock Nut M12
SP-4207-038	4	Nylon Insert Lock Nut M10
SP-4207-039	10	Reed Nut M6*33.8*15
SP-4207-040	8	Flat Head Rivet Nut M8*18
SP-4207-041	2	Plate
SP-4207-042	4	Spring Washer M12

Parts List

PART NO.	QTY	DESCRIPTION
SP-4207-043	4	Spring Washer M10
SP-4207-044	4	Hexagon Rivet Nut With Flat Head M10*19.5
SP-4207-045	4	Space Bush
SP-4207-046	4	Hexagon Socket Button Head Screw M10*40

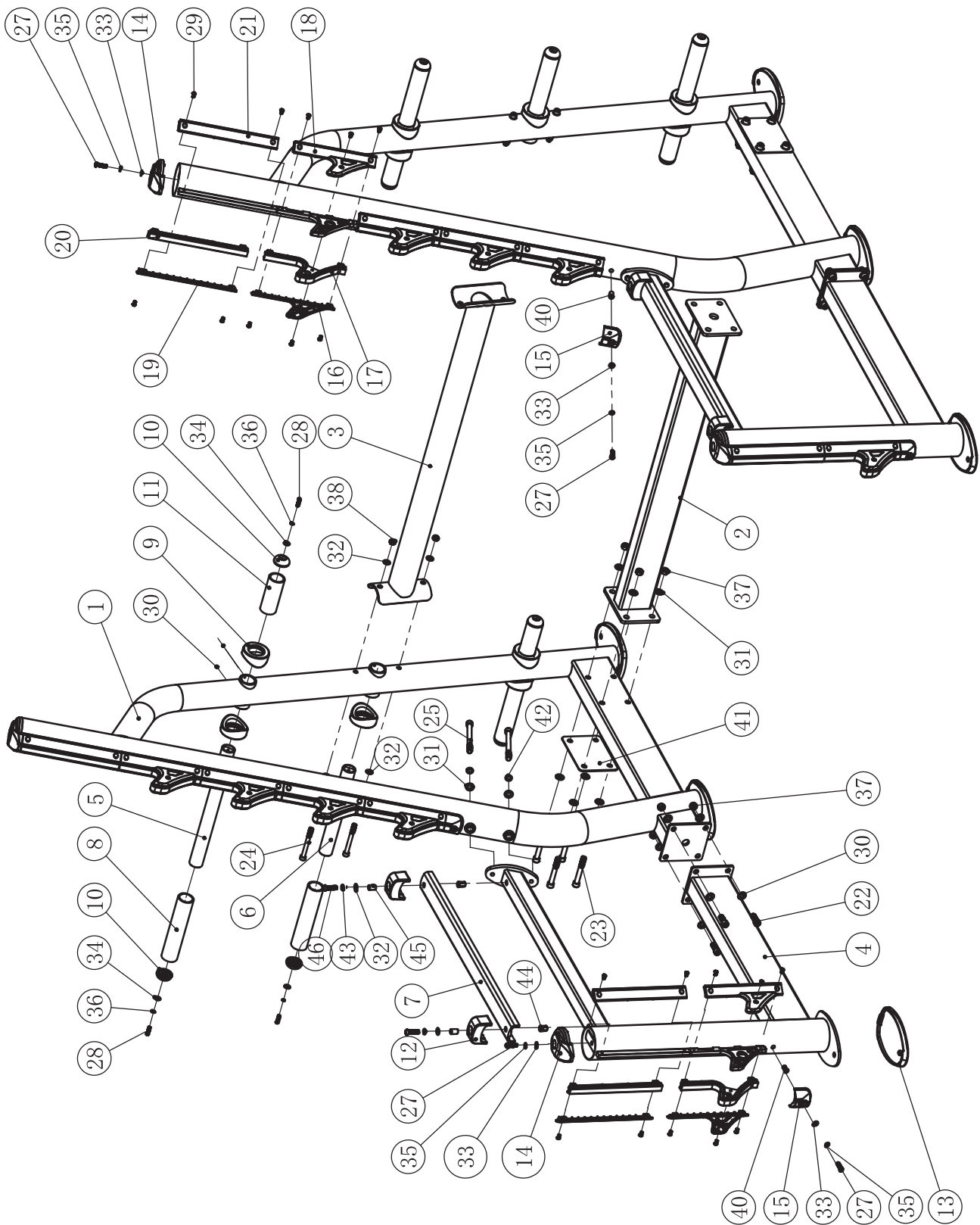

Assembly Instructions

STEP 1

STEP	No.	Qty	Description
1	SP-4207-023	8	Hex Socket Head Cap Screw M12*90
	SP-4207-024	4	Hex Socket Head Cap Screw M10*100
	SP-4207-031	16	Plain Washer $\Phi 24 \times \Phi 13 \times 2.5$
	SP-4207-032	8	Plain Washer $\Phi 20 \times \Phi 10.5 \times 2$
	SP-4207-037	8	Nylon Insert Lock Nut M12
	SP-4207-038	4	Nylon Insert Lock Nut M10

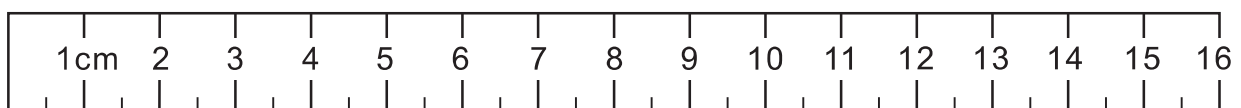
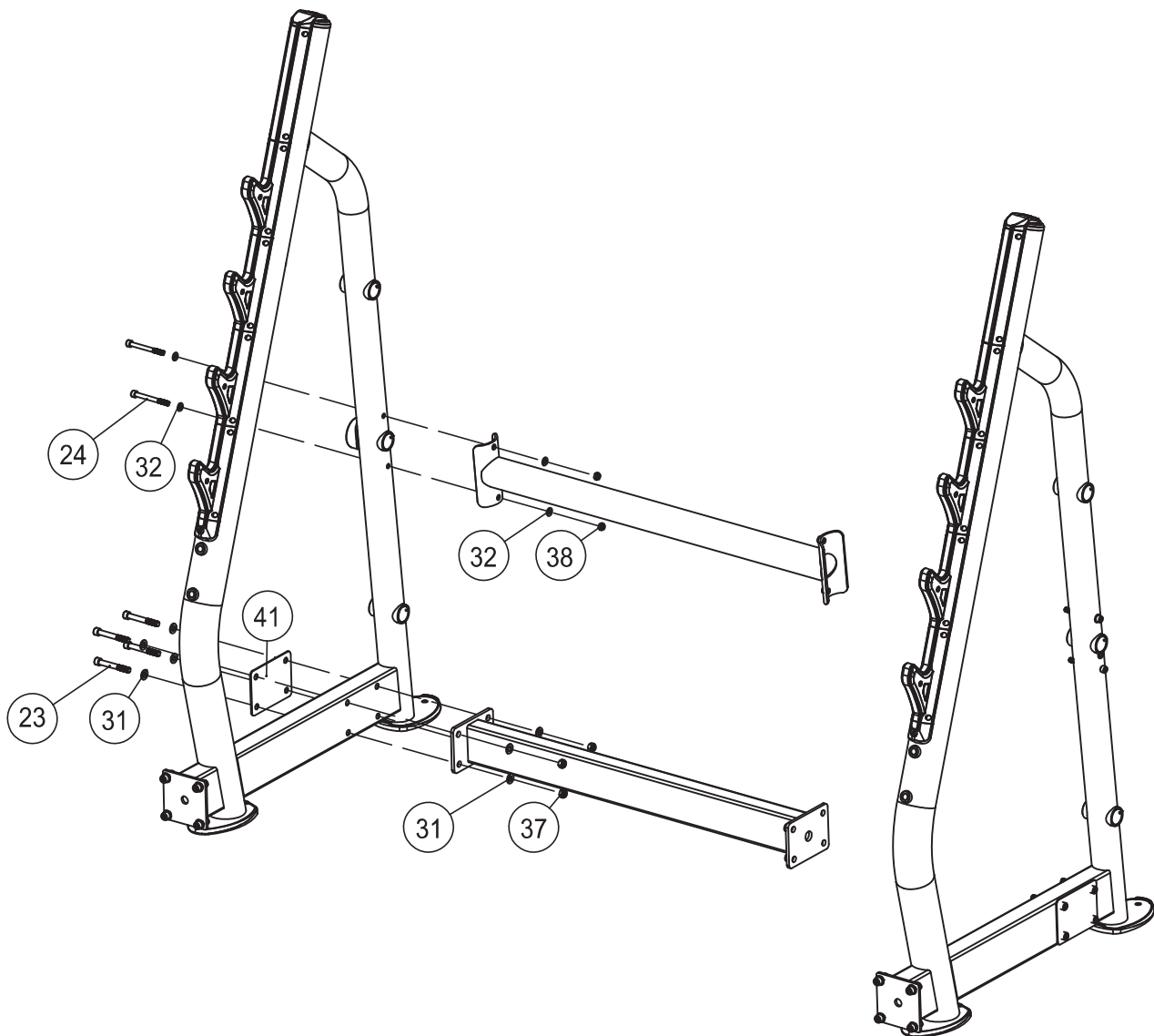

Assembly Instructions

STEP 2

STEP	No.	Qty	Description
2	SP-4207-022	8	Hex Socket Head Cap Screw M12*30
	SP-4207-025	4	Hex Socket Head Cap Screw M12*130
	SP-4207-031	20	Plain Washer $\Phi 24^* \Phi 13^* 2.5$
	SP-4207-037	8	Nylon Insert Lock Nut M12
	SP-4207-042	4	Spring Washer M12

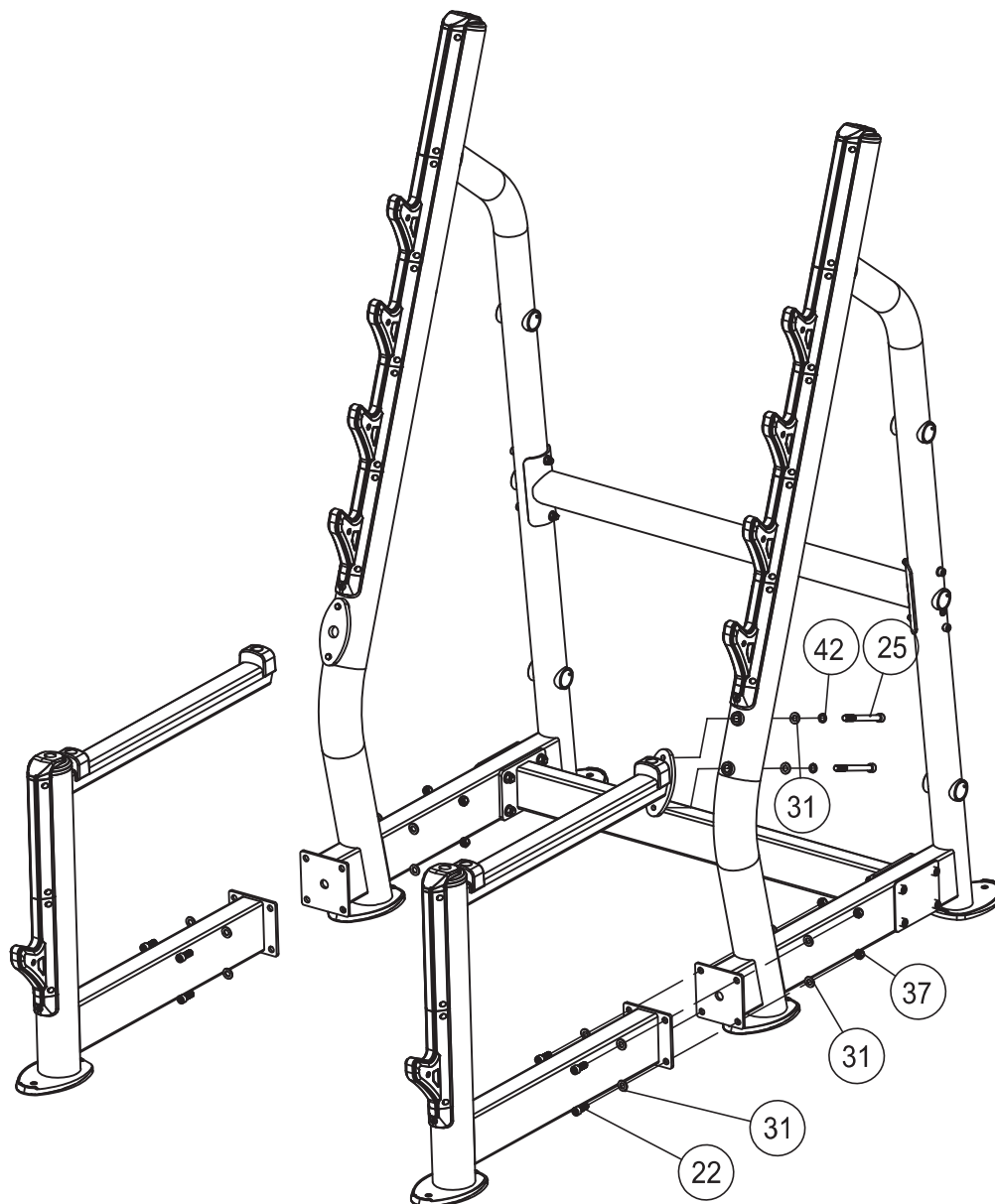

Assembly Instructions

STEP 3

STEP	No.	Qty	Description
3	SP-4207-009	10	Barbell Bushing
	SP-4207-010	10	Pipe Plug
	SP-4207-011	4	Protecting Jacket
	SP-4207-028	10	Hexagon Socket Button Head Screw M6*25
	SP-4207-030	12	Hexagon Socket Set Screws with Flat Point M6*6
	SP-4207-034	10	Extra Large Washer $\Phi 22 \times \Phi 6.6 \times 2$
	SP-4207-036	10	Spring Washer M6

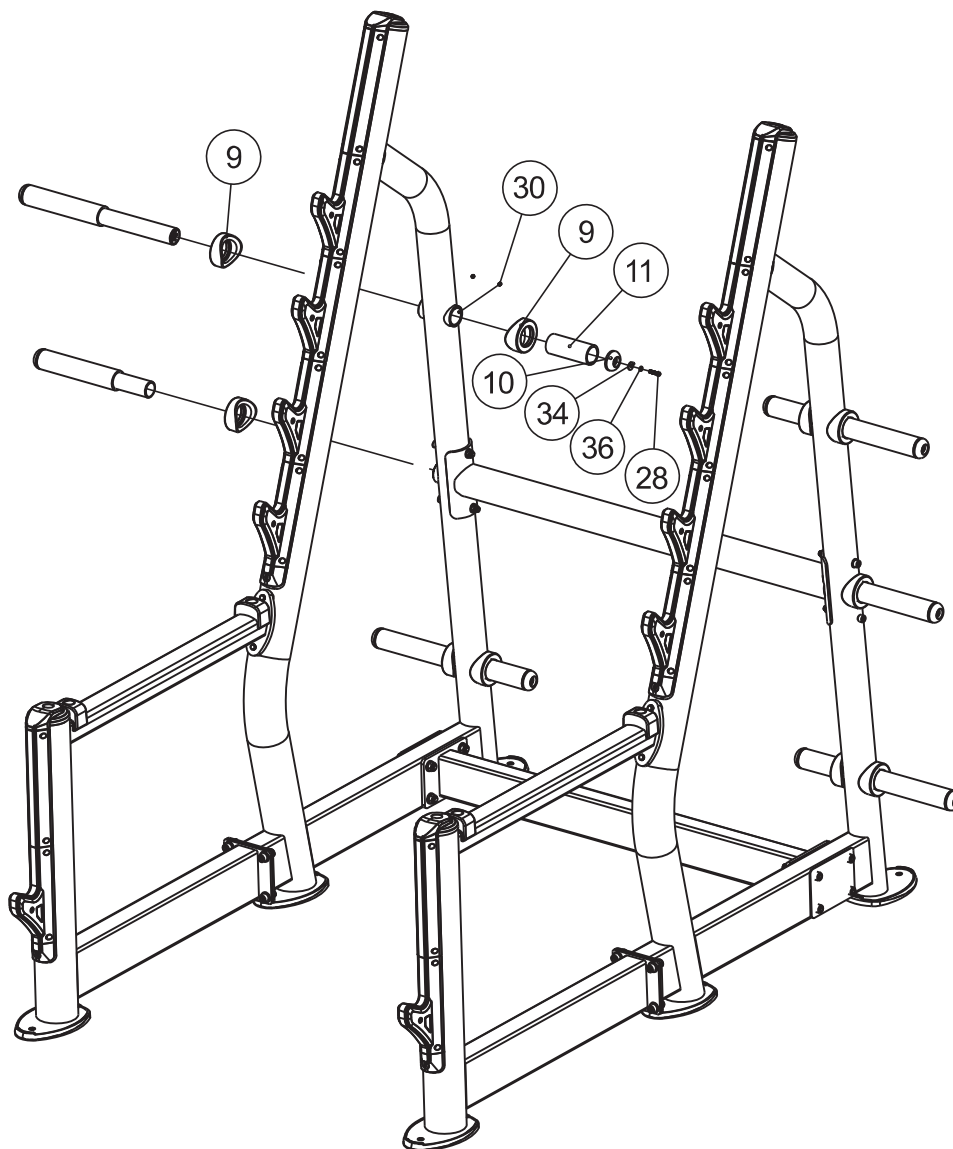

Maintenance

A regular preventative maintenance schedule with all fitness equipment ensures that products are working at an optimal condition without affecting the end user exercise experience. To assist in the maintenance regiment, it is recommended to break service into: Daily, Weekly, Monthly & Quarterly activities.

Spirit Fitness strongly recommends performing regular preventive maintenance on your equipment. Without regularly scheduled maintenance, normal wear and tear may cause cumulative effects, such as misalignment or premature wear, resulting in downtime. For this reason, we highly recommend following the maintenance schedules. Additionally, unusual symptoms, such as excessive noise during use, stiffness or free play in moving parts, etc., should be investigated and necessary corrective actions (adjustment or parts replacement) should be performed. If any components are found to be worn or damaged, the unit should be removed from service until repairs can be made. Only components supplied or approved by Spirit Fitness shall be used to maintain and/or repair the unit.

DAILY MAINTENANCE

- Wipe down and inspect the framework and other structural components
- Check all attaching hardware for security. Tighten as needed.
- Clean and inspect the upholstered cushions and the hand grips.

WEEKLY MAINTENANCE

- Check all labels and placards affixed to the unit for legibility and security. Replace illegible labels and placards as needed

QUARTERLY MAINTENANCE

- Apply wax to powder-coated areas of the framework and other structural components.

FRAMEWORK MAINTENANCE

CAUTION: DO NOT use lacquer thinner, acetone, or other solvents to clean powder-coated finishes on the framework or other structural components. Solvents will dull the finish, and contain components that may remove the epoxy-based powder from the frame.

Framework and other structural components should be wiped down on a daily basis using a moistened with water. This will increase the longevity of protective powder-coat finishes. The framework should be inspected while cleaning for evidence of fatigue cracks, scratches or chips in the finish, loose hardware, worn or damaged weight cable, and other areas that may require attention.

Apply easy-application car wax to all powder-coated surfaces quarterly. Regular waxing will aid in preventing premature rusting due to corrosives found in perspiration, and will allow loose particles to be removed more easily when performing the daily wipe-down.

Procedures to repair scratches and chips depend on the severity of the damage:

- Surface scratches can generally be repaired by polishing with an automotive rubbing compound.

UPHOLSTERY MAINTENANCE

CAUTION: DO NOT use cleaners such as Lysol®, Armor All®, Windex®, or other abrasive detergents to clean upholstered surfaces. These products will remove moisture from the upholstery, resulting in premature cracking.

Upholstered cushions should be cleaned on a daily basis to prevent damaged due to corrosives found in perspiration. Wipe the top and sides of upholstered cushions using a cloth moistened with a solution of one part lanolin hand cleaner to nine parts water. After cleaning, wipe down using a dry towel to remove any residue.

Owner's Manual
© 2019 All Rights Reserved

SPIRIT