

JB950 JOHNNY G SPIRIT BIKE

OWNER'S MANUAL

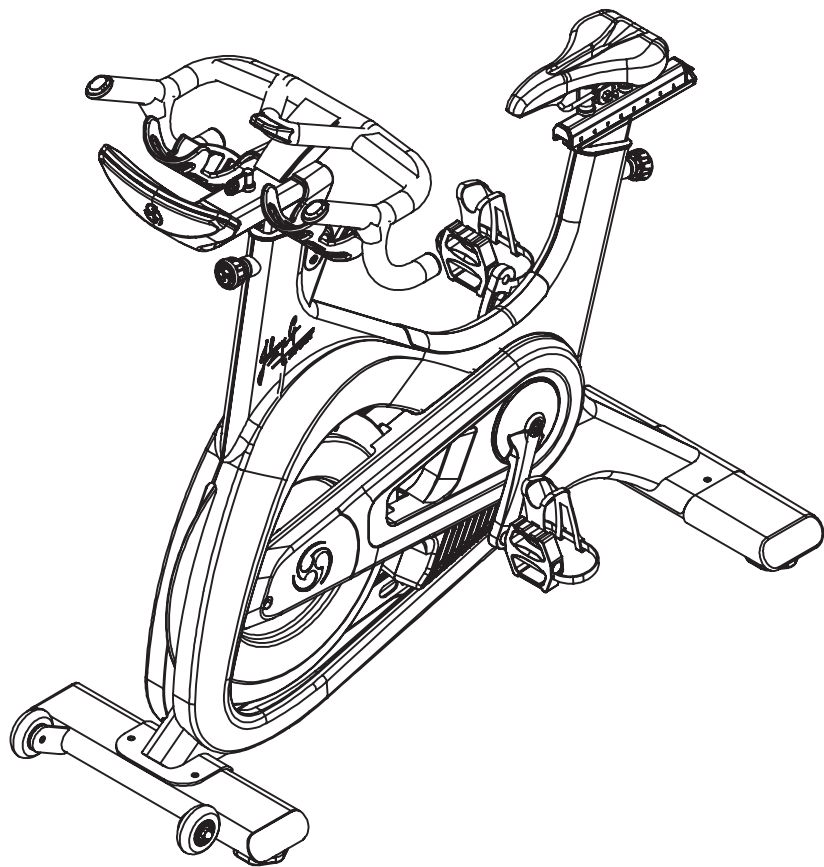

TABLE OF CONTENTS

5	IMPORTANT SAFETY INSTRUCTIONS
15	WARNING LABELS AND COMMUNICATION STICKERS
16	SAFEGUARDS
17	REGISTER YOUR PURCHASE
18	JB950 ASSEMBLY INSTRUCTIONS
25	TESTING THE BIKE
26	INSTRUCTIONS
30	TRAINING INFORMATION
32	CONSOLE OPERATION
36	PROGRAMS
37	PAIR HEART RATE DEVICE
51	MAINTENANCE MODE
66	GENERAL MAINTENANCE
70	CUSTOMER SUPPORT
71	COMMERCIAL WARRANTY

Thank you for purchasing our product, please save these instructions. Please do not perform or attempt any customizing, adjustments, repair or maintenance that is not described in this manual.



Congratulations on your new JB950 Johnny G Spirit Bike and welcome to the Spirit Fitness family!

Thank you for your purchase of this quality JB950 Johnny G Spirit bike from Spirit Fitness. Your new JB950 was manufactured by one of the leading fitness manufacturers in the world and is backed by one of the most comprehensive warranties available. Through your dealer, Spirit Fitness will do all we can to make your ownership experience as pleasant as possible for many years to come. If not purchased direct from Spirit Fitness, the local dealership where you purchased this bike is your administrator for all Spirit Fitness warranty and service needs. Their responsibility is to provide you with the technical knowledge and service personnel to make your experience more informed and any difficulties easier to remedy.

Please take a moment at this time to record the name of the dealer, their telephone number, and the date of purchase below to make any future, needed contact easy. We appreciate your support and we will always remember that you are the reason that we are in business.

Yours in Health,
Spirit Fitness

NAME OF DEALER _____

DEALER PHONE # _____

PURCHASE DATE _____

IMPORTANT SAFETY INSTRUCTIONS

WARNING

This chapter includes precautions and fitness safeguards for the installation and use of the Johnny G Spirit Bike. Please read this chapter carefully before installing or using your equipment. Safety instructions are provided in the following languages (in the order shown):

- English, Dutch, French, German, Italian, Portuguese, Spanish, Swedish, Chinese, Japanese

USER SAFETY PRECAUTIONS

These safety notes are directed to you as the owner of the Johnny G Spirit Bike. Please train all your users and fitness staff to follow these safety instructions. **DO:**

- Do encourage each of your users to discuss their health program or fitness regimen with a healthcare professional.
- Do stop operating your bike if you feel dizzy or faint.
- Do perform regular preventative maintenance.
- Do exercise slowly until you reach a level of comfort.

DO NOT:

- Do not let unsupervised children operate the bike.
- Do not use without proper athletic shoes.
- Do not use in rainy weather outdoors, or in an enclosed pool environment.
- Do not drop or insert any object, hands, or feet into any opening or within the area of the flywheel.
- Do not attempt to remove any shrouds or modify the bike.

WARNING:

- Your Johnny G Spirit Bike is designed for aerobic exercise in a commercial or consumer environment.
- Please check with your physician prior to beginning any exercise program.
- Do not push yourself to excess. Stop if you are feeling faint, dizzy, or exhausted. Use common sense when biking.
- Read the owner's manual in its entirety before operating the bike.
- Failure to obey this warning can result in injury or death.
- Recommended User Weight Limit: 450 lb

SPIRIT FITNESS® and the Spirit Fitness logo are registered trademarks of Dyaco International.

VOORZORGSMAATREGELEN

Deze veiligheidsaantekeningen zijn aan u gericht als eigenaar van de Johnny G Spirit Bike. Gelieve uw gebruikers en uw personeel voor conditietraining volledig bekend te maken met deze veiligheidsinstructies. Doe het volgende:

- Moedig elk van uw gebruikers aan hun gezondheidsprogramma of conditietherapie met een professioneel uit de gezondheidszorg te bespreken.
- Stop het gebruik van uw bike als u zich duizelig of een flauwte voelt.
- Voer regelmatig preventief onderhoud uit.
- Oefen langzaam totdat u een comfortniveau heeft bereikt.
- Gebruik de bike alleen voor zijn bedoelde gebruik, zoals in deze handleiding staat beschreven.

Doe het volgende NIET:

- Laat kinderen zonder toezicht de bike niet bedienen.
- Niet zonder gymschoenen gebruiken.
- Niet buiten bij regenachtig weer gebruiken, of in dichte ruimte met een zwembad.
- Laat geen enkel voorwerp in de bike vallen en steek uw handen of voeten in geen enkele opening van of onder uw bike.
- Probeer geen omhulsels te verwijderen of uw bike te wijzigen.

WAARSCHUWING:

- Uw Johnny G Spirit Bike is ontworpen voor aërobische oefeningen in een commerciële of gebruiker-somgeving.
- Zie uw arts vóór het beginnen van een oefenprogramma.
- Dwing uzelf niet tot buitensporige oefeningen. Stop als u zich duizelig, uitgeput of een flauwte voelt.
- Lees de gebruikershandleiding helemaal en aandachtig door alvorens uw bike te bedienen.
- Nalaten deze waarschuwing op te volgen kan letsel of overlijden tot gevolg hebben.

PRÉCAUTIONS

Ces consignes de sécurité s'adressent aux propriétaires du Johnny G Spirit Bike. Veuillez instruire tous vos utilisateurs et instructeurs à suivre ces consignes. À FAIRE:

- Encouragez tous les utilisateurs à consulter un médecin au sujet de leur programme de fitness ou régime d'exercice.
- Cessez d'utiliser le bike en cas d'étourdissement ou de faiblesse.
- Exécutez régulièrement la maintenance préventive.
- Commencez l'exercice lentement jusqu'à ce que vous atteignez un niveau confortable.
- Utilisez le bike uniquement de la manière prévue, telle que décrite dans ce manuel.

À ÉVITER:

- Ne laissez pas des enfants utiliser le bike sans surveillance.
- Ne l'utilisez pas sans porter de chaussures d'athlétisme.
- Ne l'utilisez pas en extérieur lors de temps pluvieux, ni en intérieur dans une salle de piscine.
- Évitez de laisser tomber tout objet ou d'introduire les mains ou pieds dans toute ouverture ou en-dessous du bike.
- Ne tentez pas de retirer tout carter de protection ni de modifier le bike.

AVERTISSEMENT:

- Le Johnny G Spirit Bike est conçu pour l'exercice aérobique dans un environnement commercial ou privé.
- Veuillez consulter un médecin avant de commencer tout programme d'exercice.
- Ne vous poussez pas au-delà de vos limites. Arrêtez-vous si vous vous sentez faible, étourdi ou épuisé. Faites preuve de bon sens lorsque vous vous entraînez.
- Lisez le guide de l'utilisateur en entier avant d'utiliser le bike.
- Le non-respect de ces avertissements peut se traduire par des blessures, voire la mort.

VORSICHTSMASSNAHMEN

Die folgenden Vorsichtsmaßnahmen richten sich an Sie als Besitzer des Johnny G Spirit Bike. Bitte schulen Sie alle Ihre Benutzer und Ihr Fitness-Personal in der Beachtung dieser Sicherheitsvorschriften. GEBOTE:

- Legen Sie jedem Ihrer Benutzer nahe, sein Gesundheits- oder Fitnessprogramm mit einem medizinischen Fachmann zu besprechen.
- Beenden Sie den Betrieb Ihres bike, wenn Sie sich schwindelig oder schwach fühlen.
- Führen Sie regelmäßige vorbeugende Wartungsmaßnahmen durch.
- Trainieren Sie langsam, bis Sie eine gewisse Komfortzone erreichen.
- Verwenden Sie den bike nur zum vorgesehenen, in dieser Anleitung beschriebenen Zweck.

VERBOTE:

- Lassen Sie den bike nicht von unbeaufsichtigten Kindern in Betrieb nehmen.
- Benutzen Sie das Gerät nicht ohne Sportschuhe.
- Benutzen Sie das Gerät bei regnerischen Witterungsbedingungen nicht im Freien und nicht in einer geschlossenen Schwimmbadumgebung.
- Lassen Sie keine Gegenstände in irgendwelche Öffnungen

oder unter den bike fallen und halten Sie Hände und Füße von diesen Bereichen fern.

- Unternehmen Sie keinen Versuch, irgendwelche Abdeckungen zu entfernen oder den bike zu modifizieren

ACHTUNG:

- Der Johnny G Spirit Bike ist für aerobische Übungen in einer kommerziellen oder Verbraucherumgebung vorgesehen.
- Bitte holen Sie vor Aufnahme eines jeden Trainingsprogramms den Rat Ihres Arztes ein.
- Trainieren Sie nicht übertrieben hart. Hören Sie auf, wenn Sie ein Schwäche-, Schwindel- oder
- Erschöpfungsgefühl verspüren. Lassen Sie sich beim Schrittraining von Ihrer Vernunft leiten. Lesen Sie vor Inbetriebnahme Ihres bike die Bedienungsanleitung vollständig durch.
- Ein Missachten dieses Achtungshinweises kann Verletzungen oder den Tod zur Folge haben.

PRECAUZIONI

Queste note precauzionali sono dirette a voi, come proprietario dello Johnny G Spirit Bike. Siete pregati di istruire i vostri utenti e il vostro personale all'osservanza di queste precauzioni. **DA FARE:**

- Incoraggiate i vostri utenti a discutere il loro programma di salute o di fitness con uno specialista dell'healthcare.
- Interrompete l'uso dello bike se avete giramenti di testa o se vi sentite mancare.
- Eseguite periodicamente servizi di manutenzione.
- Utilizzate lo bike soltanto per l'uso a cui è destinato, come descritto nel manuale.

DA NON FARE:

- Non consentite a bambini di usare lo bike senza la supervisione di un adulto.
- Non utilizzate lo bike senza scarpe atletiche.
- Non utilizzate lo bike all'esterno in condizioni piovose o in un ambiente con piscina interna.
- Non lasciate cadere oggetti sullo bike e non inserite oggetti, mani o piedi in qualsiasi apertura esterna o sotto lo bike.
- Non cercate di rimuovere le coperture o di modificare lo bike.

AVVERTENZE:

- Lo Johnny G Spirit Bike è stato realizzato per esercizi di aerobica in un ambiente pubblico o privato adeguato.
- Prima di iniziare un programma di esercizio fisico, consultate il vostro medico.
- Non eccedete i vostri limiti. Fermatevi se vi sentite mancare, se avete giramenti di testa o se vi sentite esausti. Usate buon senso nell'utilizzo dell'attrezzatura.
- Leggete il Manuale dell'utente interamente prima di utilizzare lo Spinner.
- La mancata osservanza di queste avvertenze può comportare lesioni gravi o morte.

PRECAUÇÕES

Estas notas de segurança destinam-se a você, proprietário do bike Johnny G Spirit Bike. Treine todos os usuários e o pessoal da academia para que sigam estas instruções de segurança. O QUE FAZER:

- Incentive todos os usuários a discutirem seu programa de saúde ou sistema de condicionamento físico com um profissional da área de saúde.
- Pare o funcionamento do bike se sentir tontura ou vertigem.
- Efetue a manutenção preventiva regular.
- Faça exercícios lentamente até atingir um grau de con-forto.
- Use o bike apenas de acordo com a finalidade para que se destina, conforme descrito neste manual.

O QUE NÃO FAZER:

- Não deixe crianças sem supervisão operarem o bike.
- Não use sem os sapatos esportivos apropriados.
- Não utilize em ambientes externos quando o tempo estiver chuvoso, nem em um ambiente fechado de pisci-na interna.
- Não deixe cair nem insira nenhum objeto, mãos ou pés em qualquer abertura ou sob o bike. Não tente remover nenhum degrau nem modificar seu bike.

ADVERTÊNCIA:

- Seu Johnny G Spirit Bike foi projetado para exercícios aeróbicos em um ambiente comercial ou próprio do consumidor.
- Consulte seu médico antes de começar qualquer programa de exercícios.
- Não se esforce demais. Pare se sentir tontura, vertigem ou exaustão. Tenha bom senso ao fazer o exercício. Leia todo o Manual do Proprietário antes de operar o seu bike.
- Deixar de observar esta advertência pode resultar em ferimentos ou morte.

PRECAUCIONES

Estas notas de seguridad están dirigidas a usted como el dueño de Johnny G Spirit Bike. Por favor instruya a todos sus usuarios y personal de entrenamiento para que sigan estas instrucciones de seguridad. **LO QUE SE DEBE HACER:**

- Dígame a cada uno de sus usuarios que discuta su programa de salud o régimen de ejercicio con un profesional de la salud.
- Deje de operar su bike si se siente mareado o como que va a desmayarse.
- Lleve a cabo mantenimiento preventivo a intervalos regulares.
- Haga ejercicio lentamente hasta que alcance un nivel en el que se sienta cómodo.
- Utilice el bike solamente para lo que fue diseñado, como se describe en este manual.

LO QUE NO SE DEBE HACER:

- No permita que los niños operen su bike sin supervisión.
- No lo use sin zapatos atléticos.
- No lo utilice afuera en la lluvia ni en un ambiente cerrado donde haya una piscina.
- No lo deje caer ni inserte objetos, manos o pies en ninguna apertura de su bike ni debajo de él.
- No intente quitar ninguna cubierta o recubrimiento ni modificar su bike.

ADVERTENCIA:

- Su Johnny G Spirit Bike está diseñado para el ejercicio aeróbico en un ambiente comercial o de consumo.
- Por favor consulte con su médico antes de iniciar cualquier programa de ejercicio.
- No haga un esfuerzo excesivo. Deténgase si se siente mareado, exhausto o como si fuera a desmayarse. Use su sentido común al hacer ejercicio.
- Lea completamente el Manual del dueño antes de operar su Spinner.
- El no cumplir con esta advertencia puede resultar en una lesión o en la muerte.

FÖRSIKTIGHETSÅTGÄRDER

Dessa säkerhetsanmärkningar är riktade till dig i egenskap av ägare av Johnny G Spirit Bike manufactured by Spirit Fitness alla användare och all personal att följa dessa säkerhetsanvisningar.

MAN SKA:

- Uppmuntra alla användare att konsultera sitt hälso- program eller sin träningsregim med en läkare.
- Sluta använda bike om man känner sig yr eller svim- färdig.
- Utföra regelbundet underhåll i förebyggande syfte.
- Motionera långsamt tills man når en komfortnivå.
- Endast använda bike för dess avsedda användning, enligt beskrivning i denna handbok.

MAN SKA INTE:

- Låta barn använda bike utan uppsikt.
- Använda bike utan sportskor.
- Använda bike utomhus i fuktigt väder eller i ett innes- lutet bassängområde.
- Tappa in eller föra in något föremål, händer eller fötter i någon öppning, eller under bike.
- Försöka att avlägsna några skyddskåpor eller att modi- fiera bike.

VARNINGAR:

- Din Johnny G Spirit Bike är avsedd för aerobisk träning i kommersiella eller konsumentinriktade miljöer.
- Konsultera din läkare innan du inleder något träningsprogram.
- Driv inte dig själv för hårt. Sluta om du känner dig yr, svimfärdig eller utmattad. Använd Spinner med sunt förnuft. Läs igenom hela handboken innan du använder Spinner.
- Underlåtelse att iaktta dessa varningar kan medföra skada eller dödsfall.

注意事項

下述安全說明適用於您所擁有的 JOHNNY G SPIRIT BIKE 室內健身車。請培訓所有使用者與健身人員遵守下述安全說明。 遵守事項：

- 鼓勵您的每個使用者在使用此健身車前，與專業的醫療保健專業人員討論他們的健康計劃或健身方案。
- 如果您感到頭暈或虛弱，請停止使用此健身車。
- 請定期進行預防性維護。
- 請緩慢且循序漸進使用此健身車，直至達到舒適程度。

禁止事項：

- 請勿讓無人監管的兒童操作此健身車。
- 請勿在沒有穿著合適的運動鞋的狀況下使用此健身車。
- 請勿在戶外陰雨天氣或封閉的泳池環境中使用此健身車。
- 請勿讓任何物體、手或腳掉入或插入任何開口或飛輪區域內。
- 請勿嘗試拆除任何鏈蓋或修改健身車。

警告：

- 您所擁有的 Johnny G Spirit Bike 室內健身車，專為商業或消費環境中的有氧運動而設計。
- 在開始任何鍛煉計劃之前，請諮詢您的醫生。
- 請勿讓自己運動過量。如果你感到昏厥，頭暈或疲憊，請停止使用。使用此健身車時要運用一般常識。
- 在使用此健身車之前，請完整閱讀使用者手冊。
- 不遵守上述警告可能導致人身傷害或死亡。

注意事項

これらの安全に関する注意事項は、JOHNNY G SPIRIT BIKEのオーナーとしてお客様に向け示されています。これらの安全に関する指示や注意事項に従うように、すべてのユーザーやフィットネススタッフをトレーニングしてください。

DO (行ってください) :

- 各ユーザーが各自の健康プログラムやフィットネスプログラムについて、必ず医療従事者や専門家と相談する事を強く奨励します。
- 使用前、使用中にめまいや気分が悪いと感じた場合は、直ちにバイクの使用をやめてエクササイズを中止してください。
- エクササイズバイクの定期的な予防メンテナンスを行ってください。
- 行っているエクササイズが快適に感じるまではゆっくりと運動してください。

DO NOT (行わないでください) :

- 監督なしでの子供の自転車使用を禁止してください。
- 適切な運動靴なしで使用しないでください。
- 雨天時の屋外や屋内プールでの使用は避けてください。

- フライホイールの開口部やその付近に物、手、足、指等を落としたり、入れたり、触れたりしないようにしてください。
- カバーや覆いを取り外したり、このエクササイズバイクを改造しないでください。

警告:

- このJohnny G Spirit Bike社によって製造された、業務使用目的または個人使用目的の有酸素運動用に設計されたエクササイズバイクです。
- エクササイズプログラムを始める前に必ず医師にユーザー自身の健康状態を相談してください。
- 自分自身のレベルを超えた過度なエクササイズは避けてください。わずかでも、体調不良やめまいを感じたり、疲労を感じた場合は直ちにエクササイズを中止して、使用を止めてください。エクササイズバイクの使用には適切な常識を適用する事をお勧めいたします。
- エクササイズバイクを使用する前に、取扱説明書すべてを読み理解してください。
- この警告に従わない場合は、重篤な事故、怪我や死亡に繋がる可能性があります。

SAFEGUARDS

The following fitness safeguards and operating precautions are directed to purchasers and users of the Johnny G Spirit Bike. Club Managers should ensure that members and fitness staff are trained to follow these same instructions. Failure to follow these safeguards may result in injury or serious health risk.

- Ensure that the seat height adjustment knob is properly secured and does not interfere with range of motion during exercise.
- Children under the age of 13 should not ride the bike. The bike mechanism and ergonomics are designed for adult use only.
- Do not insert any object, hands or feet into any openings, or expose hands, arms or feet to the drive mechanism or other potentially moving part of the bike.
- The maximum weight for individuals riding the bike should not exceed 350lbs /159kg.
- Do not dismount the bike until both the pedals and flywheel have stopped completely. Failure to comply may lead to loss of control and serious injury.
- If at any time you feel dizzy or have difficulty breathing, gradually stop pedaling and carefully dismount the bike.
- Listen to your body, ride at a pace that feels right for you.
- Keep children and pets away from the bike whenever it's in use.
- Never turn the pedal crank arms by hand.
- Stay hydrated. Drink water throughout your ride as needed.
- Stay in control by executing all movements at a slow pace before attempting to increase your speed.
- Do not exercise at high speeds and intensity without having initially established a baseline fitness level and obtaining a medical clearance from your physician. Focus on form, posture and establishing a controllable pace before attempting any high intensity short duration sprints.
- Do not use the bike without proper footwear. Never operate the bike with bare feet.
- Never place your feet in any position on the bike other than the pedals.

WARNING LABELS AND COMMUNICATION STICKERS

The following pages show examples of Johnny G Spirit Bike warning labels and communication stickers placed on the equipment as part of the manufacturing process. It is critical that owners maintain the integrity and placement of these stickers. If you find any stickers missing or damaged contact your local dealer or distributor for a replacement. *NOTE: STICKERS AND LABELS ARE NOT SHOWN TO SCALE.*

EXERCISE WARNING DECAL



CALIFORNIA PROP 65 WARNING DECAL
(For US model only)

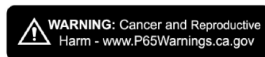

CE CERTIFICATION



SERIAL NUMBER DECAL

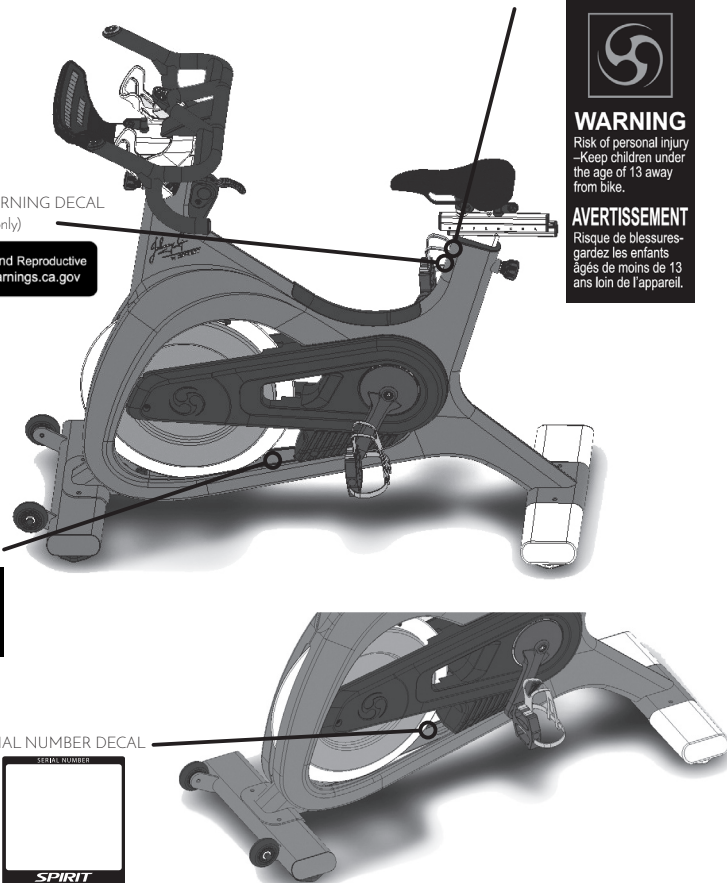

WARNING

This product can expose you to chemicals including Toluene and Acrylamide which are known to the State of California to cause Cancer and birth defects or other reproductive harm. For more information, go to www.P65Warnings.ca.gov

RECORD YOUR SERIAL NUMBER

Please record the serial number of this fitness product in the space provided below (serial number is located on the center floor tube behind the crank.)

Serial Number: _____

REGISTER YOUR PURCHASE

Please mail your warranty registration card to the address below or call us at 800-258-8511 to get your product registered:

Spirit Fitness

PO Box 2037

Jonesboro, AR 72402

United States of America

Patent pending.

JB950 PRE-ASSEMBLY

Use the following procedures to unpack and assemble your Johnny G Spirit Bike:

1. Position the shipping carton so the Heavy End is located at the bottom.
2. Cut the straps then lift the box over the unit and unpack. Remove all parts from the shipping carton and foam inserts, and verify that all parts are included in your shipment.
3. Locate the hardware package. The hardware is separated into four steps. Remove the tools first. Remove the hardware for each step as needed to avoid confusion. The numbers in the instructions that are in parenthesis (#) are the item number from the assembly drawing for reference.
4. Always have assistance when lifting main frame.

NOTE: All tools required to assemble the bike are included within the packaging. If you are missing any of the parts listed above, inspect the packing material and the box for items that may have been overlooked.

If parts are missing, or if you have any operational questions, please call your local Spirit Fitness's Service department or the distributor whom sold you the product. Please see the back of the manual for a listing of international corporate offices and locate the office nearest you. Have your serial number ready.

NOTE: Use the large foam packaging to prop the bike frame off of the ground to allow assembly of the front, then rear stabilizers.

CAUTION: Damage to the bike during assembly is not covered as part of the limited Spirit Fitness warranty. Take care not to drop or lean the bike on its side. Carefully stand the bike up in the normal upright position on a stable surface so it will not tip over during assembly.

Protect the environment by not disposing of this product with household waste. Check your local authority or approved waste center for recycling advice and facilities.

JB950 PRE-ASSEMBLY

TOOLS NEEDED:

- #155. L M4 Allen Wrench (1 pc)
- #157. 17mm Wrench (1 pc)
- #158. 13/15 Wrench (1 pc)
- #159. L M2.5 Allen Wrench (1 pc)
- #167. 19mm Wrench (1 pc)

Use of a large pedal wrench (not included) is highly recommended to secure the pedals.

NOTE: Use the large foam packaging to prop the bike frame off of the ground to allow assembly of the front, then rear stabilizers. ALWAYS have assistance when lifting main frame.

An assembly video is available to show the steps for assembly of the Johnny G Spirit bike. Follow the link below:
http://dyaco.com/JG_Assembly

JB950 STEP ONE

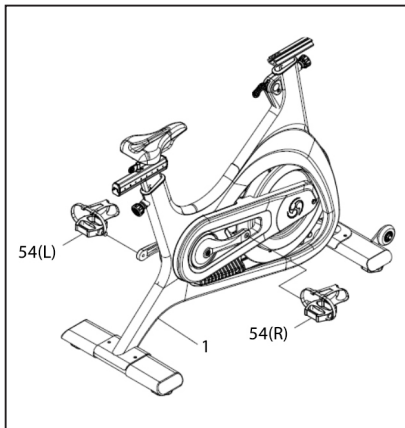
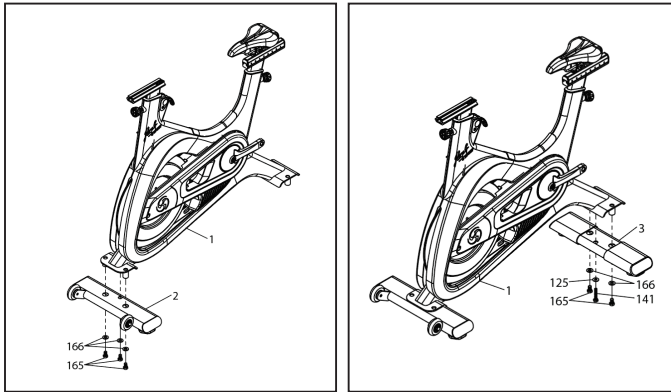

HARDWARE FOR STEP 1			
PART	TYPE	DESCRIPTION	QTY
165	SHORT HEX HEAD BOLT	M12 x P1.25 x 20L	5
141	LONG HEX HEAD BOLT	M10 x P1.5 x 55L	1
166	FLAT WASHER	Ø12.7 x Ø26 x 2T	5
125	FLAT WASHER	Ø10 x Ø25 x 1.5T	1
54	PEDALS SET	PEDALS R/L	1

1. Assemble **FRONT STABILIZER (2)** to **MAIN FRAME (1)** using **THREE HEX BOLTS (165)** and **THREE WASHERS (166)** with **19MM WRENCH (167)**. *NOTE: Use the large foam packaging to prop the bike frame off of the ground to attach the stabilizers.*
2. Assemble **REAR STABILIZER (3)** to **MAIN FRAME (1)** using **TWO SHORT HEX BOLTS (165)**, **ONE LONG HEX BOLT (141)**, **ONE WASHER (125)** and **TWO WASHERS (166)** with **19MM WRENCH (167)**. The **LONG HEX BOLT (141)** and **WASHER (125)** are used in the center hole and tightened with **17MM ALLEN WRENCH (157)**.
3. Assemble **PEDALS (54)** to bike using **15MM WRENCH (158)**. Use of a large pedal wrench (not included) is highly recommended to secure the pedals.

JB950 STEP TWO

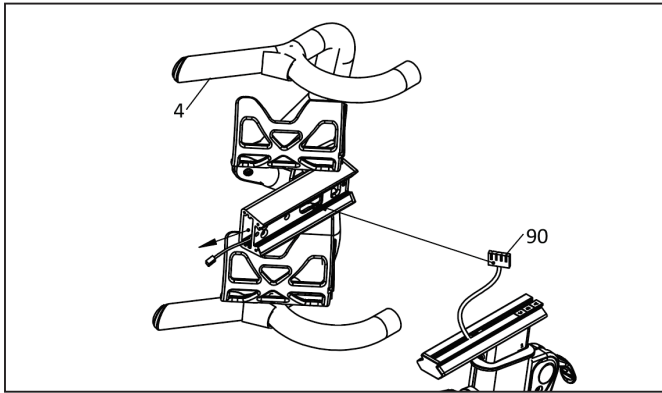

1. Run **MAIN WIRE (90)** through opening at bottom of **HANDLEBARS (4)** and out of the front.
2. Slide **HANDLEBAR ASSEMBLY (4)** onto aluminum slide rail. While assembling, simultaneously pull **MAIN WIRE (90)** out of front to prevent wire from being jammed. Wire connector should protrude from front of handlebars when fully installed.

*NOTE: Be careful not to pinch and damage the **MAIN WIRE (90)** when sliding **HANDLEBAR ASSEMBLY (4)** on to main rail.*

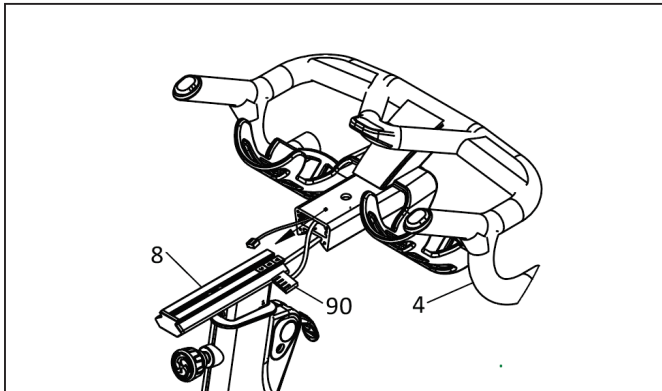

JB950 STEP THREE

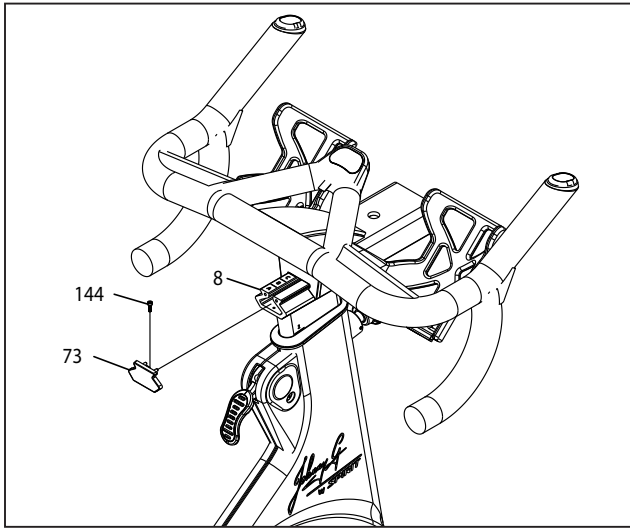

HARDWARE FOR STEP 3			
PART	TYPE	DESCRIPTION	QTY
73	HANDLEBAR END CAP		1
144	SOCKET HEAD CAP BOLT	M3XPO.5X10L	1
51	HANDLEBAR ANCHOR		1

1. Install **HANDLEBAR END CAP (73)** onto back end of **ALUMINUM SLIDE RAIL (8)** and secure with **SOCKET HEAD CAP BOLT (144)** using **2.5 MM ALLEN WRENCH (159)**.
2. The **HANDLEBAR ANCHOR (51)** has been pre-installed into **ALUMINUM SLIDE RAIL (8)**.
3. Using a screwdriver or Allen Key, slide anchor forward to front endcap. Looking through handlebar hole slide handlebar forward to align with screw hole in anchor.

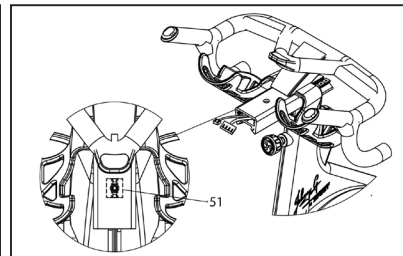
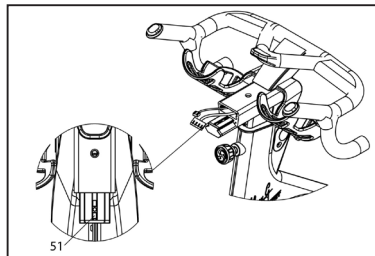
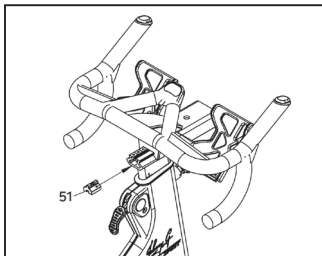

JB950 STEP FOUR

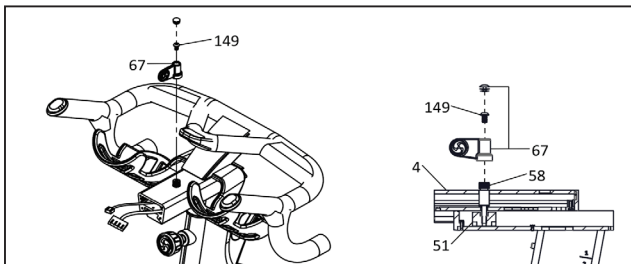
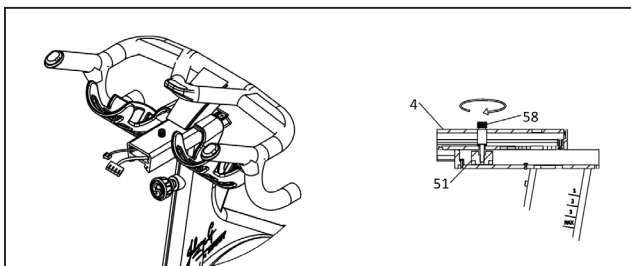
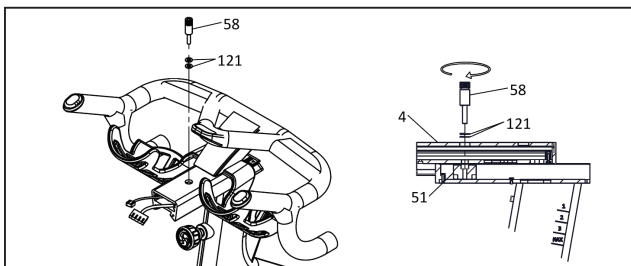

HARDWARE FOR STEP 4			
PART	TYPE	DESCRIPTION	QTY
58	ADJUSTING AXLE		1
67	SOCKET HEAD CAP BOLT	M3xPO.5x10L	1
121	FLAT WASHER	Ø1/4" x 13 x 1.0T	2
149	BUTTON HEAD SOCKET BOLT	M6 x 10L	1

1. Thread **ADJUSTING AXLE (58)** through hole into **HANDLEBAR ANCHOR (51)** with **TWO FLAT WASHERS (121)**. Tighten fully, using **LEVER (67)** as a tool if necessary. *NOTE: Gently pull on MAIN WIRE (90) allowing space for insertion of ADJUSTING AXLE (58) to prevent cable damage.*
2. Insert a small Allen wrench into lever from bottom to remove plastic cap at top of lever allowing access for bolt installation
3. Install **LEVER (67)** in a 12 o'clock position. Attach **LEVER (67)** to **ADJUSTING AXLE (58)** using **BUTTON HEAD SOCKET BOLT (149)** using **4MM ALLEN WRENCH (155)**.
4. Install plastic cap to seal lever.

JB950 STEP FIVE

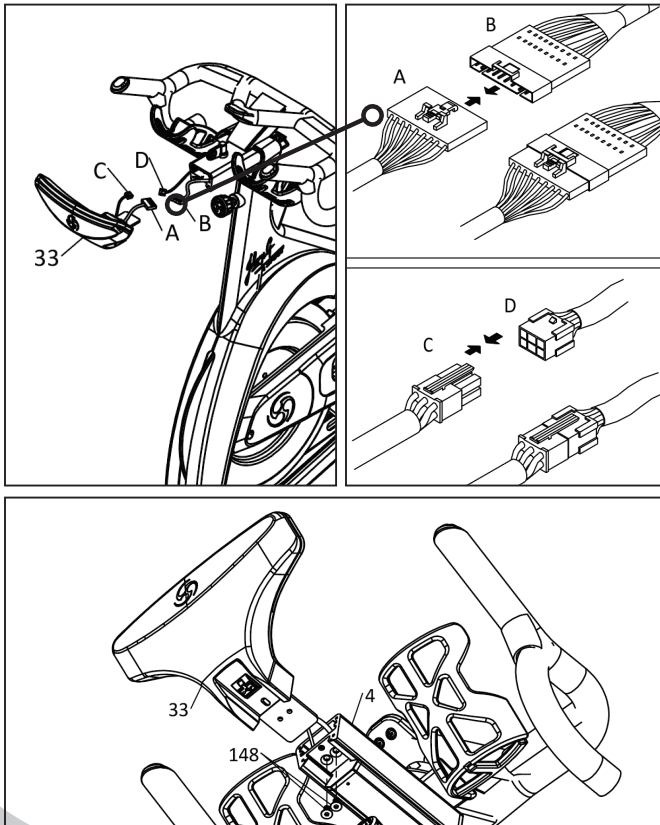

HARDWARE FOR STEP 5			
PART	TYPE	DESCRIPTION	QTY
148	FLAT HEAD COUNTER-SUNK BOT	M6 x P1.0 x 10L	2

1. Connect **MAIN WIRE (A & B)** and **CONTROL WIRE (C & D)** to **CONSOLE (33)**.
2. Attach **CONSOLE (33)** to **ALUMINUM SLIDE RAIL (4)** secure using **TWO FLAT HEAD COUNTERSUNK BOLTS (148)** using **4MM ALLEN WRENCH (155)**.

NOTE: Before pedaling bike, remove Flywheel Shim protecting proper magnet spacing. Locate Shim Hang Tag and pull on cord removing shim. Use shim when needing to transport bikes over long road distances.

TESTING THE BIKE

Use this checklist to perform the bike test procedure.

- Recheck all the bolts and make sure they are all tightened to the proper torque specification (if indicated) and no parts are missing.
- Check the seat to make sure it is level and tight and does not rotate around or tilt. Tighten and adjust as needed.
- Test the seat and handlebar horizontal adjustment for smooth movement front to rear.
- Adjust seat post and handlebar to your needs (refer to page 27). Ride/test the bike for proper operation according to this owner's manual.

CAUTION: Do not dismount the bike until the pedals to come to a complete stop.

- Pedal the bike at a moderate pace and test for proper and smooth movement of the pedals.
- When the testing is complete, tip the bike forward using the arms and roll it on a smooth surface to the final location and adjust the leveling feet so the bike is stable.

INSTRUCTIONS

Your Johnny G Spirit Bike will be an exhilarating indoor cycling experience. The bike allows the user full control over the magnetic resistance by simply pressing on the **+** and **- Keys**, located at two locations; either the Forward Control Pad or the Handlebar Shifters. Providing two resistance adjustment locations was purposely done for the riders' convenience. The Forward Control Pad is ideally positioned for when the rider is in the saddle and hands are in home position or position-one. The Handlebar Shifters are positioned for riders that are out of the saddle and going through tough climbs.

Typically, lower resistance levels enable you to pedal at a faster pace, placing increased demand on the cardiovascular system. Higher resistance levels will typically deliver a greater muscle strength and endurance workout at lower RPM. RPM rates vary dramatically based on the type of ride you are doing (endurance vs. strength). The Johnny G Spirit Bike can display pedal rates up to 150 RPM. If unsure how to properly use the bikes RPM capabilities and resistance system adjustment, seek the help from a qualified indoor cycling instructor or take a class at your local indoor cycling facility as they will teach you how to ride properly and safely.

Additionally, the bike offers seat and handlebar adjustments, allowing the bike to be configured to each users' comfort zone. This section provides the instructions for making seat adjustments, handlebar adjustments, pedal strap adjustments, and for controlling resistance.

NOTE: In a club setting, we recommend each user to initially be properly fitted on the bike by a certified indoor cycling instructor.

SEAT ADJUSTMENTS

Proper bike setup gives you a more comfortable ride and reduces your risk of injury. Proper seat height helps ensure maximum exercise efficiency and comfort, while reducing the risk of injury. Adjust the seat height so that the knee joint is slightly flexed when the extended leg is at the bottom of the pedal stroke. Once the proper height has been achieved, adjust the seat forward or back so that when the feet are in the 3 o'clock and 9 o'clock positions, the forward knee is directly over the pedal axle. Recheck the seat height again after making the fore/aft adjustment, as moving the seat forward and backward can have the same effect as moving it higher or lower.

SEAT HEIGHT

Dismount the bike. Turn the seat height pop-pin counterclockwise and pull out on the pin to release it from its current preset location. Raise or lower the seat to the desired height, then gently release the pop-pin. Raise or lower the seat slightly, if necessary, until the pop-pin engages a preset hole. Turn the pop-pin clockwise to secure. Be sure to tighten firmly. (Figure 1)

FIGURE 1

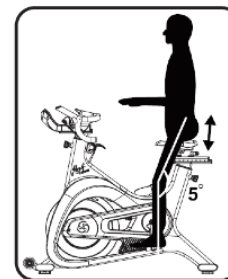
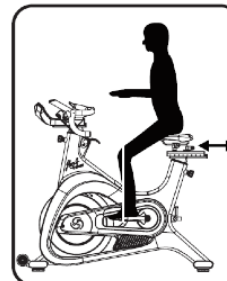

FIGURE 2

FORE/AFT POSITION

Loosen the seat fore-and-aft tension handle by turning the handle counterclockwise. Move the handlebar forward or back to the desired position, then tighten the tension handle by turning clockwise. Be sure to tighten the handle firmly. (Figure 2)



HANDLEBAR ADJUSTMENTS

Position the handlebar at the same height as your seat, or higher if you feel any discomfort in your back. The Johnny G Spirit Bike allows for adjustment of handlebar height. Additionally, the bike allows for fore and aft adjustment of the handlebar.

TO ADJUST THE HANDLEBAR HEIGHT:

Loosen the handlebar height tension handle by turning the handle counterclockwise. Raise or lower the handlebar to the desired height, then tighten the tension handle by turning clockwise. Be sure to tighten firmly (Figure 3).

TO ADJUST THE HANDLEBAR FORE / AFT:

Loosen the handlebar fore-and-aft tension handle by turning the handle counterclockwise. Move the handlebar forward or back to the desired position, and then tighten the tension handle by turning clockwise. Be sure to tighten the handle firmly (Figure 3).

TO ADJUST THE PEDAL STRAPS:

Place the balls of your feet securely in the toe cages, with the ball of the foot (or the widest part of your shoe) over the center of the pedals. As you pedal, concentrate on keeping feet flat, which enables a more powerful pedal stroke. The front of the shoe may not completely fill the toe cage.

NOTE: The pedal straps should be adjusted to hold the foot snugly to the pedal.

FIGURE 3

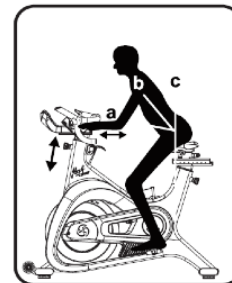

RESISTANCE CONTROL

The bike allows the user full control over the magnetic resistance by simply pressing on the **+** and **- Keys**, located at two locations; either the Forward Control Pad or the Handlebar Shifters. Providing two resistance adjustment locations was done for the riders' convenience. The Forward Control Pad is ideally positioned for when the rider is in the saddle and hands are in home position or position-one. The Handlebar Shifters are positioned for riders that are out of the saddle and going through tough climbs.



RESISTANCE FORWARD CONTROL PANEL



RESISTANCE HANDLEBAR SHIFTERS



DYNAMIC BRAKING HANDLE

NOTE: In case of emergency, you may press directly down on the Dynamic Braking Handle to bring the flywheel to an abrupt stop.

TRAINING INFORMATION

This section will provide very basic information regarding the structure of an indoor cycling workout.

IMPORTANT: User should be aware of the features, functions and proper operation of the bike before using the bike for the first time. If unsure how to properly use the bikes RPM capabilities and resistance system adjustments, seek help from a qualified indoor cycling instructor or take a class at your local indoor cycling facility as they will teach you how to ride properly and safely.

BEFORE BEGINNING

Be sure the seat, handlebar and pedal straps are adjusted for your body size and comfort before beginning your workout. Consult your physician before beginning this or any other exercise routine. Discontinue any exercise that causes you discomfort and consult a medical expert.

WARM-UP

Once you are in position and sitting on the bike with your hands in a comfortable position on the handlebar, slowly begin pedaling. A gradual warm-up prepares the muscles and cardiovascular system for a more intense workout and helps prevent potential injuries from occurring. Your warm-up should be sufficient once your breathing rate begins to increase and you begin to perspire lightly. The warm-up period should last about five minutes.

WORK OUT

A brisk and rhythmic workout will train the muscles and cardiovascular system to perform at a higher efficiency. The key is to exercise aerobically; typically, at 60% – 80% of your maximum heart rate.

COOL-DOWN

Slow and relaxed activity after a workout allows the muscles and cardiovascular system to gradually return to a resting level.

DISMOUNTING BIKE

WARNING: The flywheel momentum of the bike will keep the pedals turning even after the user stops pedaling, or in the event the user's feet slip off the pedals. DO NOT DISMOUNT THE BIKE OR REMOVE YOUR FEET FROM THE PEDALS UNTIL BOTH THE PEDALS AND THE FLYWHEEL HAVE STOPPED COMPLETELY. Failure to comply may lead to loss of control and serious personal injury.

You may stop the bike using any of the following methods:

- Pedal more slowly until the pedals come to a complete stop.
- Push down on the Push Brake System handle until the pedals come to a complete stop.

WORKOUT TRACKING

Your Johnny G Spirit Bike includes both an ANT+ and Bluetooth FTMS chips. Bluetooth FTMS is the new FITNESS Machine Service protocol to control fitness equipment, such as bike trainers, treadmills and rowing machines.

The Johnny G Spirit Bike is compatible with ANT+ and Bluetooth enabled technologies including: Garmin™, MyZone™, and Strava™. Download and connect according to their individual app instructions. The bike also connects with leaderboards such as those from MyZone or Spivi®.



JB950 CONSOLE OPERATION



WARM UP MODE

The **Warm Up Mode** is the most basic function of the Johnny G Spirit Bike. Riders can use this mode to prepare themselves for a class or when just pedaling to warm up for other activities. This mode is the first function that occurs when the console awakens from sleep mode. Riders can stay in this mode for as long as desired.

Upon console awakening, the words *JOHNNY G. METHOD, THE RIDE OF TRUTH* display, then *WARM UP* will flash 3 times, followed by *PRESS PLAY KEY, WHEN READY TO GO*. The Home screen appears displaying *LEVEL, RPM, TIME, DISTANCE, WATTS, HEART RATE*. Console continues Warm Up Mode until **Play Key** is pressed.

The warm up cycle continues until **Play Key** is pressed.

- During **Warm Up** mode, users can adjust level of intensity. Press **+** or **- Key** on either Forward Control Pad or handlebar ends to adjust resistance.
- Warm Up Mode will last as long as user stays in this mode.
- Warm Up Mode will NOT display a summary screen. Only the program screens display a summary.



MANUAL MODE

The **Manual Mode** is another basic function of the Johnny G Spirit Bike. The Manual Mode is also the HR Zone program. Once HR is paired during the Warm Up Mode, HR performance and zones will be tracked. Riders can use this mode for a complete workout or to prepare themselves for other activities. The only differences between this mode and the Warm Up Mode is that the rider will have a workout summary of their effort. At any time during Warm Up Mode, press **Play Key** to enter Manual Mode. Pressing the **Play Key** displays *Enjoy THE RIDE* followed by display screen. Any Time and Distance data collected during Warm Up Mode will be erased.

- Press **+** or **- Key** on either Forward Control Pad or handlebar ends to adjust resistance.
- When ride is completed at desired time, press **Play Key**. Current data will pause.
- Screen displays *END WORKOUT*, then *NO* will flash on display.
- Press either **+** or **- Key** to toggle between *NO* and *YES* for desired action.
- Pressing **Play Key** while *NO* will revert to Manual Mode.
 - Time, Distance, Intensity and data will continue from moment data was paused.
 - *END WORKOUT* function ends the workout.

If selecting *YES*:

- Screen displays *WORKOUT RESULTS*, followed by Summary Data: *TIME* in minutes, *DISTANCE* in miles/km's, *WATT AVG*, *WATT PEAK*, *SPEED AVG* in miles/km's, *SPEED PEAK* in miles/km's, *HR AVG*, *HR PEAK*, *RPM AVG*, *RPM PEAK*.
 - Pressing **+** or **- Keys** will scroll through Summary Data screens.
 - Summary data screens will scroll every 5 seconds if **+** or **- Keys** are NOT pressed.
 - Pressing **Play Key** will reset display and revert to Warm Up Mode.



PROGRAMS

Programs Mode provides the opportunity to pair a HR strap to the console and access to the training programs contained within the Johnny G Spirit Bike.

If just starting a ride and in the Warm Up Mode press and hold the **Play Key** for 3 seconds and the first program option will display, *PAIR HR DEVICE*.

PAIR HR DEVICE is used to pair a HR strap. Once HR strap is paired the HR Zone program will automatically be started. The HR LED light in the lower right of the console will illuminate.

PROGRAMS:

- Pair HR Device
- Power Zone with FTP Test
- Lap Program
- Exit

Descriptions for each of the programs is located on their program page. With the exception of the HR Zone program, the default setting for each program is *OFF* or *DISABLED*. Change their setting to *ON* or *ENABLED*. The HR Zone program has a default setting to *ON*.

PAIR HEART RATE DEVICE

HR Zone program requires connection of a Heart Rate Strap prior to using program. Connecting console to a Heart Rate Strap is accomplished by entering Programs Mode during the Warm Up Mode.

If user puts on a HR strap after leaving the Warm Up Mode and has not paired HR, console reset will be needed.

- While in the Warm Up Mode, press and hold **Play Key** for 3 seconds.
- **PAIR HR DEVICE** displays on console. Press **Play Key** to scan for HR devices. The console may display **SCAN HR DEVICES** up to 12 times.
- If sensors are detected, the number of sensors displays.
- If needed, reset console by simultaneously holding **+ Key** and **Play Key** for 3 seconds.

NOTE: Along with each device displayed is number indicating the distance each device is from the console. The number is in decibels meters and may display as 65DBM. Usually the smaller number is your chest strap but not always. If another rider is wearing a chest strap in front of you, their device may be closer to your console than you are. Ideally rider should be familiar with their MyZone SN# located on the back of the MyZone module or their devices ANT+ number. This will simplify selecting the appropriate HR strap.

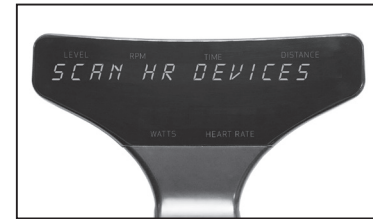

For example: 2 SENSORS FOUND. Press **+ Key** if device shown is not your own.

- MYZONE-12345678 (SN# on your MYZONE device displays).
 - *NOTE: Ideally user should need to be familiar SN # of their MYZONE module, located on the backside.*
- ANT+ 12345 (ID # for your ANT+ device displays).
- After selecting sensor, press **Play Key** to connect heart rate strap to console.
- **ENTER AGE** displays and default age 35 flashes. Press **+ or - Key** to adjust age. Press **Play Key**.
- **MAX HR** displays and estimated max HR flashes. Press **Play Key** to accept.
 - *NOTE: Calculation: $208 - (0.7 \times \text{age}) = \text{MHR}$. Press **+ or - Key** to adjust MHR only if actual is known or wanting to adjust MHR down. Do not adjust up without medical clearance.*
- **WARM UP MODE** flashes 3 times.
- **PRESS PLAY KEY, WHEN READY TO GO** displays on console.
- Console HR LED light illuminates on right side of console.
- See page 40 for full description of HR color zones.

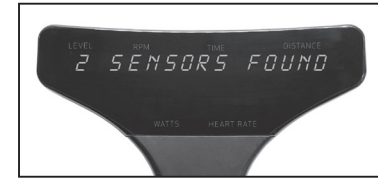
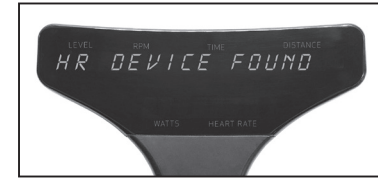

If zero sensors found:

- Re-scan displays.
- Dampen HR contacts on strap if dry.
- Press **Play Key** to re-scan.
- If not wanting to connect a heart rate strap, press **+ Key** until screen displays *DO NOT CONNECT*.
- Press **Play Key** and screen displays *WARM UP*, flashing 3 times, then reverting to Warm Up Mode. The HR on lower display will remain blank.
- After 30 seconds *WARM UP MODE* recycles and flashes 3 times, then continuing with home screen.
- Press **Play Key** when ready to go and begin a ride without HR tracking.



HR ZONE PROGRAM

HR Zone Program estimates your Maximum HR (MHR) when riders' age is entered. The program will track the time spent within the 5 heart rate zones; less than 59% MHR to greater than 90% MHR. The console includes an LED light that will provide a visual guide to the riders' effort. The time spent in each of the HR Zones displays in the workout summary.

Console HR LED color changes based on user percent of max HR (%MHR). The HR LED is on right side of console. HR LED color spectrum is as follows:

- <59% = White
- 60 - 69% = Blue
- 70 - 79% = Green
- 80 - 89% = Yellow
- >90% = Red

To Start:

- Pair HR strap as instructed on page 37.
- Upon pressing **Play Key**, HR Zone Program will begin and *ENJOY THE RIDE* displays followed by home screen.
- Any data collected during Warm Up Mode will be erased.
- Home screen will appear and display: *Level, RPM, Time, Distance, Watts, Heart Rate.*
- Press **+** or **- Key** on either Forward Control Pad or handlebar ends to adjust resistance.

To end workout, refer to instructions on page 41 Ending Ride or User and the workout summary.

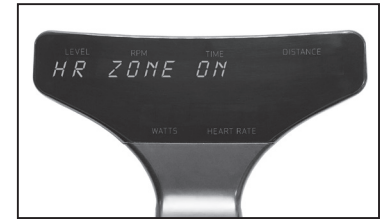

END WORKOUT

To End Ride or User:

- Press and hold **Play Key** for 3 seconds and all current data will pause.
 - Screen displays *END RIDE* or *USER*.
 - Press either **+** or **- Key** to toggle between *END RIDE* and *USER*.
 - Press **Play Key** to select.



If **END RIDE** is selected:

- Screen displays *END WORKOUT*.
- *NO* will flash on display.
- Press either **+** or **- Key** to toggle between *NO* and *YES* for desired action.
- Pressing **Play Key** while *NO* displayed will revert to existing program.

WORKOUT RESULTS:

- Pressing **Play Key** while *YES* displayed will end workout.
- Screen displays *WORKOUT RESULTS*, followed by Summary Data: *TIME* in minutes, *DISTANCE* in miles/km's, *WATT AVG*, *WATT PEAK*, *SPEED AVG* in miles/km's, *SPEED Peak* in miles/km's, *HR AVG*, *HR PEAK*, *RPM AVG*, *RPM PEAK*.
- Pressing **+** or **- Key** will scroll through Summary Data screens.
- Summary Data screens will automatically scroll every 5 seconds if **+** or **- Keys** are NOT pressed.
- Pressing **Play Key** will reset display and revert to Warm Up Mode.

NOTE: If the HR Zone, Power Zone, or LAP program features are enabled for the workout, they will also be shown in the Workout Summary. See those programs for instructions on use. HR Zone, Power Zone or LAP results display after summary data listed above. The number of laps saved in memory for Workout Summary is last 5 laps completed. Time displays in Time window. Distance displays in Distance window.

POWER ZONE: Summary displays percent of total time in each zone.

- Press **Play Key** to display results; press **+ Key** repeatedly to scroll **POWER ZONE** results.
 - WHITE ZONE TIME, PCT
 - BLUE ZONE TIME, PCT
 - GREEN ZONE TIME, PCT
 - YELLOW ZONE TIME, PCT
 - RED ZONE TIME, PCT
- Pressing **Play Key** will revert to **WORKOUT RESULTS** and press **+ Key** to advance to next screen or will happen automatically in 5 seconds.

HR ZONE: Summary displays the percent of time in each zone.

- Press **Play Key** to display results; press **+ Key** repeatedly to scroll **HR ZONE** results.
 - WHITE ZONE TIME, PCT
 - BLUE ZONE TIME, PCT
 - GREEN ZONE TIME, PCT
 - YELLOW ZONE TIME, PCT
 - RED ZONE TIME, PCT
- Pressing **Play Key** will revert to **WORKOUT RESULTS**. Press **+ Key** again to advance and repeat screens.
- Pressing **Play Key** will reset display and revert to **WARM UP** Mode.

LAP PROGRAM: Summary displays time and distance for each lap.

- LAP 1, LAP 2, LAP 3, LAP 4, LAP 5 Time and Distance.
 - If no laps were recorded this screen will not display.
 - Only the last 5 laps will display on separate screens, if recorded.

If **USER** is selected:

The User function adds another program to run concurrently. The console is capable of running All three programs at the same time. The User feature is used to accomplish this. Once leaving the Warm Up Mode, if the **Play Key** is pressed for 3 seconds while in any program, *END RIDE* or *USER* will display; from there any program can be ended or started.

- Press **Play Key** and if HR is paired then *DISCONNECT HR* will display.
- Press **+ Key** to scroll through programs: *POWER ZONE*, *LAP*.
- Use the **+ Key** and **Play Key** to activate or disable each of the programs.
 - Refer to each of the programs pages for instructions.

NOTE: Because USER function is activated after leaving Warm Up Mode, programs will not start with a Warm Up. HR can ONLY be paired during Warm Up Mode. If HR is not already paired, then USER function cannot activate HR. Console reset is required.

- **Power Zone:** USER function can turn ON or OFF program.
- **FTP Test:** USER function can be used to access and run FTP tests inside the Power Zone program.
- **LAP Program:** USER function can enable or disable program.
- Reset the console by pressing simultaneously and holding **+ Key** and **Play Key** for 3 seconds. This action will revert to Warm Up Mode.

POWER ZONE PROGRAM

The **Power Zone Program** takes a riders Functional Threshold Power or FTP in watts and track their performance across 5 training zones; less than 55% FTP to greater than 106% FTP. The console includes an LED light that will provide a visual guide to the riders' effort. The time spent in each of the FTP Zones displays in the workout summary. Console can also administer an FTP test.

To start:

- If just beginning a riding session and HR strap has not been paired, refer to page 37 for pairing HR and passing the Warm Up Mode into the HR Zone program.
- Use the USER function as instructed on page 43 to access the Power Zone program.
- **POWER ZONE OFF** or **ON** displays. Press **+ Key** to display **POWER ZONE ON**. Power zone LED illuminates on lower left of console. Press **Play Key**.
- **ENTER FTP** displays and 150W flashes.
 - Press **+ or - Key** to adjust FTP if actual is known up to 500.
 - Users can enter their FTP or perform FTP test. (The default FTP level is 150W)
- Press **Play Key**.
- **RUN FTP TEST** displays and **NO** flashes. Press either **+ or - Key** to toggle between **NO** and **YES** for desired action.
- If **NO**, Upon pressing **Play Key**, Power Zone Program will begin.
- Home screen will appear and display: Level, RPM, Time, Distance, Watts, Heart Rate.
- Press **+ or - Key** on either Forward Control Pad or handlebar ends to adjust resistance.

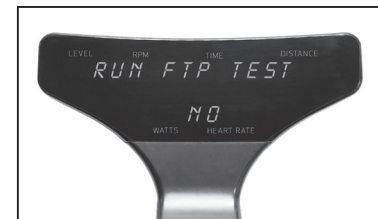
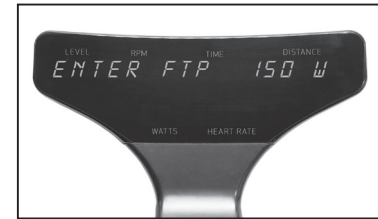
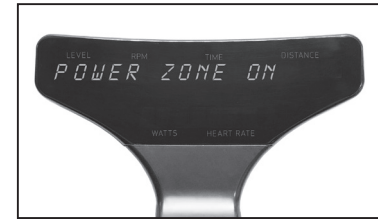

Console Power Zone LED color changes based on user percent of max FTP. Console Power LED is on left side of console. Power Zone LED color spectrum is as follows:

- <55% FTP = White
- 56 - 75% FTP = Blue
- 76 - 90% FTP = Green
- 91 - 105% FTP = Yellow
- >106% FTP = Red

Press **+** or **- Key** on either Forward Control Pad or handlebar ends to adjust resistance. To end workout, refer to instructions on Ending Ride or User and the workout summary on page 41.

NOTE: Power Zone Program requires the use of users Functional Threshold Power or FTP in watts. If user does not have an FTP, console can administer FTP test. See FTP TEST for instructions.

FTP TEST

A thorough warm-up is important for a successful and accurate FTP test. Use Warm Up Mode for a minimum 5 minutes of steady pedaling and intervals prior to starting FTP test. If user needs to establish their FTP, console can administer FTP test. During set-up process:

- Enter Power Zone program as instructed on page 44.
- *ENTER FTP* displays and 150W flashes.
 - Press **+** or **- Key** to adjust FTP if actual is known.
 - Users can enter their FTP or perform FTP test.
- Press **Play Key**.
- *RUN FTP TEST* displays and *NO* flashes.
- Press either **+** or **- Key** to toggle to *YES*. Press **Play Key**.
- *FTP TEST* displays and *5 MIN* flashes. Press either **+** or **- Key** to toggle between a 5- and 20-min test.
 - User can take either 5- or 20-MIN FTP test. A 20-minute test is a better measure of a user's FTP, however if choosing 5-minute test because of time constraints, attempt test again later for repeatability of the results.
- Press **Play Key**.
- *WARM UP* displays and 0.30 seconds counts down.
- *GO* Displays for 3 seconds.
- FTP test begins. and test time counts down.
- Press **+** or **- Key** on either Forward Control Pad or handlebar ends to adjust resistance.

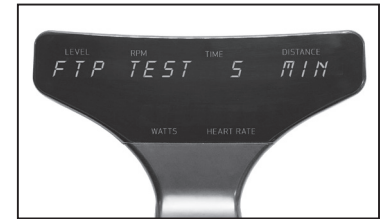
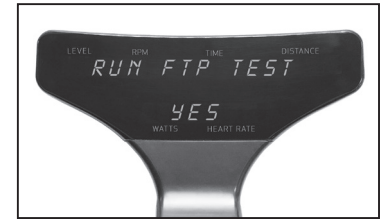

NOTE: Ideal pacing is a steady and consistent effort throughout the duration, where the average power for the first half is also the same as the average power for the second half. Listen to your body. Aim for a watt target that can be sustained.

Test will continue until completed or until ended by pressing the **Play Key**.

- If test terminated early, console displays *TEST ENDED EARLY* then reverts to *FTP TEST*.
- If test is completed, console displays *TEST COMPLETED* with FTP watts value displayed.
 - FTP score after test = 95% of Average Watts during test.
 - Press **Play Key** to return to Power Zone Program with FTP score entered program.
- If desired, reset the console by pressing simultaneously and holding **+ Key** and **Play Key** for 3 seconds. This action will exit rider from Power Program and revert to warm up.



To end workout, refer to instructions on page 41 on Ending Ride or User and the workout summary.

LAP PROGRAM

The **Lap Program** allows riders to perform repeated measures of Time and Distance efforts. The program will compare your current lap with your previous lap. Rider may perform as many laps as desired, but only the last 5 laps will display in the workout results.

To start:

- If just beginning a riding session and HR strap has not been paired, refer to page 37 for pairing HR and passing the Warm Up Mode into the HR Zone program.
- Use the USER function as instructed on page 43 to access the LAP program.
 - Press **+** **Key** to *ENABLE*.
 - *ENABLED* setting is required for Lap Program to run and for lap results to display in workout summary.
- Press and hold **Play Key** for 3 seconds to activate the LAP Program
- Home screen will appear and display: *LEVEL, RPM, TIME, DISTANCE, WATTS, HEART RATE*.
- Press **+** or **- Key** on either Forward Control Pad or handlebar ends to adjust resistance.
- Until **Play Key** is pressed to start a lap, the rider will remain in a Recovery Mode.

To start lap:

- At desired time of Recovery Mode, press **Play Key**.
- *THIS.LAP* displays on lower section of console, replacing Watts and Heart Rate.
- The *TIME* display will reset to 0.00.
- The *DISTANCE* display will reset to 0.00.
- Lap is being recorded.

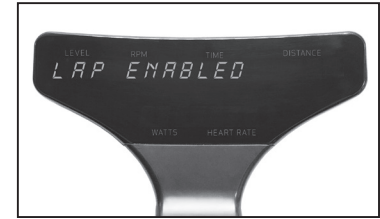

To end lap:

- Press **Play Key** again and display temporarily goes away with *END LAP* displayed on lower section of console.
- Display shows *TIME* and *DISTANCE* paused and *THIS.LAP*.
- After 5 seconds, full display returns with total accumulated Time and Distance from beginning of program. Watts and Heart Rate returns to display.
- Lap has been recorded.
- At this point rider is in a recovery phase prior to beginning another lap or ending ride.



Next lap:

- If **Play Key** is pressed again, the cycle described above will repeat.
- *THIS.LAP* displays on lower section of console
- The *TIME* display will reset to 0.00.
- The *DISTANCE* display will reset to 0.00.
- After 5 seconds, *LAST.LAP* appears, flashing 3 times.
 - Total time and distance will display from previous lap.
 - Words *LAST.LAP* will flash. Display will show *LAST.LAP* for 3 seconds, then back to *THIS.LAP* for 5 seconds.
- Cycle will repeat until Play Key is pressed, *END LAP* briefly displays, then *THIS.LAP* data displays for 5 seconds, then *LAST.LAP* for 5 seconds, then console exits to recovery mode and total workout information displays.
- User may continue using lap function, but number of laps saved in memory for display during workout summary is the last 5 laps completed.



To end the LAP Program and view workout results, refer to page 41 for complete instructions on ending workout.

- Press and hold **Play Key** for 3 seconds and all current data will pause.
- Screen displays *END RIDE* or *USER* with *END RIDE* flashing.
- Press **Play Key** to select.
- Screen displays *END WORKOUT*.
- *NO* will flash on display.
- Press either **+** or **- Key** to toggle between *NO* and *YES* for desired action.



MAINTENANCE MODE

Maintenance Mode contains sensitive settings for your bike's console. Becoming familiar with the Maintenance Mode information used in this section important for your bike's proper operation. It is necessary that the console be powered in order to access the Maintenance Mode. Pedaling above 30RPM is all that is needed to illuminate the console. Maintenance Mode offers following bike settings:

- Key Test
- Display Test
- Odometer
- Units - English/Metric
- Brake Test
- RPM Sensor
- Update Software
- LED Brightness
- ANT+ ID Setup
- Auto Detect HR
- HR Zone
- FTP Test 5 Min
- Demo Mode
- Calibration
- Software Version
- Exit

ENTERING MAINTENANCE MODE

It will be necessary for light to moderate pedaling of bike to power on the console, enter Maintenance Mode and change the settings.

- Simultaneously press and hold **+ Key**, **- Key** and **Play Key** on Forward Control Pad for 3 seconds.
- Console displays *MAINTENANCE MODE*.

Upon entering Maintenance Mode:

- Press **Play Key**.
- *KEY TEST* displays on console.
- Press the **+ Key** to scroll through different screens until the desired screen displays.
- Press **Play Key** to enter displayed setting.
 - Once within setting, use **+** or **- Key** adjust.
 - Press **Play Key** to confirm and exit some but not all settings.
 - Press the **+ Key** to scroll through to another screen.
- Exit Maintenance Mode by resetting console.
 - Press **Play Key** and **+ Key** simultaneously for 3 seconds. *CONSOLE RESET* displays on console.

KEYTEST

The purpose of this setting is to ensure that each of the buttons are signaling properly.

- Press **Play Key** to enter setting.
- Press **Play Key** and follow console direction *PRESS ALL KEYS*.
- There are 5 buttons that control the bike:
 - Forward Control Panel: **+ Key** , **- Key** and **Play Key**.
 - Handlebar Ends: **Right Side + Key**, **Left Side - Key**.
- *TEST PASSED* displays if all keys are communicating properly.
- System will revert to setting screen.
- Press **+ Key** for next screen or reset console to exit Maintenance Mode.

DISPLAYTEST

The purpose of this setting is to ensure that each of the 23 LED Panels are fully functional.

- Press **Play Key** to enter setting.
- All sections of each of the 23 LED panels will illuminate.
- Press **Play Key** to turn off.
- Press **Play Key** again.
 - All LED panels will illuminate the #1, then automatically cycle from #1 - 9 and A - Z.
 - LED color lights for HR Zone and Power Zone cycle through colors.
- Display will turn off then will revert to setting screen.
- Press **+ Key** for next screen or reset console to exit Maintenance Mode.

ODOMETER

The purpose of this setting is to track the number of hours bike has been in use.

- System will automatically display *ODOMETER HRS*.
- *HOLD PLAY TO RESET* appears.
- To reset **Odometer**, press and hold **Play Key**.
 - It is useful to keep track of bike usage for routine maintenance considerations.
 - It is useful when considering moving bike around in studio to even usage.
- System will revert to setting screen.
- Press **+ Key** for next screen or reset console to exit Maintenance Mode.

UNITS

The purpose of this setting is to change from ENGLISH (Imperial) to METRIC distance calculation.

- Press **Play Key** to change setting.
- Default setting is *ENGLISH*.
 - *SPD AVG* and *SPD PEAK* in workout results will only display MPH.
- Press **+ Key** for next screen or reset console to exit Maintenance Mode.

BRAKE TEST

Brake test controls are a sensitive setting for your bike's functionality. Proper training is required for this setting. The purpose of this setting is to test the magnetic resistance system.

- Press **Play Key** to enter Brake Test. *MOTOR TEST AUTO* is displayed.
 - Press **+ Key** or **- Key** to switch to Motor Manual and Limit Sensor and Exit.
- Press **Play Key**.
- *LEVEL TO 20* displays, Press **Play Key**.
 - Auto-run motor in a look from L-1 to L-20 and back to L-1.
 - Press **Play Key** to end, revert to *BRAKE TEST*.

MOTOR TEST MANUAL

- Use **+ Key** and **- Key** to move motor.
- Press **Play Key** to end, revert to *BRAKE TEST*.
 - *ENCODER* displays. This is Encoder count or digital value. Upper right of display displays *LIMIT SENSOR CONDITION*.
 - 1 = HOME
 - 2 = ACTIVE RANGE
 - 3 = END
 - Lower display displays *ENCODER SET VALUE*.
 - To exit, Console Reset is required.
 - Press Play Key and + Key simultaneously for 3 seconds. *CONSOLE RESET* displays on console.

LIMIT SENSOR

Limit Sensor tests for the proper movement of the flag the moves between the home sensor (S1) and the limit sensor (S2). This test is performed only when motor error has occurred.

- S1 OFF, S2 OFF, bottom number is encoder wheel count (0)
- Using the **+** and **- Keys**, adjust the motor to try and change S1 to ON.
- Pedaling resistance should change as keys are pressed.
- If S1 ON, stop pedaling immediately, allow console to turn off and let stand for 15 minutes minimum for memory to clear before trying bike.
- EXIT will revert to setting screen.
- Press **+ Key** for next screen or reset console to exit Maintenance Mode.

RPM SENSOR TEST

RPM Sensor controls a sensitive setting for your bike's functionality. Proper training is required for this setting. The purpose of this setting is to test the functionality of the RPM detection system.

- Press **Play Key** to enter RPM Sensor Test.
 - REED ON RPM displays *ON* or *OFF*.
 - When REED switch is closed, displays *ON*.
 - When REED switch is open, displays *OFF*.
 - RPM displays *PEDAL RPM*.
- Press **Play Key** to exit to setting screen.
- Press **+ Key** for next screen or reset console to exit Maintenance Mode.

UPDATE SOFTWARE

The purpose of this setting is to update console software with the use of a USB inserted into a port underneath the console. Updating software requires a Blank USB memory stick and a computer to transfer updates from service website or e-mail from customer service, to USB, to console. No other material besides the updates should be in USB drive.

- Insert the USB drive.
- Press **Play Key** to display BOOTLOADER - OFF.
- Press **+ or - Key** to switch to BOOTLOADER - ON.
- Press **Play Key** to advance out of software update.
- Reset Console by Pressing Play Key and + Key simultaneously for 3 seconds.
- *CONSOLE RESET* displays on console
 - If successful, displays UPDATE DONE (flashing)
 - If unsuccessful, displays SEARCH UPDATE or UPDATE FAIL, check USB for proper insertion and re-attempt.
- Console will reset with JOHNNY G METHOD flashing
- Remove the USB stick

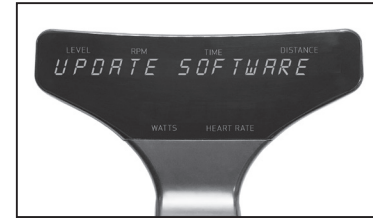

LED BRIGHTNESS

The purpose of this setting is to change the brightness of the display.

- Press **Play Key** to change setting.
- Default brightness setting is 2.
- Press **+ Key** or **- Key** switch between LED Brightness 1, 2, or 3.
- Press **Play Key** to accept and exit to setting screen.
- Press **+ Key** for next screen or reset console to exit Maintenance Mode.

ANT+ ID SETUP

The purpose of this setting is allowing numbering of the bike when using a Leaderboard software, such as Spivi® or similar.

- Press **Play Key** to change setting.
- Console will display *ANT+ ID SETUP*, and 1 on the lower console flashing.
- Press **+ Key** or **- Key** to adjust the bike number to the desired number. Over 1,000 are available. Set each bike to a unique number. The number must be set to 1 or above, 0 is not a valid number.
- Press **Play Key** to accept, bike number will stop flashing momentarily then turn off indicating set.
- Press **+ Key** for next screen or reset console to exit Maintenance Mode.

AUTO PAIR HR

The purpose of this setting is to turn ON or OFF the HR pairing function during the Warm Up Mode. Not all cycling classes are done using HR. Facilities have the option to simplify the user set-up and facilitate getting into the Manual Mode where HR tracking is not used. The default setting is OFF.

When OFF, pairing HR can only be done using the PAIR HR DEVICE function within the Programs Mode.

- Press **Play Key** to change setting.
- Default HR pairing setting is *OFF*.
- Press **+ or - Key** switch *OFF* and *ON*.
- Press **Play Key** to accept and exit to setting screen.
- Press **+ Key** for next screen or reset console to exit Maintenance Mode.

HR ZONE

The purpose of this setting is to turn ON or OFF the HR Zone LED light when a HR strap is paired. A facility may choose to deactivate this light if it were a distraction or against their class structure. If a HR strap is paired, the console maintains tracking of HR training performance regardless of the LED lights activation. The default setting is ON.

- Press **Play Key** to change setting.
- Default HR pairing setting is *ON*.
- Press **Play Key** to change between *ON* and *OFF*.
- Press **+ Key** for next screen or reset console to exit Maintenance Mode.

FTP TEST 5 MIN

The purpose of this setting allow for the changing of the coefficient used for the 5- minute FTP Test. Some testers use a coefficient of 85% in determining the watts level result for the 5-Min FTP Test. Others suggest it should be 80%. We have the ability to change the coefficient depending on the setting. The default setting is 80%.

- Press **Play Key** to change setting.
- Default 5-Min FTP is 80%.
- The coefficient will display as 80 PCT with 80 flashing.
- Press **+ or - Key** to change between 80% and 85%.
- Press **Play Key** to accept and exit to setting screen.
- Press **+ Key** for next screen or reset console to exit Maintenance Mode.

DEMO MODE

For the console to continually display *DEMO MODE*, a plug-in cord would be required that can connect with the bikes electrical board. This setting is primarily used for manufacturer Trade Shows and requires access to electricity. The purpose of this setting is allowing the console to display.

- Press **Play Key** to enter *DEMO MODE* and the following display in a loop:
 - *JOHNNY G. METHOD*
 - *THE RIDE OF TRUTH*
 - *ENJOY THE RIDE*
- Press **Play Key** to exit to setting screen.
- Press **+ Key** for next screen or reset console to exit Maintenance Mode.

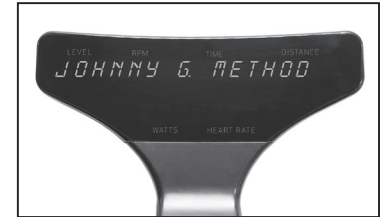

SOFTWARE VERSION

The purpose of this setting display the current version of software contained in the console. Knowing the version is necessary for customer service when providing software updates.

- Press Play Key to view the software version.
- Press Play Key to exit to setting screen.
- Press + Key for next screen or reset console to exit Maintenance Mode.

CALIBRATION

Calibration contains factory-sensitive settings for the bike's resistance system. Do not enter and make adjustments as they will negatively affect the bike's resistance profile.

EXIT

Pressing *EXIT* will automatically end Maintenance Mode, reset the console and flash JOHNNY G. The console is ready for a new ride.

FUNCTIONAL THRESHOLD POWER

Power/Watts - What is it?

It has been said that from a coaching perspective the Watt is the measurement of truth: why is this?

Because you either can perform at a set wattage at a given time or you can't, the response is instant. For the coach and athlete this is very useful as it provides unequivocal feedback of what has been performed in terms of intensity, duration and total workload. This adds a level of precision to workouts not otherwise possible with other metrics such as heart rate or RPE. Power provides an objective measure of progress and is an excellent indication of fitness.

Functional Threshold Power (FTP): Functional Threshold Power is one of the key factors of your power cycling armory but what is it? It's generally agreed that FTP is the maximal power output that can be sustained for the duration of one hour, the classic time trial.

This is why FTP is important. We know that the exercise intensity at which lactate begins to accumulate - the lactate threshold (LT) - is a powerful predictor of endurance ability, this is because although cardiovascular fitness, i.e., maximal oxygen uptake (VO₂max) sets the upper limit to the rate of aerobic energy production, it is the metabolic fitness indicated, LT, that determines the percentage of VO₂max that can be utilized for a given period of time. Consequently, LT - especially when expressed as a power output, is the single most important physiological determinant of performance. This therefore provides a physiologically sound basis around which to design power meter-based training programs.

How Do We Measure FTP?

There are several ways to test riders FTP but the two most commonly employed by riders is the 20-minute test and the other being much shorter at 5 minutes. Each of these has a high correlation to the 60-minute test but were developed for practical reasons of time and ability of most individuals.

20-minute Functional Threshold Power Protocol*

- 20 minutes easy warm-up
- 3 x 1-minute speed bursts with a minute rest between (100 RPM pedal cadence)
- 5 minutes easy
- 5 minutes all out (hard at first, but not so hard that you can't complete the effort)
- 10 minutes easy
- 20-minute steady max effort (this is the test – like the previous 5-minute all-out effort, keep in control, hard but steady)
- 10 to 15-minute cooldown

5-minute Functional Threshold Power Protocol:

- 20 minutes easy warm-up
- 3 x 1-minute speed bursts with a minute rest between (100 RPM pedal cadence)
- 5 minutes easy
- 5 minutes all out (this is the test so go hard at first, but not so hard that you can't complete the effort)
- 10 to 15-minute cool-down

* *Training and Racing with a Power Meter: Allen and Coggan, 2nd Ed 2010.*

FTP and Zones: Zones, be it in Heart rate or describing energy systems, can mislead people in to thinking that the levels are compartmentalized into set and discrete physiological responses. It must be emphasized that there is a sliding continuum that blends across one level to the next. There is no physiological 'switch' from one level to the next but a sliding scale of effort across the identified training outcomes. The reason we use zones is that it offers coaches a framework for understanding, to develop a structure for sustained improvement. A simple way to remember it in relation to time is: "the harder you do it, the less time you can do it for".

POWER TRAINING LEVELS

Basis for the System/Number of Levels

The industry standard has been set at 5 levels as that was felt to be the optimum number needed to represent the range of physiological responses and to describe the different types of training required/used to meet the demands of fitness-based cycling. These zones are a guide only and are used alongside other information related to an individual's fitness capacity and specific goal-based training program.

The table shown below lists the primary physiological adaptations expected to result from training at each level, although these will obviously be influenced by factors such as the initial fitness of the individual, the duration of each workout, the time taken between each interval effort, etc.

ZONE	FTP%	ASSOCIATED HEALTH AND FITNESS BENEFITS
Red	106 - >150%	Threshold Zone - Red Line zone Improved VO ₂ threshold and higher lactate tolerance ability.
Yellow	91-105%	Aerobic Zone or the Transition Zone - Shifting ratio of fuel Benefits: improved functional capacity, increases number and size of blood vessels, respiratory rate, max pulmonary ventilation, pulmonary diffusion, increase in difference in arterial - oxygen, increase in size and strength of heart.
Green	76-90%	The Temperate Zone or Recovery Zone Benefits: healthy heart, fat mobilization by moving fat from cell, fat to muscle, increase of mitochondria, increase of fat release from fat cell.
Blue	56-75%	Healthy Heart Zone - Easiest and most comfortable 'working' zone Benefits: lowered blood pressure, lowered cholesterol, and decreased risk of degenerative diseases.
White	<55%	Starting zone, also used for complete recovery Basic physiological changes linked to 'warming up', 'warming down' and recovery.

Power is a useful tool for the following reasons:

- It correctly evaluates training sessions to avoid misinterpretation.
- It verifies the workouts have been executed correctly.
- It evaluates training status and performance.
- It enables training load, overload and progression to be monitored.
- It allows the design of appropriate number and length of intervals in training.
- It helps decide and structure a race strategy or training session based on an athlete's strengths.

HR and Power are the two portions of that equation: what is being produced and at what cost to our body. Both are equally important to assess performance. If we only measure the body's response using a heart rate monitor and have no gauge of the output, then we are limited in how to determine changes in fitness. Having output-measuring devices such as a power meter gives a lot of options for workouts and, essentially, makes every workout a test of fitness progress.

The ratio of HR/Power is a good indicator of fitness and progression in a training program. In a well-structured, progressive and appropriate training program this ratio should get smaller, that is a lower HR for the same power output. The caveat here is of course that the Heart Rate values being used to evaluate what is an adequate output response are founded on an as accurate as possible personally tested Max Heart Rate and Max Threshold Heart Rate to allow for the correct identification of the relevant working zones.

The leading authors in the field of Power and its application to cycling are coaches such as Andrew Coggan, Hunter Allen, Joe Friel, Chris Carmichael, and Allen Lim. These authors have led the way in developing complex algorithms, software and websites to make training with power a simple method for the cyclists and the coach. It is their successful utilization of Power for training cycling professionals that has led the way. If you have an urgent need to get deep in to the science linked to the subject then the Internet will bring up many fascinating articles when you enter any of the names mentioned above, they are the leading authorities in pro riding with power.

GENERAL MAINTENANCE

A regular preventative maintenance schedule with all fitness equipment ensures that products are working at an optimal condition without affecting the end user exercise experience. To assist in the maintenance regiment, it is recommended to break service into: Daily, Weekly, & Monthly activities. Details on each activity can be found in the Maintenance section of this document.

TOOLS

Working on this product will require basic and/or sometimes specialty tools based on the type of service that will be performed at any time. To assist, Spirit Fitness recommends having the tools listed (Fig. 1) available when performing maintenance.

FIGURE 1

TOOLS	PURPOSE
Crank Puller	Removing crank.
Metric Allen (Hex Key) Wrench Set	Tightening or removing various Allen head screws throughout the product.
Metric Sockets Set	Tightening or removing various hex nuts used throughout the product.
Metric Open Wrench Set	Tightening or removing various hex nuts used throughout the product.
Square Drive Ratcheted Wrenches	To use in conjunction with Allen head and or hex socket sets.
Torque Wrench	Tightening various critical bolts throughout the product to specific torque specifications.
Phillips Head Screwdriver Set	Tightening or removing various Phillips head screws used throughout the product.

MOVING & LEVELING

To move the bike to a new location: Lift the bike from the rear and use the front wheels (located on the front leg, below the handlebar) to roll the bike from one location to another.

To level the bike: Use the four leveling adjusters (located on the underside of the front and rear legs) to compensate for uneven floor surfaces.

PREVENTIVE MAINTENANCE

Perform regular scheduled preventive maintenance procedures to maintain your Johnny G Spirit Bike bike in serviceable condition.

DAILY MAINTENANCE

The life of your product will be determined by how consistently you perform the daily maintenance procedures. Dry the Johnny G bike after each use to remove sweat and moisture. It is best to use a liquid non-abrasive cleaner diluted with water.

Wipe Down/Cleaning: To prevent the build-up of rust and other forms of corrosion, wipe down the bike at the end of each day (or preferably at the end of each class). Raise all posts to the highest setting to expose moisture. Using an absorbent cloth, focus on all areas that perspiration can settle. Give attention to the following areas:

- Handgrips
- Seat / adjustable slide for the seat
- Back leg assembly
- Guard
- Pop-pins
- Leveling feet

NOTE: Never use abrasive cleaning liquids or petroleum-based solvents when wiping down the bike.

WEEKLY MAINTENANCE

Weekly maintenance should focus on the overall performance of your Johnny G Spirit Bike. During these inspections, look for vibration and possible loose assemblies. Have an experienced rider ride each bike to identify and help diagnose any vibration, noises, and any "unusual" feeling from the drive belt. Either faulty flywheel alignment or a loose belt can cause vibration. Check for proper flywheel alignment. If flywheel requires adjustment refer maintenance to a properly trained service tech. Inspect each bike for loose assemblies, parts, bolts and nuts. Give attention to the following:

- Tighten all frame base hardware.
- Tighten all pop-pin handles.
- Tighten seat hardware.
- Tighten pedal toe clip/toe straps.

MONTHLY MAINTENANCE

The monthly maintenance check should be a comprehensive inspection of the overall frame and main assembly components of the Johnny G Spirit Bike in addition to the Weekly Maintenance.

INSPECTION AND ADJUSTMENT

Inspect major moving parts that require constant proper torque. Loose or misadjusted parts can result in personal injury or damage to the bike. Check the following parts for security and/or proper torque.

Pedals: Verify that the pedals are re-torqued after the first 10 hours of use and every 100 hours of operation, thereafter. Use a torque wrench if components are loose. **IMPORTANT:** It is not recommended that members change out the pedals on the bike.

FRAME CARE

It is recommended that the frame on the bike is sealed from sweat impurities that may speed the corrosion process at least once a month.

Cleaning: Using a clean terry cloth that is dampened in 30 parts water to 1 part non-abrasive detergent or car wash soap rub over the frame of the product.

Wash/Dry: Dampen a clean terry cloth in an only water solution to wipe away any soap residue. Using a second clean and dry terry cloth; dry off any liquid residue.

Sealing: The frame can be sealed by applying a wax or polishing coat that can help repel away liquids like human perspiration. Apply the wax or polish per the manufacturer's instructions for best results.

SANITIZING YOUR SPIRIT FITNESS EQUIPMENT

- Unupholstered high-contact surfaces (hard plastics) can be sanitized using a 75% isopropyl alcohol solution and a clean, dry cloth. Spray surfaces to be sanitized, and use the dry cloth to wipe clean. Allow surfaces to dry before using.
- For upholstered or soft-plastic surfaces, use a conditioner after sanitizing. Be sure to follow the instructions provided by the conditioner manufacturer to ensure proper use of the conditioner.
- Alternatively, you can make your own spray by mixing the proper ratio of isopropyl alcohol and distilled water to reach a 75% solution.
- For more details on sanitization, or to learn how to make your own spray solution, please visit <https://support.spiritfitness.com/hc/en-us/articles/4406787148564> .

PARTS REPLACEMENT

Depending on the use and maintenance of the product, certain items may need to be replaced upon inspection due to wear. These can be identified during scheduled inspections as described in the Preventative Maintenance section of this owner's manual beginning on page 66.

CUSTOMER SUPPORT

For international customers, please contact your local distributor.

JB950 JOHNNY G SPIRIT BIKE WARRANTY EFFECTIVE NOVEMBER 19, 2021

Spirit Fitness warrants the Johnny G Spirit Bike for a period of time listed below from the date of retail sale, as determined by sale receipt, or in the absence of a sales receipt eighteen (18) months from the original factory shipping date. Spirit Fitness' responsibilities include providing new or remanufactured parts, at Spirit Fitness' option, and technical support to our independent dealers and servicing organizations. In the absence of a dealer or service organization, these warranties will be administered by Spirit Fitness directly to a consumer. The warranty period applies to the following components.

Warranty	Frame	Electronics	Parts	Labor
Commercial	10 Years	2 Years	2 Years	1 Year

*Prisons and correctional facilities are excluded from warranty coverage.

NORMAL RESPONSIBILITIES OF THE OWNER

The owner is responsible for the items listed below:

- Proper use of the fitness equipment in accordance with the instructions provided in this manual.
- Proper installation in accordance with instructions provided with the fitness equipment.
- Expenses for making the fitness equipment accessible for servicing, including any item that was not part of the fitness equipment at the time it was shipped from the factory.
- Damages to the fitness equipment finish during shipping, installation or following installation.
- Routine maintenance of this unit as specified in this manual.

EXCLUSIONS

This warranty does not cover the following:

1. CONSEQUENTIAL, COLLATERAL, OR INCIDENTAL DAMAGES SUCH AS PROPERTY DAMAGE AND INCIDENTAL EXPENSES RESULTING FROM ANY BREACH OF THIS WRITTEN OR ANY IMPLIED WARRANTY. Note: Some states do not allow the exclusion or limitation of incidental or consequential damages, so this limitation or exclusion may not apply to you.
2. Service call reimbursement to the consumer. Service call reimbursement to the dealer that does not involve malfunction or defects in workmanship or material, for units that are beyond the warranty period, for units that are beyond the service call reimbursement period, or for fitness equipment not requiring component replacement.
3. Damages caused by services performed by persons other than authorized Spirit Fitness service companies; use of parts other than original Spirit Fitness parts; or external causes such as corrosion, discoloration of paint or plastic, alterations, modifications, abuse, misuse, accident, improper maintenance, inadequate power supply, or acts of God.
4. Products with original serial numbers that have been removed or altered.
5. Products that have been: sold, transferred, bartered, or given to a third party.
6. Spirit Fitness reserves the right to request proof of purchase if no warranty record exists for the product.
7. THIS WARRANTY IS EXPRESSLY IN LIEU OF ALL OTHER WARRANTIES EXPRESSED OR IMPLIED, INCLUDING THE WARRANTIES OF MERCHANTABILITY AND/OR FITNESS FOR A PARTICULAR PURPOSE.

CUSTOMER SUPPORT

If any items need replacement contact the Spirit Fitness Customer Support Department at 1-800-258-8511. For international customers, please contact your local distributor.

SERVICE

- Keep your bill of sale. Twelve (12) months from the date on the bill of sale or eighteen (18) months from the date of factory shipping as determined by the serial number establishes the labor warranty period should service be required. If service is performed, it is in your best interest to obtain and keep all receipts. This written warranty gives you specific legal rights. You may also have other rights that vary from state to state within the United States. Service under this warranty must be obtained by following these steps, in order:
- Contact your selling authorized Spirit Fitness dealer. OR
- Contact your local authorized Spirit Fitness service organization.
- If there is a question as to where to obtain service, contact our service department at (866) 463-2662. For international customers, please contact your local distributor.
- Spirit Fitness' obligation under this warranty is limited to repairing or replacing, at Spirit Fitness' option, the product through one of our authorized service centers. All repairs must be preauthorized by Spirit Fitness. If the product is shipped to a service center freight charges to and from the service center will be the customer's responsibility. For replacement parts shipped while the product is under warranty, the customer will be responsible for shipping and handling charges. For in-home service, the customer will be responsible for a trip charge. There will be an additional trip charge if the customer is located over 100 miles from the nearest service center.
- The owner is responsible for adequate packaging upon return to Spirit Fitness. Spirit Fitness is not responsible for damages in shipping. Make all freight damage claims with the appropriate freight carrier. **DO NOT SHIP ANY UNIT TO OUR FACTORY WITHOUT A RETURN AUTHORIZATION NUMBER.** All units arriving without a return authorization number will be refused.
- For any further information, or to contact our service department by mail, send your correspondence to:

Spirit Fitness
PO Box 2037
Jonesboro, AR 72402

Product features or specifications as described or illustrated are subject to change without notice. All warranties are made by Spirit Manufacturing, Inc. This warranty applies only in the 48 contiguous United States. NOTE: This does not apply to Alaska or Hawaii.

MANUFACTURER

Spirit Fitness

3000 Nestle Road
Jonesboro, AR 72401
TEL: +1 870 935 1107
EMAIL: spiritservice@spiritfitness.com

INTERNATIONAL OFFICES

Taipei HQ Office

12F, No.111, Songjiang
Rd. Taipei City, Taiwan, 10486
TEL: +886-2-2515-2288
FAX: +886-2-2515-9963
EMAIL: info@dyaco.com

Dyaco Japan

Ryogoku ST Bldg. 7F 2-17-17
Ryogoku Sumida Tokyo 130-0026, Japan
TEL: +81 3-5669-0405
FAX: +81 3-5669-0406
EMAIL: info@dyacojapan.co.jp

Dyaco Shanghai

Room 210, No.350
Hengren Road

Yangpu District
Shanghai, China 200438
TEL: 86-21-65068300
FAX: 86-21-65068150

Dyaco UK Ltd

Fairbourne Drive
Atterbury
Milton Keynes
MK10 9RG UK
TEL: +44-0-800 029 3865
EMAIL: sales@dyaco.co.uk

Dyaco Germany

Technologiepark Bergisch-Gladbach
Haus 56
Friedrich-Ebert-Straße 75
51429 Bergisch Gladbach
TEL: +49-0-2204 844 340
FAX: + 49-0-2204 844 333
EMAIL: info@dyaco.de

Dyaco Canada

5955 Don Murie Street
Niagara Falls, ON

L2G 0A9
Canada
TEL: +1 888-707-1880
FAX: +1 905-353-8968
EMAIL: sales@dyaco.ca



800.258.4555
spiritservice@spiritfitness.com
www.spiritfitness.com



Spirit Fitness
3000 Nestle Road
Jonesboro, AR 72401



JB950 Owners Manual
© 2021 All Rights Reserved
Revision: 04.21.2022