

PRIMAL

STRENGTH

PRIMAL STRENGTH V3 HOME RACK WITH DIP AND LANDMINE

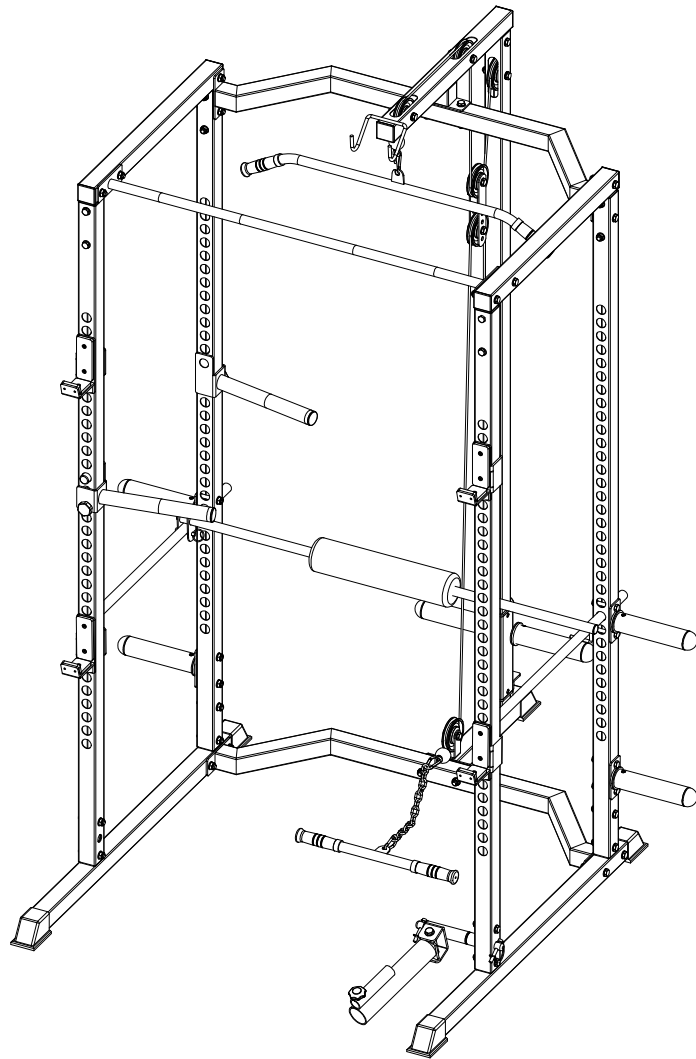





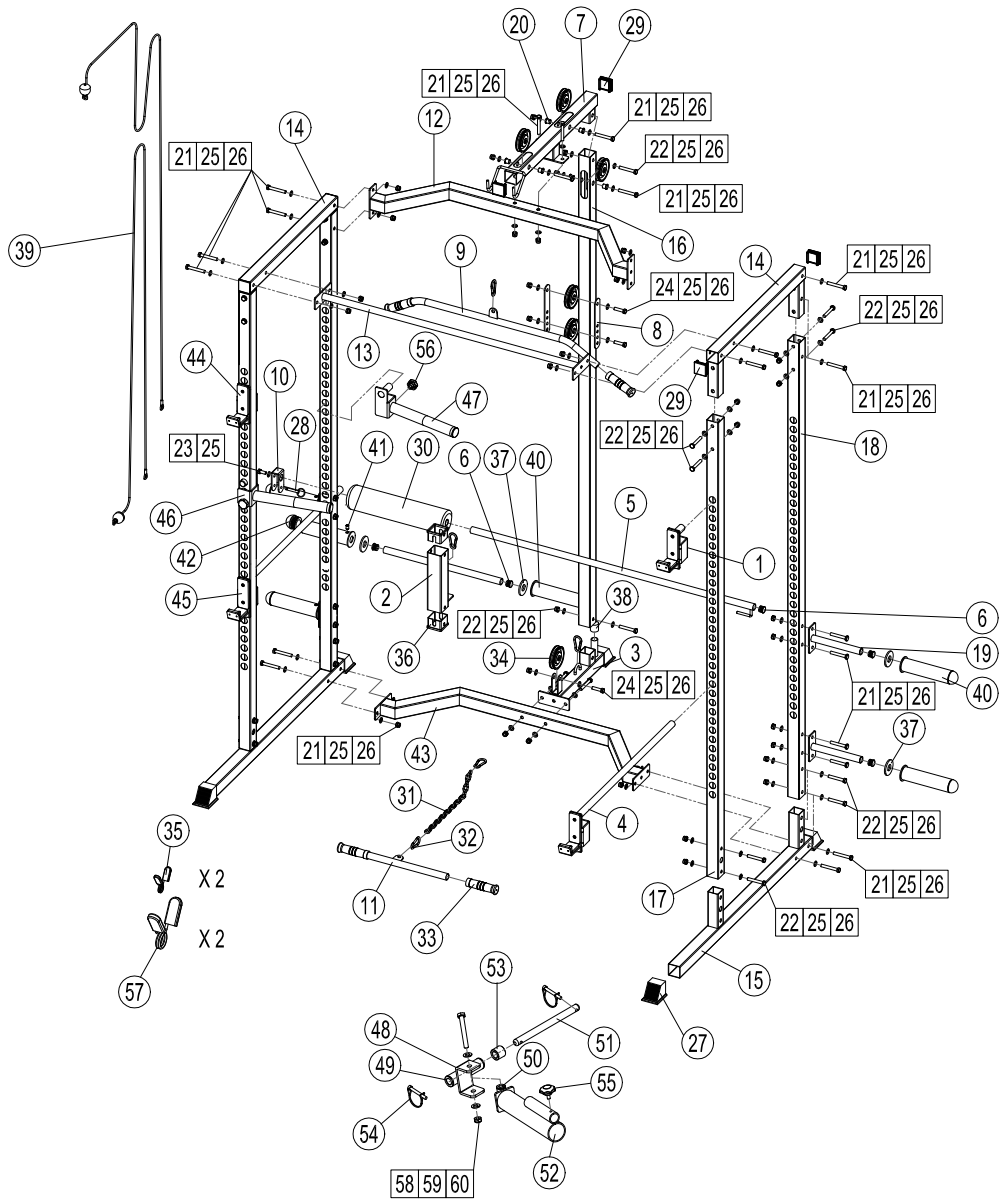



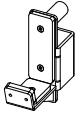
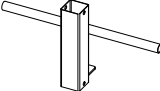
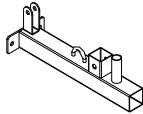
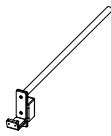
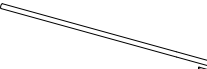

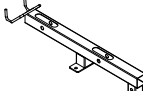
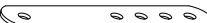
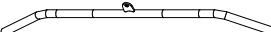
ASSEMBLY INSTRUCTIONS

EXPLODED DIAGRAM

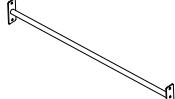

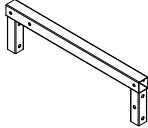
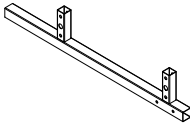
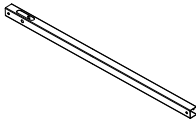
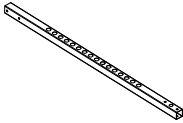
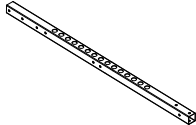
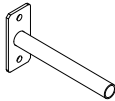

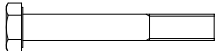
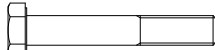
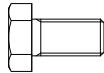
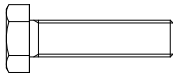
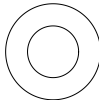
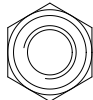

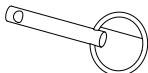

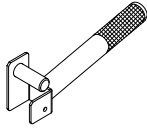
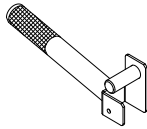

PART LIST

NUMBER	DESCRIPTION		QUANTITY
1	LEFT SHORT SAFELY BAR		1
2	PLATE CARRIAGE LOADED		1
3	LOWER BEAM		1
4	LEFT LONGER SAFELY BAR		1
5	FOAM ROLLER BAR SUPPORT		1
6	TUBE PLUG		7
7	TOP BEAM		1
8	PULLEY BRACE		2
9	LAT BAR		1
10	CLAMPING PLATE		1
11	LOW T BAR		1
12	REAR CROSS BEAM		1
13	CHROME PULL UP BAR		1

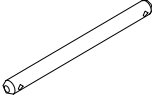
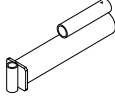

14	UPPER CROSS FRAME		2
15	BOTTOM BASE FRAME		2
16	LAT PULL SHAFT		1
17	FRONT UORIGHT FRAME		2
18	REAR UPRIGHT FRAME		2
19	PLATE STORAGE		4
20	16 PULLEY SLEEVE		6
21	BOLT M10*70		19
22	BOLT M10*65		26
23	BOLT M10*20		1
24	BOLT M10*40		3
25	WASHER 10		89
26	LOCK NUT M10		48
27	FOOT COVER		5
28	8*35 LOCKING BOLT		1

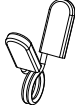
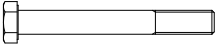
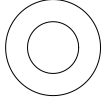
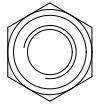
29	50*50 TUBE PLUG		6
30	FOAM ROLLER		1
31	40CM CHAIN LINK		1
32	GROUND BUCKLE		5
33	25 HANDER		4
34	90 PULLEY		6
35	25MM STANDARD SPRING COLLAR		2
36	60*50 PLASTIC TUBE BUSHING		2
37	BUFFER WASHER		6
38	25 RUBBER TUBE CUP		1
39	30*80 CABLES		1
40	OLYMPIC ADAPTER		6
41	HEXAGON SOCKET SET SCREW M10*10		6
42	ROUND PLUG		6
43	CROSS BEAM		1
44	RIGHT SHORT SAFETY BAR		1
45	RIGHT LONGER SAFETY BAR		1

46	LEFT HANDLE SUPPORT		1
47	RIGHT HANDLE SUPPORT		1
48	ROTANTION SUPPORT		1
49	COPPER BUSHING		2
50	SMALL COPPER BUSHING		2
51	AXIS		1
52	BAR SUPPORT		1
53	NYLON WASHER		1
54	LOCK PIN		2
55	PLUM SHAPED SCREW		1
56	HEXAGON SHAPED SCREW		2
57	55MM STANDARD SPRING COLLAR		2
58	BOLT M12*100		1
59	WASHER 12		2
60	LUCK NUT M12		1

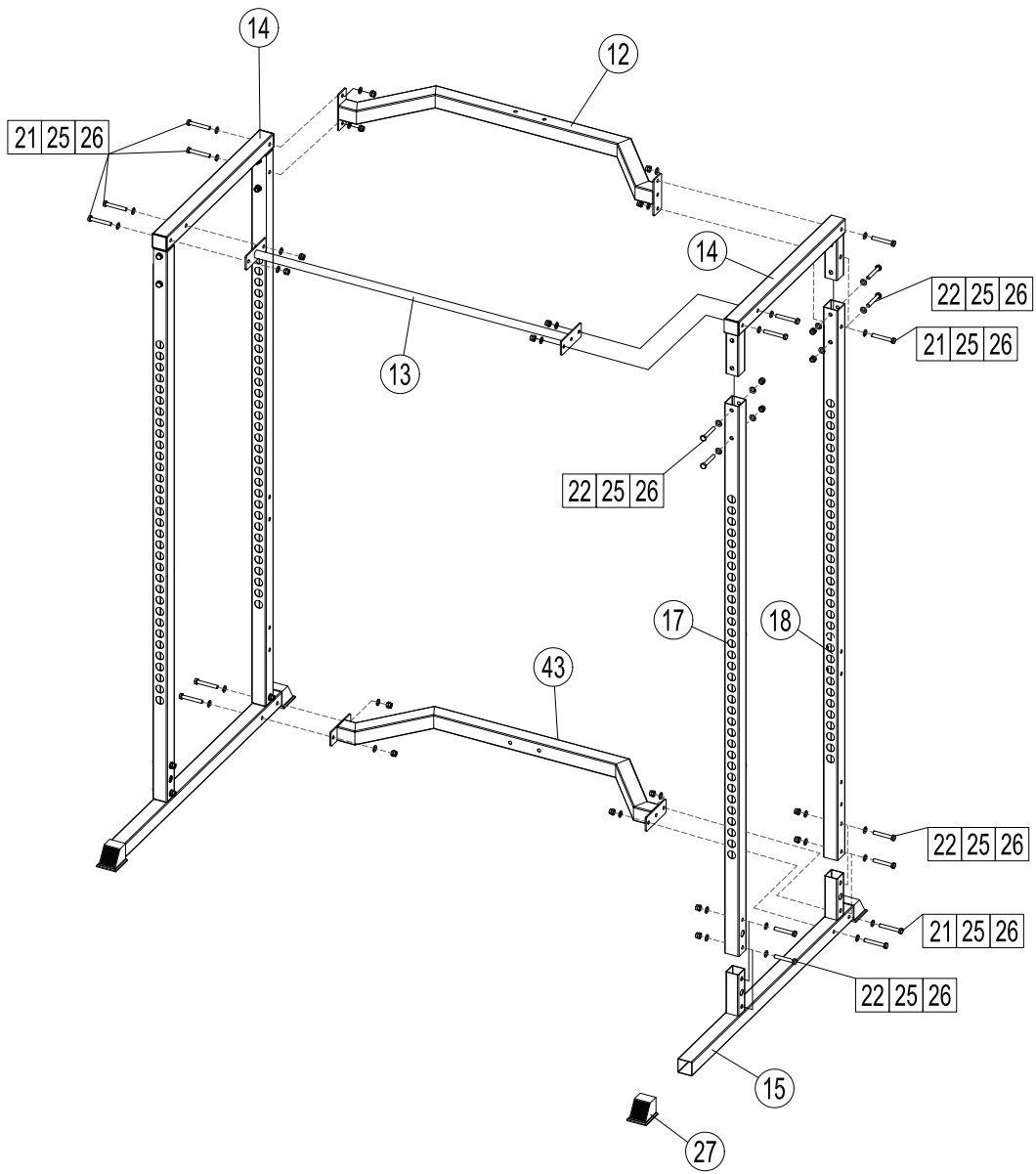

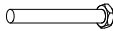
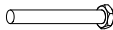

STEP 01

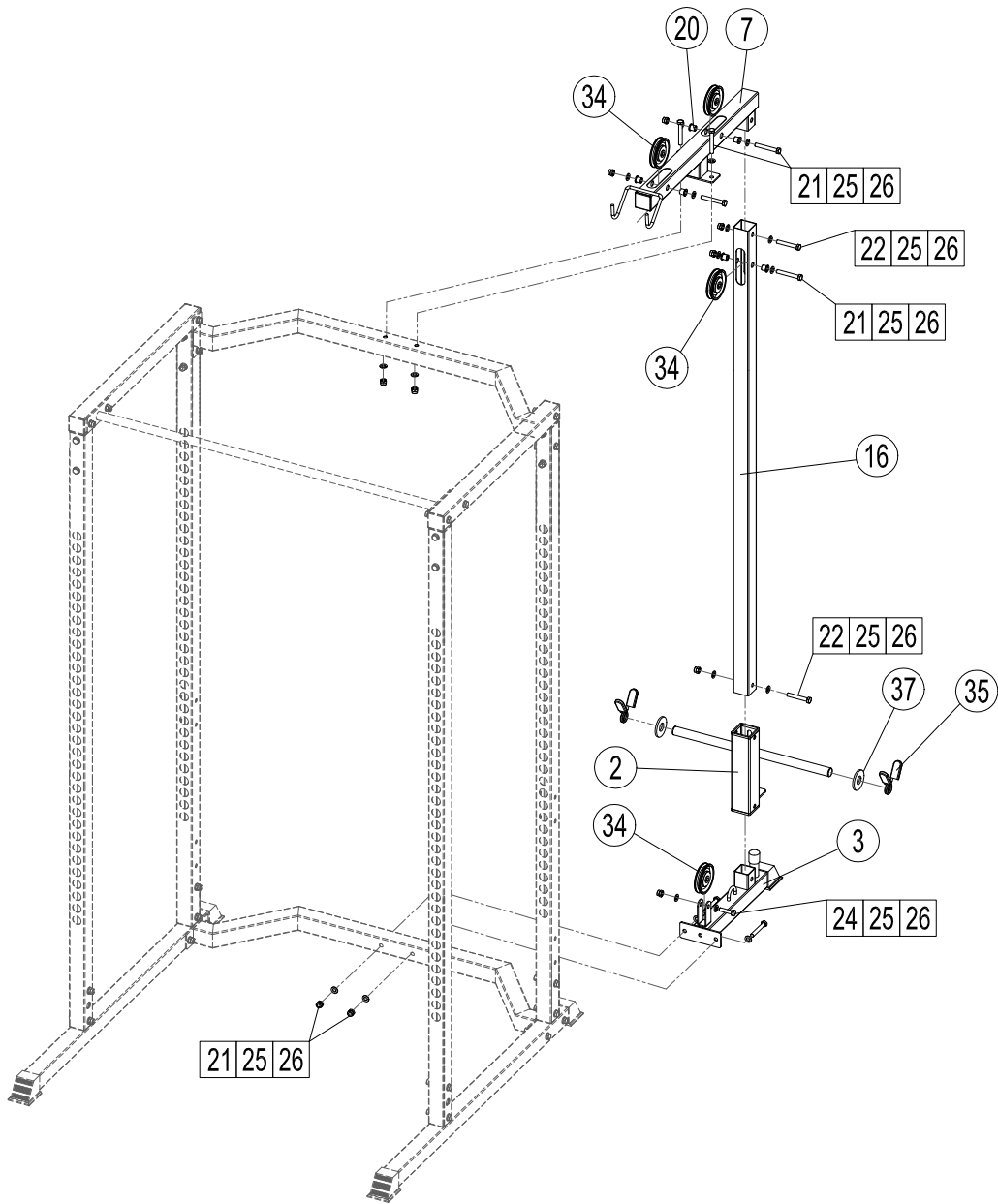

21#		M10*70	Qty:12
22#		M10*65	Qty:16
25#		10	Qty:56
26#		M10	Qty:28

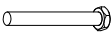
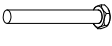

STEP 02



21#		M10*70	Qty:7
22#		M10*65	Qty:2
24#		M10*40	Qty:1
25#		10	Qty:20
26#		M10	Qty:10

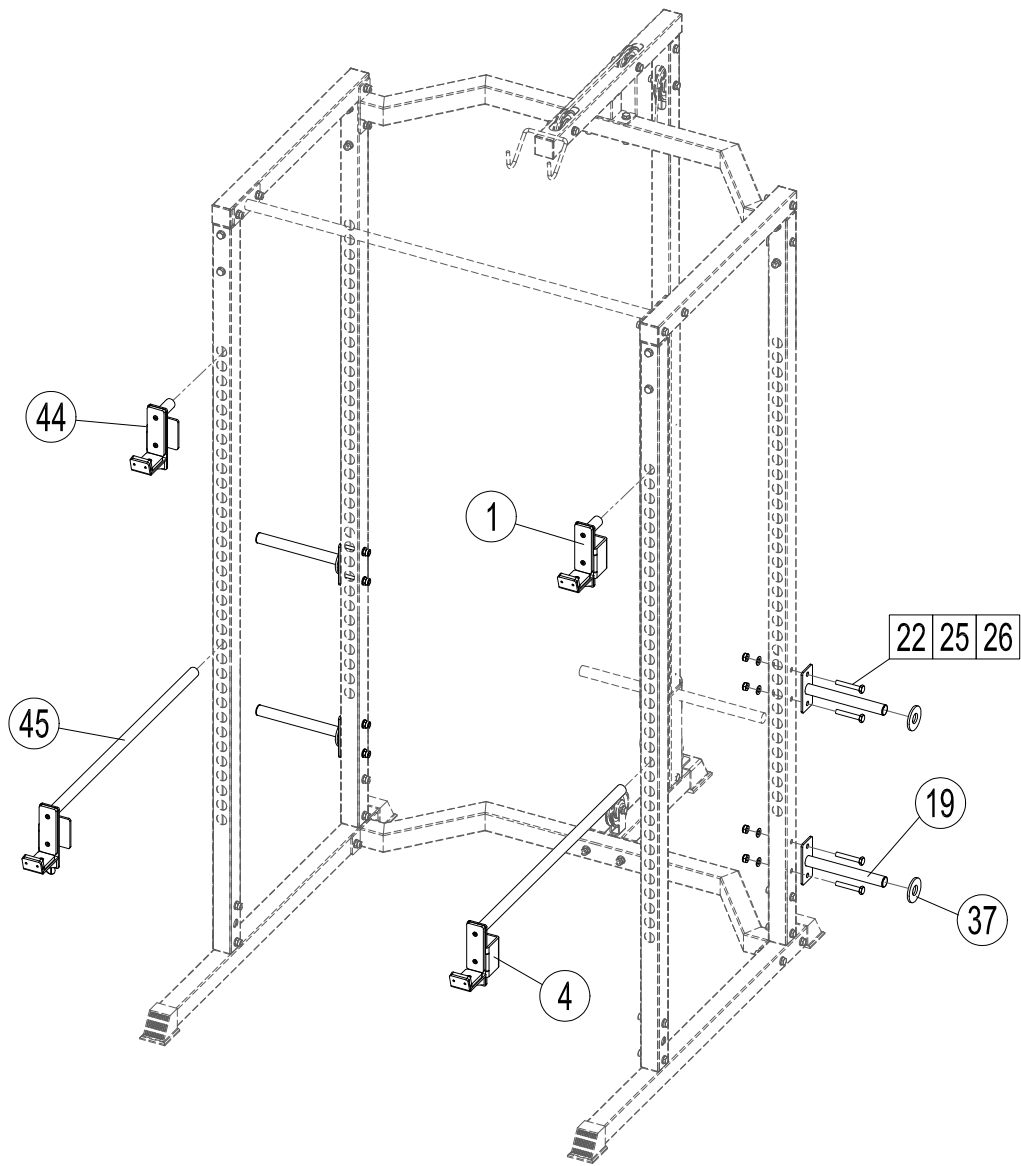

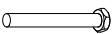

STEP 03



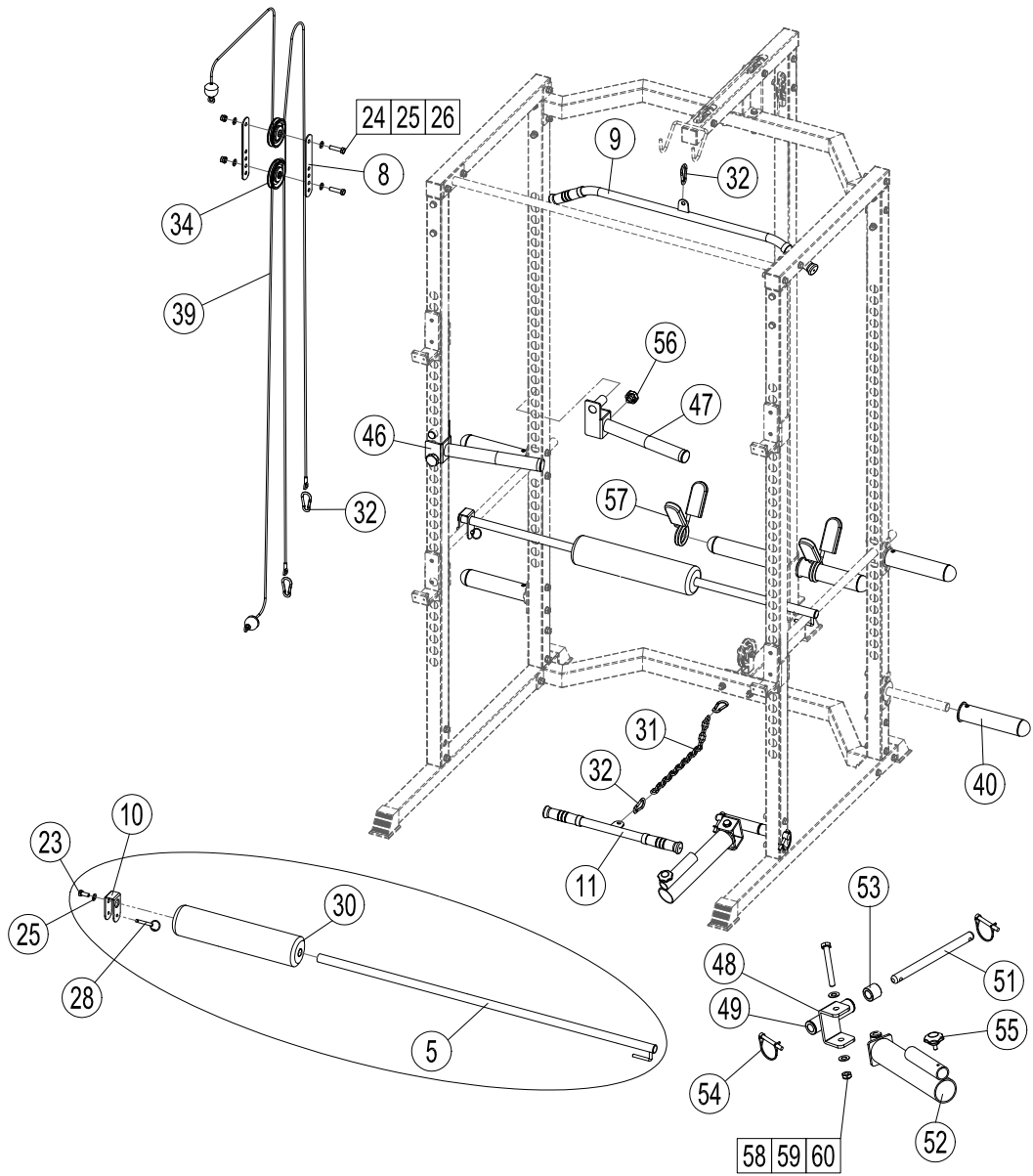

22#		M10*65	Qty:8
25#		10	Qty:8
26#		M10	Qty:8

STEP 04



23#		M10*20	Qty:1
24#		M10*40	Qty:2
25#		10	Qty:5
26#		M10	Qty:2

58#		M12*100	Qty:1
59#		12	Qty:2
60#		M12	Qty:1

STEP 05

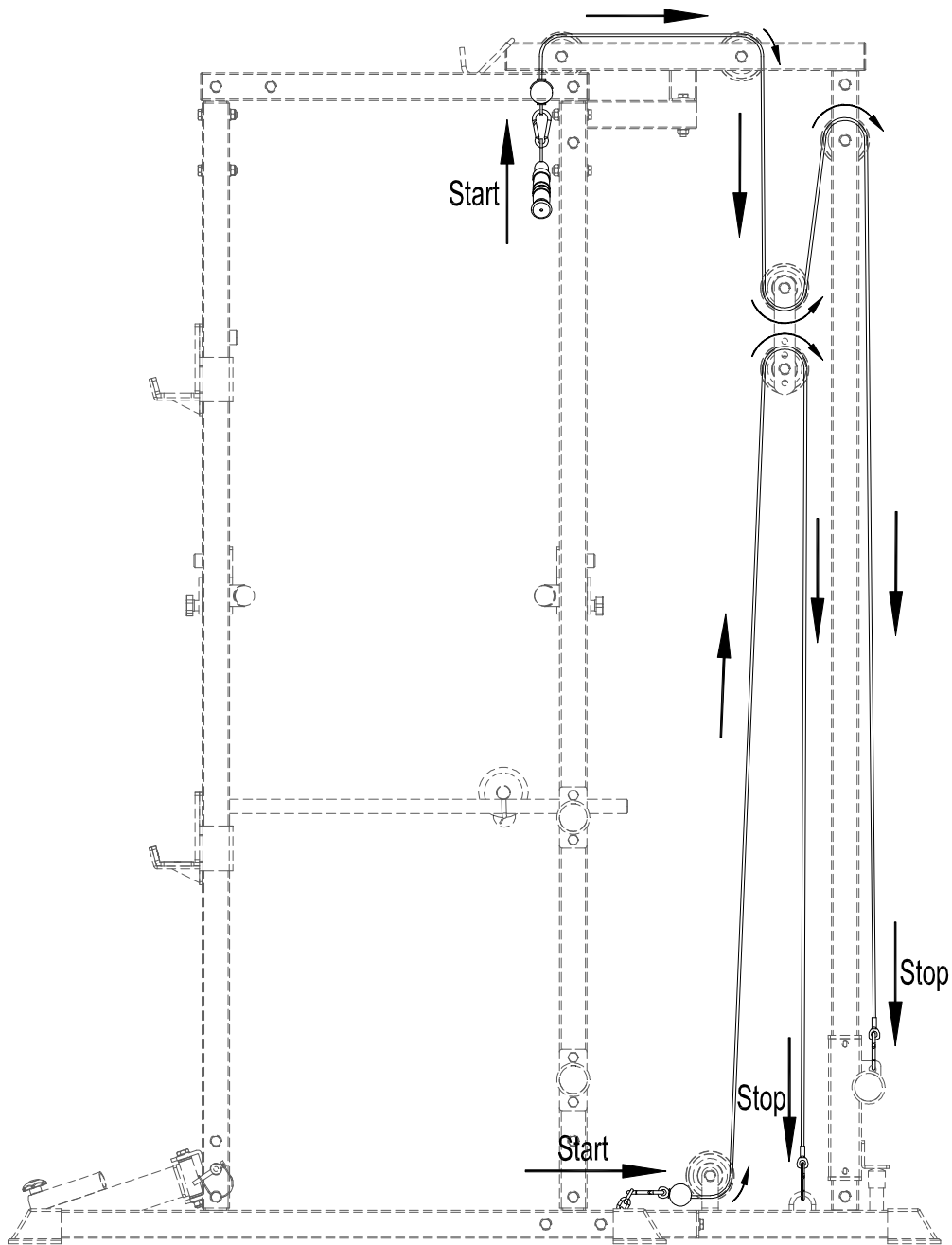

M10*65×26PCS

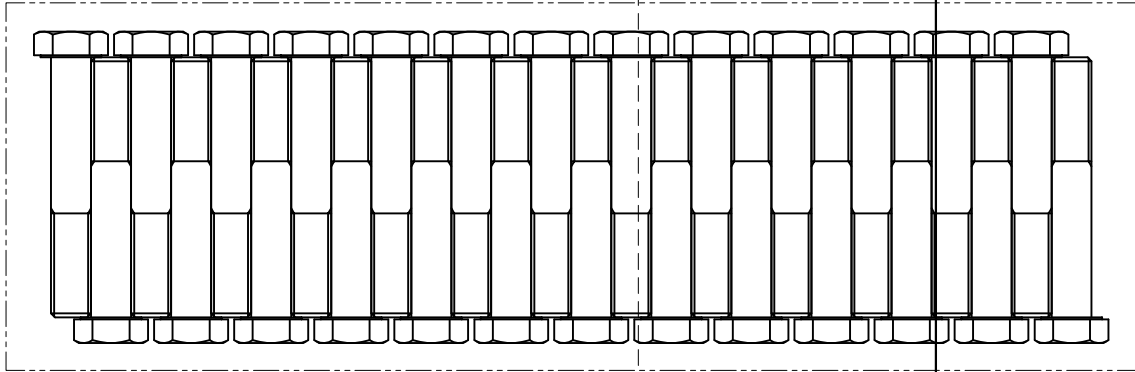

M10*70×19PCS

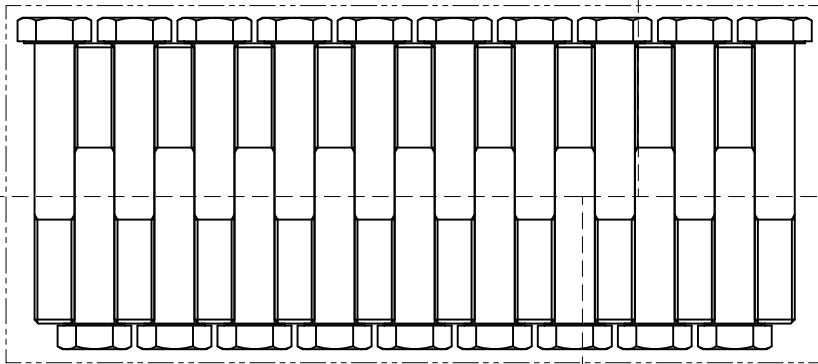

Ø10×89PCS

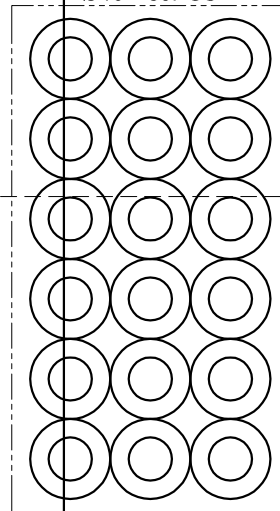

8x35 Locking Bolt : 1PC

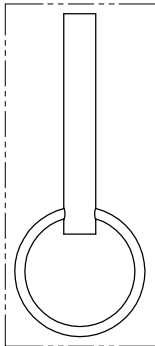

16 Pulley Sleeve: 6PCS

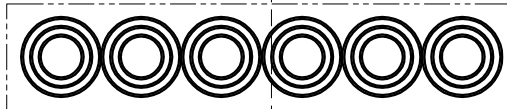

M10*40×3PCS

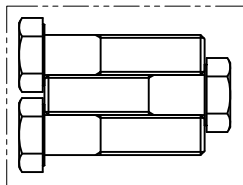

M10*20×1PC

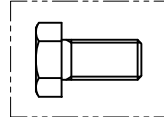

Ø12×2PCS

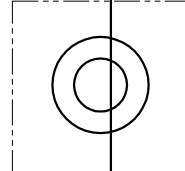

M12×1PC





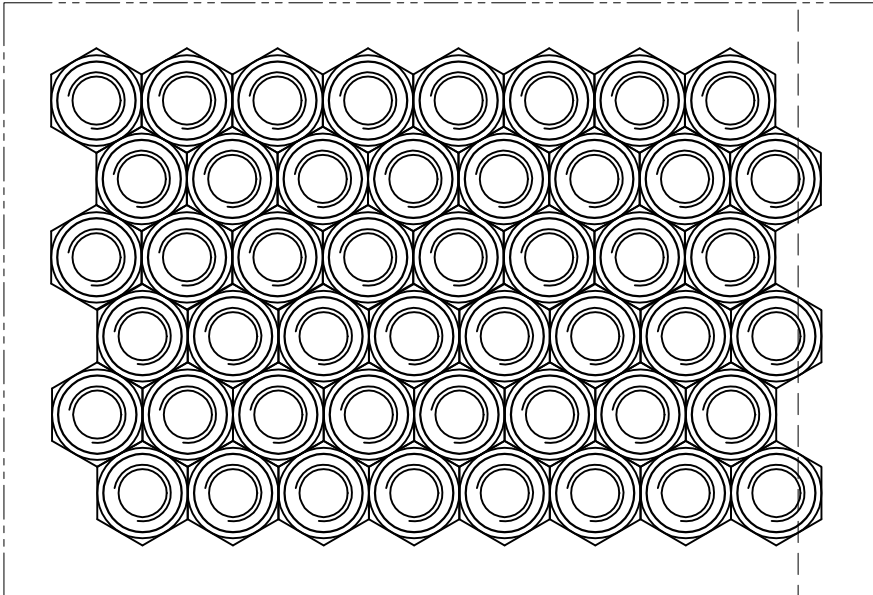



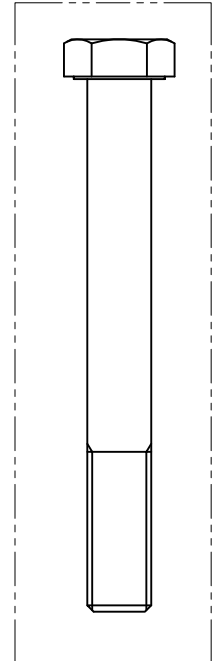



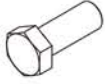
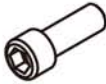

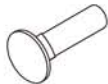

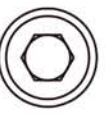
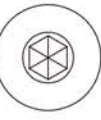

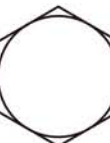
M10×48PCS











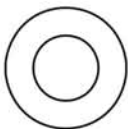
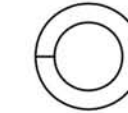

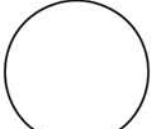

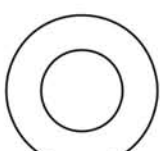
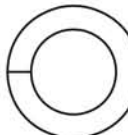
M12*100×1PC

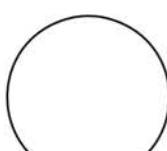
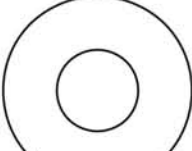
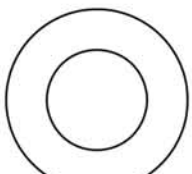
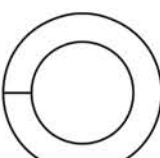

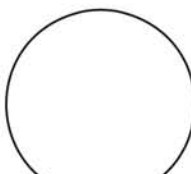
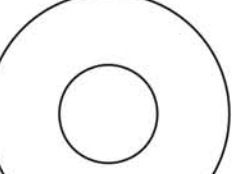
SIZE CHART

					
M8					
M10					
M12					

M8					
M10					
M12					
	Washer 	Spring Washer 	Lock Nut 	Nut Cap 	Big Washer 