

NOTE:  
Please read all  
instructions carefully  
before using this product

Table of Contents

Safety Notice

Important Assembly  
Information

Care and Maintenance

Parts List

Warranty

Ordering Parts

Model  
SM4008

Retain This  
Manual for  
Reference

201207

**OWNER'S  
MANUAL**



**MARCY®**

**MARCY®  
SMITH MACHINE  
SM-4008**

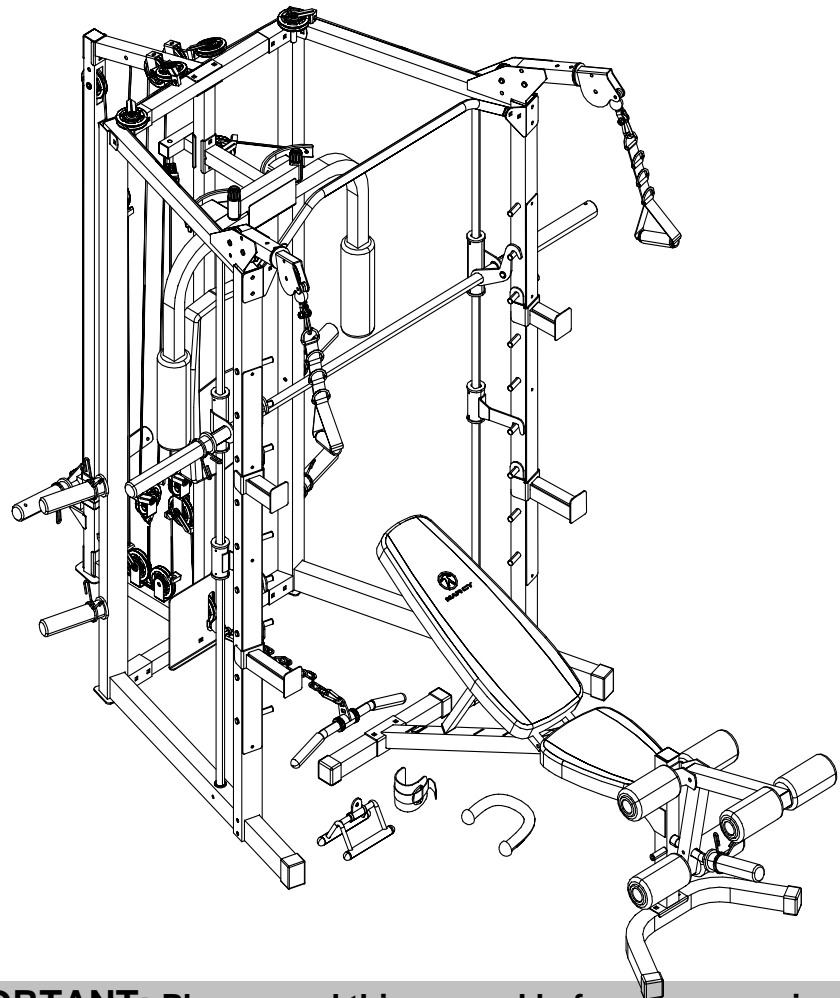

**IMPORTANT:** Please read this manual before commencing  
assembly of this product.

---

## TABLE OF CONTENTS

|                                      |    |
|--------------------------------------|----|
| BEFORE YOU BEGIN .....               | 1  |
| IMPORTANT SAFETY NOTICES.....        | 2  |
| EXERCISE GUIDELINE .....             | 3  |
| WARNING LABEL PLACEMENT .....        | 5  |
| FREE AND TRAINING AREA .....         | 6  |
| IMPORTANT ASSEMBLY INFORMATION ..... | 7  |
| CABLE ASSEMBLY INSTRUCTION .....     | 10 |
| WEIGHT CAPACITY AND DIMENSION .....  | 26 |
| CARE AND MAINTENANCE.....            | 26 |
| OPERATING NOTES.....                 | 26 |
| WEIGHT RESISTANCE CHART.....         | 27 |
| SMITH MACHINE PARTS LIST .....       | 28 |
| SMITH MACHINE EXPLODED DIAGRAM.....  | 31 |
| BENCH PARTS LIST .....               | 32 |
| BENCH EXPLODED DIAGRAM.....          | 33 |
| WARRANTY .....                       | 34 |
| ORDERING PARTS .....                 | 34 |

---

## BEFORE YOU BEGIN

Thank you for selecting the SM4008 Smith Machine Home Gym. For your safety and benefit, read this manual carefully before using the equipment. If you have any questions, or find there are missing or damaged parts, please contact our Customer Solutions Department.

**Pure-Tec Limited**  
**[www.puretecfitness.com](http://www.puretecfitness.com)**

**Email: [service@puretecfitness.com](mailto:service@puretecfitness.com)**

## IMPORTANT SAFETY NOTICE

This exercise equipment is built for optimum safety. However, certain precautions apply whenever you operate a piece of exercise equipment. Be sure to read the entire manual before you assemble or operate your equipment. Note the following safety precautions:

- 1. Keep children and pets away from the equipment at all times. DO NOT leave children unattended in the same room with the equipment.**
2. Only one person at a time should use the equipment.
3. If the user experiences dizziness, nausea, chest pain, or any other abnormal symptoms, STOP the workout at once. CONSULT A PHYSICIAN IMMEDIATELY.
4. Position the equipment on a clear, levelled surface. DO NOT use the equipment near water or outdoors.
5. Keep hands away from all moving parts.
6. Always wear appropriate workout clothing when exercising. DO NOT wear robes or other clothing that could become caught in the equipment. Running or aerobic shoes are also required when using the equipment.
7. Use the equipment only for its intended use as described in this manual. DO NOT use attachments not recommended by the manufacturer.
8. Do not place any sharp object around the equipment.
9. Disabled persons should not use the equipment.
10. Before using the equipment to exercise, always do stretching exercises to properly warm up.
11. Never operate the equipment if the equipment is not functioning properly.
12. A spotter is recommended during exercise.
- 13. This equipment is designed and intended for home and consumer use only, not for commercial use.**

**WARNING: BEFORE BEGINNING ANY EXERCISE PROGRAM, CONSULT YOUR PHYSICIAN. THIS IS ESPECIALLY IMPORTANT FOR INDIVIDUALS OVER THE AGE OF 35 OR PERSONS WITH PRE-EXISTING HEALTH PROBLEMS. READ ALL INSTRUCTIONS BEFORE USING ANY FITNESS EQUIPMENT. PURETEC LTD ASSUMES NO RESPONSIBILITY FOR PERSONAL INJURY OR PROPERTY DAMAGE SUSTAINED BY OR THROUGH THE USE OF THIS PRODUCT.**

**SAVE THESE INSTRUCTIONS.**

## **EXERCISE GUIDELINES**

### ***Building Muscle and Gaining Weight***

Unlike aerobic exercise, which emphasizes endurance training, anaerobic exercise focuses on strength training. A gradual weight gain can occur while building the size and strength of muscles. While developing muscle mass, your body adapts to the stress placed upon it. You can modify your diet to include foods such as meat, fish and vegetables. These foods help muscles recover and replenish important nutrients after a strenuous workout.

### ***Muscle Strength and Endurance***

To achieve the greatest benefit from exercise, it is important to develop an exercise program that allows you to work all of the major muscle groups equally.

To increase muscle strength, follow this principle:

Increasing resistance and maintaining the number of repetitions of an exercise results in increased muscle strength.

To tone your body, follow this principle: Decreasing resistance plus increasing the number of repetitions of an exercise results in increased body tone.

Once you feel comfortable with an exercise, you can change the resistance, the number of repetitions, or the speed at which you do the exercise. It is not necessary to change all three variables. For example, let's say that you are training at 23 kg and performing the exercise 10 times in 3 minutes. When this becomes too easy, you may decide to move up to lifting 27 kg for the same number of repetitions in the same amount of time. Lifting more weights fewer times most often develops muscle strength. To gain both muscle strength and endurance, it is recommended that you perform each exercise 15 to 20 reps per set.

### ***Training Intensity***

How hard you begin to train depends on your overall level of fitness. The soreness you experienced can be lessened by decreasing the load you place on your muscles and by performing fewer sets. To avoid injury, you should gradually work into an exercise program and set the load to your individual fitness level. The load should increase as your fitness level increases.

Muscle soreness is common, especially when you first start exercising. If you are painfully sore for a long time, it may be time to change your program. Eventually, your muscle system will become accustomed to the stress and strain placed on it.

## ***Beginning a Strength Building Program***

### ***Warming Up***

To begin strength training, it is important to stretch and perform light exercise for 5 to 10 minutes. This helps prepare the body for more strenuous exercise by increasing circulation, raising your body temperature and developing more oxygen to your muscles.

### ***Workout***

For each workout, to keep in mind that muscle soreness that lasts for a long period is not desirable and may mean that injury has occurred.

### ***Cool Down***

At the end of each workout, perform slow stretching exercises for 5 to 10 minutes. Ease into each stretch only going as far as you can. This stage allows your muscles to wind down after training.

To provide a total workout program it is also recommended that 2 to 3 days of aerobic exercise is performed in addition to the strength training.

### ***Drinking Water***

For the body to function properly, it must be properly hydrated. If you are exercising, you should increase your fluid intake. The reason for this is that the water you take in will leave your system through the sweating mechanism that cools your body during exercise. The water you lose through exercise must be replaced so that the muscles can recover properly.

### ***Rest Day***

Although you may not feel like doing it, taking a rest day at least once a week is important because it gives your body a chance to heal itself. Continuously working your muscles will result in over-training, which will not benefit you in the long run.

## WARNING LABEL PLACEMENT

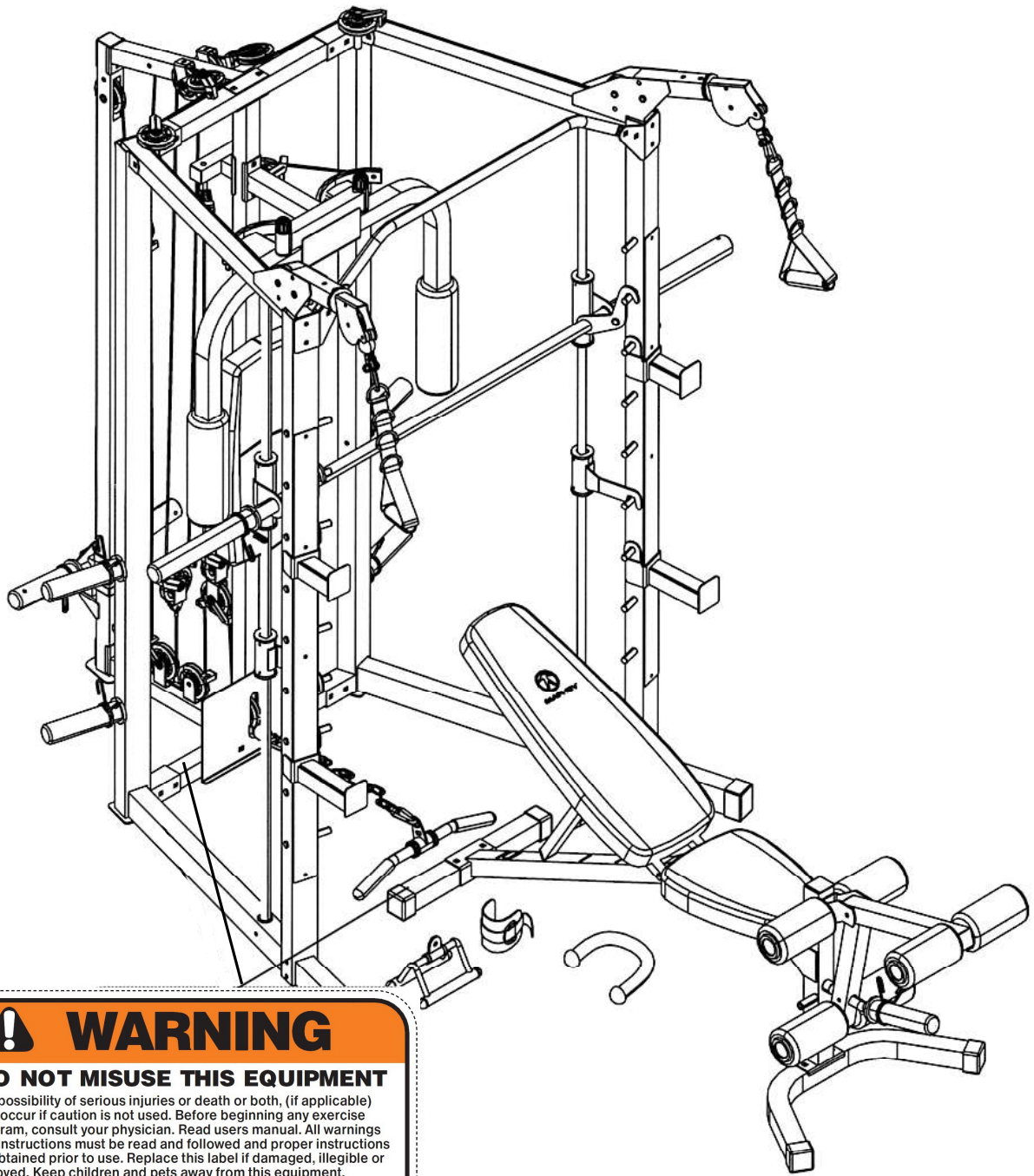

The warning labels shown here have been placed on the right support base frame. If the labels are missing or illegible, please contact Customer Solutions by email: [service@puretecfitness.com](mailto:service@puretecfitness.com) for replacements. Apply the labels in the location shown.

# FREE AND TRAINING AREA

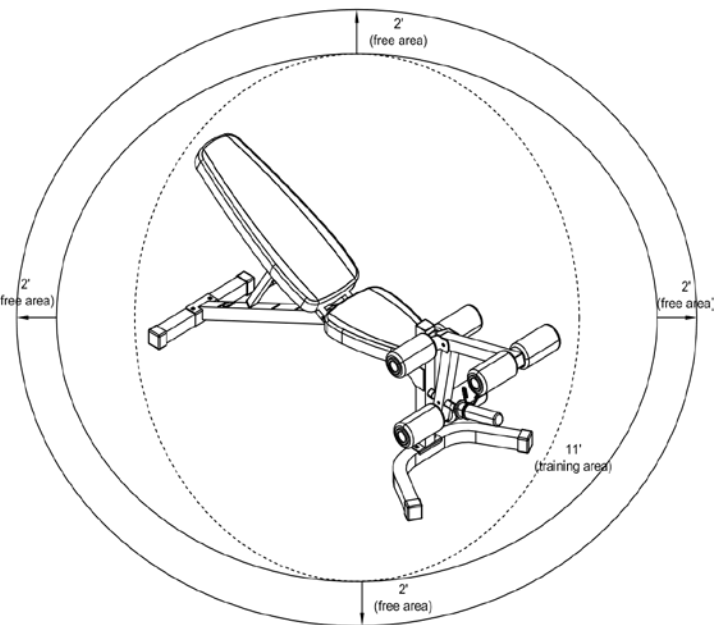
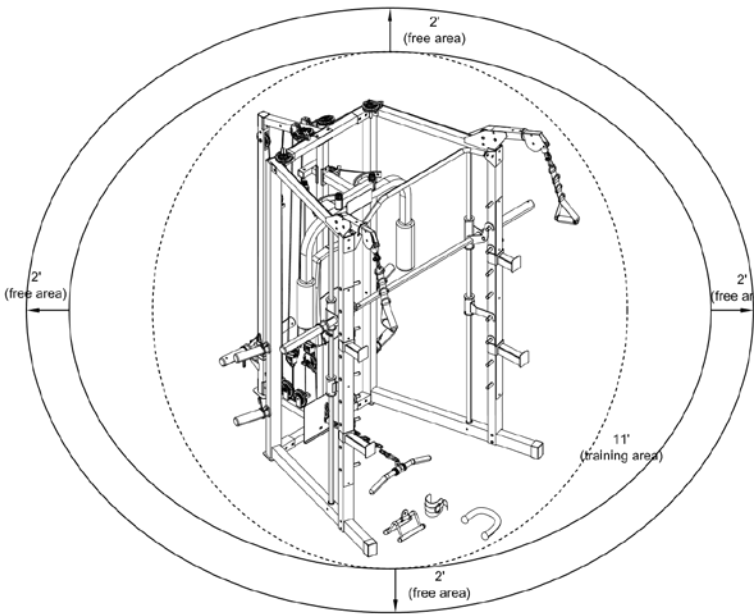
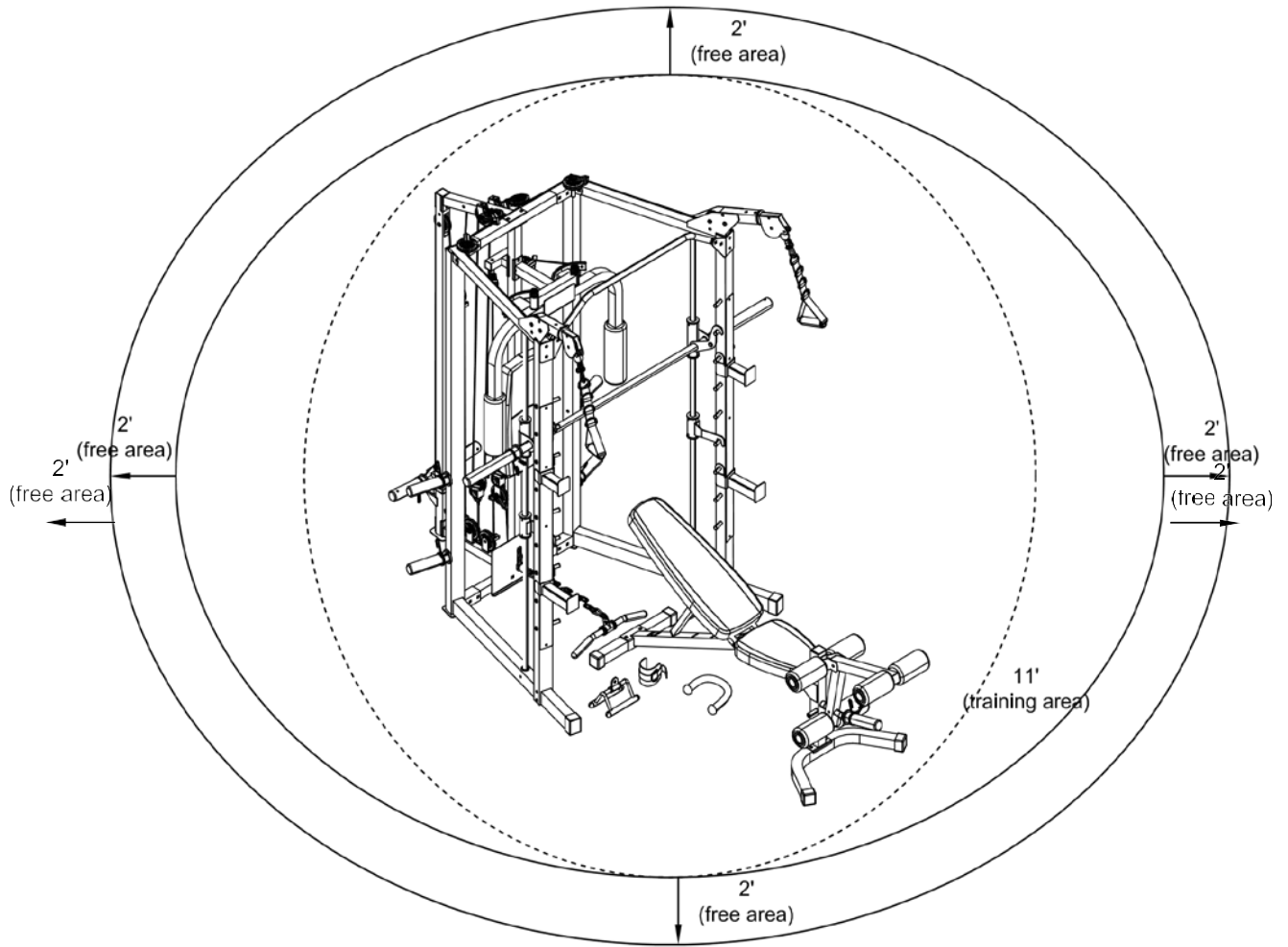

## IMPORTANT ASSEMBLY INFORMATION

- ❖ Tools required for assembling the bench: Two adjustable Wrenches and Allen wrenches.
- ❖ NOTE: It is strongly recommended that this equipment be assembled by two or more people to avoid possible injury.
- ❖ Ensure **Carriage Bolts** are inserted through the **SQUARE holes** on components that need to be assembled. Attach washer only to end of the Carriage Bolt.
- ❖ Use **Allen Bolts or Hex Bolts** inserted through the **ROUND hole** on components that need to be assembled.
- ❖ Always wait until all bolts are assembled onto the bench before tightening the bolts. Do not tighten each bolt right after it is installed

### Fasten Nuts and Bolts

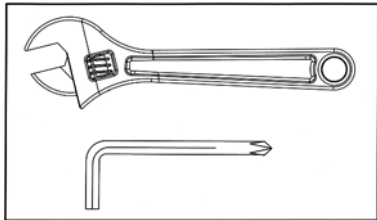

**Securely tighten all nuts and bolts after all components have been assembled in current and previous steps.**  
**NOTE: Do not over-tighten any component with pivoting function.**  
**Make sure all pivoting components are able to move freely.**

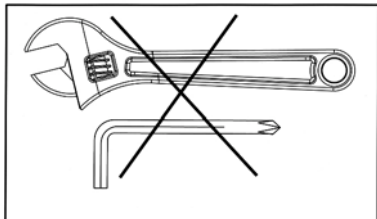

**Do not tighten all nuts and bolts in this step.**

- ❖ **Inspect and ensure all bolts and Nuts are fastened after the equipment is completely assembled.**

### Assemble with correct Hardware Pack

- ❖ Only use the hardware packs marked "For Smith Machine" to assemble Smith Machine.
- ❖ Only use the hardware packs marked "For Bench" to assemble Bench.

### Tools

Tools required for assembling this equipment: Allen Wrenches (provided by manufacturer), and Adjustable Wrench, or Socket Wrench, or Ratchet Wrench.

**NOTE: It is strongly recommended that this machine be assembled and moved by two or more people to avoid possible injury.**



**Please ensure that the incline support arm is properly and fully seated and engaged with the frame slot before engaging in any exercise.**

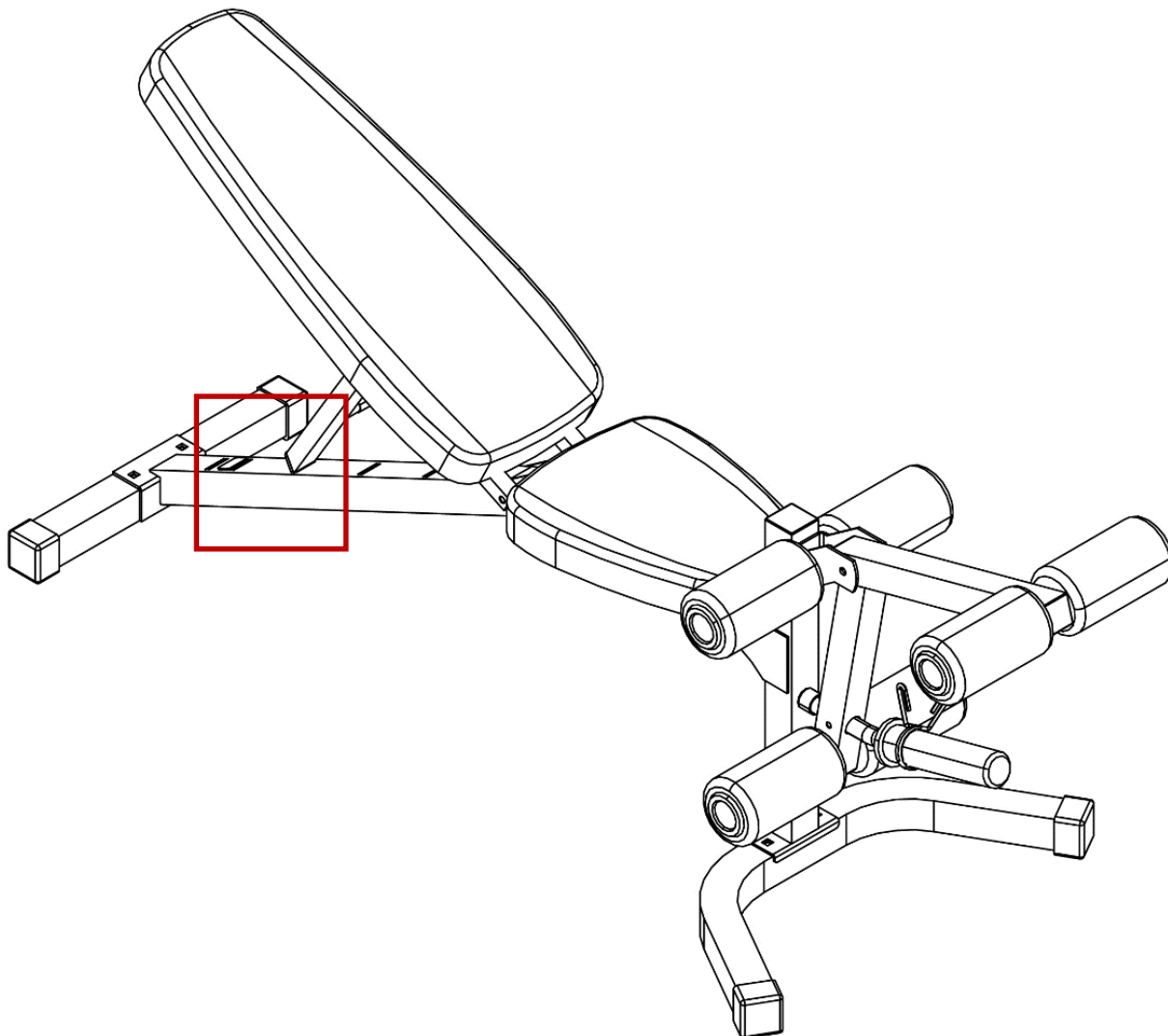
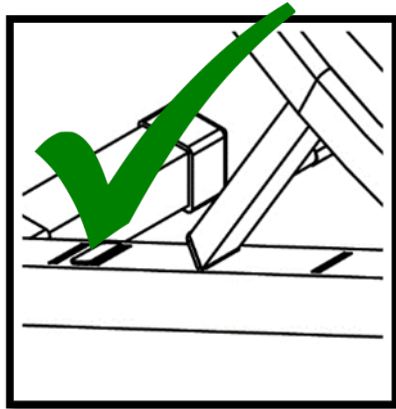

## Assemble Sliding Weight Post in assembly Step-6

The **triangular bracket** on the Sliding Weight Post (Part #23) must be facing up and toward to back.

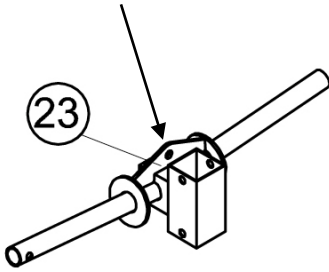

## Weight Bar Assembly Note

NOTE: Help of another person is strongly recommended for this step. Place the Lifting Sleeve (#28) in between the two Safety Stop Frames (#25). Align the holes. Insert the Weight Bar (#29) into the Safety Stop Frame from one end and through the Lifting Sleeve (#28) to the other Safety Stop Frame on the opposite side. Secure the Weight Bar to each Safety Stop Frame with two pre-installed M8 x 3/8" Allen Bolts (#104) on each Safety Stop Frame. Ensure the Bolts are fastened so the Weight Bar won't slide through the Safety Stop Frame.

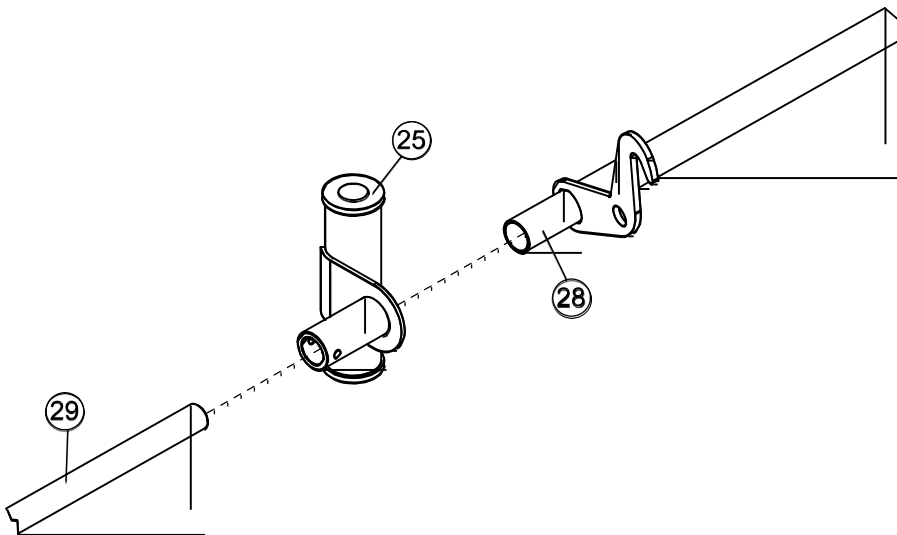

# SMITH MACHINE CABLE ASSEMBLY INSTRUCTION

## Cable Loop Diagram

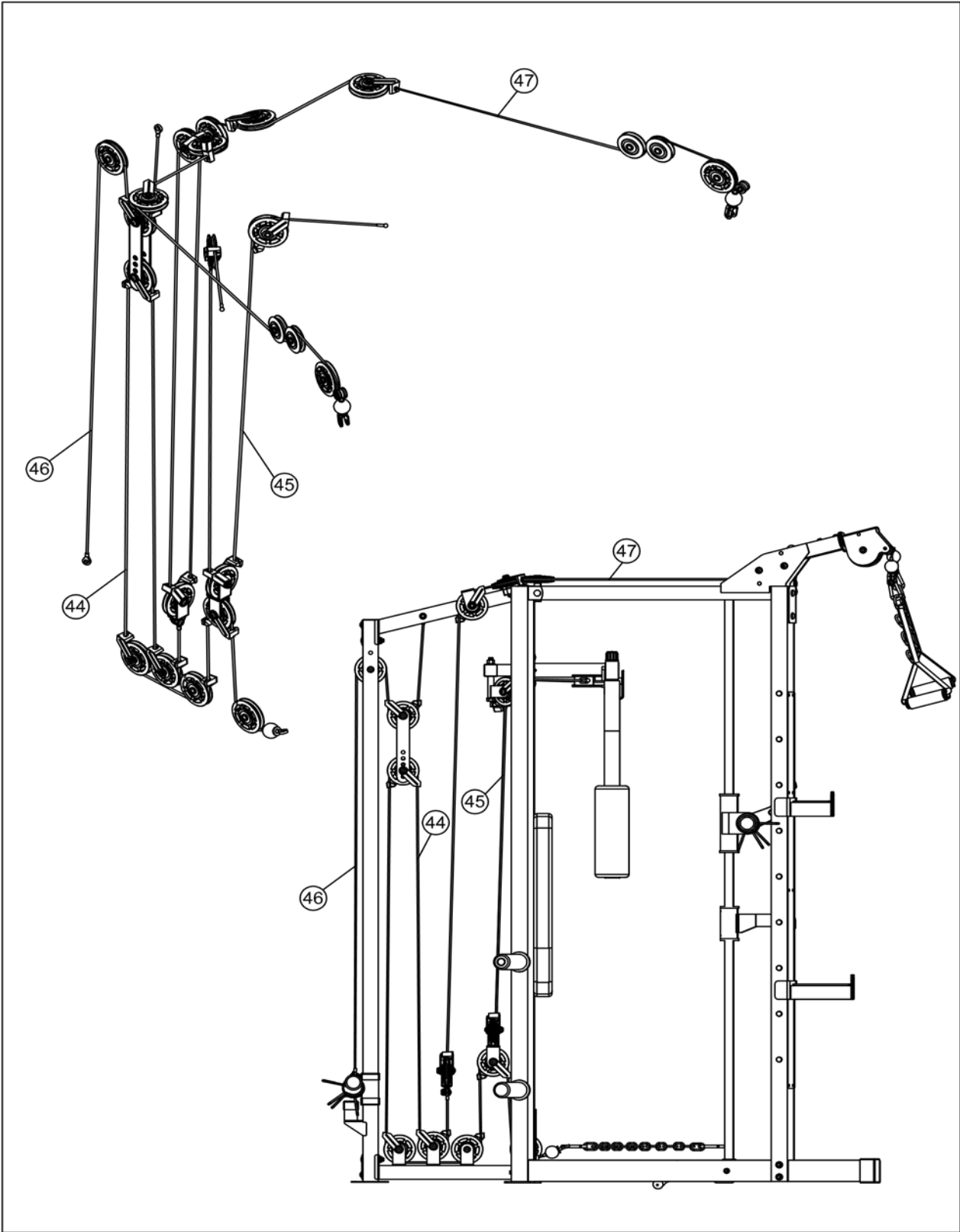

## **Butterfly Cable assembly instruction Step-11**

- A.) Attach one end of 113" Butterfly Cable (#45) to the clip on Right Butterfly (#13). Draw the Cable to the right Swivel Pulley Bracket (#15).
- B.) Attach a Pulley (#62) and two Cable Retainers (#78) to the Bracket. Secure them with one M10 x 2" Allen Bolt (#94), two  $\text{\O} \frac{3}{4}$ " Washers (#107), and one M10 Aircraft Nut (#110).
- C.) Draw the Cable around the Pulley then downward. Attach an Angled Floating Pulley Bracket (#52) to the Cable. Repeat Procedure B above to install a Pulley. Let the Bracket hanging for now.
- D.) Draw the Cable around the Pulley then upward to the left Swivel Pulley Bracket. Repeat Procedure B above to install a Pulley to the Bracket.
- E.) Draw the Cable around the Pulley then clip to the Left Butterfly (#12).

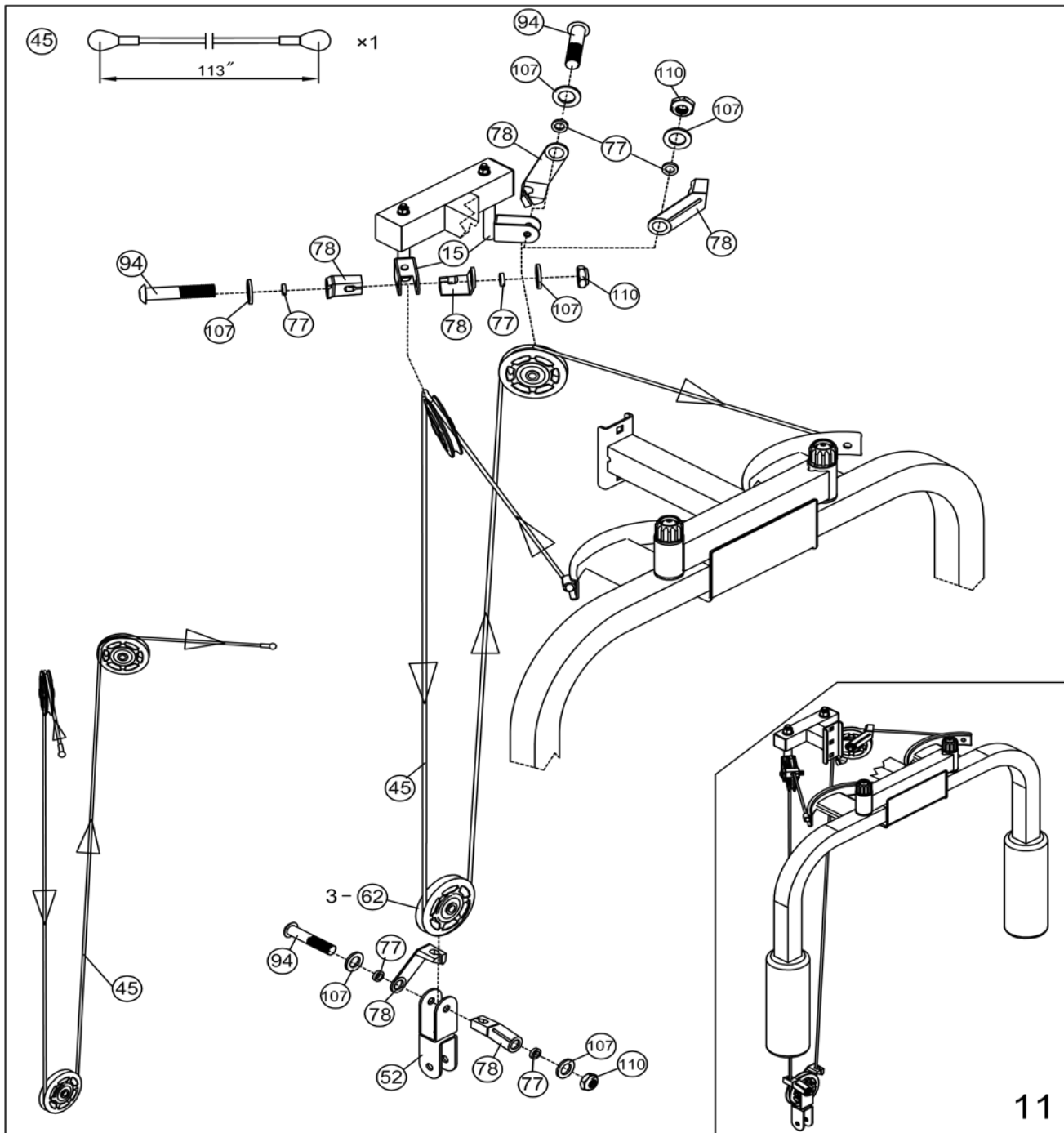

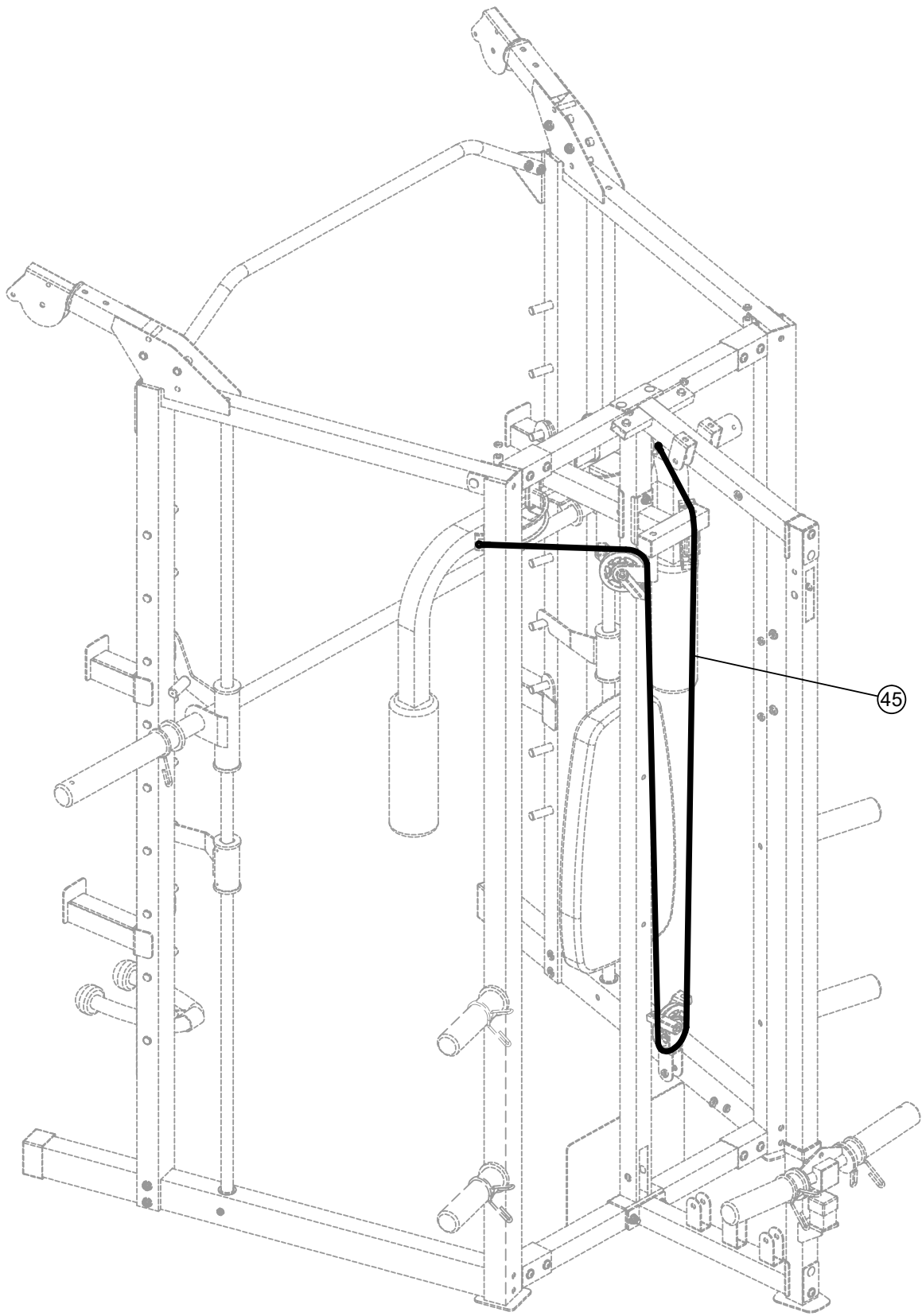

11-A

## **Upper Cable assembly instruction Step-12**

- A.) Attach one Cross-over Swivel Pulley Bracket (#10) to right Upper Side Frame (#7). Secure it with four M8 x  $\frac{3}{8}$ " Allen Bolts (#101) and four  $\varnothing \frac{5}{8}$ " Washers (#106).
- B.) Attach a Pulley (#62) to the right Swivel Bracket and secure it with one M10 x 1  $\frac{3}{4}$ " Allen Bolt (#93), two  $\varnothing \frac{3}{4}$ " Washers (#107), and one M10 Aircraft Nut (#110).
- C.) Remove the U-shaped Connector, Big Washer, and Ball Stopper from one end of the 261" Upper Cable (#47).
- D.) Insert the open end of Upper Cable through the right Swivel Bracket. Draw the Cable over the Pulley and pull it toward the back of the machine.
- E.) Attach a Cable Roller (#42) to the right Swivel Bracket. Secure it with one M8 x 1  $\frac{5}{8}$ " Allen Bolt (#102), two  $\varnothing \frac{5}{8}$ " Washers (#106), and one M8 Aircraft Nut (#109).
- F.) Attach a Small Pulley (#63) to the opening on the right Upper Side Frame (#7). Secure it with one M10 x 2  $\frac{3}{4}$ " Allen Bolt (#97), two  $\varnothing \frac{3}{4}$ " Washers (#107), and one M10 Aircraft Nut (#110). Draw the Cable around the top of the Small Pulley.
- G.) Attach another Small Pulley to the opening next to the Small Pulley installed in Procedure F. Secure it with one M10 x 2  $\frac{3}{4}$ " Allen Bolt (#97), two  $\varnothing \frac{3}{4}$ " Washers (#107), and one M10 Aircraft Nut (#110). Draw the Cable under the Small Pulley to an open pulley shaft.
- H.) Connect a Single Handle (#79) to the Cable End under the right Swivel Pulley Bracket with a Hook (#73). Secure the Hook to the U-shaped Connector with one M10 x 1  $\frac{1}{8}$ " Allen Bolt (#92) and one M10 Aircraft Nut (#110).

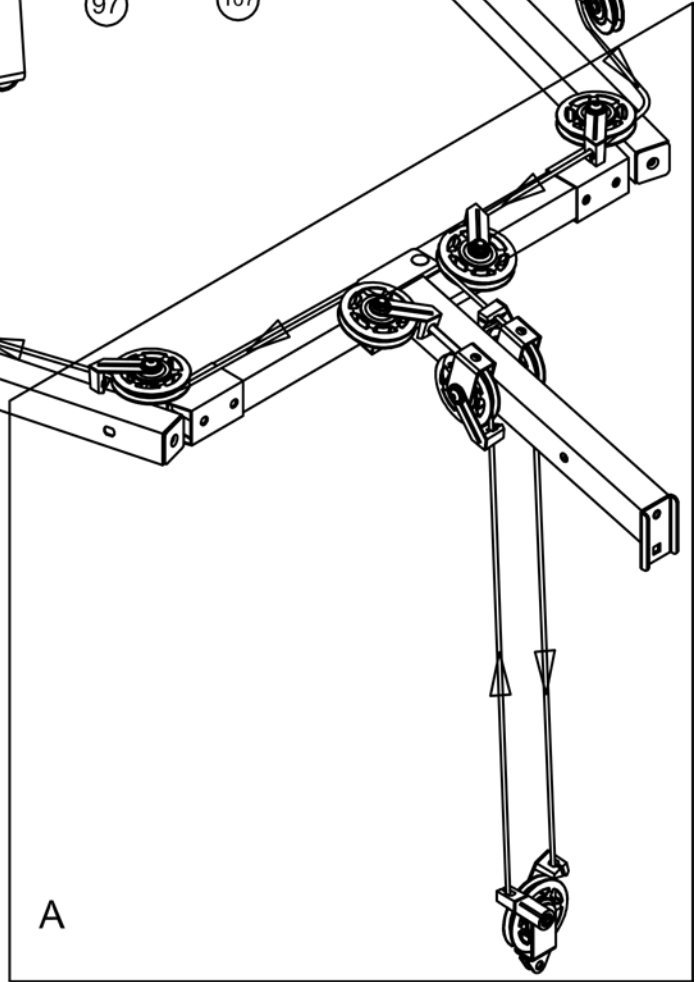
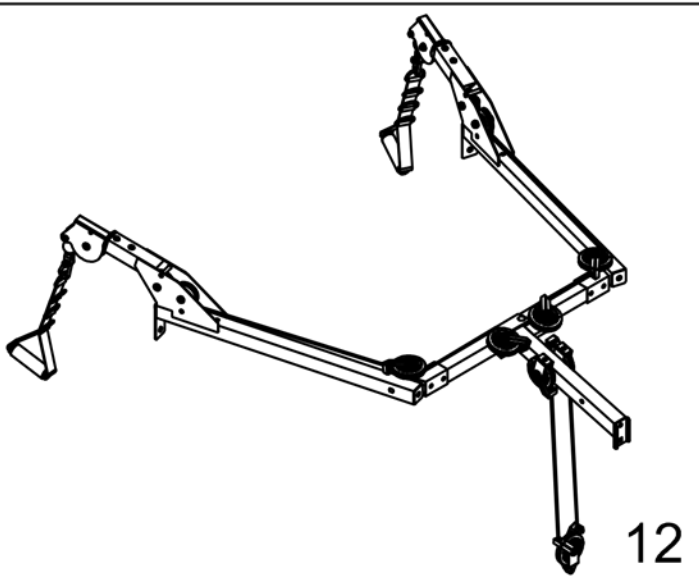
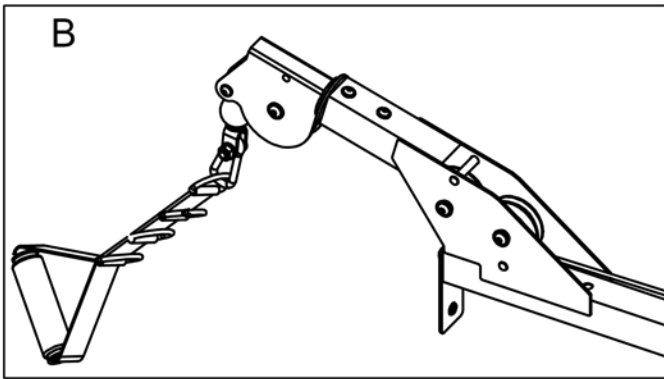
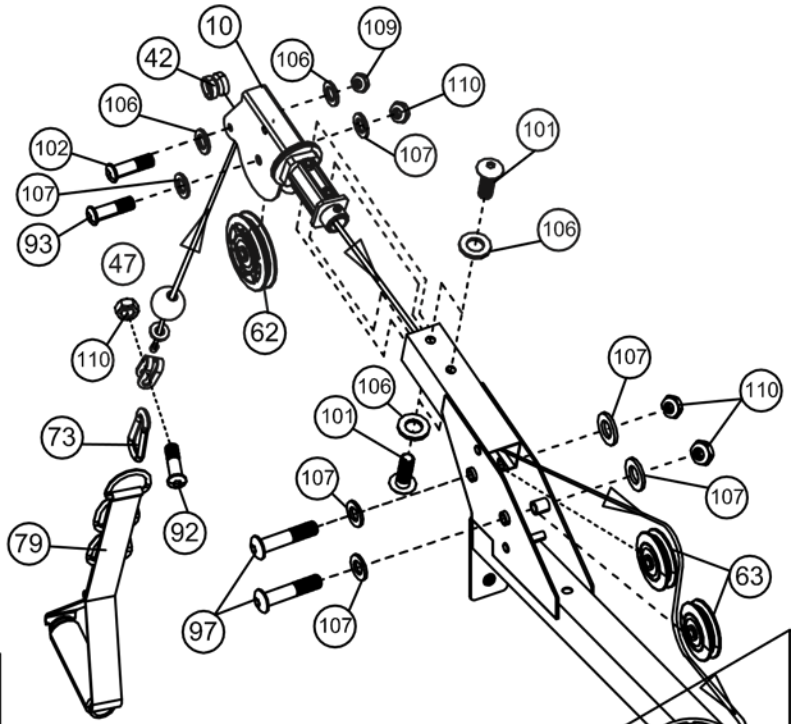
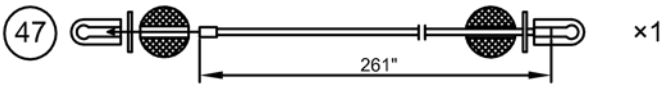

## **Upper Cable assembly instruction Step-12 A**

- A. Attach a Pulley (#62) to the open pulley shaft. Secure it with one M10 x 1  $\frac{3}{4}$ " Allen Bolt (#93), one  $\varnothing \frac{3}{4}$ " Washer (#107), and one Cable Retainer (#78).
- B. Draw the Cable around the Pulley then to the next open pulley shaft on Rear Upper Frame (#18). Attach a Pulley to the open shaft. Secure it with one M10 x 2  $\frac{3}{4}$ " Allen Bolt (#97), two  $\varnothing \frac{3}{4}$ " washers (#107), one Cable Retainer (#78), and one M10 Aircraft Nut (#110).
- C. Draw the Cable around the Pulley and to the open bracket on right side of the Rear Upper Frame (#18). Attach a Pulley (#62) to the bracket. Secure it with one M10 x 5" Allen Bolt (#99), one Cable Retainer (#78), two  $\varnothing \frac{3}{4}$ " Washers (#107), and one M10 Aircraft Nut (#110).
- D. Draw the Cable around the Pulley and then downward. Attach a Pulley to a Single Floating Pulley Bracket (#34). Secure the Pulley with one M10 x 2" Allen Bolt (#94), two  $\varnothing \frac{3}{4}$ " Washers (#107), two Cable Retainers (#78), and one M10 Aircraft Nut (#110). Draw the Cable around the Pulley and upward to the open bracket on the left side of the Rear Upper Frame. Let the Pulley hanging for now.
- E. Remove the M10 x 5" Allen Bolt (#99), Nut, and Washers installed in Procedure C. Attach a Pulley to the other open bracket on the left side of the Rear Upper Frame. Insert a washer onto the M10 x 5" Allen Bolt, then attach a Cable Retainer (#78) to the Pulley, and secure with the removed Washer and Nut.
- F. Draw the Cable to an open shaft on Rear Upper Frame. Attach a pulley. Secure it with M10 x 2  $\frac{3}{4}$ " Allen Bolt (#97), two  $\varnothing \frac{3}{4}$ " Washers (#107), one Cable Retainer (#78), and one M10 Aircraft Nut (#110).
- G. Draw the Cable to next open shaft. Attach a Pulley to the open shaft. Secure it with one M10 x 1  $\frac{3}{4}$ " Allen Bolt (#93), one  $\varnothing \frac{3}{4}$ " Washer (#107), and one Cable Retainer (#78).
- H. Draw the Cable to the opening on the left Upper Side Frame (#7).



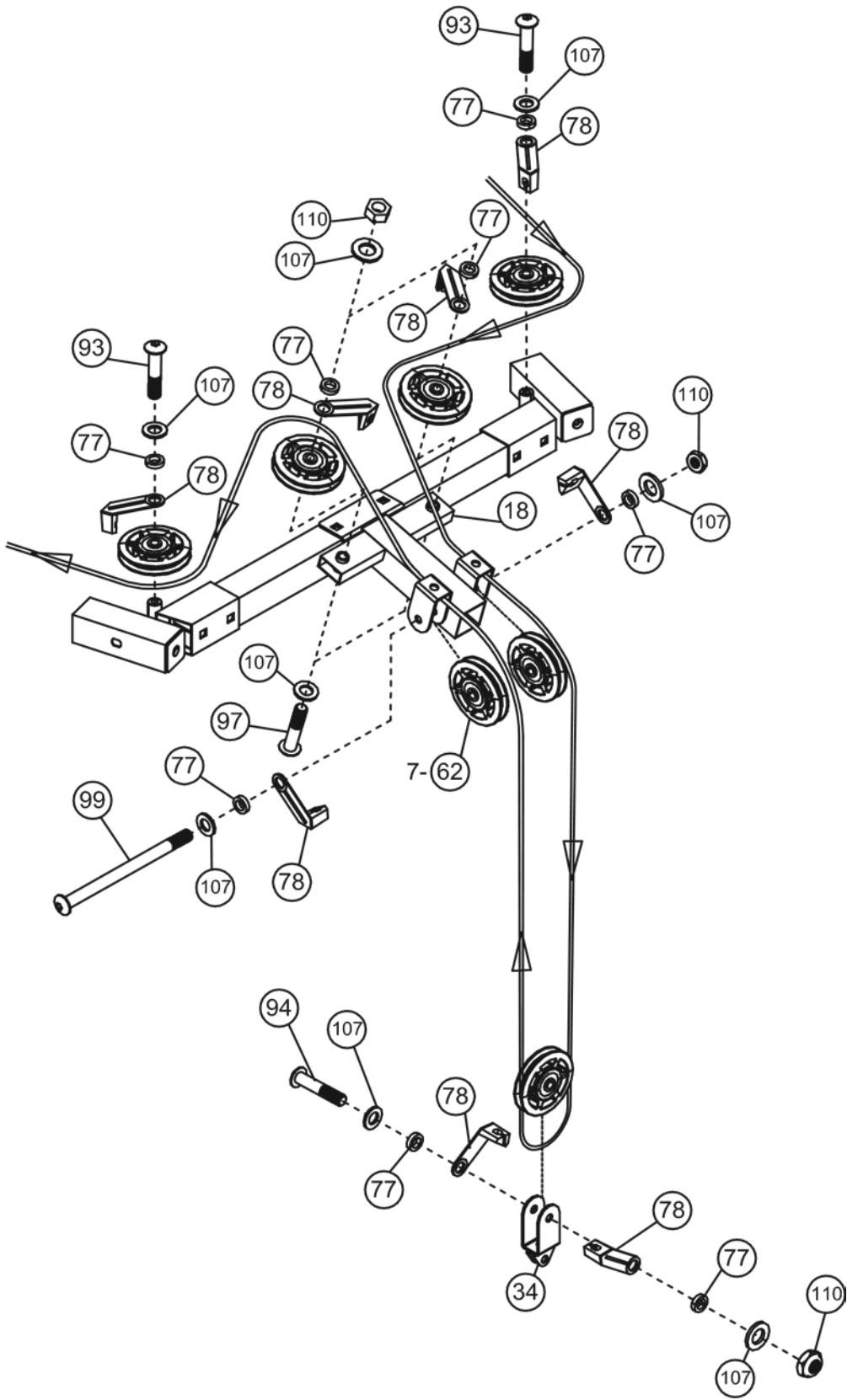

12-A

## **Upper Cable assembly instruction Step-12 B**

- A.) Attach a Small Pulley to the opening on left Upper Side Frame (#7). Secure the Small Pulley with one M10 x 2  $\frac{3}{4}$ " Allen Bolts (#97), two  $\varnothing \frac{3}{4}$ " Washers (#107), and one M10 Aircraft Nut (#110).
- B.) Draw the Cable under the Small Pulley and then pull up.
- C.) Attach a Small Pulley to the next opening. Secure it with one M10 x 2  $\frac{3}{4}$ " Allen Bolts (#97), two  $\varnothing \frac{3}{4}$ " Washers (#107), and one M10 Aircraft Nut (#110). Draw the Cable around the top of the Small Pulley.
- C.) Attach a Cross-over Swivel Pulley Bracket (#10) to the right Upper Side Frame (#7). Secure it with four M8 x  $\frac{3}{8}$ " Allen Bolts (#101) and four  $\varnothing \frac{5}{8}$ " Washers (#106).
- D.) Attach a Pulley to the Swivel Pulley. Secure it with one M10 x 1  $\frac{3}{4}$ " Allen Bolt (#93), two  $\varnothing \frac{3}{4}$ " Washers (#107), and one M10 Aircraft Nut (#110).
- F.) Draw the Cable around the top of the Pulley and through to the outside of Swivel Bracket. Attach a Cable Roller (#42) to the left Swivel Bracket. Secure it with one M8 x 1  $\frac{5}{8}$ " Allen Bolt (#102), two  $\varnothing \frac{5}{8}$ " Washers (#106), and one M8 Aircraft Nut (#109).
- G.) Re-install the Ball Stopper; Big Washer, and the U-shaped Connector to the end of the Cable.
- H.) Connect a Single Handle (#79) to the end of the Cable with a Hook (#73). Secure the Hook to the U-shaped Connector with one M10 x 1  $\frac{1}{8}$ " Allen Bolt (#92) and M10 Aircraft Nut (#110).

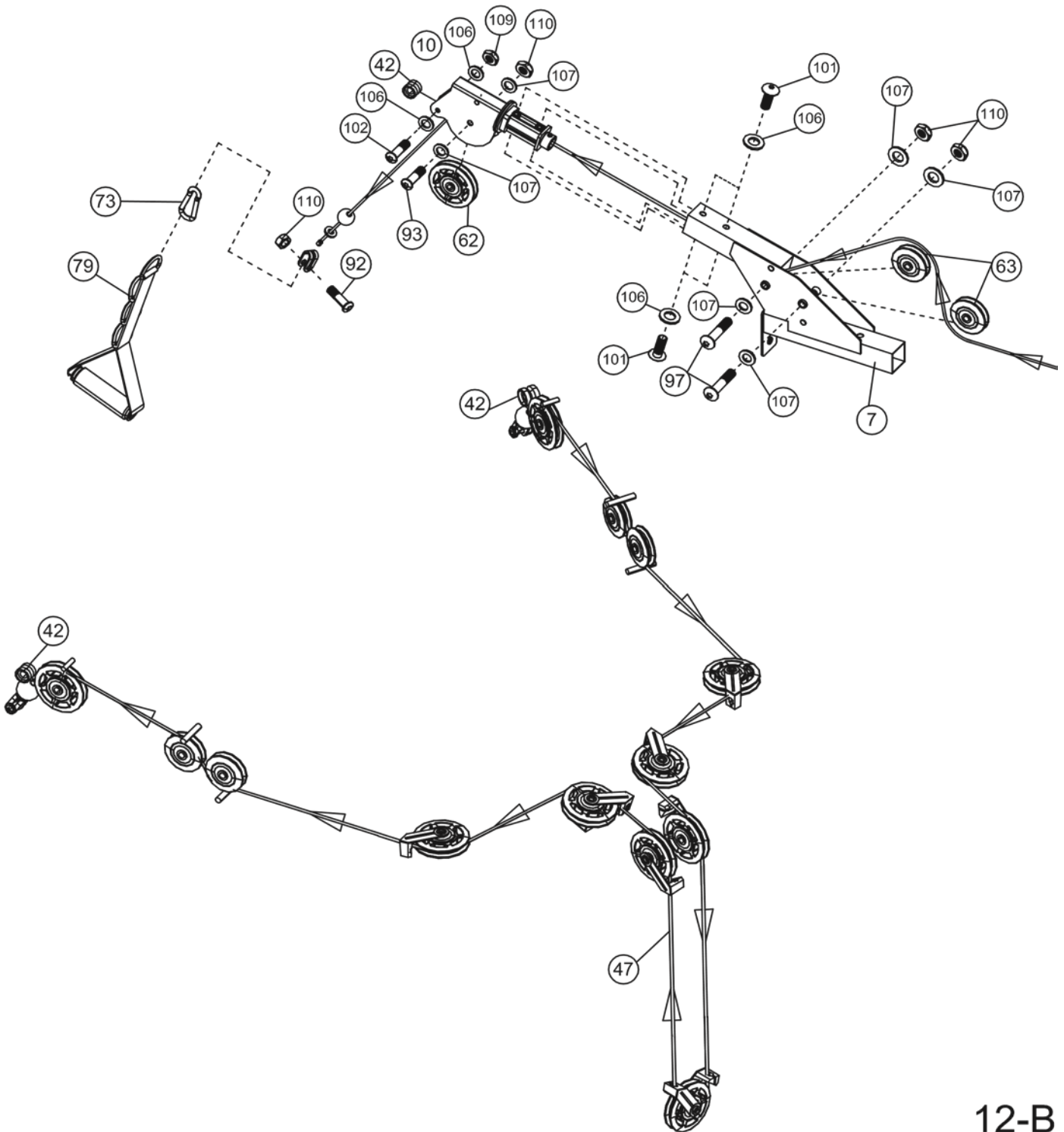

12-B

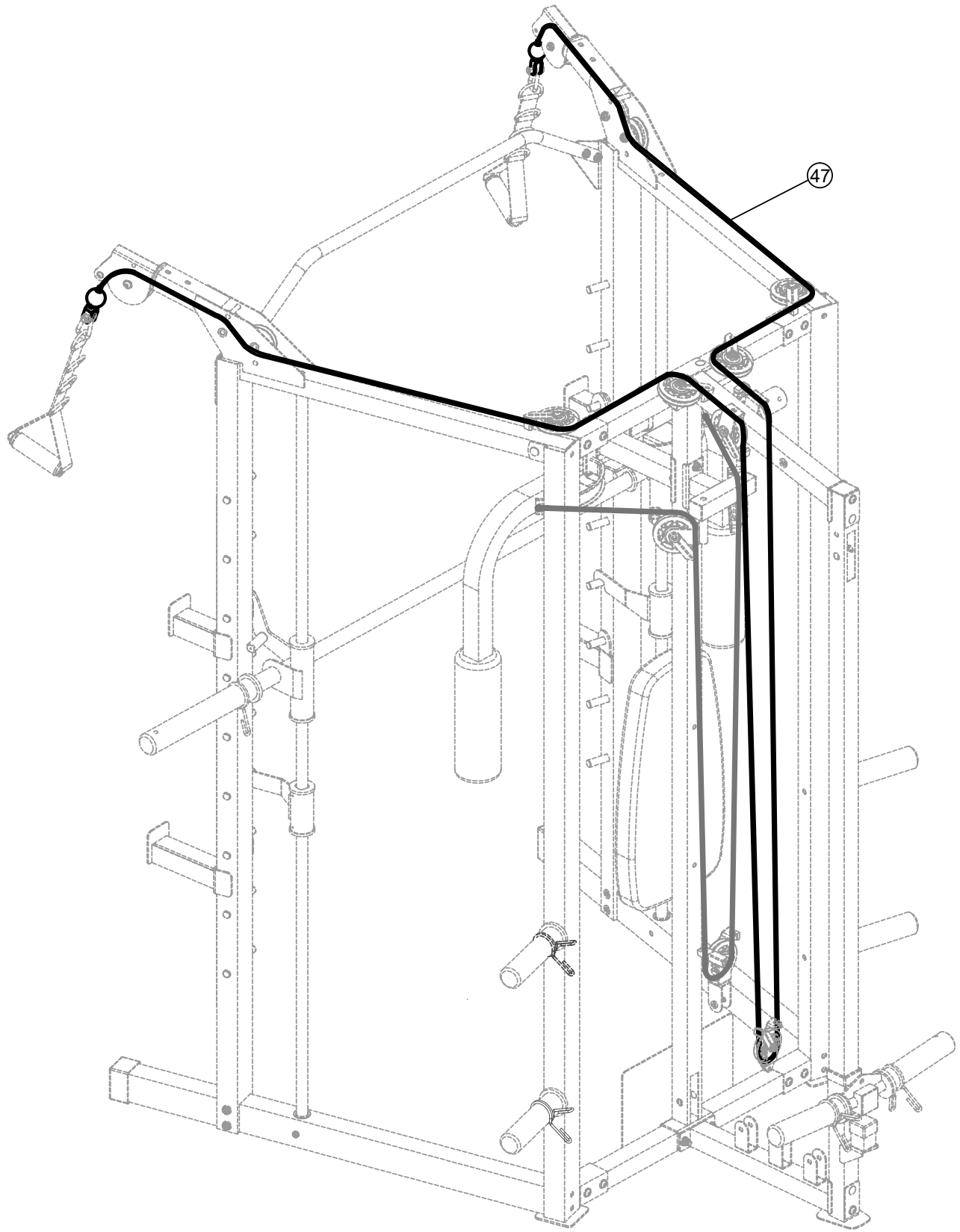

12-C

## **Sliding Weight Post Cable assembly instruction Step-13**

- A.) Attach one end of the 97" Sliding Weight Post Cable (#46) to the triangular bracket on the Sliding Weight post (#23). Secure it with one M10 x  $\frac{3}{4}$ " Allen Bolt (#90), two  $\text{\textcircled{O}} \frac{3}{4}$ " Washers (#107), and one M10 Aircraft Nut (#110).
- B.) Draw the Cable upward to the opening on the Weight Glide Post (#17).
- C.) Attach a Pulley (#62) to the opening. Secure it with one M10 x 2  $\frac{1}{2}$ " Allen Bolt (#95), two  $\text{\textcircled{O}} 1" \times \frac{1}{2}"$  Pulley Bushings (#57), and one M10 Aircraft Nut (#110).
- D.) Draw the Cable around the Pulley and then downward.
- E.) Attach a Pulley to top holes on the two Double Floating Pulley Brackets (#33). Secure the Pulley with one M10 x 2" Allen Bolt (#94), two Cable Retainers (#78), two  $\text{\textcircled{O}} \frac{3}{4}$ " Washers (#107), and one M10 Aircraft Nut (#110).
- F.) Draw the Cable around the Pulley and upward to the opening under the Rear Upper Frame (#18).
- G.) Secure the end of the Cable to the opening with one M10 x 2  $\frac{3}{8}$ " Allen Bolt (#118), two  $\text{\textcircled{O}} \frac{3}{4}$ " Washers (#107), and one M10 Aircraft Nut (#110).

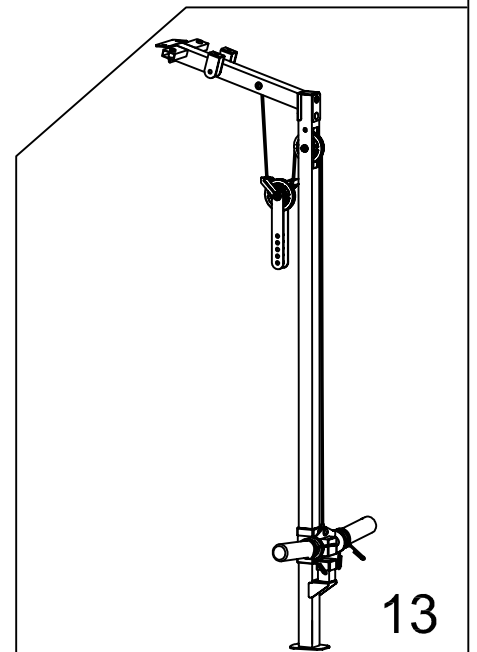
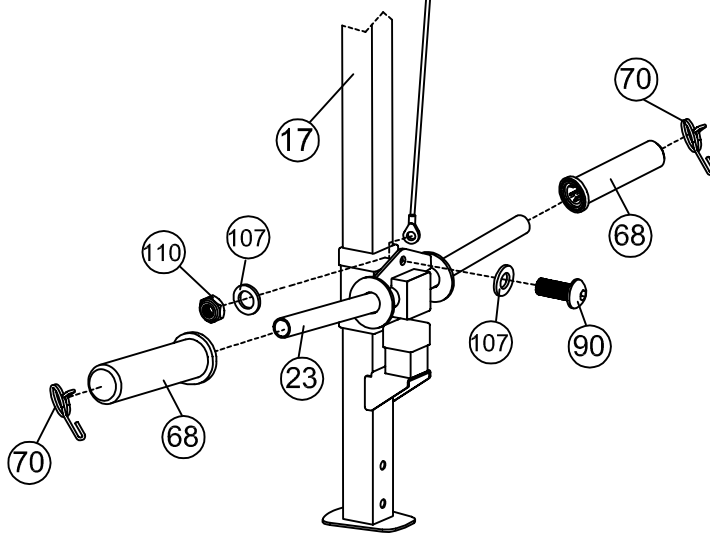
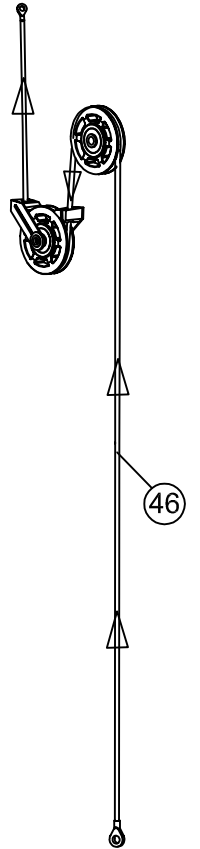
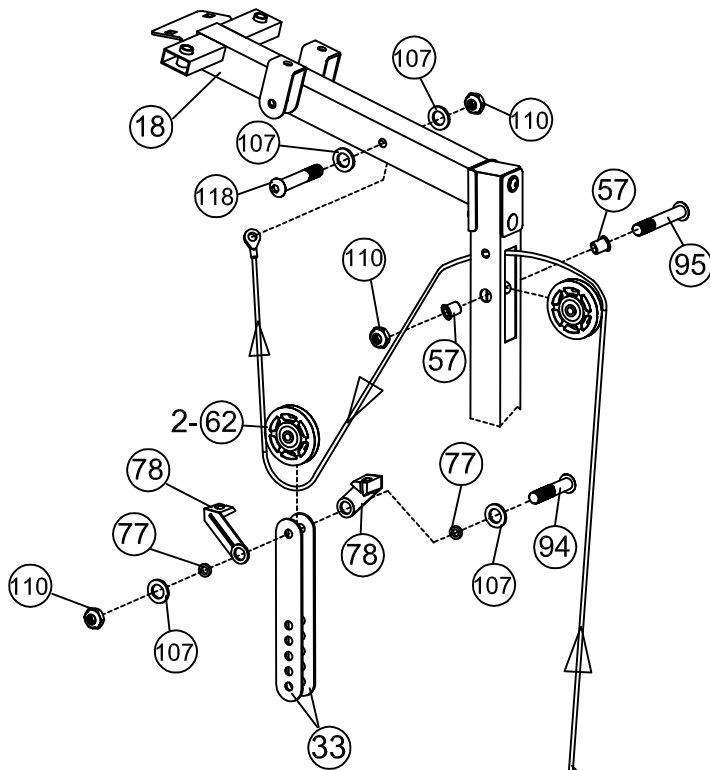
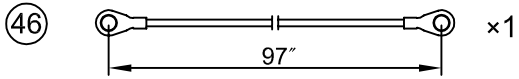

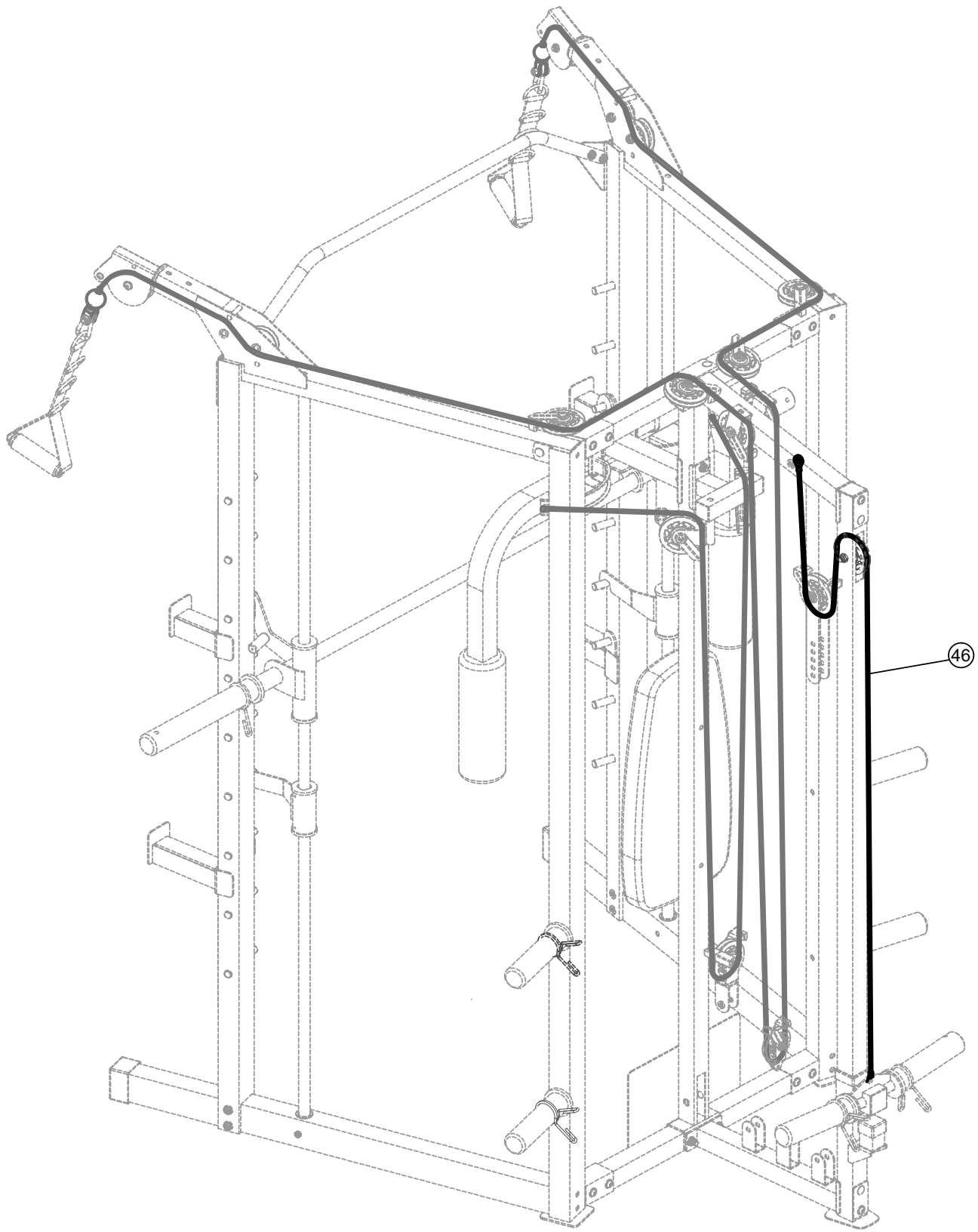

13-A

## **Lower Cable assembly instruction Step-14**

- A. Insert the tip of the 152" Lower Cable (#44) through the opening on Foot Plate (#32) to the opening on bottom of Middle Vertical Frame (#9).
- B. Attach a Pulley (#62) to the opening. Secure it with one M10 x 2 ½" Allen Bolt (#95), two Ø 1" x ½" Pulley Bushings (#57), and one M10 Aircraft Nut (#110).
- C. Draw the Cable to the Angled Floating Pulley Bracket (#52) previously installed in Step-11.
- D. Attach a Pulley to the Bracket. Secure it with one M10 x 2" Allen Bolt (#94), two Ø ¾" Washers (#107), two Cable Retainers (#78), and one M10 Aircraft Nut (#110).
- E. Draw the Cable around the Pulley and then downward to the first open bracket on the Lower Pulley Frame (#16).
- F. Attach a Pulley to the bracket. Secure it with one M10 x 2" Allen Bolt (#94), two Ø ¾" Washers (#107), one Cable Retainer (#78), and one M10 Aircraft Nut (#110).
- G. Draw the Cable under Pulley and through the next open bracket to the third open bracket. Attach a Pulley to the bracket. Secure it with one M10 x 2" Allen Bolt (#94), two Ø ¾" Washers (#107), one Cable Retainer (#78), and one M10 Aircraft Nut (#110).
- H. Draw the Cable around the Pulley and then upward to the Double Floating Pulley Bracket previously installed in Step-13.
- I. Attach a Pulley to the Bracket. Secure it with one M10 x 2" Allen Bolt (#94), two Ø ¾" Washers (#107), two Cable Retainers (#78), and one M10 Aircraft Nut (#110).
- J. Draw the Cable around the Pulley then downward to the open bracket on Lower Pulley Frame.
- K. K.) Attach a Pulley to the bracket. Secure it with one M10 x 2" Allen Bolt (#94), two Ø ¾" Washers (#107), one Cable Retainer (#78), and one M10 Aircraft Nut (#110).
- L. Draw the Cable around the Pulley then upward to the Single Floating Pulley Bracket (#34) previously installed in Step-12A. Secure the Cable to the Bracket with one M10 x 1" Allen Bolt (#91), two Ø ¾" Washers (#107), and one M10 Aircraft Nut (#110).
- M. Move the lower Pulley position on Double Floating Pulley Bracket will adjust the tension of the whole Cable System. Move up the Pulley will increase the tension. Move down the Pulley will loosen the tension.
- N. N.) Attach the Shiver Bar (#54) to the Lower Cable with one 15-link Chain (#72) and two Hooks (#73). Replace the Shiver Bar with Ankle Strap (#75) or Triceps Rope (#53) for various exercises.



44

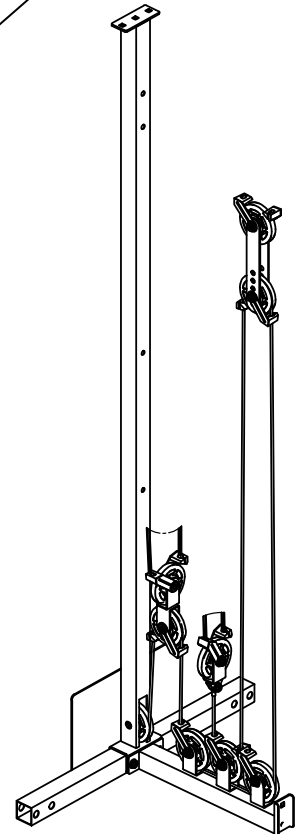
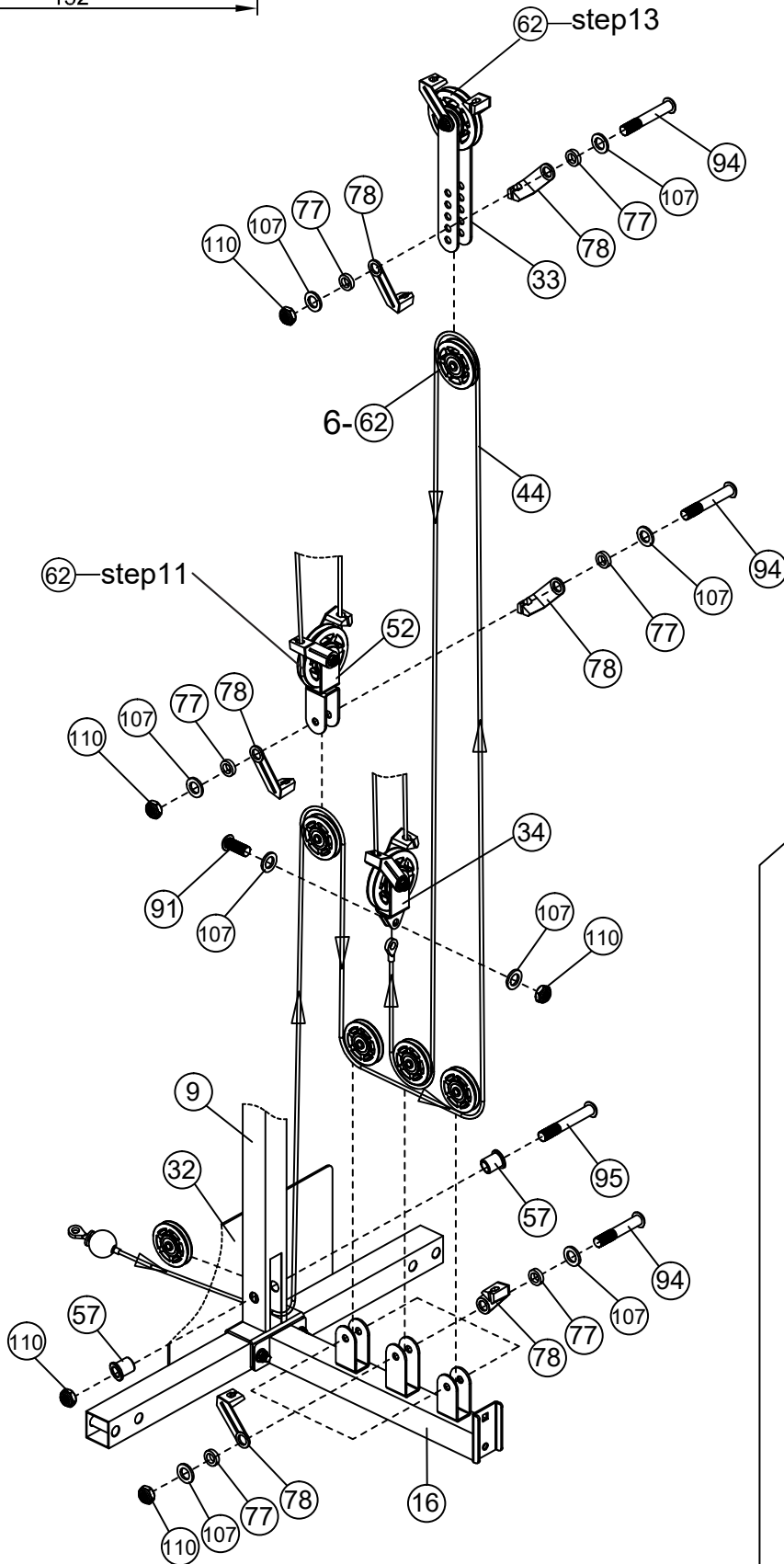
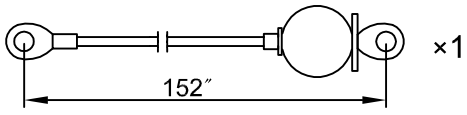

14

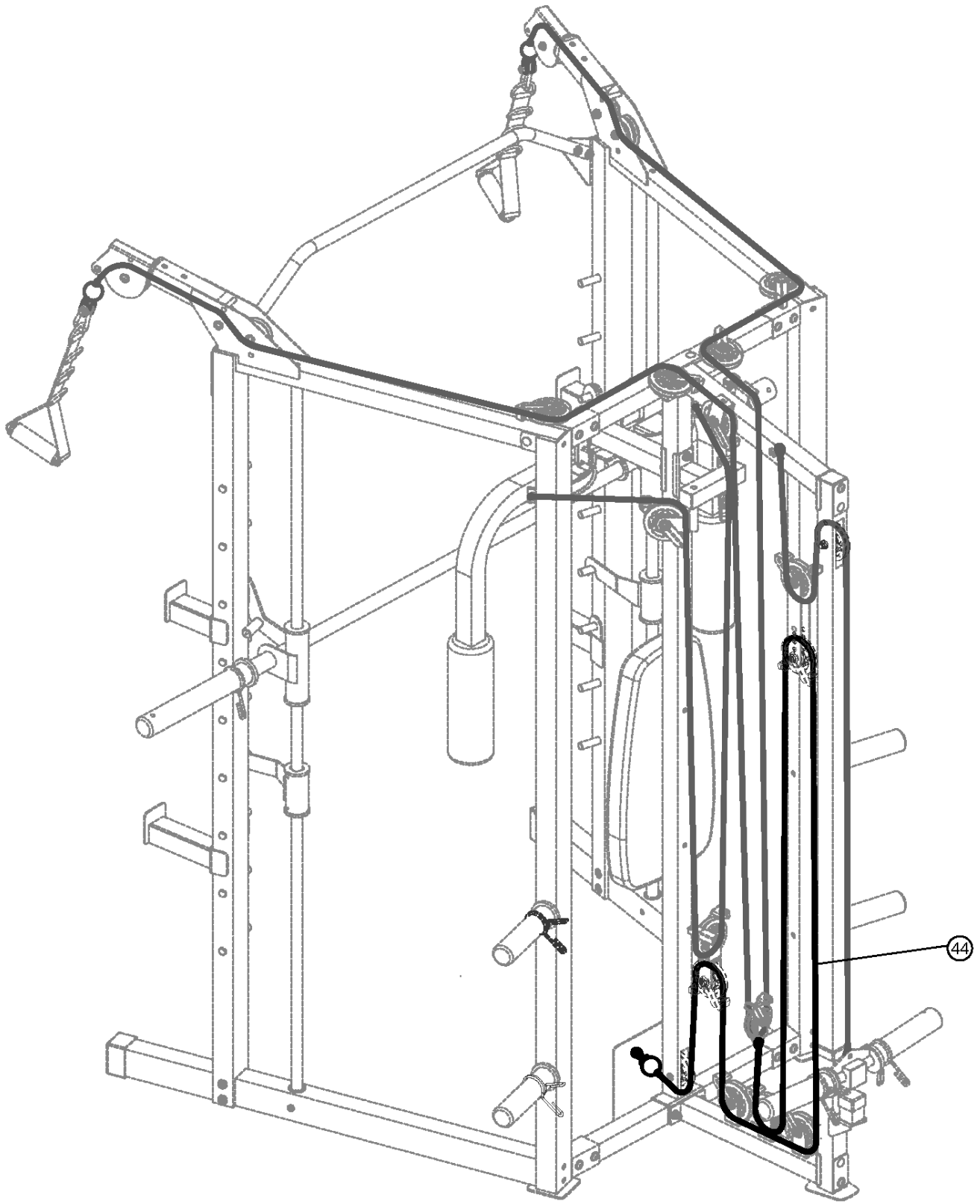

14-A

## WEIGHT CAPACITY AND DIMENSION

1. Maximum user weight: 136 kg.
2. Maximum weight on Sliding Weight Post (#23): 136 kg (68 kg on each side)
3. Maximum weight on storage Weight Post (#38): 45 kg
4. Maximum weight on Bar Holder (#21 & #22) and Safety Catch (#19 & #20): 136 kg
5. Maximum weight on Weight Bar (#29): 136 kg
6. Maximum weight on Bench: 272 kg (including user weights)
7. Cage assembled dimensions: 165 cm x 198 cm x 214 cm
8. Bench assembled dimensions: 173 cm x 66 cm x 115 cm

## CARE AND MAINTENANCE

1. Lubricate moving parts with WD-40 or light oil periodically.
2. Inspect and tighten all parts before using the equipment.
3. The equipment can be cleaned using a damp cloth and mild non-abrasive detergent. DO NOT use solvents.
4. Examine the equipment regularly for signs of damage or wear.
5. Replace any defective components immediately and/or keep the equipment out of use until repair.
6. **Failure to examine regularly may affect the safety level of the equipment.**

## OPERATION NOTES

This equipment should be placed on flat surface. The incline or decline of surface should be limited to 3% or less for best performance and safety.

### Cable Tension Adjustment

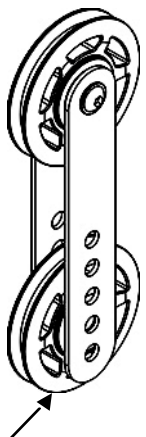

Adjust the tension of the Cable System by moving the position of lower Pulley on the Double Floating Pulley Brackets.

- ↑ If the tension is too loose, move the lower pulley up by one hole. If the tension is too tight, move the lower pulley down by one hole

**Lower Pulley**

## **Bench Backrest Adjustment Angles**

Backrest adjustment angle ranges from  $-18^{\circ}$  to  $71^{\circ}$ .

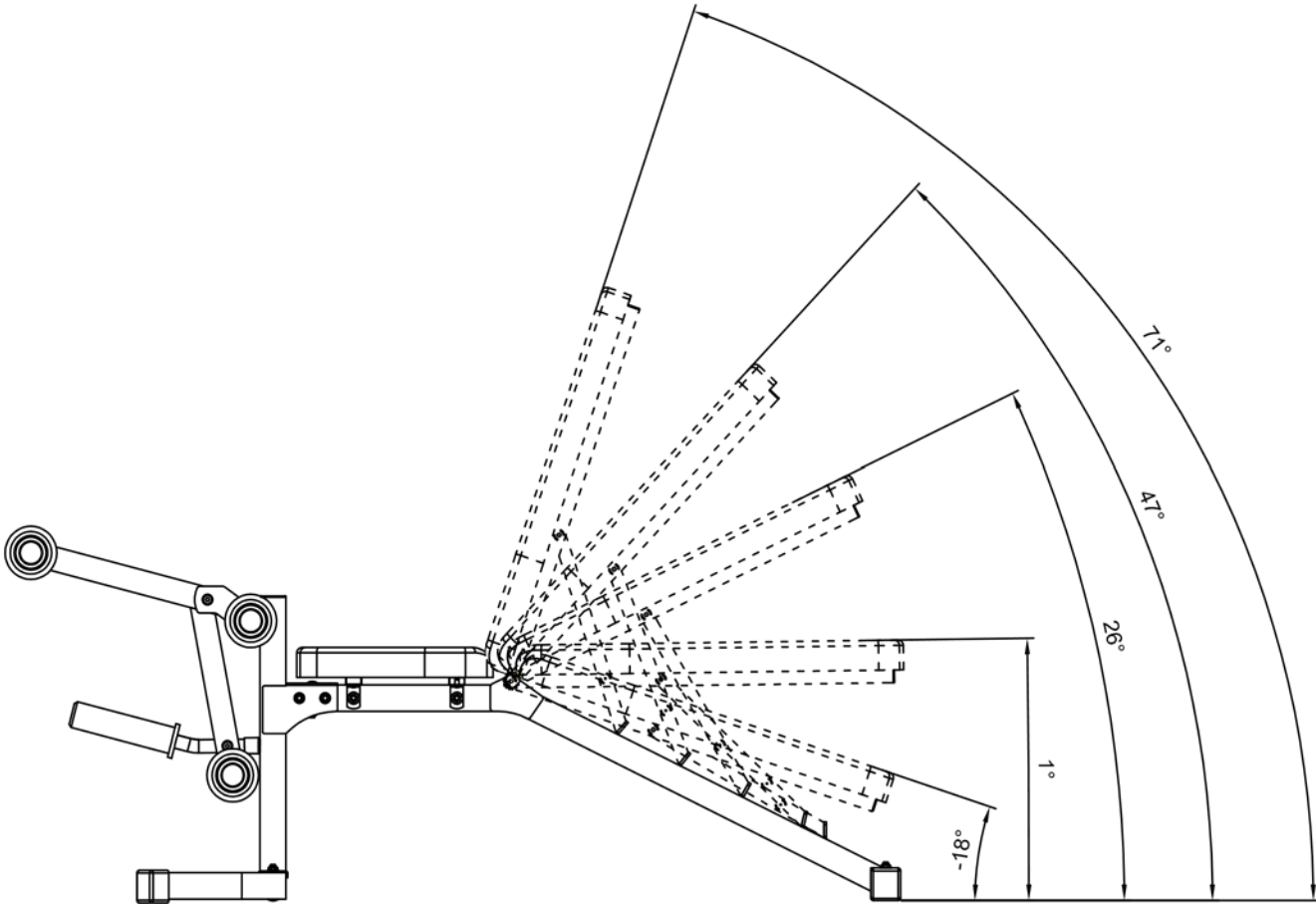

## **SM4008 WEIGHT RESISTANCE CHART**

| <b>Station</b>        | <b>Ratio</b> | <b>Example</b>                           |
|-----------------------|--------------|--|
| Low Pulley            | 100%         | 4.5 kg. plate creates 4.5 kg. resistance |
| Butterfly (both arms) | 100%         | 4.5 kg. plate creates 2.25 kg resistance |
| Left Cross-Over       | 50%          | 4.5 kg. plate creates 2.25 kg resistance |
| Right Cross-Over      | 50%          | 4.5 kg. plate creates 2.25 kg resistance |

**\*Numbers are approximate. Actual resistance may vary.**

## SM4008 CAGE PARTS LIST

| PART NO | DESCRIPTION                      | SIZE              | QUANTITY |
|---------|----------------------------------|-------------------|----------|
| 1       | Front Left Vertical Frame        |                   | 1        |
| 2       | Front Right Vertical Frame       |                   | 1        |
| 3       | Rear Left Vertical Frame         |                   | 1        |
| 4       | Rear Right Vertical Frame        |                   | 1        |
| 5       | Base Frame                       |                   | 2        |
| 6       | Rear Top Beam                    |                   | 1        |
| 7       | Upper Side Frame                 |                   | 2        |
| 8       | Rear Base Frame                  |                   | 1        |
| 9       | Middle Vertical Frame            |                   | 1        |
| 10      | Cross-over Swivel Pulley Bracket |                   | 2        |
| 11      | Butterfly Base                   |                   | 1        |
| 12      | Left Butterfly                   |                   | 1        |
| 13      | Right Butterfly                  |                   | 1        |
| 14      | Butterfly Pulley Bracket         |                   | 1        |
| 15      | Swivel Pulley Bracket            |                   | 2        |
| 16      | Lower Pulley Frame               |                   | 1        |
| 17      | Weight Glide Post                |                   | 1        |
| 18      | Rear Upper Frame                 |                   | 1        |
| 19      | Left Safety Catch                |                   | 1        |
| 20      | Right Safety Catch               |                   | 1        |
| 21      | Left Bar Holder                  |                   | 1        |
| 22      | Right Bar Holder                 |                   | 1        |
| 23      | Sliding Weight Post              |                   | 1        |
| 24      | Guide Rod                        |                   | 2        |
| 25      | Safety Stop Frame                |                   | 2        |
| 26      | Left Lower Safety Stop Frame     |                   | 1        |
| 27      | Right Lower Safety Stop Frame    |                   | 1        |
| 28      | Lifting Sleeve                   |                   | 1        |
| 29      | Weight Bar                       |                   | 1        |
| 30      | Chin-up Bar                      |                   | 1        |
| 31      | Butterfly Stopper                |                   | 1        |
| 32      | Foot Plate                       |                   | 1        |
| 33      | Double Floating Pulley Bracket   |                   | 2        |
| 34      | Single Floating Pulley Bracket   |                   | 1        |
| 35      | Lock Ring                        |                   | 2        |
| 36      | Bracket                          | 3 1/8" x 1 3/4"   | 2        |
| 37      | Rotating Handle                  |                   | 1        |
| 38      | Weight Post                      |                   | 4        |
| 39      | Backrest Board                   |                   | 1        |
| 40      | Rubber Bumper                    | Ø 2 5/8" x 1 1/2" | 2        |
| 41      | Guide Bushing                    | Ø 1 1/2" x 1"     | 2        |

|    |                                |               |    |
|----|--------------------------------|---------------|----|
| 42 | Cable Roller                   |               | 2  |
| 43 | Upper Cable Sleeve             |               | 2  |
| 44 | Lower Cable                    | 152"          | 1  |
| 45 | Butterfly Cable                | 113"          | 1  |
| 46 | Sliding Weight Post Cable      | 97"           | 1  |
| 47 | Upper Cable                    | 261"          | 1  |
| 48 | Base Frame End Cap             | 2 ¾" x 2"     | 2  |
| 49 | Left Chin-up Bracket           |               | 1  |
| 50 | Right Chin-up Bracket          |               | 1  |
| 51 | Front Vertical Frame Panel     |               | 2  |
| 52 | Angled Floating Pulley Bracket |               | 1  |
| 53 | Triceps Rope                   |               | 1  |
| 54 | Shiver Bar                     |               | 1  |
| 55 | Rotate Ring                    |               | 4  |
| 56 | Bushing                        | Ø 1 ½" x 7/8" | 4  |
| 57 | Pulley Bushing                 | Ø 1" x ½"     | 4  |
| 58 | Allen Bolt                     | M6 x ¾"       | 2  |
| 59 | Spacer                         | Ø 1 ½" x Ø ½" | 1  |
| 60 | End Cap                        | 1 5/8" x ¾"   | 2  |
| 61 | Square End Cap                 | 1 ½" x 1 ½"   | 1  |
| 62 | Pulley                         |               | 20 |
| 63 | Small Pulley                   |               | 4  |
| 64 | Butterfly Arm Foam Roll        |               | 2  |
| 65 | Square End Cap                 | 1 ¾" x 1 ¾"   | 5  |
| 66 | Left Safety Rubber Bumper      |               | 1  |
| 67 | Right Holder Rubber Bumper     |               | 1  |
| 68 | Weight Post Olympic Sleeve     |               | 6  |
| 69 | Weight Bar Olympic Sleeve      |               | 2  |
| 70 | Spring Clip                    |               | 8  |
| 71 | End Cap                        | 2" x 1 ¾"     | 2  |
| 72 | Chain                          | 15-link       | 1  |
| 73 | Hook                           |               | 4  |
| 74 | Rivet                          |               | 24 |
| 75 | Ankle Strap                    |               | 1  |
| 76 | Grip                           | 6"            | 2  |
| 77 | Cable Retainer Bushing         |               | 24 |
| 78 | Cable Retainer                 |               | 24 |
| 79 | Single Handle                  |               | 2  |
| 80 | Sleeve                         | Ø 2" x 1 5/8" | 8  |
| 81 | End Cap                        | Ø 5/8"        | 36 |
| 82 | End Cap                        | Ø ¾"          | 2  |
| 83 | End Cap                        | Ø ¾" x 2"     | 2  |
| 84 | End Cap                        | Ø 1"          | 8  |

|     |                            |            |     |
|-----|----------------------------|------------|-----|
| 85  | End Cap                    | Ø 1 ½"     | 2   |
| 86  | Carriage Bolt              | M10 x 1 ⅝" | 4   |
| 87  | Allen Bolt                 | M10 x ⅝"   | 4   |
| 88  | Carriage Bolt              | M10 x 2 ½" | 8   |
| 89  | Carriage Bolt              | M10 x 3"   | 2   |
| 90  | Allen Bolt                 | M10 x ¾"   | 15  |
| 91  | Allen Bolt                 | M10 x 1"   | 1   |
| 92  | Allen Bolt                 | M10 x 1 ⅛" | 2   |
| 93  | Allen Bolt                 | M10 x 1 ¾" | 4   |
| 94  | Allen Bolt                 | M10 x 2"   | 10  |
| 95  | Allen Bolt                 | M10 x 2 ½" | 12  |
| 96  | Allen Screw                | M8 x ¼"    | 4   |
| 97  | Allen Bolt                 | M10 x 2 ¾" | 6   |
| 98  | Allen Bolt                 | M10 x 3 ⅛" | 4   |
| 99  | Allen Bolt                 | M10 x 5"   | 1   |
| 100 | Hex Bolt                   | M12 x 5"   | 2   |
| 101 | Allen Bolt                 | M8 x ⅜"    | 8   |
| 102 | Allen Bolt                 | M8 x 1 ⅝"  | 2   |
| 103 | Allen Bolt                 | M8 x 2 ⅜"  | 4   |
| 104 | Allen Screw                | M8 x ⅜"    | 4   |
| 105 | Philips Screw              | ST4.0      | 16  |
| 106 | Washer                     | Ø ⅝"       | 18  |
| 107 | Washer                     | Ø ¾"       | 104 |
| 108 | Washer                     | Ø 1"       | 4   |
| 109 | Aircraft Nut               | M8         | 4   |
| 110 | Aircraft Nut               | M10        | 52  |
| 111 | Aircraft Nut               | M12        | 2   |
| 112 | Plastic Ring               |            | 2   |
| 113 | V-Bar                      |            | 1   |
| 114 | Right Safety Rubber Bumper |            | 1   |
| 115 | Right Holder Rubber Bumper |            | 1   |
| 116 | Cone-shaped End Cap        | Ø 1"       | 4   |
| 117 | Square End Cap             | 2" x 2"    | 1   |
| 118 | Allen Bolt                 | M10 x 2 ⅜" | 1   |

# SM4008 CAGE EXPLODED DIAGRAM

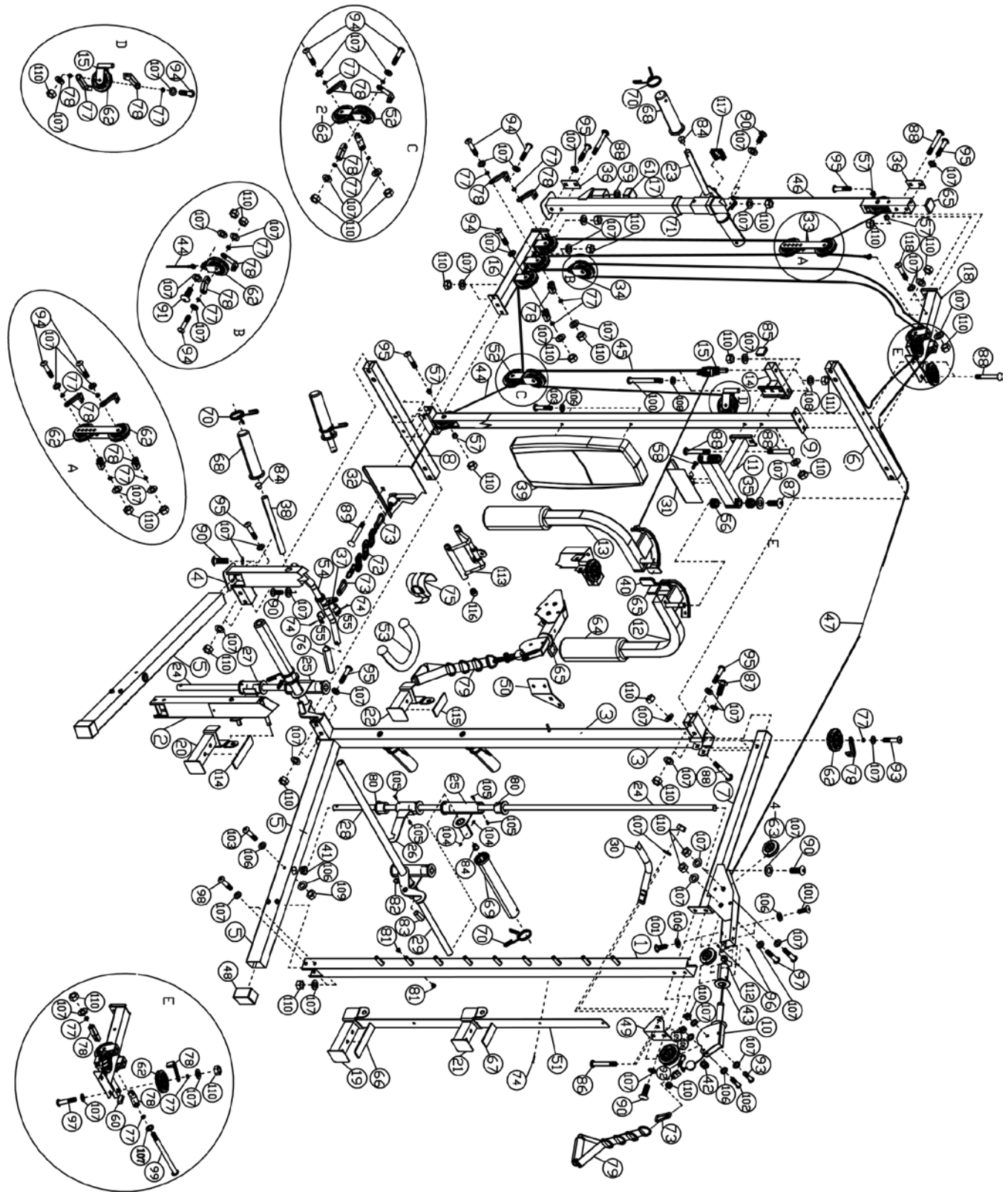



## SM4008 BENCH PARTS LIST

| PART NO | DESCRIPTION               | SIZE              | QUANTITY |
|---------|---------------------------|-------------------|----------|
| 1       | Main Frame                |                   | 1        |
| 2       | Front Post                |                   | 1        |
| 3       | Rear Stabilizer           |                   | 1        |
| 4       | Seat Bracket              |                   | 2        |
| 5       | Leg Developer             |                   | 1        |
| 6       | Leg Developer Weight Post |                   | 1        |
| 7       | Backrest Support          |                   | 2        |
| 8       | Incline Support           |                   | 1        |
| 9       | Front Stabilizer          |                   | 1        |
| 10      | Seat Pad                  |                   | 1        |
| 11      | Backrest Board            |                   | 1        |
| 12      | End Cap                   | 5/8" x 1 1/8"     | 4        |
| 13      | Foam Tube                 |                   | 3        |
| 14      | Foam Roll                 |                   | 6        |
| 15      | Olympic Sleeve            |                   | 1        |
| 16      | Foam Roll End Cap         |                   | 6        |
| 17      | Square End Cap            | 2" x 2"           | 4        |
| 18      | Square End Cap            | 1 3/4" x 1 3/4"   | 3        |
| 19      | Flat End Cap              | 2"                | 1        |
| 20      | Rubber Bumper             | Ø 1 1/8" x 1 1/8" | 1        |
| 21      | Spring Clip               |                   | 1        |
| 22      | Square End Cap            | 1" x 1"           | 2        |
| 23      | Incline Support Grip      |                   | 1        |
| 24      | Bushing                   | Ø 3/4"            | 4        |
| 25      | Carriage Bolt             | M10 x 2 3/4"      | 2        |
| 26      | Allen Bolt                | M10 x 6 7/8"      | 2        |
| 27      | Allen Bolt                | M8 x 2 3/4"       | 2        |
| 28      | Carriage Bolt             | M10 x 2 1/2"      | 5        |
| 29      | Allen Bolt                | M10 x 3"          | 1        |
| 30      | Allen Bolt                | M10 x 2 3/8"      | 1        |
| 31      | Allen Bolt                | M8 x 1 1/8"       | 4        |
| 32      | Allen Bolt                | M8 x 1 5/8"       | 4        |
| 33      | Aircraft Nut              | M8                | 2        |
| 34      | End Cap                   | Ø 1"              | 1        |
| 35      | Washer                    | Ø 3/4"            | 15       |
| 36      | Washer                    | Ø 5/8"            | 12       |
| 37      | Aircraft Nut              | M10               | 11       |
| 38      | Washer                    | Ø 1" x Ø 3/8"     | 1        |
|         | Allen Wench (Tool)        | 6#                | 1        |
|         | Allen Wrench (Tool)       | 5#                | 1        |

# BENCH EXPLODED DIAGRAM

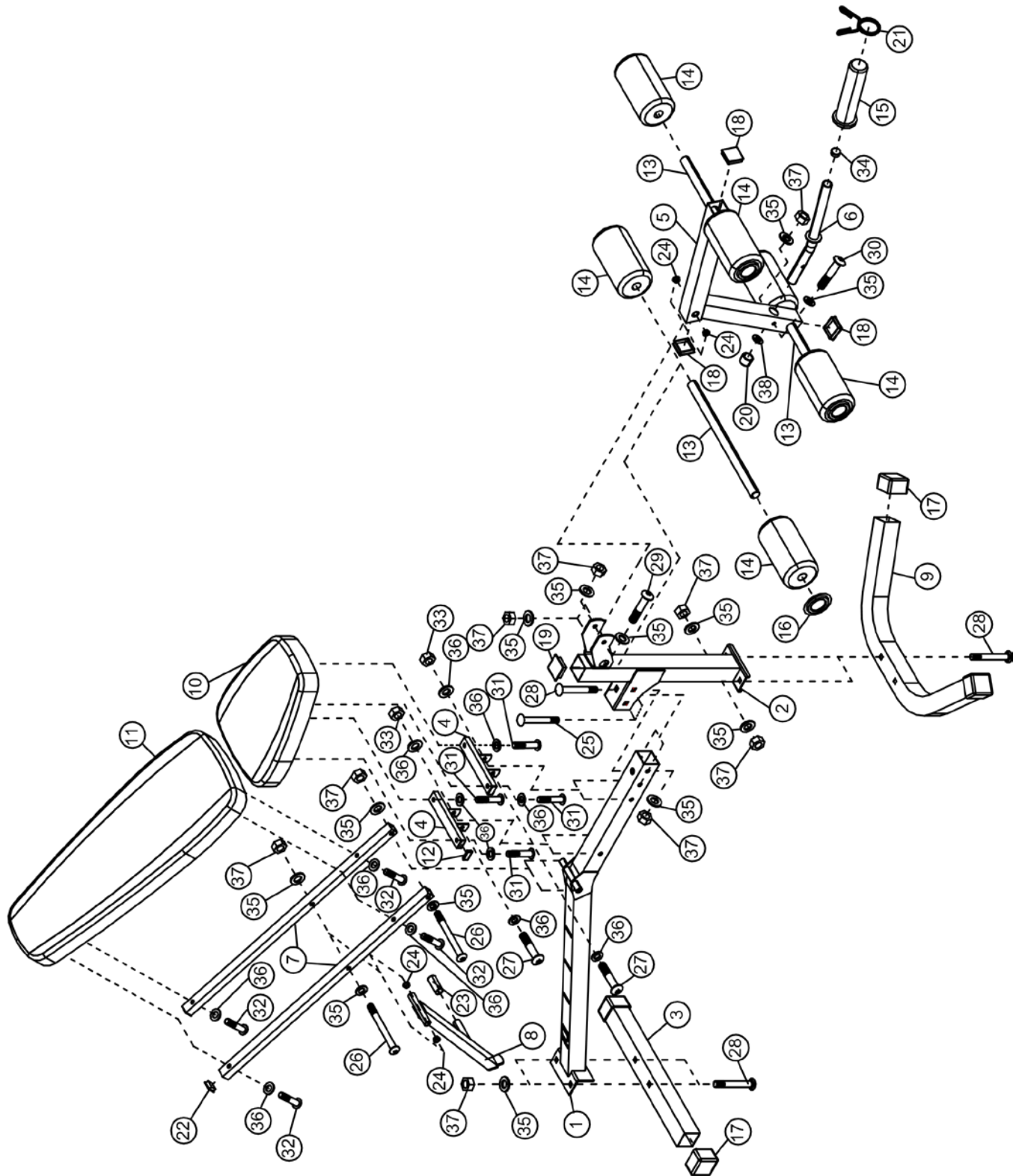

# LIMITED WARRANTY

Puretec Ltd warrants this product to be free from defects in workmanship and material, under normal use and service conditions. Please refer to [www.puretecfitness.com](http://www.puretecfitness.com) for warranty terms. This warranty extends only to the original purchaser and is valid for home use only. Puretec Ltd's obligation under this Warranty is limited to replacing damaged or faulty parts at Puretec Ltd's option.

All returns must be pre-authorized by Puretec Ltd. This warranty does not extend to any product or damage to a product caused by or attributable to freight damage, abuse, misuse, improper or abnormal usage, purchasers own repairs or for products used for commercial or rental purposes. No other warranty beyond that specifically set forth above is authorized by Puretec Ltd.

Puretec Ltd is not responsible or liable for indirect, special or consequential damages arising out of or in connection with the use or performance of the product or other damages with respect to any economic loss, loss of property, loss of revenues or profits, loss of enjoyments or use, costs of removal, installation or other consequential damages or whatsoever natures.

The warranty extended hereunder is in lieu of any and all other warranties and any implied warranties of merchantability or fitness for a particular purpose is limited in its scope and duration to the terms set forth herein.

Your statutory rights are not affected.

## **ORDERING REPLACEMENT PARTS**

Replacement parts can be ordered by contacting our Customer Solutions Department:

**Pure-Tec Limited**  
**[www.puretecfitness.com](http://www.puretecfitness.com)**

**Email: [service@puretecfitness.com](mailto:service@puretecfitness.com)**

When ordering replacement parts, please give the following information,

1. Model
2. Description of Parts
3. Part Number
4. Date of Purchase