

NOTE:
Please read all instructions
carefully before using this
product

Table of Contents
Safety Notice
Hardware Pack
Assembly Instruction
Exploded Diagram
Parts List
Warranty
Ordering Parts

Model
SB-670

Retain This
Manual for
Reference

07/23/09

**OWNER'S
MANUAL**

IMPEX

MARCY[®] Multi Purpose Bench SB-670

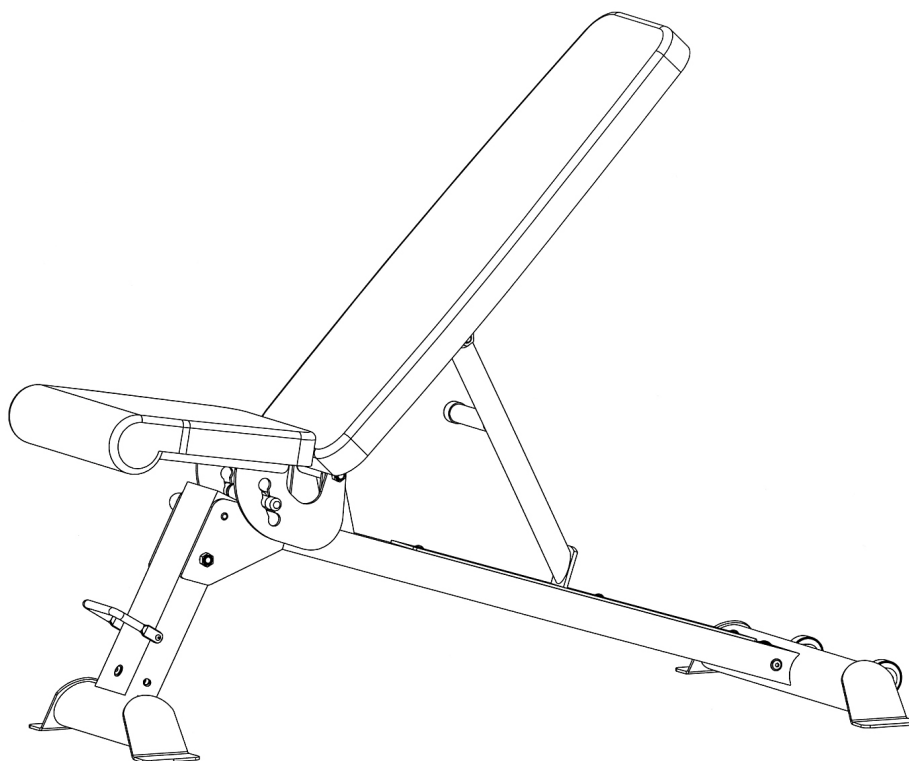

IMPEX[®] Inc.

14777 DON JULIAN RD.,
CITY OF INDUSTRY, CA 91746
Tel: (800) 999-8899 Fax: (626) 961-9966
www.impex-fitness.com
info@impex-fitness.com

TABLE OF CONTENTS

BEFORE YOU BEGIN.....	1
IMPORTANT SAFETY NOTICE.....	2
HARDWARE PACK.....	4
ASSEMBLY INSTRUCTIONS.....	5
EXPLODED DIAGRAM.....	8
PARTS LIST.....	9
WARRANTY.....	10
ORDERING PARTS.....	10

BEFORE YOU BEGIN

Thank you for selecting the **MARCY MULTI PURPOSE BENCH SB-670** by **IMEX INC.** For your safety and benefit, read this manual carefully before using the machine. As a manufacturer, we are committed to provide you complete customer satisfaction. If you have any questions, or find there are missing or damaged parts, we guarantee your complete satisfaction through direct assistance from our factory. To avoid unnecessary delays, *please call our TOLL-FREE customer service number.* Our Customer Service Agents will provide immediate assistance to you.

Toll-Free Customer Service Number

1-800-999-8899

Mon. - Fri. 9 a.m. - 5 p.m. PST

www.impex-fitness.com

info@impex-fitness.com

IMPORTANT SAFETY NOTICE

PRECAUTIONS

This exercise machine is built for optimum safety. However, certain precautions apply whenever you operate a piece of exercise equipment. Be sure to read the entire manual before you assemble or operate your machine. In particular, note the following safety precautions:

1. Keep children and pets away from the machine at all times. DO NOT leave children unattended in the same room with the machine.
2. Only one person at a time should use the machine.
3. If the user experiences dizziness, nausea, chest pain, or any other abnormal symptoms, STOP the workout at once. CONSULT A PHYSICIAN IMMEDIATELY.
4. Position the machine on a clear, leveled surface. DO NOT use the machine near water or outdoors.
5. Keep hands away from all moving parts.
6. Always wear appropriate workout clothing when exercising. DO NOT wear robes or other clothing that could become caught in the machine. Running or aerobic shoes are also required when using the machine.
7. Use the machine only for its intended use as described in this manual. DO NOT use attachments not recommended by the manufacturer.
8. Do not place any sharp object around the machine.
9. Disabled person should not use the machine without a qualified person or physician in attendance.
10. Before using the machine to exercise, always do stretching exercises to properly warm up.
11. Never operate the machine if the machine is not functioning properly.
12. A spotter is recommended during exercise.
13. Maximum user's weight: 300 lbs.

CARE AND MAINTENANCE

1. Inspect and tighten all parts before using the machine.
2. The machine can be cleaned using a damp cloth and mild non-abrasive detergent. DO NOT use solvents.

WARNING: BEFORE BEGINNING ANY EXERCISE PROGRAM, CONSULT YOUR PHYSICIAN. THIS IS ESPECIALLY IMPORTANT FOR INDIVIDUALS OVER THE AGE OF 35 OR PERSONS WITH PRE-EXISTING HEALTH PROBLEMS. READ ALL INSTRUCTIONS BEFORE USING ANY FITNESS EQUIPMENT. IMPEX ASSUMES NO RESPONSIBILITY FOR PERSONAL INJURY OR PROPERTY DAMAGE SUSTAINED BY OR THROUGH THE USE OF THIS PRODUCT.

SAVE THESE INSTRUCTIONS.

WARNING LABEL PLACEMENT

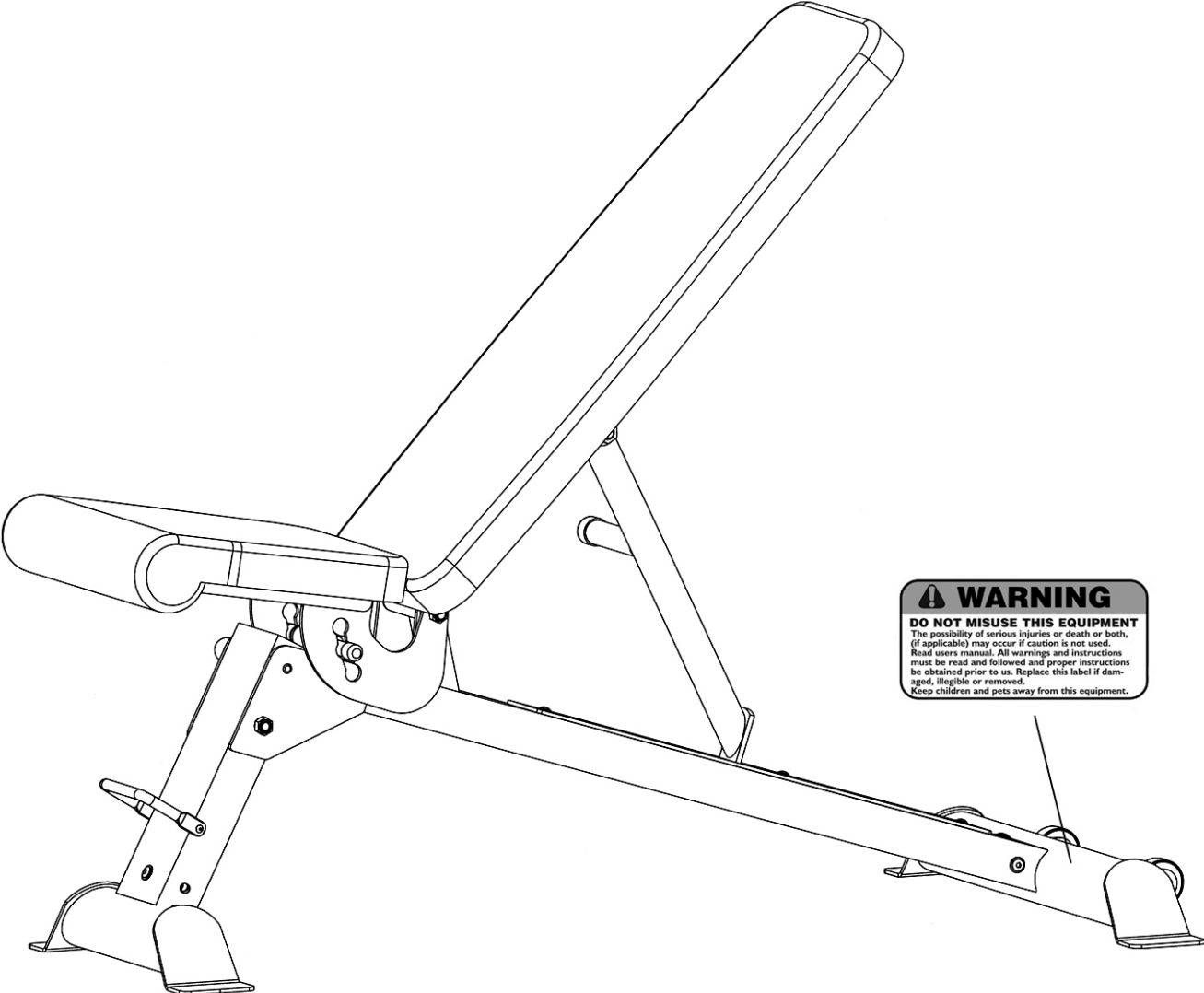

The Warning Label shown here has been placed on the Rear Stabilizer. If the label is missing or illegible, please call customer service at 1-800-999-8899 for replacement. Apply the label in location shown

HARDWARE PACK

NOTE: The following parts are not drawn to scale. Please use your own ruler to measure the size.



#13 M6 x $\frac{5}{8}$ " Allen Bolt (Qty 2)

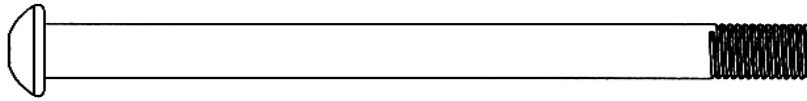

#21 M10 x 4 $\frac{3}{4}$ " Allen Bolt (Qty 1)

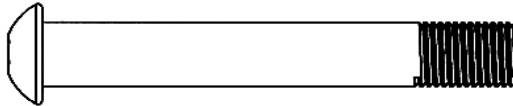

#22 M12 x 3" Allen Bolt (Qty 1)



#23 M10 x $\frac{5}{8}$ " Allen Bolt (Qty 6)



#25 M6 x $\frac{3}{4}$ " Allen Bolt (Qty 4)

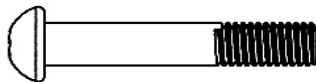

#26 M8 1 x $\frac{3}{4}$ " Allen Bolt (Qty 2)



#28 M12 Aircraft Nut (Qty 1)



#29 M10 Aircraft Nut (Qty 3)

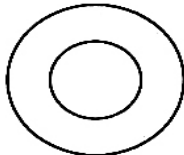

#30 \varnothing 1" Washer (Qty 2)

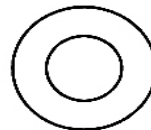

#31 \varnothing $\frac{3}{4}$ " Washer (Qty 10)



#32 \varnothing $\frac{5}{8}$ " Washer (Qty 13)



#33 \varnothing $\frac{1}{2}$ " Washer (Qty 4)

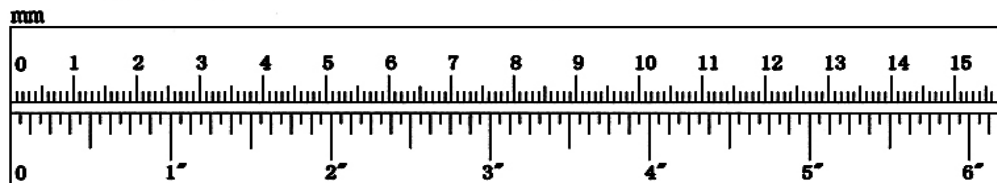

ASSEMBLY INSTRUCTION

Tools Required For Assembling the Machine: Two Adjustable Wrenches and Allen Wrenches. NOTE: It is strongly recommended for two or more people to assemble this machine to avoid possible injury.

STEP 1 (See Diagram 1)

- A.) **Do not tighten Nuts and Bolts until instructed to do so.**
- B.) Attach the Front Post (#4) to the Front Stabilizer (#3). Secure it with three M10 x 5/8" Allen Bolts (#23) and three $\text{\O} \frac{3}{4}$ " Washers (#31).
- C.) Attach the Main Seat Support (#1) to Front Post. Secure the lower hole with one M10 x 4 $\frac{3}{4}$ " Allen Bolt (#21), two $\text{\O} \frac{3}{4}$ " Washers (#31), and one M10 Aircraft Nuts (#29). Secure the upper hole with a Lock Pin (#11) into the upper hole.
- D.) Attach the Main Seat Support to the Rear Stabilizer (#2). Secure it with three M10 x 5/8" Allen Bolts (#23) and three $\text{\O} \frac{3}{4}$ " Washers (#31).
- E.) **Securely tighten all nuts and bolts.**
- F.) Attach the Handle (#12) to the Front Post. Secure it with two M6 x 5/8" Allen Bolts (#13).
- G.) Fold the Front Post by pulling out the Lock Pin (#11), fold down the Front Post, and then reinsert the Lock Pin.

DIAGRAM 1

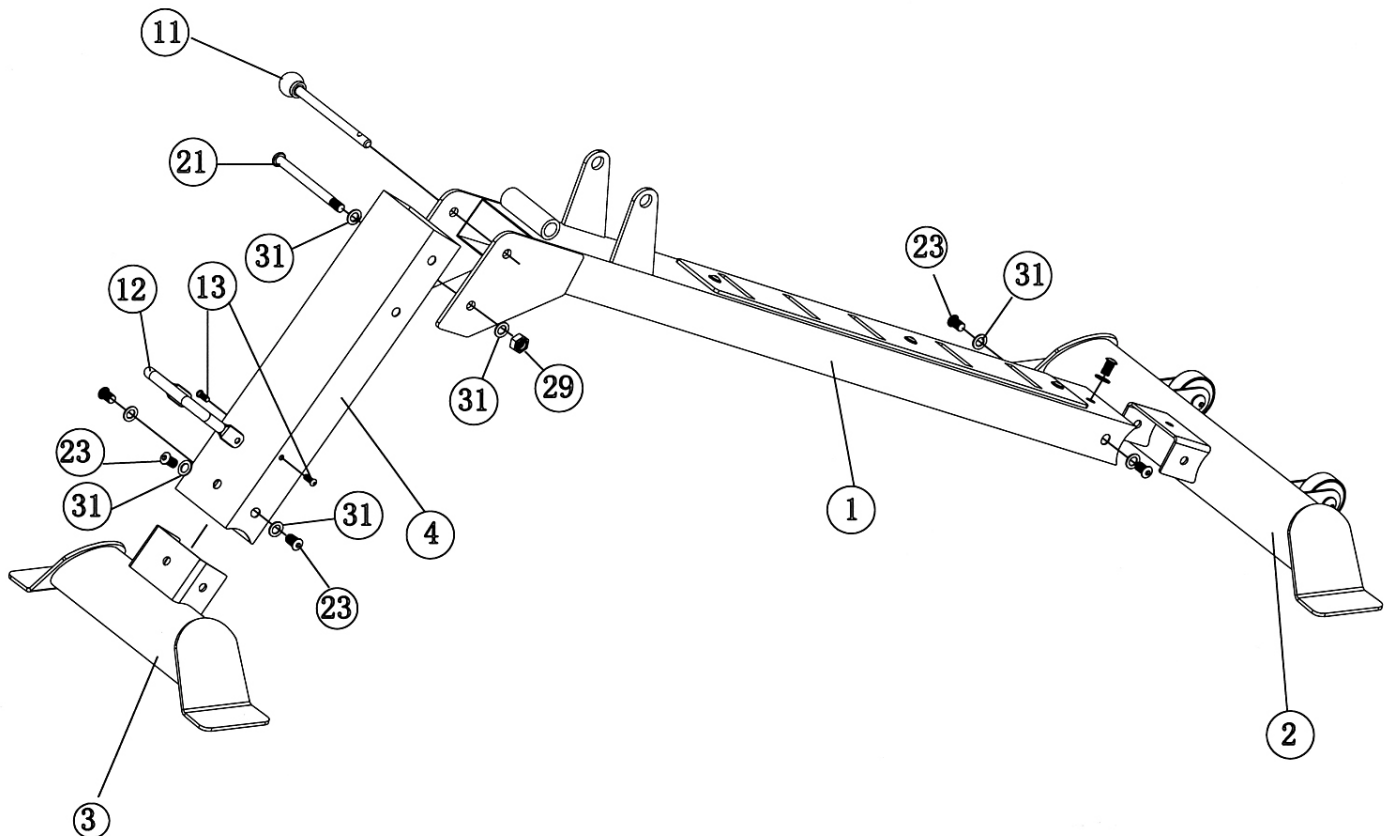

STEP 2 (See Diagram 2)

- A.) Attach the two $\text{Ø } 5/8'' \times \text{Ø } 1''$ Bushings (#19) to the holes on the open bracket on the Main Seat Support (#1). Attach the Left & Right Seat Bracket (#5 & #6) to the open bracket. Attach the pivot on the Backrest Support (#7) inside the opening.
- B.) Align the holes. Secure them together with one Axle (#10), two $\text{Ø } 3/4''$ Washers (#31), and two M10 Aircraft Nuts (#29). **Do not over tighten the Nuts. Make sure the Backrest Support can swivel freely.**
- C.) Remove the T-shaped head from the T-shaped Pull Pin (#9). Remove the Nut from the Pull Pin.
- D.) Insert the Spring and the Pull Pin through the open slot on Left Seat Bracket (#5) and through the pivot on Main Seat Support. Thread back the Nut to the Pull Pin, push the Pull Pin through the open slot on the Right Seat Bracket (#6). Thread the T-shaped head back to the Pull Pin. Pull the T-shaped Pull Pin, and then adjust the Seat bracket to desired position, and then release the Pull Pin to lock the Seat Brackets in position.
- E.) Attach the pivot on the Incline Support (#8) to the open bracket on the back of Backrest Support. Secure it with one M12 x 3" Allen Bolt (#22), two $\text{Ø } 1''$ Washers (#30), and one M12 Aircraft Nut (#28). **Do not over tighten the Nut and Bolt. Make sure the Incline Support can swivel freely.**

DIAGRAM 2

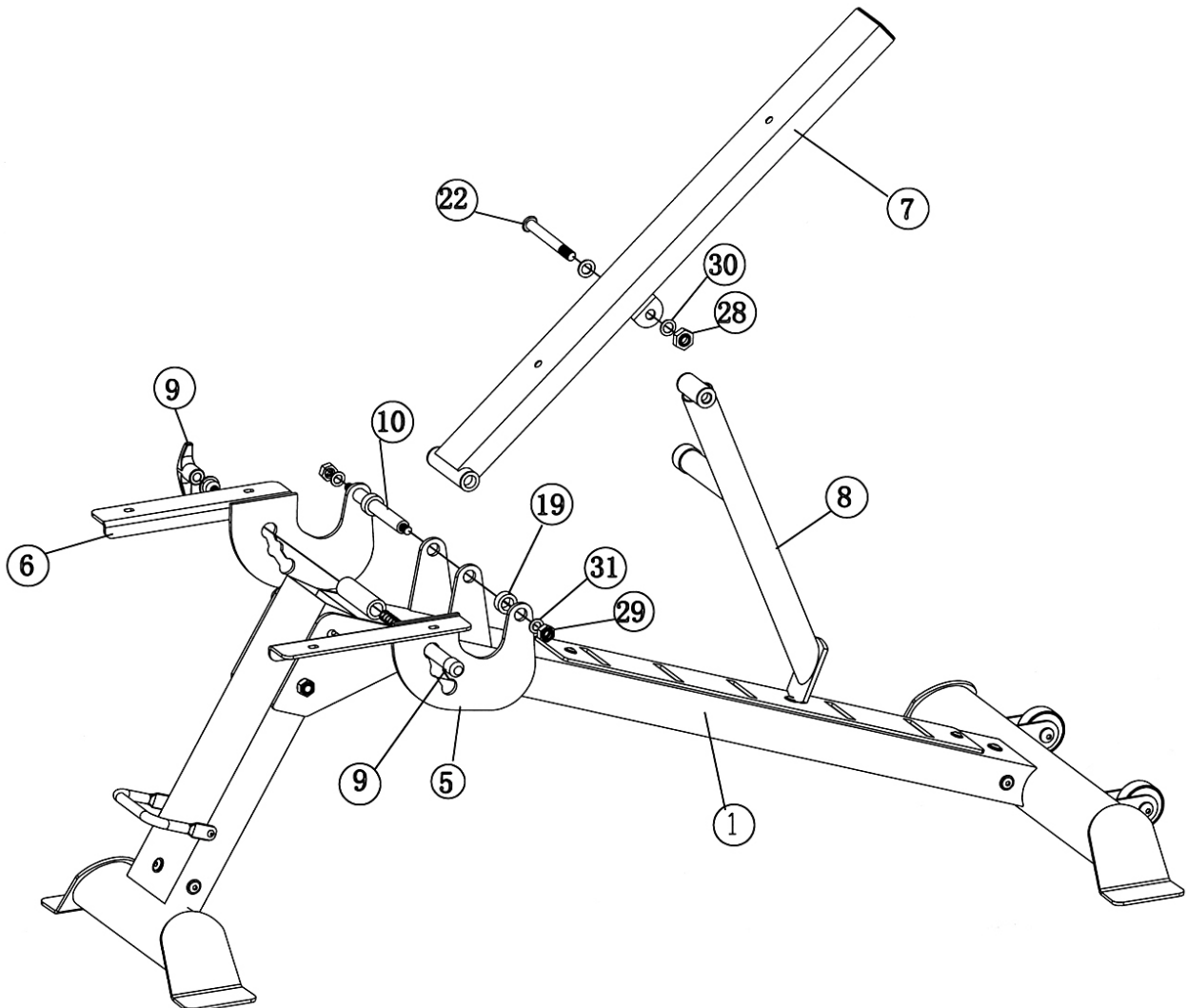

STEP 3 (See Diagram 3)

- A.) Attach the Seat Pad to the Left & Right Seat Bracket (#5 & #6). Secure them with four M6 x 3/4" Allen Bolts (#25) and four Ø 1/2" Washers (#33).
- B.) Attach the Backrest Board to the Backrest Support (#7). Secure it with two M8 x 1 3/4" Allen Bolts (#26) and two Ø 5/8" Washers (#32).
- C.) Use the handle on Incline Support (#8) to move the Incline Support to selected open slot on Main Seat Support (#1) to obtain the desired Backrest Incline.

DIAGRAM 3

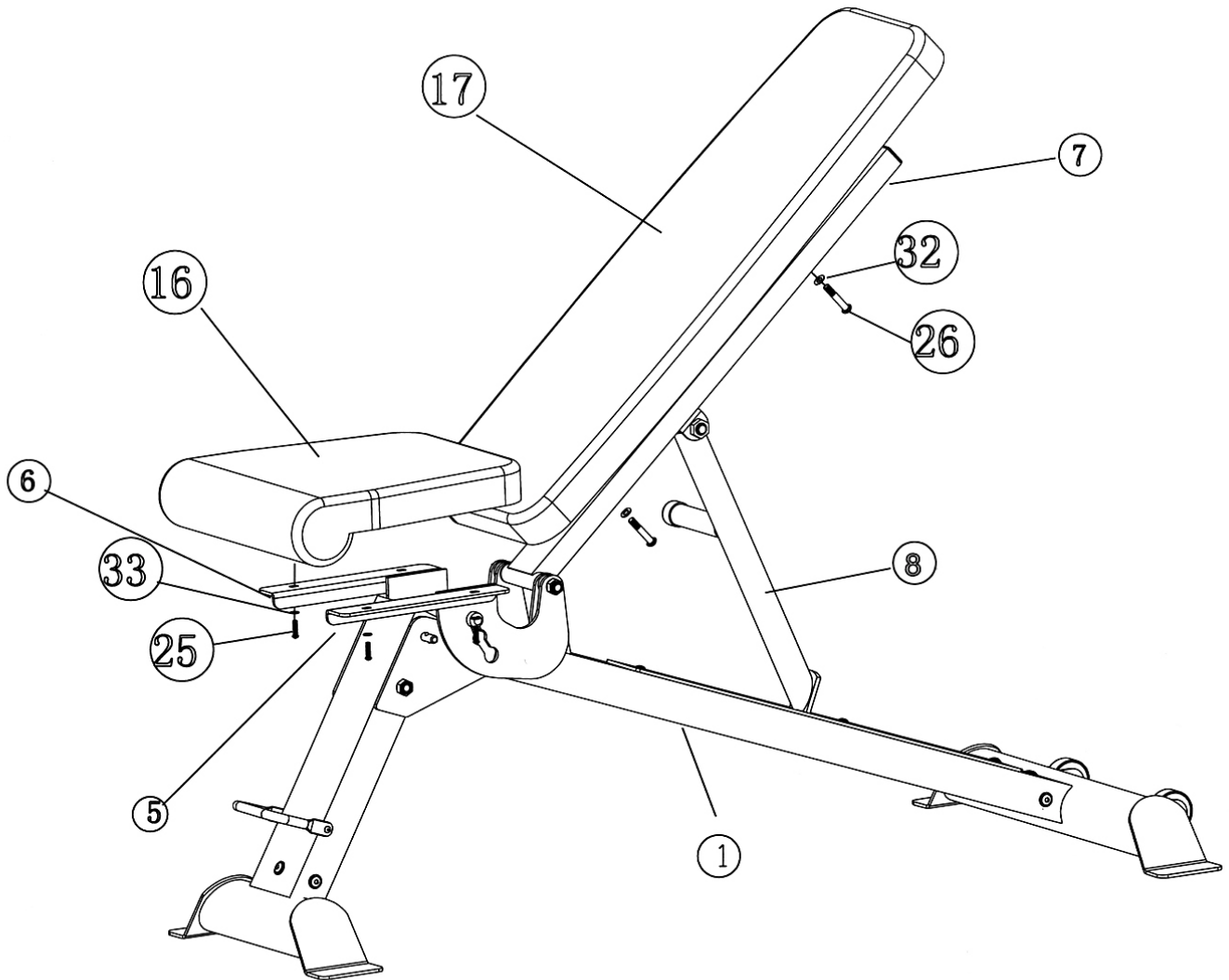

EXPLODED DIAGRAM

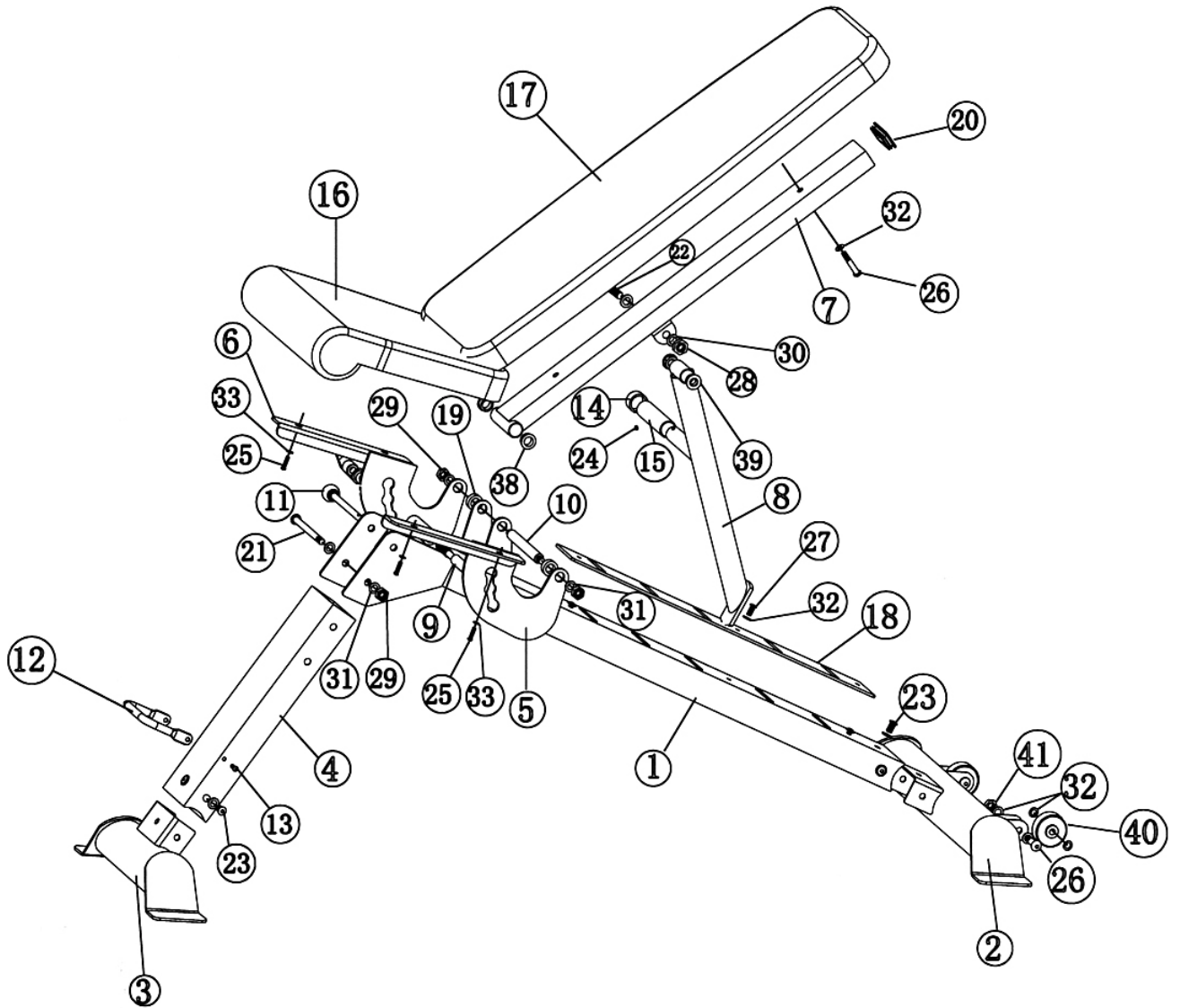

PARTS LIST
KEY NO.

KEY NO.	DESCRIPTION	QUANTITY
1	Main Seat Support	1
2	Rear Stabilizer	1
3	Front Stabilizer	1
4	Front Post	1
5	Left Seat Bracket	1
6	Right Seat Bracket	1
7	Backrest Support	1
8	Incline Support	1
9	T-shaped Pull Pin	1
10	Axle	1
11	Lock Pin	1
12	Handle	1
13	M6 x 5/8" Allen Bolt	2
14	Ø 1 1/4" x 3/4" End Cap	1
15	Grip	1
16	Seat Pad	1
17	Backrest Board	1
18	Panel	1
19	Ø 5/8" x Ø 1" Bushing	2
20	2 3/8"x 1 1/8" End Cap	1
21	M10 x 4 3/4" Allen Bolt	1
22	M12 x 3" Allen Bolt	1
23	M10 x 5/8" Allen Bolt	6
24	M5 x 1/4" Allen Bolt	1
25	M6 x 3/4" Allen Bolt	4
26	M8 x 1 3/4" Allen Bolt	4
27	M8 x 5/8" Allen Bolt	3
28	M12 Aircraft Nut	1
29	M10 Aircraft Nut	3
30	Ø 1" Washer	2
31	Ø 3/4" Washer	10
32	Ø 5/8" Washer	13
33	Ø 1/2" Washer	4
34	#8 Allen Wrench (Tool)	1
35	#6 Allen Wrench (Tool)	1
36	#5 Allen Wrench (Tool)	1
37	#3 Allen Wrench (Tool)	1
38	Ø 1" x Ø 1/2" Bushing	2
39	Ø 1" x Ø 5/8" Bushing	2
40	Wheel	2
41	M8 Aircraft Nut	2

IMPEX[®] INC.

LIMITED WARRANTY

IMPEX Inc. ("IMPEX[®]") warrants this product to be free from defects in workmanship and material, under normal use and service conditions, for a period of two years on the Frame from the date of purchase. This warranty extends only to the original purchaser. IMPEX's obligation under this Warranty is limited to replacing or repairing, at IMPEX's option.

All returns must be pre-authorized by IMPEX. Pre-authorization may be obtained by calling IMPEX Customer Service Department at 1-800-999-8899. All freights on products returned to IMPEX must be prepaid by the customer. This warranty does not extend to any product or damage to a product caused by or attributable to freight damage, abuse, misuse, improper or abnormal usage or for products used for commercial or rental purposes. No other warranty beyond that specifically set forth above is authorized by IMPEX.

IMPEX is not responsible or liable for indirect, special or consequential damages arising out of or in connection with the use or performance of the product or other damages with respect to any economic loss, loss of property, loss of revenues or profits, loss of enjoyments or use, costs of removal, installation or other consequential damages or whatsoever natures. Some states do not allow the exclusion or limitation of incidental or consequential damages. Accordingly, the above limitation may not apply to you.

The warranty extended hereunder is in lieu of any and all other warranties and any implied warranties of merchantability or fitness for a particular purpose is limited in its scope and duration to the terms set forth herein. Some states do not allow limitations on how long an implied warranty lasts. Accordingly, the above limitation may not apply to you.

This warranty gives you specific legal right. You may also have other rights which vary from state to state.

IMPEX[®] INC.
14777 Don Julian
City of Industry, CA 91746

ORDERING REPLACEMENT PARTS

Replacement parts can be ordered by calling our Customer Service Department toll-free at 1-800-999-8899 during our regular business hours: Monday through Friday, 9 am until 5 pm Pacific standard time.

www.impex-fitness.com

info@impex-fitness.com

When ordering replacement parts, always give the following information.

1. **Model**
2. **Description of Parts**
3. **Part Number**
4. **Date of Purchase**