



Ride with a smile

SERVICE MANUAL

Cikada Touring EBike

(For European Version-EU2023DEC22V.01)

Table of Contents

General Information

Main Parts Indication.....	P2
Electronic System – Motor(with built-in Controller).....	P3~P6
Electronic System – Console.....	P7~P17

Troubleshooting

Error Codes.....	P18~P20
------------------	---------

Parts Dismounting/Installation Procedures

Front Wheel.....	P21	Rear Wheel.....	P21
Braking Disc.....	P22	Cassette/Freewheel.....	P22
Console/Meter.....	P23	Handlebar Grip.....	P24
Trigger Shifter.....	P24	Hand Brake Lever.....	P25
Kick Stand.....	P26	Pedals/Cranks.....	P26
Chain Ring and Chain.....	P27.P28	Motor.....	P28
Battery, Base and Key Set.....	P29.P30	Handlebar and Fork.....	P31
Front Light and Front Fender.....	P32	Rear Fender.....	P33
Saddle and Rack.....	P33	Tail Light.....	P34

Maintenance

General maintenance.....	P35
Motor maintenance.....	P36

General Information

Main Parts Indication

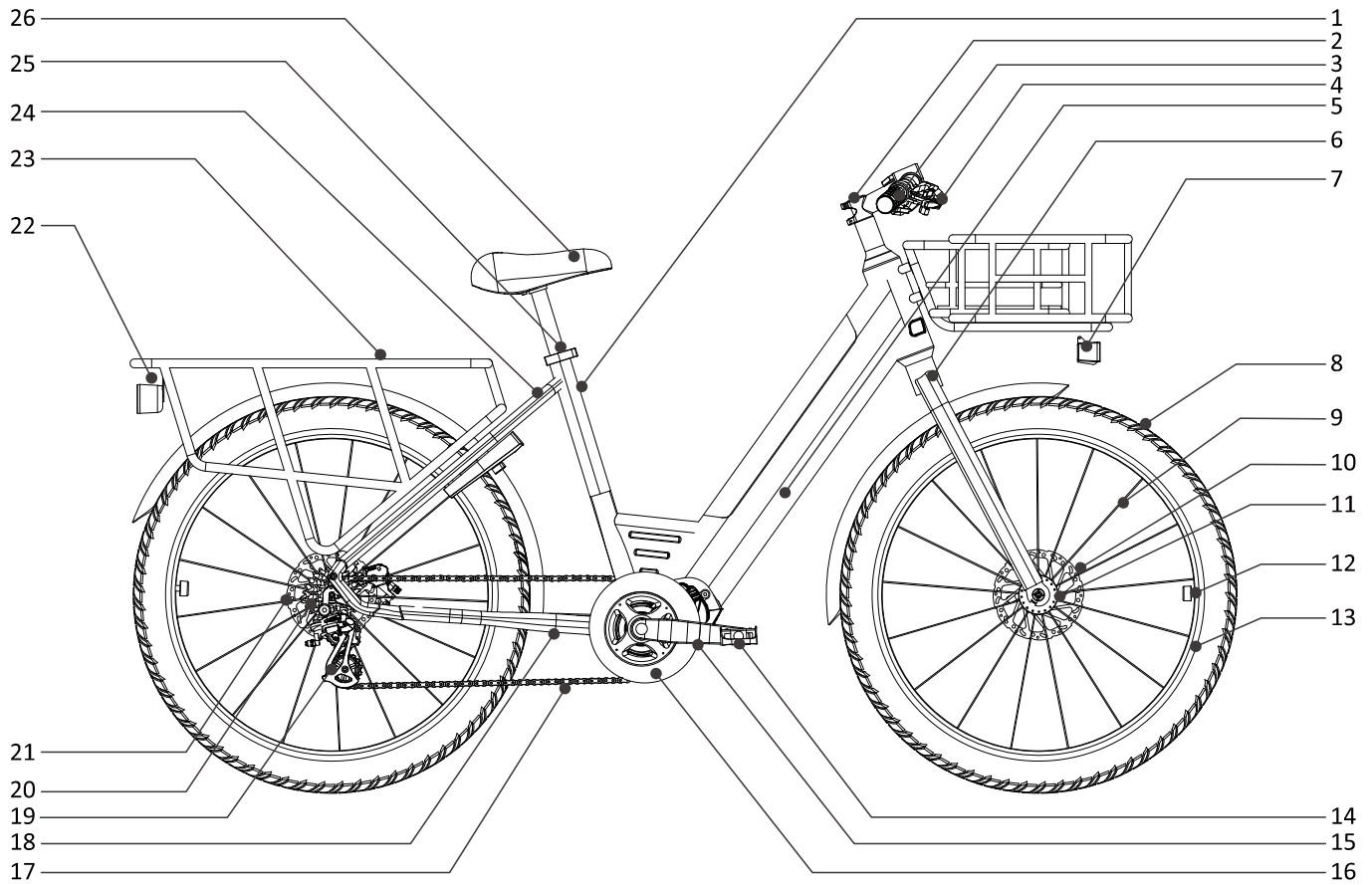

1	Seat tube	14	Pedal
2	Handle bar stem	15	Crank
3	Handlebar	16	Chain ring
4	Brake lever	17	Chain
5	Down tube	18	Chain stay
6	Front fork / suspension fork	19	Rear derailleur
7	Headlamp	20	Cassette
8	Tire	21	Rear brake
9	Spoke	22	Rear lamp/ Reflecor
10	Front brake	23	Luggage carrier
11	Wheel hub	24	Seat stay
12	Valve	25	Seat post clamp
13	Rim	26	Saddle

Electronic System – Motor (with built-in controller)

Appearance



Identification:

There are the unique identifications of the product on the housing, as shown in figure.

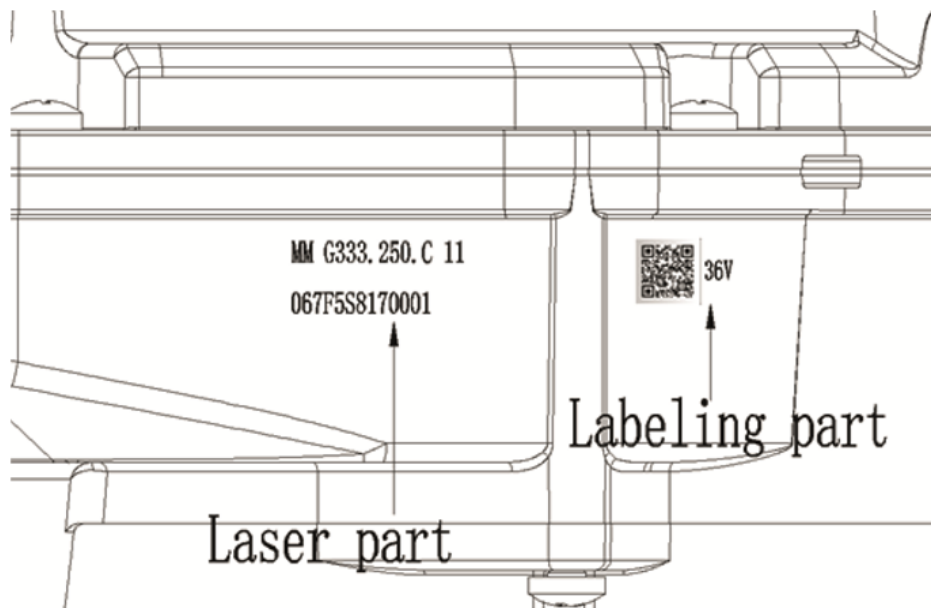

Note: Contents in Label part are important information of this product. Please keep them properly for updating of software or providing after-sales service.

Specifications

a) Spec. table

Rated power (W)	250
Rated voltage (V)	48 / 48 / 48
Waterproof	IP65
Outdoor Temperatures	-20°C ~45°C

b) Outline and geometric size

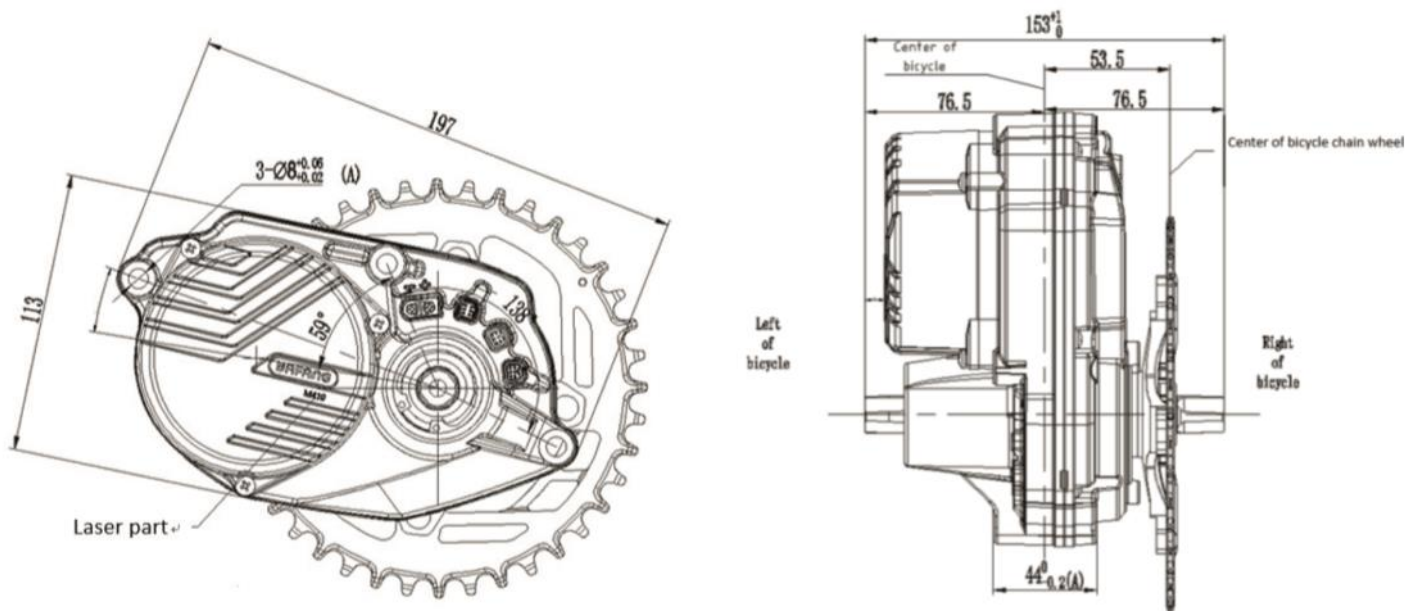

a) Surface & Storage

It comes with shockproof black coating on surface and should be stored in a ventilated humid/ dry room. Please avoid to store it near strong magnetic objects.

Cabling

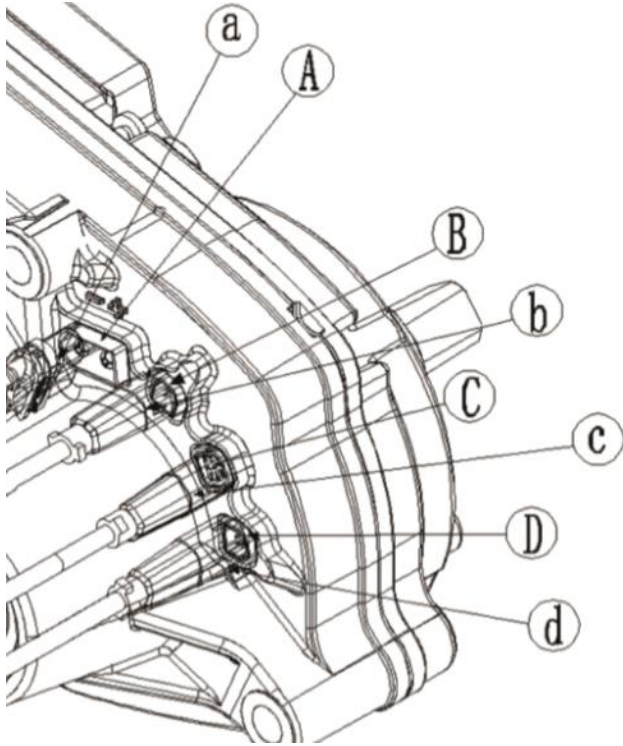

A = Male connector for power supply at the drive unit
a = Female connector for power supply at the battery

B = Male connector (6 pin) at the drive unit
b = Female connector (6 pin) for other device

C = Female connector (8 pin) at the drive unit
c = Male connector (8 pin) rear BUS cable

D = Male connector (8 pin) at the drive unit
d = Female connector (8 pin) at the front BUS cable

Installations

a) Bash guard and cover

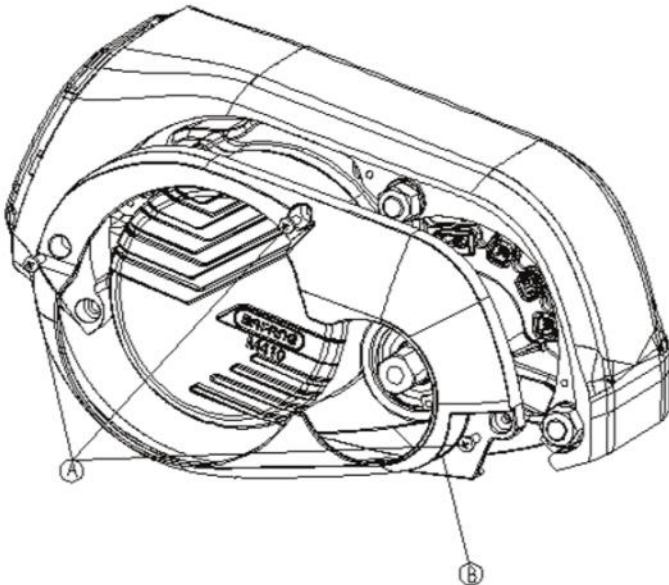

A = Hexalobular socket pan head screw M3*8

B = Cover

Use a T10 Torx screw driver to tighten 3 M3*8 screws through hole sites on the covering case to the frame interface, with tightening torque at 1 N.m.

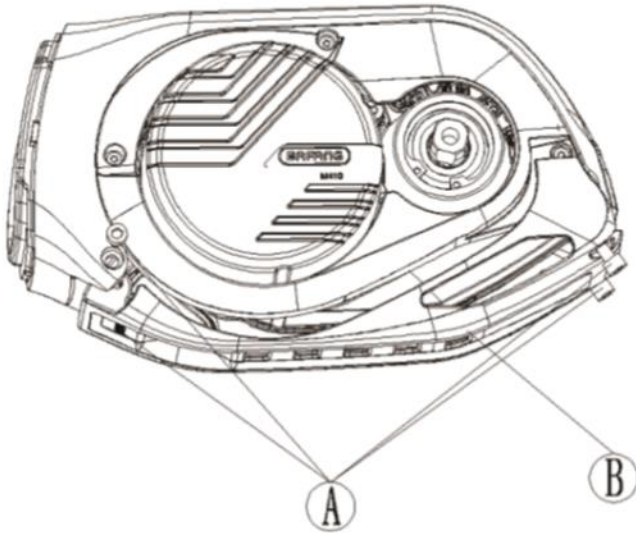

A = Hexagonal socket head cap screw M5*8

B = Bash guard

Use an internal hex wrench to tighten 4 M5*8 screws through hole sites on the bash guard to the frame interface, with tightening torque at 4 N.m.

b) Chain wheel

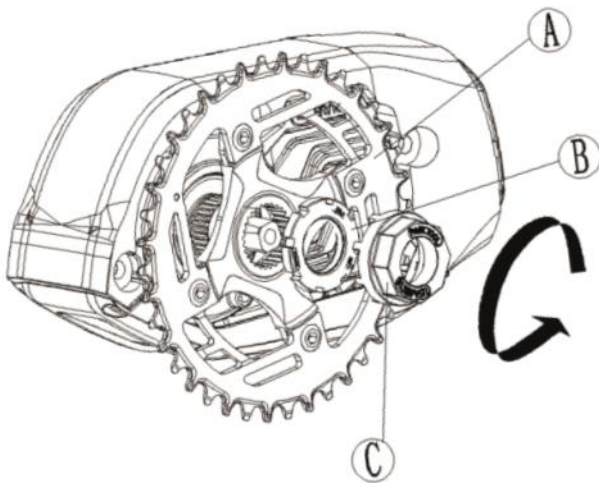

A = Chain wheel (Chain wheel shall be made according to orders of the customers)

B = Lock ring

C = S-tool(Special Tool from Supplier)

Step-1) Put the chain wheel onto the spline shaft of the drive unit.

Step-2) Use S-tool to fasten the lock ring onto the spline shaft, with tightening torque at 35 N.m.

c) Crank

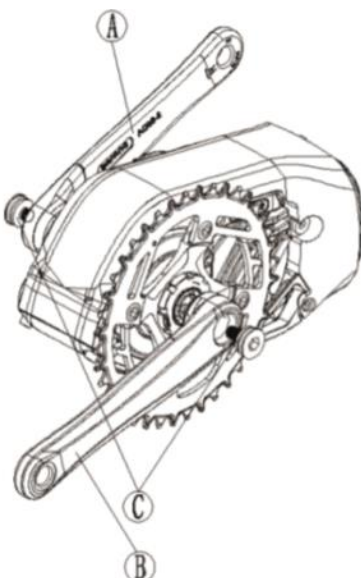

A = Left crank

B = Right crank

C = Hexagon socket screw M8*P1*15

Step-1) After mounting the right crank on the right shaft. Alternately fasten 2 M8*P1*15 screws with an internal hex wrench. (Note: Do not fasten them from one side at a time.) Torque is 1.5 N.m.

Step-2) Install the left crank in the same way. (Note: Please make sure two cranks are parallel.)

Electronic System – Console

Appearance



Important Notice

- If the error information from the display cannot be corrected according to the instructions, please contact your retailer.
- The product is designed to be waterproof. It is highly recommended to avoid submerging the display under water.
- Do not clean the display with a steam jet, high-pressure cleaner or water hose.
- Please use this product with care.
- Do not use thinners or other solvents to clean the display. Such substances can damage the surfaces.
- Warranty is not included due to wear and normal use and aging.

Introduction of Console

Specifications

- Operating temperature: -20°C~45°C
- Storage temperature: -20°C~50°C
- Waterproof: IPX5
- Storage room Humidity: 30%-70% RH

Functional Overview

- Speed display (including top speed and average speed, switching between km and miles)
- Battery capacity indicator
- Lighting control
- Brightness setting for backlight
- Walk assistance
- Indication of performance support
- Motor output power indicator
- Time display for single journeys
- Kilometer stand (including single-trip distance, total distance and remaining distance)
- Setting the support levels
- Energy consumption indicator CALORIES (Note: If the display has this function)
- Display for the remaining distance (Depends on your riding style)
- Information View (battery, controller, HMI and sensor)
- Error messages view
- Bluetooth function

Installation

1. Remove the holding bracket from the display, and then place the display into position on the handlebar. (suitable for OD 22.2mm handlebar).
2. Then place the holding bracket on the underside of the display and tighten it into position with a M3.0*8 screw. Torque requirement: 1.0 N.m.

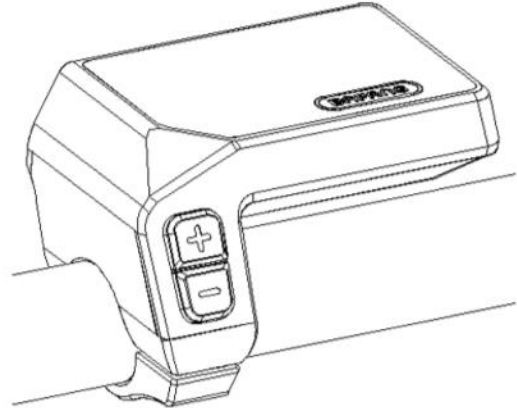

3. Connect the display connector to the EB-BUS connector, ensuring both connectors are kept parallel when pushing firmly together.

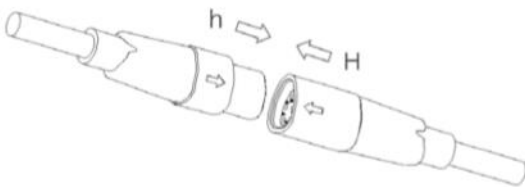

Displays



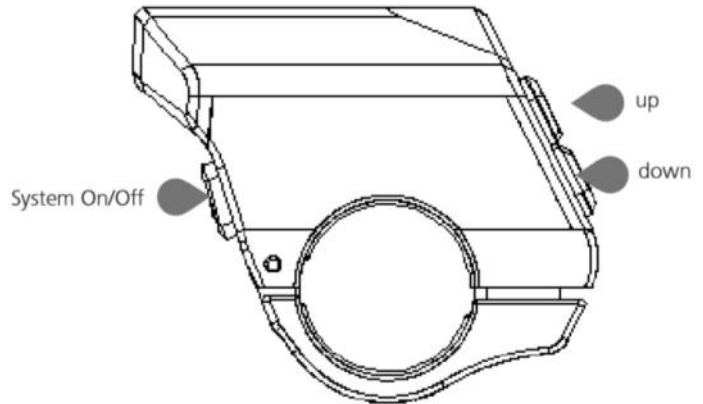
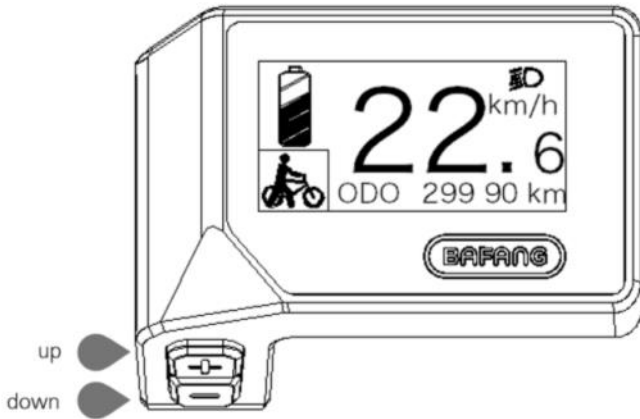

1. Display of battery capacity in real time.
2. Indicator of support level/walk assistance.
3. The display shows this symbol, When the lights are turned on.
4. Indicator of bluetooth
5. Unit of speed
6. Digital speed display
7. Trip: Daily kilometers (TRIP) - Total kilometers (ODO) - Top speed (MAX) - Average speed (AVG) - Remaining distance (RANGE) - Energy Consumption (CALORIES) - Output power (POWER)- Travel time (TIME).





Operation

Switching the System ON/OFF

Press and hold  (>2S) on the display to turn on the system. Press and hold  (>2S) again to turn off the system.

If the "automatic shutdown time" is set to 5 minutes (it can be reset with the "Auto Off" function, See "Auto Off"), the display will automatically be turned off within the desired time when it is not in operation. If the password function is enabled, you must enter the correct password to use the system.

Selection of Support Levels

When the display is turned on, press the  or  button (<0.5S) to switch to the support level, the lowest level is 0, the highest level is 3. When the system is switched on, the support level starts in level 1. There is no support at level 0.



Selection mode

Briefly press the  button (<0.5s) to see the different trip modes. Trip: daily kilometers (TRIP) - total kilometers (ODO) - Maximum speed (MAX) - Average speed (AVG) - Remaining distance (RANGE) - Energy consumption (CALORIES) - Output power (POWER) - Travel time (TIME).

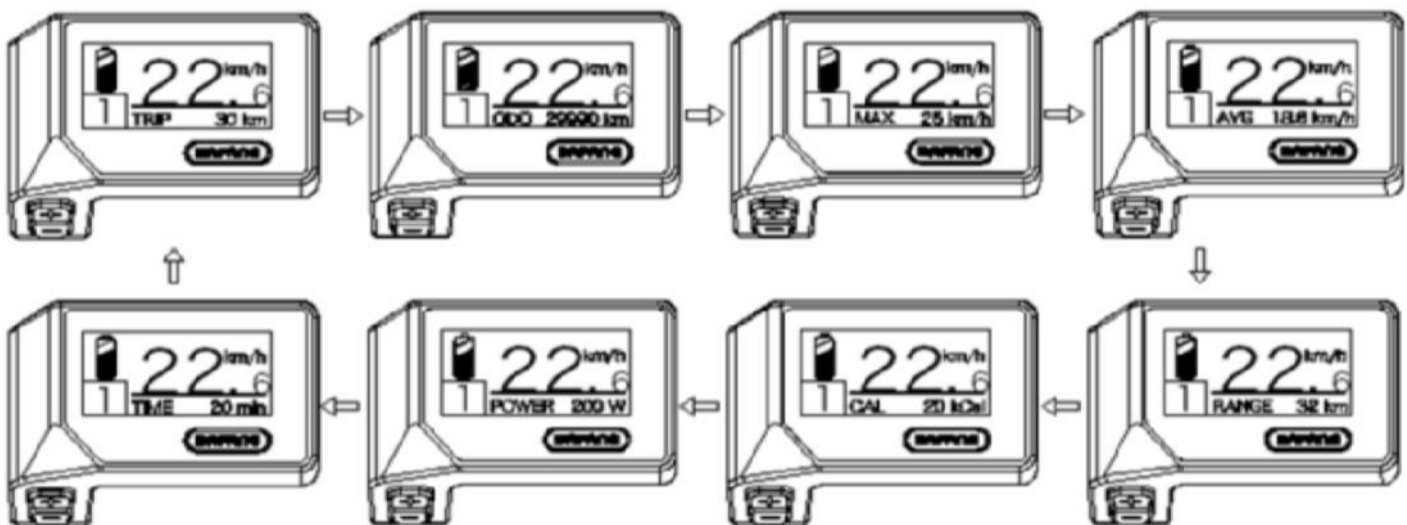

Headlights / backlighting

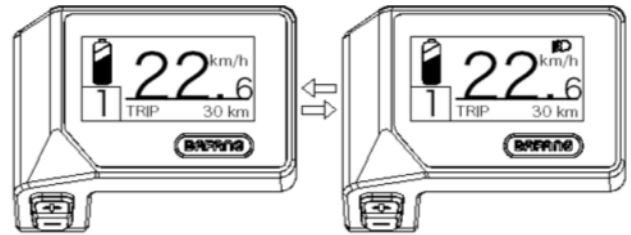

Hold the **+** button (>2S) to activate the headlight and taillights.

Hold the **+** button (>2S) again to turn off the headlight. The brightness of the backlight can be set in the display settings "Brightness".



Walk Assistance

The Walk assistance can only be activated with a standing pedelec.

Activation: Press the **+** button until this symbol  appears. Next press and hold down the **+** button whilst the  symbol is displayed, now the Walk assistance will activate. The symbol  will blink and the pedelec moves approx. 4.5 km/h. After releasing the **+** button or no button is pressed within 5S, the motor stops automatically and switches back to level 0.

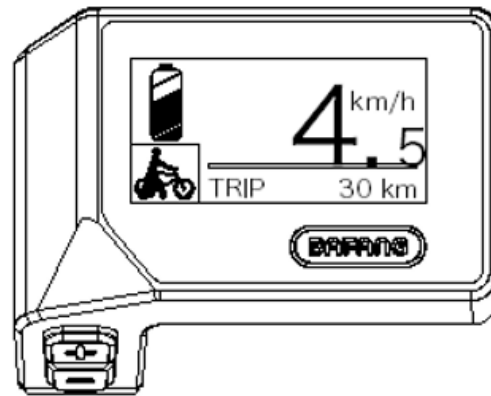







Service

The display shows "SERVICE" as soon as a certain number of kilometers or battery charges has been reached. With a mileage of more than 5000 km (or 100 charge cycles), the "SERVICE" function is displayed on the display. Every 5000 km the display "SERVICE" is displayed every time. This function can be set in the display settings "Brightness".









Battery capacity indicator

The battery capacity is shown in the top left of the display. Each full bar represents a remaining capacity of the battery in a percentage.



Capacity Range	Indicator
80%-100%	
60%-80%	
40%-60%	
20%-40%	
5%-20%	
<5%	 blinking

Settings

After the display is turned on, press and hold the  and  buttons (at the same time) to enter into the setting menu, By pressing the  or  button (<0.5S), you can highlight and select Display Setting, Information or Exit. Then press the  button (<0.5S) to confirm your selected option.





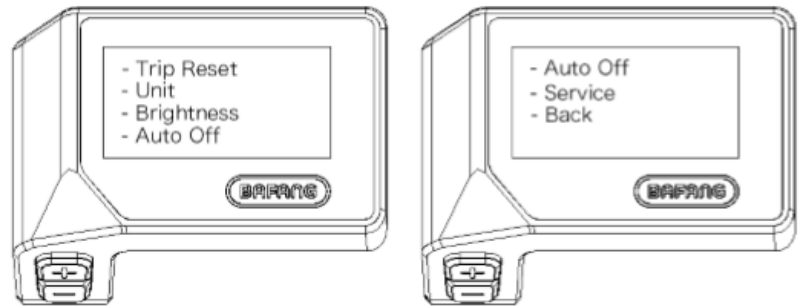

Or highlight "EXIT" and press the  button (<0.5S) to return to the main menu, or highlight "BACK" and press (<0.5S) the  button (<0.5S) to return to the Settings interface.

Display Setting

Press the  or  button (<0.5S) and highlight Display Setting, and then briefly press the  button (<0.5S) to access the following selections.



TRIP Reset / Reset mileage

Press the  or  button (<0.5S) to highlight "Trip Reset" in the Display setting menu, and then press  button (<0.5S) to select. Then with the  or  button choose between "YES" or "NO". Once you have chosen your desired selection, press the  button (<0.5S) to save and exit to the "Display setting".

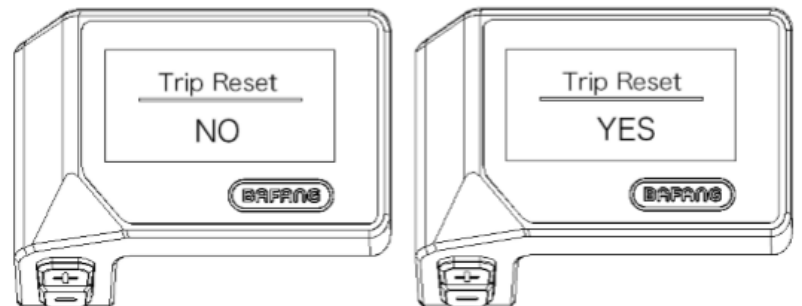

Unit Selections in km/Miles

Press the **+** or **-** button (<0.5S) to highlight "Unit" in the Display setting menu, and then press **⏻** button (<0.5S) to select. Then with the **+** or **-** button choose between "Metric" (kilometer) or "Imperial" (Miles). Once you have chosen your desired selection, press the **⏻** button (<0.5S) to save and exit to the "Display setting".

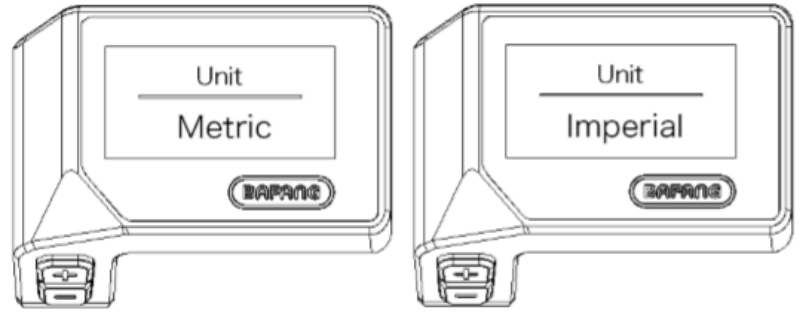

Brightness Display brightness

Press the **+** or **-** button (<0.5S) to highlight "Brightness" in the Display setting menu, and then press **⏻** button (<0.5S) to select. Then with the **+** or **-** button choose between "100%" / "75%" / "50%" / "30%" / "10%". Once you have chosen your desired selection, press the **⏻** button (<0.5S) to save and exit to the "Display setting".

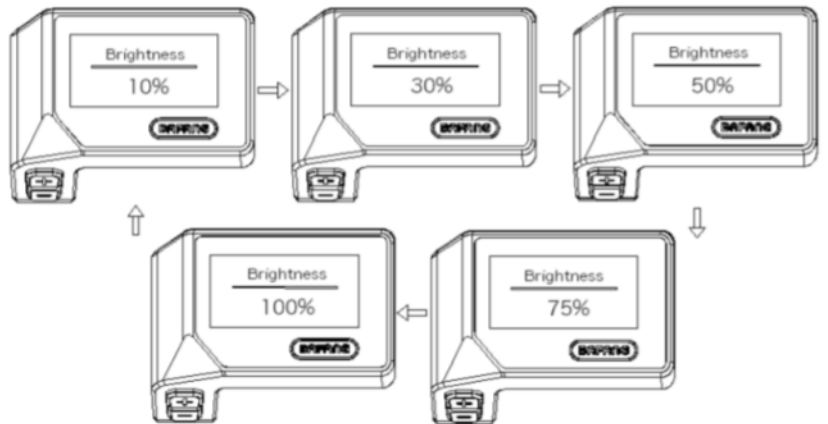

Auto Off Set Automatic system switch off time

Press the **+** or **-** button (<0.5S) to highlight "Auto Off" in the Display setting menu, and then press **⏻** button (<0.5S) to select. Then with the **+** or **-** button choose between "OFF", "9"/"8"/"7"/"6"/"5"/"4"/"3"/"2"/"1", (The numbers are measured in minutes). Once you have chosen your desired selection, press the **⏻** button (<0.5S) to save and exit to the "Display setting".

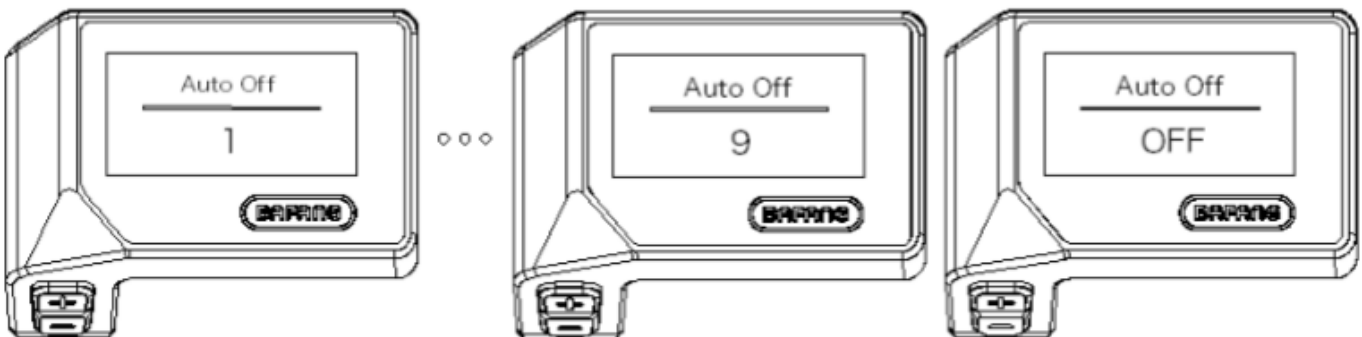

Service Switching the notification on/off

Press the **+** or **-** button (<0.5S) to highlight "Service" in the Display setting menu, and then press **Enter** button (<0.5S) to select. Then with the **+** or **-** button choose between "NO" or "YES". Once you have chosen your desired selection, press the **Enter** button (<0.5S) to save and exit to the "Display setting".

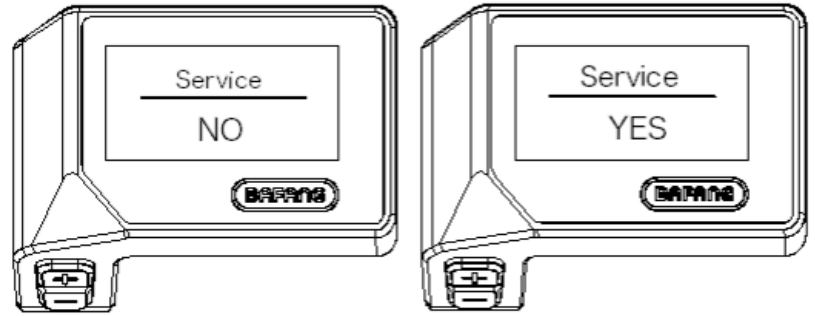

Information

Once the display is turned on, press and hold the **+** and **-** buttons (at the same time) to enter into the setting menu, press the **+** or **-** button (<0.5S) to select "Information", then press the **Enter** button (<0.5S) to confirm and enter into "Information".

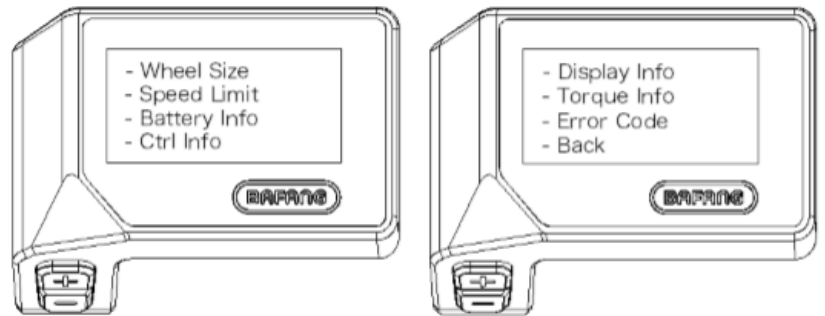

Wheel Size

Press the **+** or **-** button (<0.5S) to highlight "Wheel Size", then press the **Enter** button (<0.5S) to confirm and view the wheel size.

To return, press the **Enter** button (<0.5S) to exit back to the "Information".

This information cannot be changed, this is only for information, about the pedelec.



Speed Limit

Press the **+** or **-** button (<0.5S) to highlight "Speed Limit", then press the **Enter** button (<0.5S) to confirm and view the speed limit. To return, press the **Enter** button (<0.5S) to exit back to the "Information".

This information cannot be changed, this is only for information, about the pedelec.

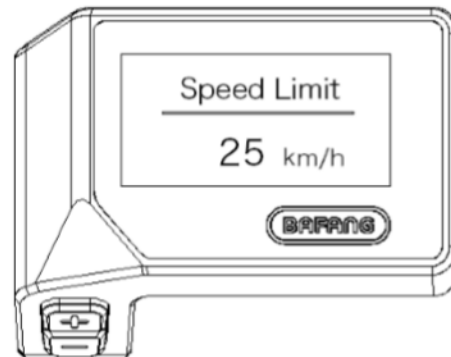

Battery Information

Press the **+** or **-** button (<0.5S) to highlight "Battery Info", then press the **⏻** button (<0.5S) to confirm. Now press the **+** or **-** button (<0.5S) to view the contents.

To return, press the **⏻** button (<0.5S) to exit back to the "Information".

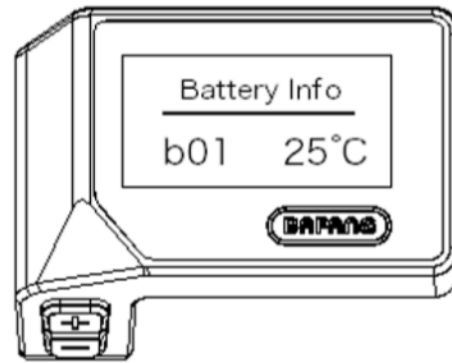

Code	Code definition	unit	Code	Code definition	unit
Hardware ver	Hardware version		b10	Absolute SOC	%
Software ver	Software version		b11	Cycle	times
b01	Current temperature	°C	b12	Maximum not charging time	Hour
b04	Total voltage	mV	b13	Recently not charging time	Hour
b06	Average current	mA	d00	Number of battery cell	
b07	Remaining capacity	mAh	d01	Voltage of cell 1	mV
b08	Full charge capacity	mAh	d02	Voltage of cell 2	mV
b09	Relative SOC	%	dn	Voltage of cell n	mV

Note: If no data is detected, "—" is displayed.

Controller Information

Press the **+** or **-** button (<0.5S) to highlight "Ctrl Info", then press the **⏻** button (<0.5S) to confirm. Now press the **+** or **-** button (<0.5S) to view Hardware Version or Software Version.

To return, press the **⏻** button (<0.5S) to exit back to the "Information".

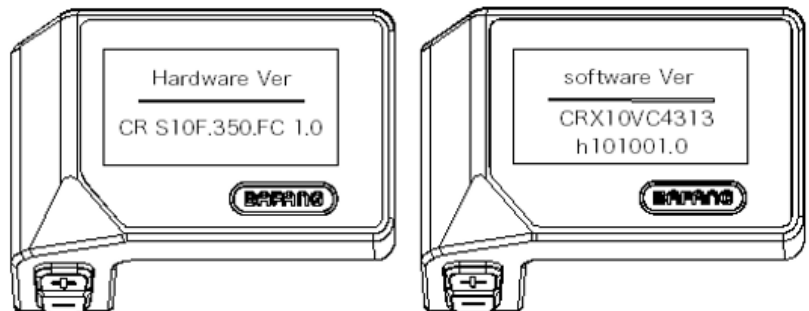

Display Information

Press the **+** or **-** button (<0.5S) to highlight "Display Info", then press the **⏻** button (<0.5S) to confirm. Now press the **+** or **-** button (<0.5S) to view Hardware Version or Software Version.

To return, press the **⏻** button (<0.5S) to exit back to the "Information".

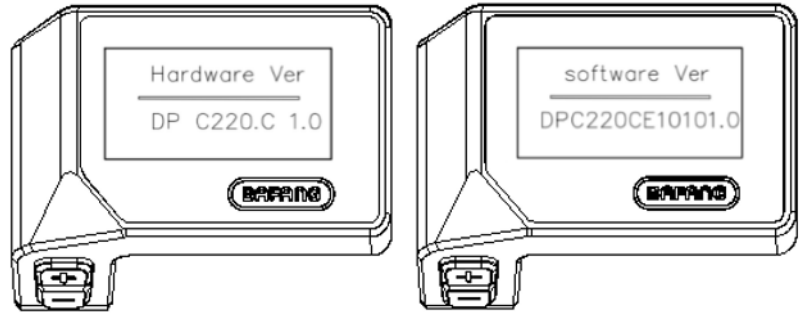

Torque Information

Press the **+** or **-** button (<0.5S) to highlight "Torque Info", then press the **⏻** button (<0.5S) to confirm. Now press the **+** or **-** button (<0.5S) to view Hardware Version or Software Version.

To return, press the **⏻** button (<0.5S) to exit back to the "Information".

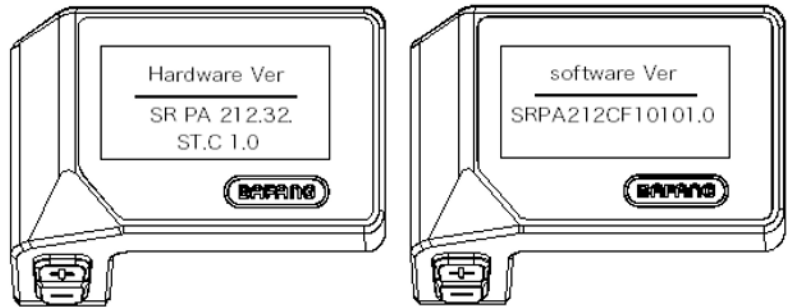

Error Code

Press the **+** or **-** button (<0.5S) to highlight "Error code", then press the **⏻** button (<0.5S) to confirm. Now press the **+** or **-** button (<0.5S) to view a list of error codes from the pedelec. It can show information for the last ten errors of the pedelec. The error code "00" means that there is no error.

To return, press the **⏻** button (<0.5S) to exit back to the "Information".

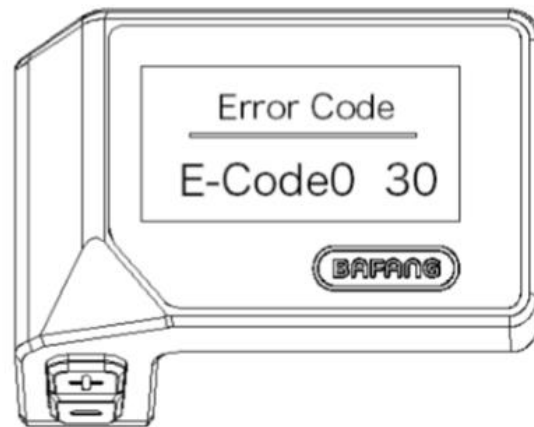

Troubleshooting

Error Codes

Error	Description	Trouble shooting
04	Faulty throttle	<ol style="list-style-type: none">1. Check the throttle connector and cable to see if they are damaged and connected incorrectly.2. Disconnect and reconnect the throttle, if still not operating please contact dealer.
05	Throttle is not back in correct position.	Check the connector from the throttle is correctly connected. If this does not solve the problem, please contact dealer.
07	Overvoltage protection	<ol style="list-style-type: none">1. Remove and re-Insert the battery to see if it resolves the problem.2. Using the BESST tool update the controller.3. Change the battery to resolve the problem
08	Faulty hall sensor signal inside motor	<ol style="list-style-type: none">1. Check all connectors from the motor are correctly connected.2. If the problem still occurs, please change the motor.
09	Motor malfunction	Please contact dealer.
10	Motor overheat protection	Turn off system and allow the motor to cool down. If problem still occurs, please contact dealer.
11	Motor temperature sensor error	Please contact dealer
12	Controller sensor error	Please contact dealer
13	Battery temperature sensor error	Please contact dealer
14	Controller overheat protection	Turn off system and allow controller to cool down. If problem still occurs, please contact dealer.
15	Controller temperature sensor error	Turn off system and allow controller to cool down.

		If problem still occurs, please contact dealer.
21	Speed sensor error	<ol style="list-style-type: none"> 1. Restart the system 2. Check if the magnet attached to the spoke is aligned with the speed sensor and that the distance is between 10 mm and 20 mm. 3. Check if the speed sensor connector is connected correctly. 4. Please contact dealer if error still occurs.
25	Torque signal error	<ol style="list-style-type: none"> 1. Make sure all connections are connected correctly. 2. Please contact dealer if problem still occurs.
26	Speed signal in torque sensor error	<ol style="list-style-type: none"> 1. Make sure all connections are connected correctly. 2. Please contact dealer if problem still occurs.
27	Controller overcurrent	Please contact dealer
30	Communication error	<ol style="list-style-type: none"> 1. Make sure all connections are connected correctly. 2. Please contact dealer if problem still occurs.
33	Brake signal error	<ol style="list-style-type: none"> 1. Make sure all connections are connected correctly. 2. Please contact dealer if problem still occurs.
35	15V detection circuit error	Please contact dealer
36	Keypad detection circuit error	Please contact dealer
37	WDT circuit error	Please contact dealer
41	Total voltage too high	Please contact dealer
42	Total voltage too low	Please contact dealer
43	Total battery power too high	Please contact dealer
44	Single cell battery high voltage	Please contact dealer

45	High battery temperature	Turn off system and allow battery to cool down. If problem still occurs, please contact dealer.
46	Low battery temperature	Bring battery to room temperature Please contact dealer if problem still occurs.
47	Battery SOC too high	Please contact dealer
48	Battery SOC too low	Please contact dealer
71	Electronic lock error	Please contact dealer
81	Bluetooth module error	Please contact dealer

Parts Dismounting (Installation) Procedures

Take off the Front Wheel

Tool: Manual



1/3) Reach the lever/nut of axle from front wheel.



2/3) Hold the nut and pull up the lever (turn it by counterclockwise) to release the axle.



3/3) Pull out the axle and lift the frame to take off front wheel from frame.

Note: For installation, please reverse these procedures to install it back. Suggested to tighten up the nut by 5~7.5N.M torque.

Take off the Rear Wheel

Tool: Manual



1/4) Reach the lever/nut of axle from rear wheel.

2/4) Hold the nut and pull up the lever (turn it by counterclockwise) to release the axle.

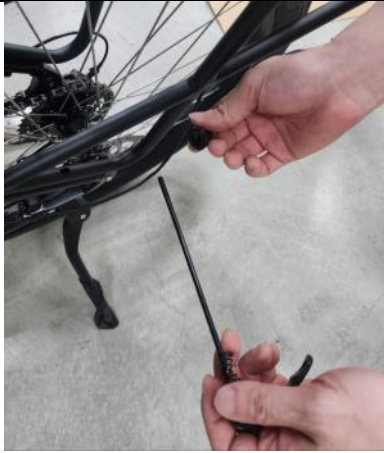

3/4) Pull out the axle from wheel.



4/4) Take off rear wheel from frame.

Note: For installation, please reverse these procedures to install it back. Suggested to tighten up the nut by 5~7.5N.M torque

Take off the Braking Disc

Tool: T25 Torx Hex Key



1/1) Use T25 Torx hex key to release attached 6 bolts. Then Braking Disc can be taken off.

Note: For installation, please reverse these procedures to install it back. Suggested to tighten up each screw by 2~4N.M torque

Take off Cassette/Freewheel

Tool: Manual & Freewheel Remover (Super B TB-CP15) and chain whip



1/3) Hold the cassette/freewheel by chain whip and use the remover to release locking cap.



2/3) Take off the locking cap.



3/3) Take off the cassette/freewheel from hub.

Note: For installation, please reverse these procedures to install it back. Suggested to tighten up the locking cap by 40N.M torque

Take off the Console/Meter

Tool: M2.5 Hex key



1/3) Unplug the connectors of console cable.



2/3) Use M2.5 hex key to take of bolt.



3/3) Take off console from handlebar.

Note: For installation, please reverse these procedures to install it back. Suggested to tighten up the bolt by 1N.M torque

Take off Handlebar Grip

Tool: Manual



1/1) For grip without accelerator attached, please pull out the grip from handlebar directly to take off grip.

Note: For installation, please reverse these procedures to install it back.

Take off Trigger Shifter

Tool: M4 & M5 Hex key



1/5) Take off the grip.



2/5) Use M5 hex key to release the cable (around the rear wheel as photo shown). **Suggested to tighten up the bolt by 5~7N.M torque when installation.**



3/5) Separate cable hose from Trigger Shifter.



4/5) Release the bolt by M4 hex key. **Suggested to tighten up the bolt by 3N.M torque when installation.**



5/5) Take off the trigger shifter set from handlebar and draw out the steel cable from hose.

Note: For installation, please reverse these procedures to install it back.

Take off Hand Brake Lever

Tool: M4 Hex key, 8mm wrench



1/3) Pull out the cap to reach nut and use 8mm wrench to take off the braking cable. **Suggested to tighten up the connector by 5~7N.M torque when installation.**



2/3) Unplug the signal cable.



3/3) Use M4 hex key to release attached bolts then take of the hand brake lever set.

Note: For installation, please reverse these procedures to install it back. Suggested to tighten up the bolt by 4~6N.M torque.

Take off the Kick Stand

Tool: M5 Hex key



1/1) Use M5 hex key to release attached bolts then take off the kick stand set.

Note: For installation, please reverse these procedures to install it back.

Take off Pedals/Cranks

Tool: M8 Hex key, 15mm Wrench and Crank puller



Watch Out!

Left Side Pedal

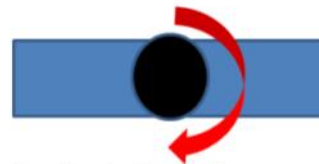

By clockwise to loosen the left pedal

Right Side Pedal

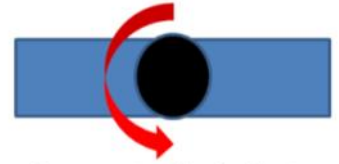

By counterclockwise to loosen the right pedal



1/6) Use 15mm wrench to release pedal from crank. **Suggested to tighten up the pedal by 35~55N.M torque when installation.**

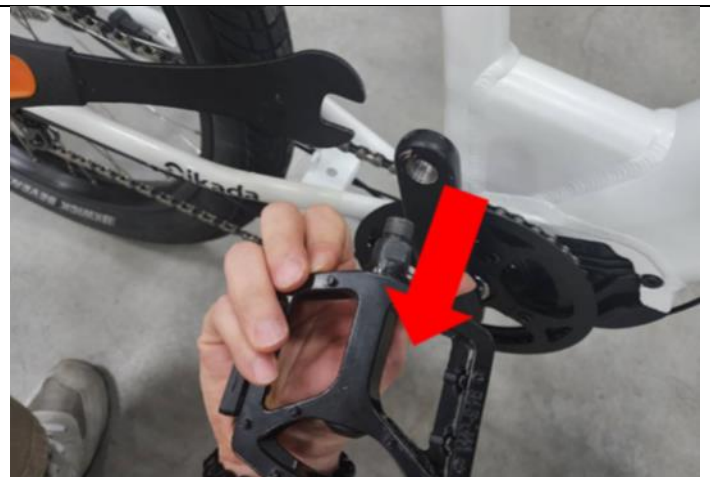

2/6) Take off the pedal from crank.



3/6) Use M8 hex key to release the crank bolt (by counterclockwise to loosen it). **Suggested to tighten up the crank bolt by 38~42N.M torque when installation.**



4/6) Take off the crank bolt from crank.

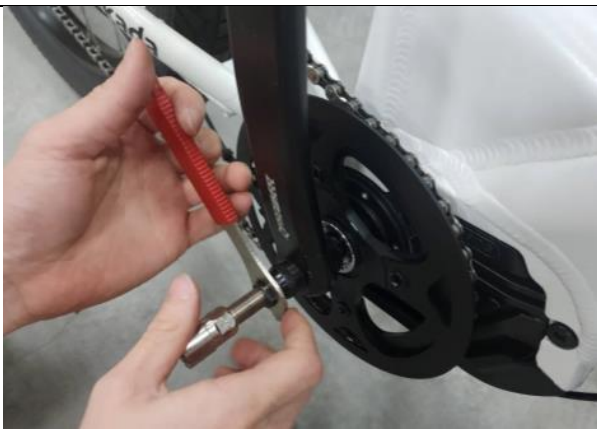

5/6) Use crank puller to pull out the crank from axle.



6/6) Take off the crank from axle.

Note: For installation, please reverse these procedures to install it back.

Take off Chain Ring

Tool: B.B. Tool (Superb TB-BB30) and chain whip



1/1) Hold the chain ring by chain whip and use BB tool to take off the chain ring.

Note: For installation, please reverse these procedures to install it back. Suggested to tighten up the bolt by 35N.M torque.

Take off Chain

Tool: Chain Rivet Extractor



1/1) Use chain rivet extractor to push out the rivet then take off the “break” chain from gears.

Take off Motor

Tool: Diagonal Cutting Pliers, 13mm Socket & Ratchet Wrench, M5 Hex Key.



1/5) Make the bike upside down to reach the motor bottom easily. Then cut off cable ties by pliers.



2/5) Use M5 hex key to take off attached 4 bolts. **Suggested to tighten up the bolt by 4N.M torque when installation.**



3/5) Move the cover aside and use 13mm socket/ratchet wrench with M5 hex key to take off attached 3 bolts from motor. **Suggested to tighten up the bolt by 35N.M torque when installation.**



4/5) Lift up the motor to reach plugged cables.



5/5) Unplug cables to take off motor.

Note: For installation, please reverse these procedures to install it back.

Take off Battery from frame

Tool: Key and Manual



1/3) Turn the battery locking key and take off the battery from frame.



2/3) If the battery is difficult to be installed into the battery base of frame. Then, please adjust the screws/metal plate under the battery as next step (3/3) mentioned..

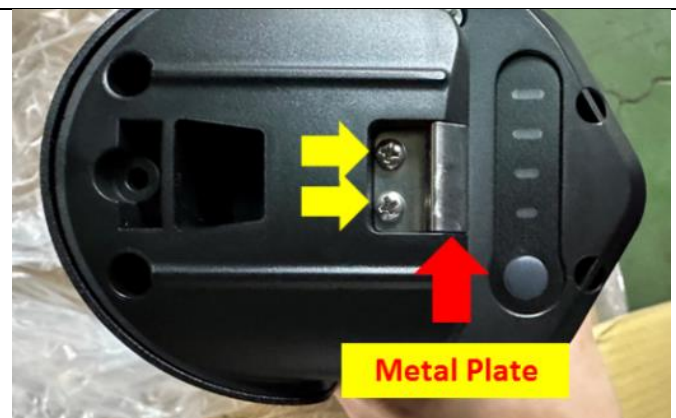

3/3) Loosen attached two screws and adjust the metal plate to allow more space for engaging the base then tighten up the screws.

Note: For installation, please reverse these procedures to install it back.

Take off Battery Upper Base and Key Set

Tool: Ph#1 Screwdriver



1/3) Take of the battery from frame.

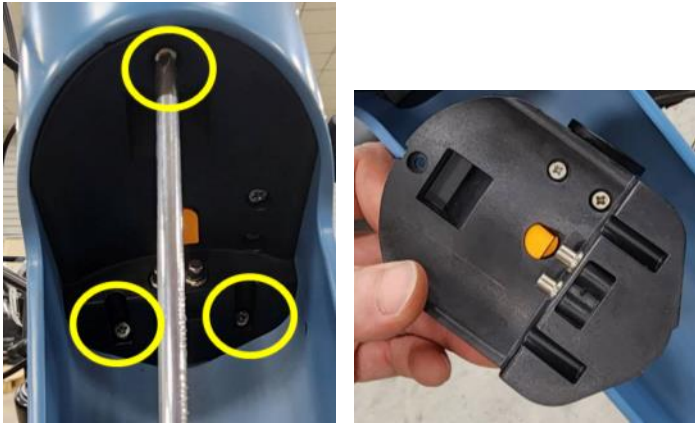

2/3) Use Philips screwdriver to take off attached 3 screws from upper base and take off the upper base from frame.



3/3) Use Philips screwdriver to take off attached 2 screws from upper base and take off the key set from upper base.

Note: For installation, please reverse these procedures to install it back.

Take off Battery Bottom Base

Tool: Ph#1 Screwdriver



1/3) Lift up the motor to reach cables.

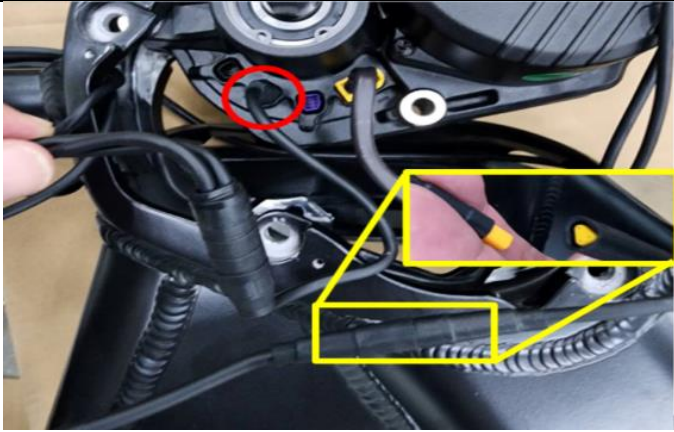

2/3) Pull out the cables from tube and find out red circled one. Unplug the yellow highlighted cable(it is one of 3 cables from red circled cable).



3/3) Use Philips screwdriver to take off attached 3 screws to dismount the bottom base.

Note: For installation, please reverse these procedures to install it back.

Take off the Handlebar and Fork

Tool: M4 Hex key

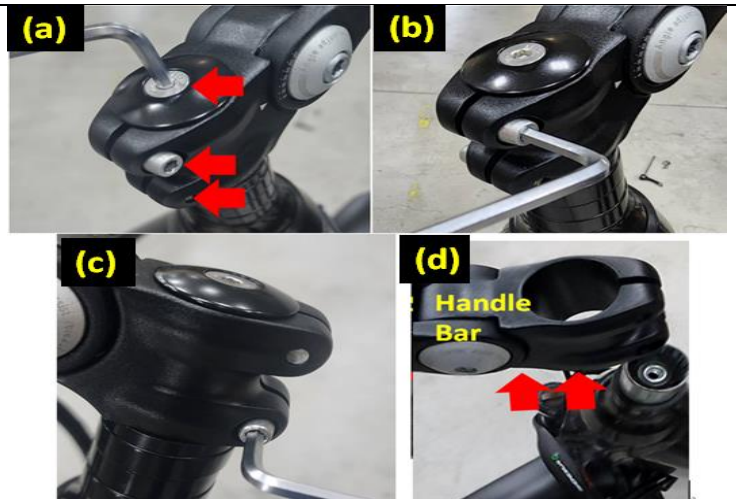

1/3) Use M4 hex key to take off attached 3 bolts and handlebar. **Suggested to tighten up the bolt by 8N.M torque for (a) and maximum 10N.M. for (c) when installation.**



2/3) Remove cap and spacers (as photo shown).



3/3) Take off fork.

Note: For installation, please reverse these procedures to install it back.

Take off Front Light and Front Fender

Tool: Ph#2 Screwdriver, 7mm wrench, M3 and M5 Hex Key.

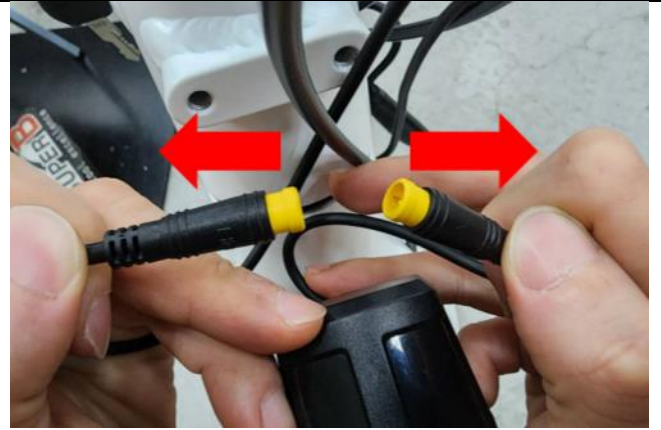

1/5) Unplug the front light cable.



2/5) Use M3 hex key and 7mm wrench to take off attached bolt.



3/5) Take off front light.



4/5) Use Philips screwdriver to take off 2 screws from fender.



5/5) Use M5 hex key to take off attached bolt from fork then take off front fender.

Note: For installation, please reverse these procedures to install it back.

Take off Rear Fender

Tool: M5 Hex Key.



1/1) Release tire pressure then use M5 hex key to take off attached bolts and take off front fender.

Note: For installation, please reverse these procedures to install it back.

Take off Saddle

Tool: M6 Hex Key



1/1) Use M6 hex key to take off attached bolt brackets for dismount the saddle.

Note: For installation, please reverse these procedures to install it back.

Take off Rack

Tool: Ph#2 Screwdriver, Diagonal Cutting Pliers.



1/3) Use diagonal cutting pliers to remove cable ties.



2/3) Use Philips screwdriver to take off attached screws. **Suggested to tighten up the bolt by 4N.M torque when installation.**



3/3) Take off rack from frame.

Note: For installation, please reverse these procedures to install it back.

Take off Tail Light

Tool: 8mm wrench

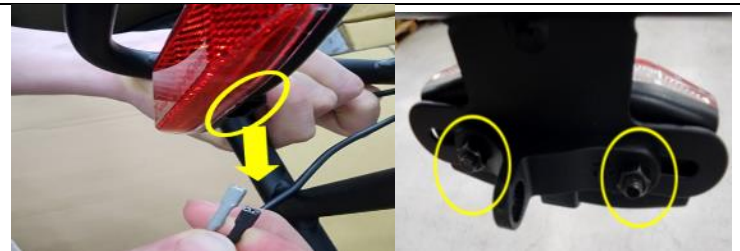

1/1) Unplug the light wires and use 8mm wrench to take off attached 2 bolts for dismounting the tail light.

Note: For installation, please reverse these procedures to install it back.

Maintenance

General maintenance

Inspection of handlebar and front & rear wheel:

- Move the Cikada Bike up, down, front, back, left and right to check whether the handlebars and the axle nuts of the front and rear wheels are tightened properly, whether the handlebars are tightened properly, and whether there is any abnormal rubbing or damage happening between parts.
- Push the vehicle back and forth to check whether the front and rear wheels rotate smoothly and without any abnormal noise or rubbing.
- Carefully check the entire vehicle before riding and if you find any issues, please contact a professional for repair or contact Cikada support for help.

Inspection of power circuit and lighting circuit:

- Turn on the power, operate the lighting switch, check whether the headlights and taillights are on, and if they are at normal levels.
- Check for any damage with the lighting system.
- Check whether the power cables on the Cikada Bike are connected and are operating safely as intended as well as whether all connectors are functioning properly. Inspection of front and rear brakes
- Adjustment of the brake lever: Pinch the front and rear brake levers and confirm whether the brakes are working when the distance between the brake lever and the handlebar is 1 inch.
- Adjustment method of the front and rear brakes: The distance between the brake and the brake lever is specified to be between 10-20mm.
- When the brake is in a tightly gripped state, the brake pad and the brake disc should be contacting evenly.
- The brake pads and brake discs should be replaced at the same time (the adjustment of the rear wheel brake is the same as that of the front wheel brake).

Battery installation status:

- Confirm that the battery is in a fixed state, connected, and operating properly.

Motor maintenance

- Maintenance must be carried out by authorized personnel with the correct equipment.
- Do not disassemble the motor.
- Do not use thinners or other solvents to clean the components. Such substances can damage the surfaces.
- Avoid water submerging, to keep the components protected.
- Avoid using high-pressure cleaning jets.
- For prolonged storage, turn off the battery and avoid storing near heat sources.