

GARAGE SMART

MY LIFTER

HARD TOP LIFTER

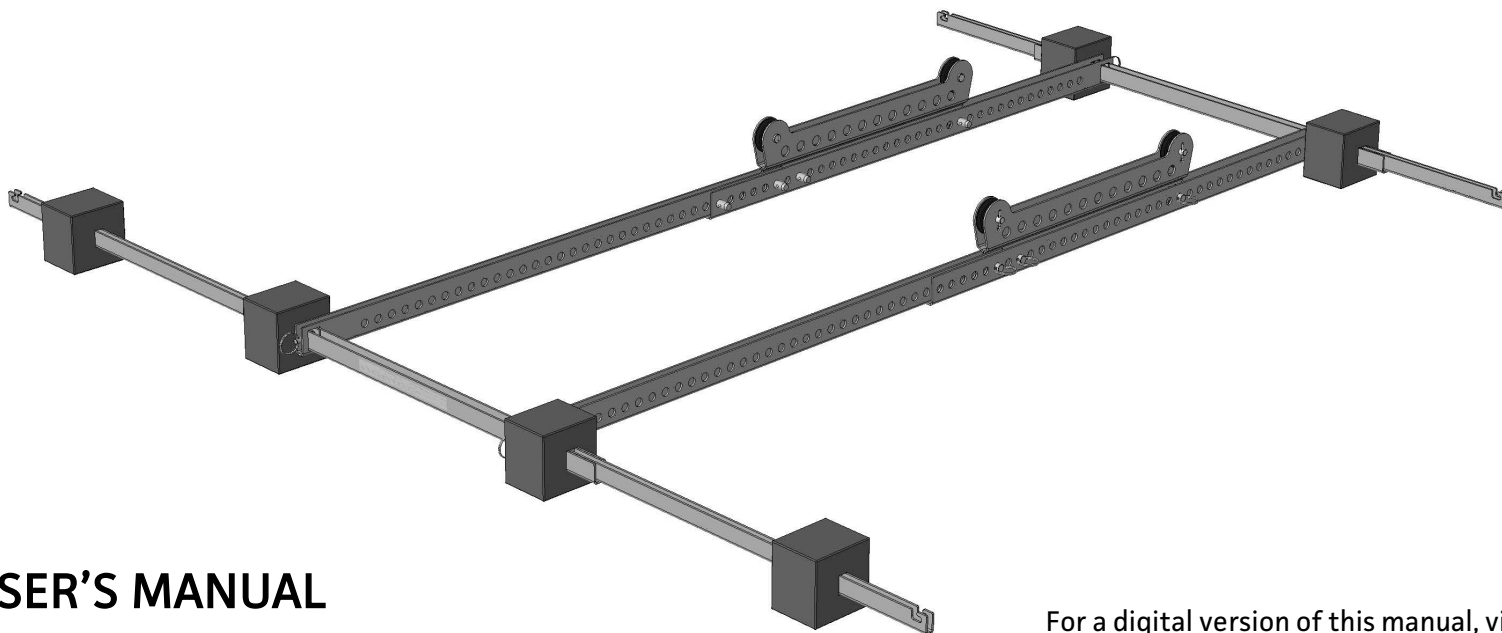

USER'S MANUAL

Save this manual for future reference

For a digital version of this manual, visit
www.garagesmart.com/manuals



TABLE OF CONTENTS

SAFETY INFORMATION/ABOUT HARDTOP LIFTER	2
PRODUCT IDENTIFIER	3
WHAT'S IN THE BOX?	4
HARDTOP LIFTER INSTALLATION – TOOLS AND NOTES	5
STEP 1: SMARTTRACK	6
SMARTTRACK TROUBLESHOOTING	7
STEP 2: ASSEMBLY - LENGTH ADJUSTER	8
STEPS 3 & 4: ASSEMBLY - WIDTH ADJUSTER and FOAM BLOCKS	9
STEP 5: ASSEMBLY - PULLEY SLIDER	10
STEP 6: ASSEMBLY – VEHICLE INSTALLATION	11
STEP 7: ASSEMBLY – CARGO NET AND CONFIGURATION	12
STEP 8: ASSEMBLY – ADJUSTMENTS	14
FAQs	16

SAFETY INFORMATION



WARNING

Failure to follow these safety instructions may result in property damage, serious personal injury, or death.

- 1 Read and follow all safety, installation, and operation instructions.
- 2 Do not lift with HardTopLifter while hands or other body parts are near the system.
- 3 Do not stand under the HardTopLifter.
- 4 Do not use HardTopLifter to lift people or animals.
- 5 Do not use HardTopLifter to lift or lower items over people or animals.
- 6 Total lifting capacity for HardTopLifter is 175 lbs.
- 7 Always balance load before lifting.

ABOUT HARDTOP LIFTER

The HardTopLifter is designed for home and garage use; it is not to be used in commercial or industrial applications.

The HardTopLifter is designed and intended to lift vehicle hard tops off the vehicle and to the ceiling.

PRODUCT IDENTIFIER

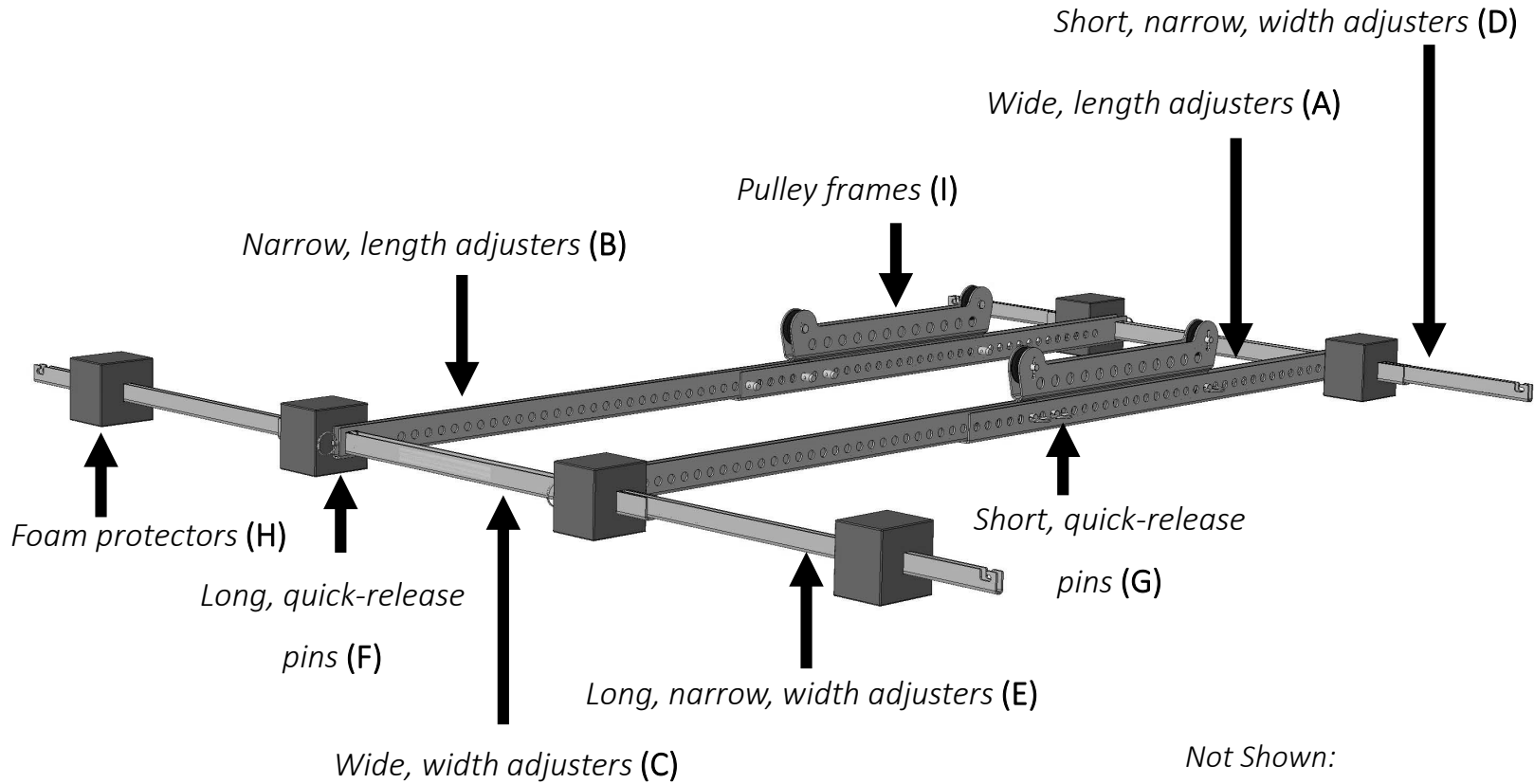

*Not Shown:
Track Cover, Half Size (J)
Cargo net (K)*

WHAT'S IN THE BOX?



Wide, length adjusters (A) 2x



Narrow, length adjusters (B) 2x



Wide, width adjusters (C) 2x



Short, narrow, width adjusters (D) 2x



Long, narrow, width adjusters (E) 2x

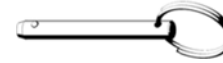

Long, quick-release pins (F) 2x



Short, quick-release pins (G) 8x

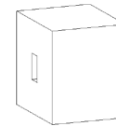

Foam protectors (H) 6x



Pulley frames (I) 2x



Track Cover, half-size (J) 1x

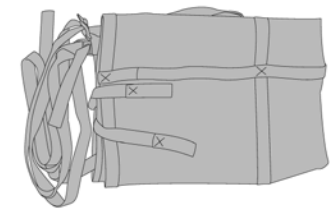

Cargo net (K) 1x

HARDTOP LIFTER INSTALLATION

TOOLS AND NOTES

NOTE

The frame should be assembled on the floor, lifted to the ceiling, and then set down on the roof of the vehicle.

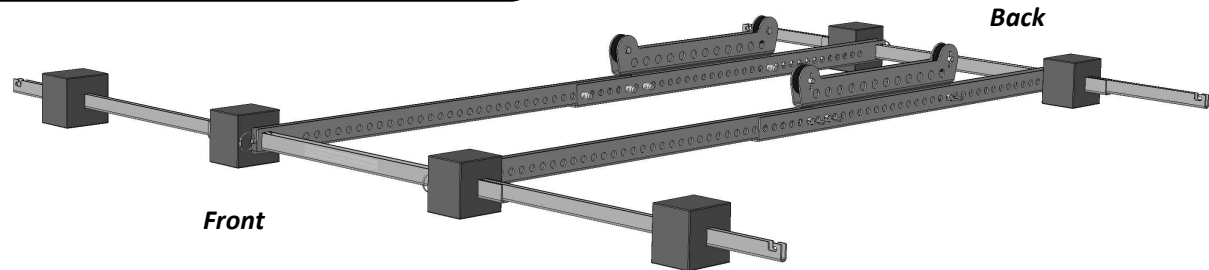

REQUIRED TOOLS AND COMPONENTS (not provided)

- MyLifter (x2)
- Track System (X2)
- Drill (*not shown*)
- ½" Socket and Wrench (*not shown*)
- Stud Finder (*not shown*)

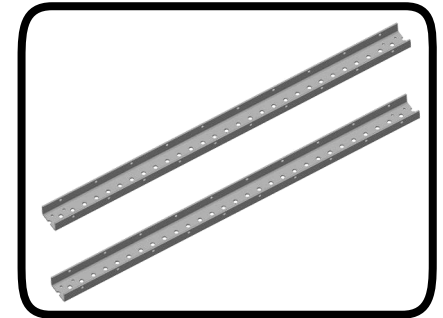

HARDTOP LIFTER INSTALLATION

1. SmartTrack Installation

1. Decide where to place your Hard Top Lifter by parking your vehicle in that location and assuring that there is enough space around the vehicle to move and to open doors slightly.
2. Install SmartTracks so each is across two ceiling joists. Place them 15" apart on center above the vehicle's intended location. (*Fig 1.1*)
3. Mount myLifters on tracks 15" apart. They can be mounted on the same rail (*Fig 1.2a*), or on opposite rails (*Fig 1.2b*), depending on the direction of the ceiling joists relative to the vehicle. Each lifter cable will fall along either side of the hard top. The carabiners will be hooked to the rails 15" from the myLifters. This forms a 15-inch square on the ceiling.
4. Pair the Lifters to the App and create a "locked group." Refer to the MyLifter Manual for App instructions



CAUTION

Be sure to measure the 15-inch square when the cable is mostly retracted.

SMARTTRACK

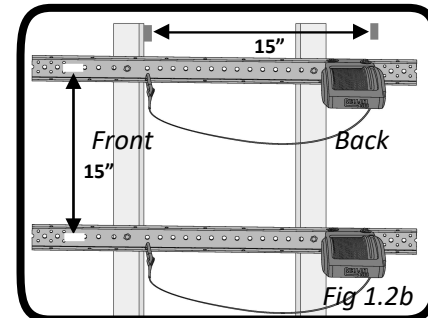
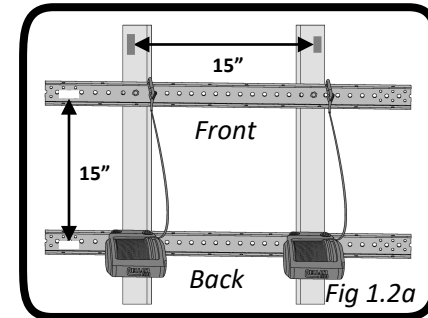
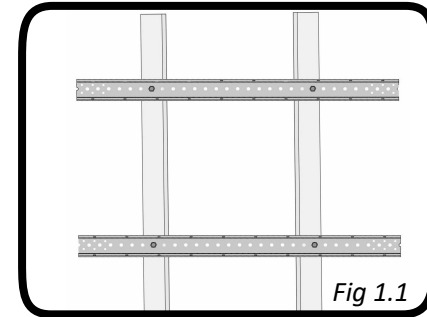

HARDTOP LIFTER INSTALLATION

SMARTTRACK TROUBLESHOOTING

5. Power Adapter Layout

- Depending on your orientation, Power Adapters can be laid out as shown or in other configurations. (Fig 1.5.1)
If there are no outlets near the lifters, the power adapters can be placed on a separate track or on a stud. (Fig 1.5.2)

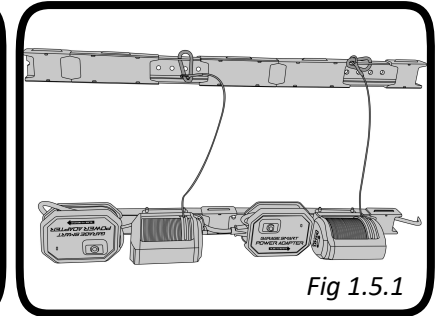
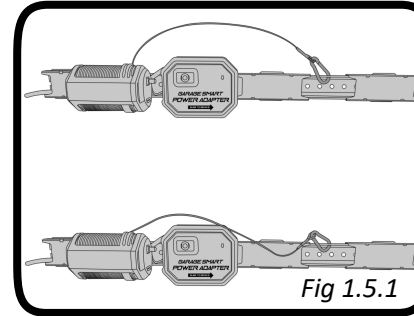

THESE PICTURES SHOW SEVERAL POSSIBLE PROBLEMS WITH SMARTTRACK INSTALLATION.

- Because the clip was placed on the wrong side, the lifter will misalign the hard top.
- Spacing is also incorrect (18") when cable is retracted.
- These two hooks are also misaligned when the lifter is retracted.
- Placing the clip on the wrong side of the track will cause the wrong spacing.
- Cable wraps under the lifter.

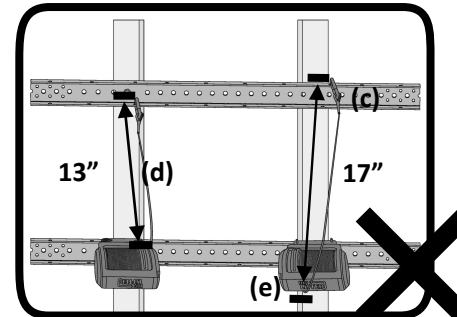
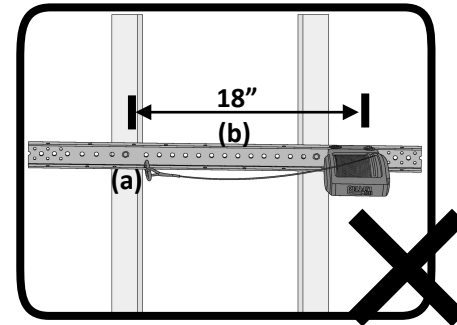

HARDTOP LIFTER INSTALLATION

ASSEMBLY

2. Length Adjuster

1. There are four length adjusters (each with 34 holes), two narrow (**B**) and two wide (**A**). Lay the narrow ones inside the wide ones with the square holes at opposite ends. (*Fig 2.1a*)

Both u-shaped bars open upward. These will later be pinned in place. (*Fig 2.1b*)

2. Slide the width adjusters (**C**) through the square holes as shown. Align holes with length adjuster openings as shown. (*Fig 2.2*)

3. Assemble all six pieces together. (*Fig 2.3*)

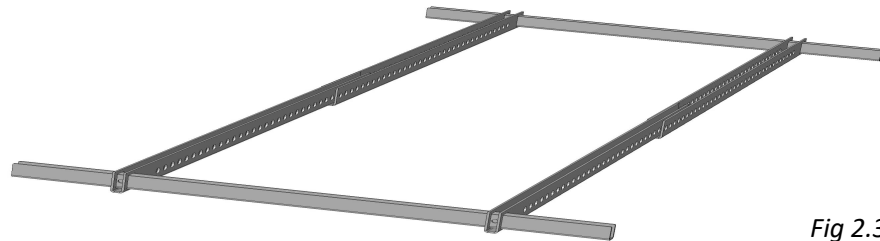
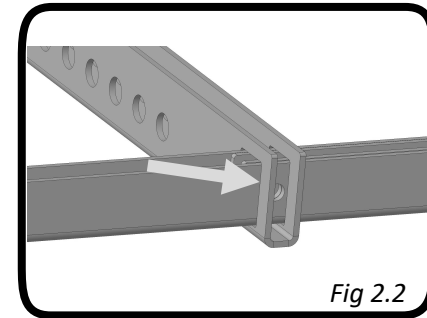
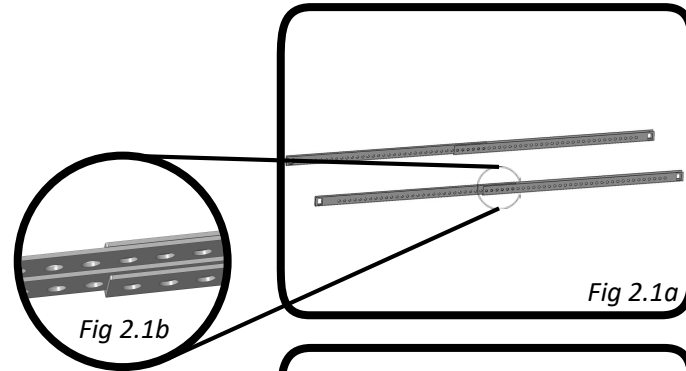

Fig 2.3

HARDTOP LIFTER INSTALLATION

ASSEMBLY

3. Width Adjuster

- Slide the narrow width adjusters (with the hook ends) into the wider ones *and* through the square end of the length adjuster. The short width adjusters (**D**) go in back and the long ones (**E**) in front.
- Place long pins (**F**) so that each pin holds three parts in place. Adjustments can be made later. (Fig 3.2)

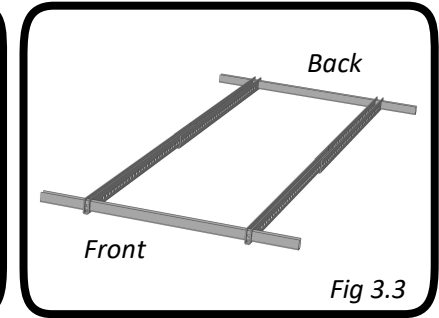
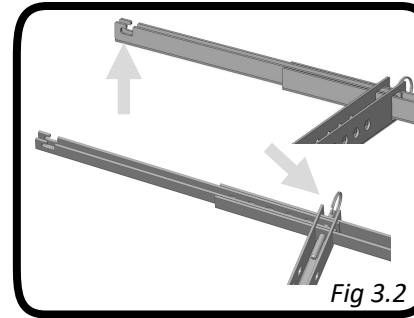

NOTE

The front and back half of the frame are still not connected. (Fig 3.3)

4. Foam Blocks

- Slide the foam blocks (**H**) onto the width adjusters in the positions shown. (Fig 4.1)

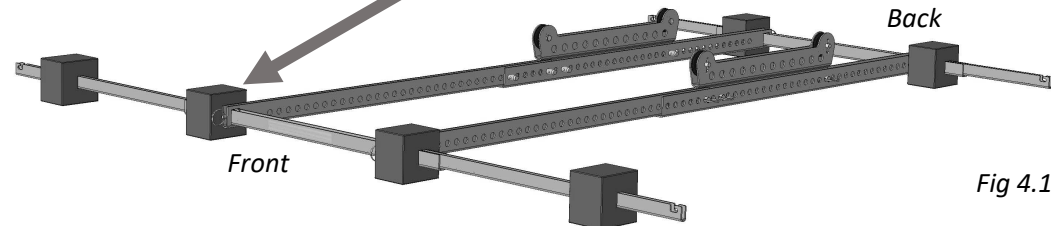
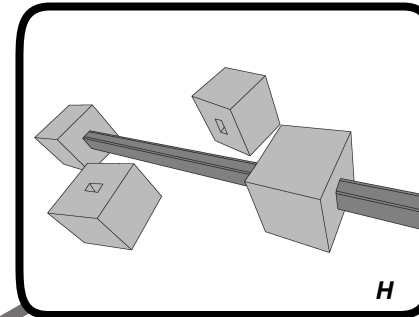

HARDTOP LIFTER INSTALLATION

ASSEMBLY

5. Pulley Sliders

1. Set the pulley sliders (I) at equal positions anywhere along the groove of the length adjusters and secure them with the short quick-release pins (G).

NOTE

A good starting point for the common 4-door Jeep top is to place the short pins through the back of the pulley frame (I) and the 14th hole from the back of the length adjuster (A).

2. Also place short pins in the last hole of each length adjuster, even if it passes through the pulley holder again. While 8 pins are provided, they may not all be necessary for some configurations. (Fig 5.2)
3. Place the frame under the myLifters and extend the myLifter cables long enough to reach the floor and up again.



CAUTION

For V1 lifters, be sure to keep weight on the cable as it extends.

4. Pass each cable through the appropriate pulley frame. One cable should pass through one frame under both pulleys. Hook the cable eyelet with the carabiner to the track. (Fig 5.4)

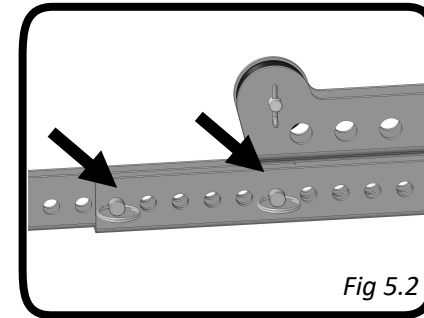

Fig 5.2

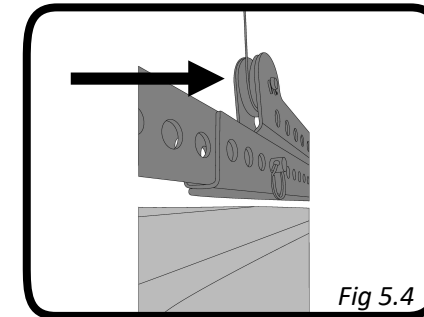

Fig 5.4

HARDTOP LIFTER INSTALLATION

VEHICLE

6. Vehicle Installation

1. Lift the frame above the height of the vehicle's top. Position the vehicle under the frame and then lower the frame onto the roof. Perfect alignment is not necessary, but try to get close.
2. Adjust width by removing the long pins, repositioning the adjuster arms, and replacing the pins. (Fig 6.2) Similarly, set the front to back length to be 4-6 inches longer than the vertical side of the hard top.

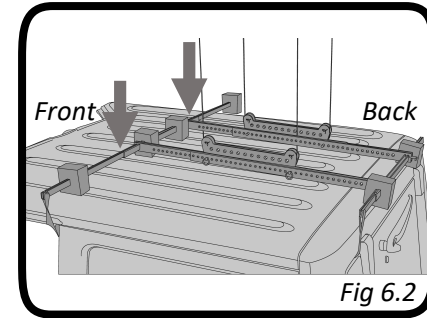

NOTE

The frame will not lift level when unattached to the hard top. It should be leveled after the hard top is attached and all cargo stowed.

3. Set the "Lower Smart Point" in the App. Refer to the MyLifter Manual for App instructions.



HARDTOP LIFTER INSTALLATION

CARGO NET AND CONFIGURATION

7. Cargo Net Installation and Configuration

1. The non-adjustable ends of the cargo net (**K**) attach to the back of the frame. (Fig 7.1a)

Pass them between the window and the hardtop, and between the gas shocks. (Fig 7.1b)

Feed the front, adjustable end of the net over any roll bars, or other items, and hook the loops to the front of the frame.

2. Attach loop by first sliding it past the hook then feeding it into the hook. (Fig 7.2a, b, & c)

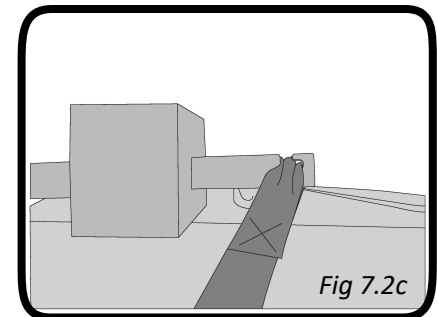
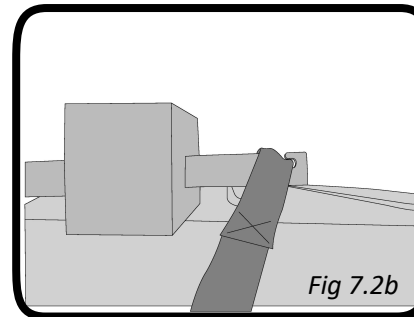
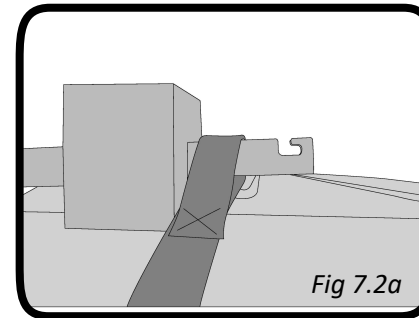
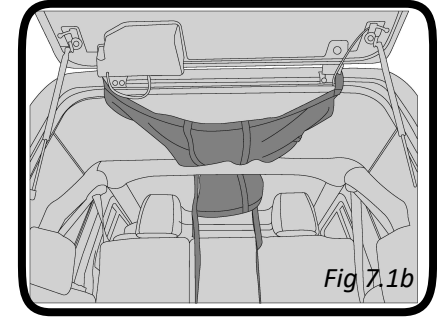
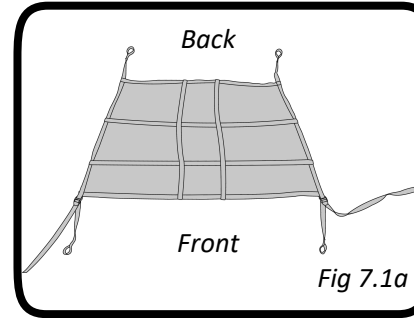

HARDTOP LIFTER INSTALLATION

CARGO NET AND CONFIGURATION

7. Cargo Net Installation and Configuration

3. Tighten straps.



CAUTION

Be sure that all load bearing straps do not rest on any fragile item.

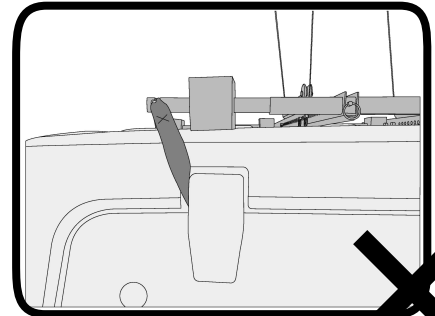
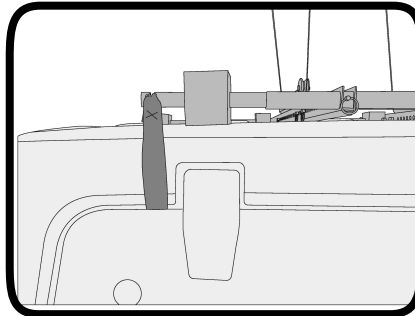
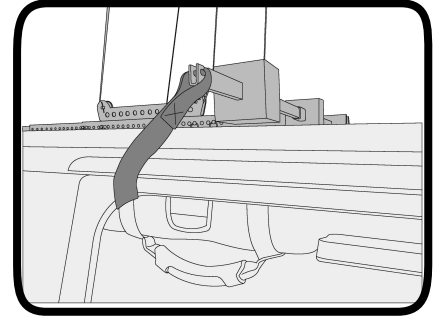
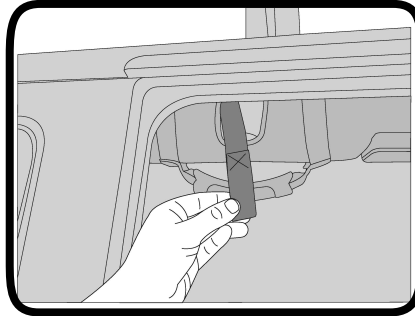

HARDTOP LIFTER INSTALLATION

ADJUSTMENTS

8. HardTop Lifter Adjustments

1. Unbolt the hard top from the vehicle and slowly lift it free. (Fig 8.1)



CAUTION

Be sure to remove all bolts, and unhook all electrical and fluid lines according to your vehicle owner's manual.

2. Make sure cargo net straps are snug. Lift to about head height and place any additional pieces or small doors into the cargo net. A moving blanket is recommended to protect painted items. (Fig 8.2)



CAUTION

Do not overload your cargo net while HardTop is in the lifted position, or it will not lower.

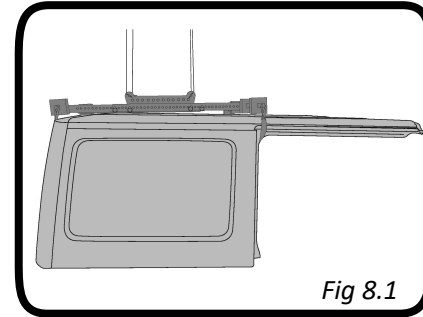

Fig 8.1

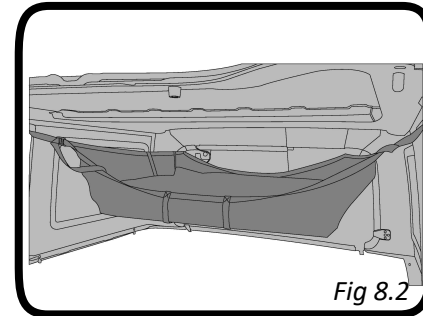

Fig 8.2

HARDTOP LIFTER INSTALLATION

ADJUSTMENTS

8. HardTop Lifter Adjustments (cont.)

3. If the hard top is leaning forward, move the vehicle and lower the hardtop to the floor. Move the pulley sliders forward a little, without changing the frame length adjustment; re-pin then lift again. If leaning backward, move the sliders back.
4. Repeat until the load is balanced. (Adjustments are only necessary during setup. Subsequent removals should not need any adjustment.)
5. Lift to the ceiling. Set the “Upper Smart Point” in the App. Refer to the MyLifter Manual for App instructions.



CAUTION

Do NOT run the Pulley Sliders into the myLifter.



FAQs

How much weight can my Hard Top Kit lift?

Since this product is designed to use two lifters, and it weighs about 25 lbs, the kit can lift about 175 lbs. DO NOT use more than two lifters to lift more than the designed weight limit.

How much weight can the cargo net hold?

The net is supporting BOTH the hard top and it's cargo. It can hold up to 175 lbs *IF* the weight is evenly distributed. DO NOT point load the fabric or hang all the weight on one strap only.

Will this kit fit my vehicle's hard top?

See the list of tops this kit is known to fit (available at www.garagesmart.com). See the measurements to determine if it will work for other hard tops. (Buyer assumes any risk from use on tops other than those listed.)

Why is my hard top tilting forward or back?

If it is tilting all the time, the pulley frames need to be moved toward the lower end of the hard top.

If it is only tilting while lifting or lowering, the lifter cable may have come off the pulley or a pulley may be rubbing. Contact the manufacturer if the pulley is rubbing.

Why is my hard top tilting side to side?

One of two reasons:

1. The calibration in the App is off. Level the group in your App settings. See myLifter Manual for full leveling instructions.
2. The lifting frame is not placed above the center of the hard top. If not all width adjustments are symmetric, the frame will sit off center.

What if my ceiling joists spacing prevent me from placing my lift frame where I want?

If joist spacing is a problem, purchasing two more lengths of track will allow you to span more joists and provide more placement options. They are available for purchase at www.garagesmart.com.