



OWNER'S MANUAL

CYKE

FALCON A

You should also read the entire Owner's Manual because it has additional important general information and instructions which you should follow. If you do not have a copy of the Owner's Manual, you can download it at no cost at cykebikes.com



CONTENTS

ABOUT THIS MANUAL 1

Maintenance, Adjustment and Repairs.....	1
Symbols.....	1

GENERAL INFORMATION 2

Intended Use.....	2
Specifications.....	2
Components.....	3

GENERAL NOTES ABOUT RIDING 5

Motor Assistance.....	5
Brake.....	5
Changing Gears.....	5
Electric Bicycle Riding Tips.....	6
Before Riding.....	7

GENERAL NOTES ABOUT ASSEMBLY 9

Attaching the Front Wheel.....	9
Attaching the Pedals.....	10
Seat Tube Height Adjustment.....	11
Handlebar Adjustment.....	12
Air Pressure and "SAG".....	14
Setting the "SAG".....	14

Setting the Air Pressure.....	15
Air Volume Adjustment.....	16
Rebound Damping Adjustment.....	18
Compression Damping Adjustment.....	19
Lock Operation.....	22
Shock Absorber Maintenance.....	23

HMI DISPLAY CONTROL..... 25

HMI Display Buttons.....	26
Boot Animation Display.....	27
Power-Assisted Mode Selection.....	27
Boost Mode Description.....	29
Multifunction Selection.....	30
Battery Capacity Indication.....	31
Bluetooth Function.....	31
USB Charge Function.....	31
Data Summary Interface.....	32
Setting interface.....	33
Instrument Parameter Setting Interface.....	35
Information Viewing Interface.....	38
CYKE Assistant APP.....	42

BATTERY AND CHARGER..... 43

Battery Charging.....	43
Battery Removal and Insertion.....	45

Operating Instructions.....	46
Battery Storage.....	47
MAINTENANCE.....	49
Basic Bike Care.....	49
Cleaning Your CYKE.....	49
Tire Inflation and Replacement.....	50
Recommended Service Intervals.....	51
Troubleshooting.....	52
WARRANTY POLICY.....	53
Length of Warranty.....	53
Warranty Conditions.....	53

ABOUT THIS MANUAL

Keep this Owner's Manual in a safe place for future reference. All content in this manual is subject to change as we continually work to refine our products.

This manual contains warnings, cautions, and notes for your safety. Carefully read all of this information and share with others who may ride this bike before attempting to operate the bike for the first time. Give special attention to any information that has a warning or caution symbol before or next to it. Also pay attention to any information preceded by NOTICE as this will be important information that may not be related to safety.

Always properly maintain and care for your bicycle so original quality and safety are retained.

Maintenance, Adjustment and Repairs

To reduce the risk of accidents and injury, regularly inspect your bicycle and have it repaired at our authorized distributors or after-sales service shops. Assembly and adjustment of this bike may require special tools and skills. It is recommended that the assembly and adjustment of this bike be completed by a certified, reputable bike mechanic if possible.

All users must read and understand this manual before riding their bike from a CYKE bike. Additional manuals for components used on the bike will also be provided, please read before installing or using.

Symbols

The safety symbols listed below indicate that the message followed is related to safety. Failure to pay attention to the safety message may result in property damage, injury or death.



WARNING! Indicates a hazard or unsafe practice that can result in severe injury or death if the user fails to read, understand and follow the safety information in this manual.



CAUTION: Indicates a hazard or unsafe condition that could result in minor injury if the user fails to read, understand and follow the safety information.



NOTICE: Indicates information that the user should pay special attention to but is not related to physical injury.

GENERAL INFORMATION

Always carry out a complete check before riding. Thoroughly read the safety section. Electric Bicycles can be dangerous to use. The user or consumer assumes all risk of personal injuries, damage, or failure of the bicycle or system and all other losses or damages to themselves and others and to any property arising as a result of using the electric bicycle.

Never disassemble, modify or replace electrical parts.

Always wear an approved helmet when you are riding to protect your head in a fall. It is your responsibility to familiarize yourself with the laws of where you ride your CYKE bike in advance and comply with all applicable laws.

Intended Use

This bicycle is designed for riding on smooth gravel roads and improved and moderate-grade trails where the tires do not lose ground contact. These bicycles are intended for paved roads, gravel or dirt roads that are in good condition, and bicycle paths.

Specifications

Model Name	FALCON A
Max. Load Capacity	220LBS / 100KG
Top Speed	Default: 20MPH Max: 28MPH
Motor	48V 500W Mid-driven motor
Battery	48V 15AH
Wheel Size	27.5"x3.0" Front/Rear
Charger	48V 3A
Charging Time	Approx.6-8 Hours
Water Resistance	IPX5
Net Weight	55LBS / 25KG

Components

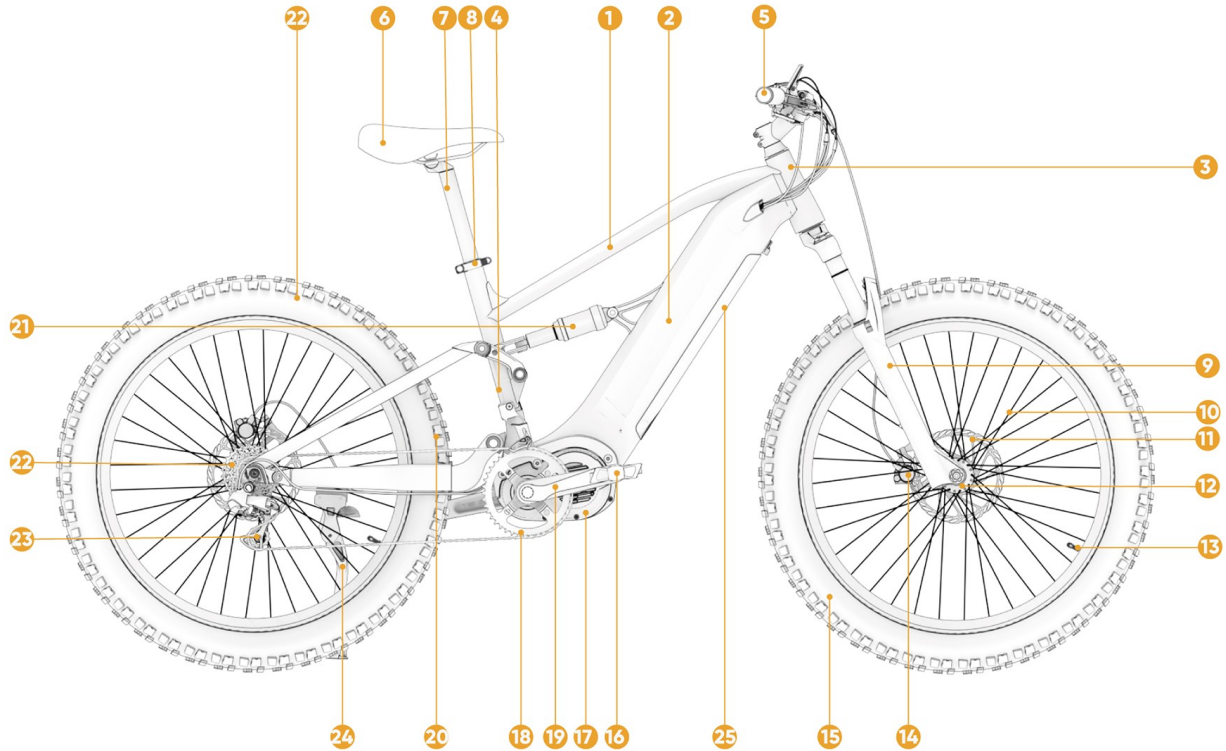

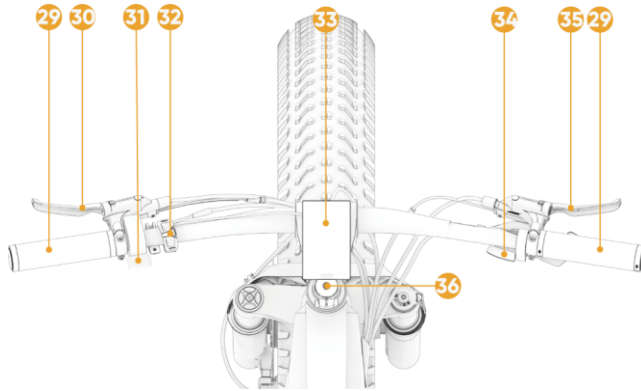
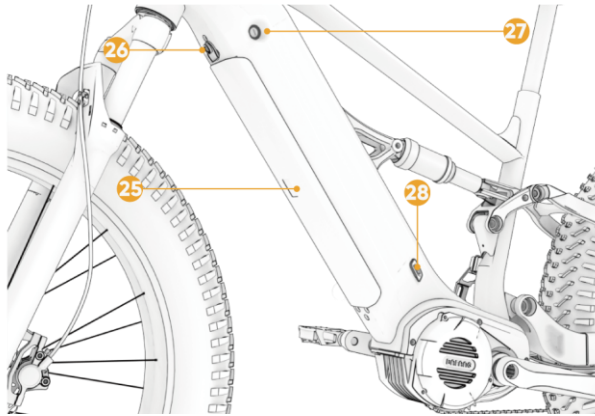

1	Top tube	16	Pedal	31	Thumb throttle
2	Down tube	17	Controller box	32	HMI Controller
3	Head tube	18	Chainring	33	HMI display
4	Middle tube	19	Crank arm	34	Shift lever
5	Cockpit	20	Chain	35	Rear brake
6	Saddle	21	Shock Absorber	36	Stem cap
7	Seat tube	22	Rear tire		
8	Seat tube clamp	23	Rear derailleur		
9	Fork	24	Kickstand		
10	Spoke	25	Battery		
11	Brake rotor	26	Safety lock		
12	Wheel bolt	27	Battery lock		
13	Valve	28	Charging socket		
14	Brake caliper	29	Grips		
15	Front tire	30	Front brake		



NOTICE: The appearance of components slightly varies between different batches, therefore the pictures in this manual are for reference only but do not affect the description and interpretation of the product. Please refer to the actually received ones.

GENERAL NOTES ABOUT RIDING

Motor Assistance

When riding, the sensor at the crank can feel the person's pedaling force or pedaling speed, and control the assist intensity according to those. The harder or faster you pedal, the greater the assist is.

Your CYKE bike can also be ridden like a regular bicycle without motor assistance by switching the assist level to PAS0 (OFF) on the display.

As mentioned in this manual, with the system powered up, the motor support will activate as soon as the cranks are rotating. This can also happen when not actively riding the bicycle, e.g., when the bicycle is in a work stand or flipped upside down and the cranks are turned or the chain is moved (which then turns the cranks), when walking alongside and pushing the bicycle and the cranks are turned, or any other scenario where the cranks are turned, and the wheels are moving, whether intentionally or unintentionally. What this means is that the system should be powered off when motor assist is not desired to avoid any unintentional engagement of the motor.



WARNING! The system must always be powered off when not in use or performing any maintenance on the bicycle.

Brake

Sometimes the motor doesn't stop working immediately when you stop pedaling, you need to cut off the power by pinching the brake.



WARNING! CYKE bike is equipped with brake sensors, so do not replace the brakes.



WARNING! Be careful to keep body parts and other objects away from the moving disc brake rotors to avoid injury. Also, disc brake rotors can get extremely hot with extended use. Be careful and do not touch a rotor until it has plenty of time to cool.



CAUTION: Do not allow any oil or grease to get onto the disc brake rotor and the brake pads. Riding the bicycle with oil or grease on the disc brake rotor and brake pads may prevent the brakes from operating correctly.

Changing Gears

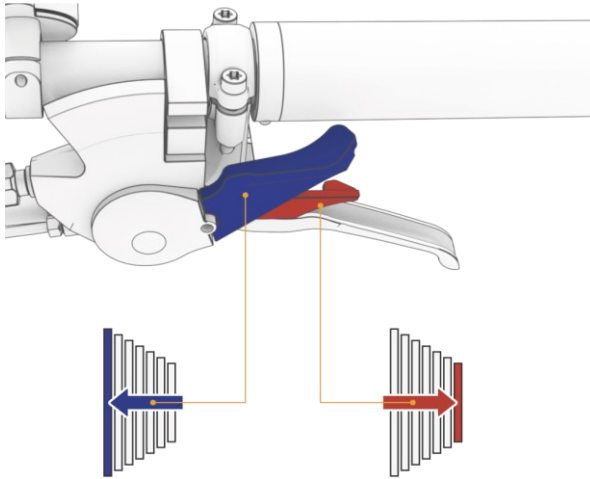

When pedaling, pull the upper lever with your index finger to shift your bicycle into a higher gear (harder/small cog) and push the lower lever with your thumb to shift your bicycle into a lower gear (easier/large cog).

CAUTION: Do not shift gears when applying full force on the pedals. Change one gear at a time and only when pedaling. At the same time, when riding uphill, please place the gear in the larger gear plate in advance to climb the hill.

Electric Bicycle Riding Tips

Because of the electric motor assist, your electric bicycle offers a unique riding experience compared to a normal bicycle.

Below are some riding tips and information that may reduce component wear and increase battery range:

- Please pay attention to your speed going into a corner and stop pedaling before entering it. Otherwise, you may carry too much speed which may cause you to lose control and fall.
- Ride at a comfortable, efficient cadence and look ahead.
- When braking force is applied, more energy is needed to get the bicycle back up to speed.
- Shift gears regularly to stay in an optimal cadence range and downshift before coming to a stop.
- Reduce pedal force before initiating a gear shift to reduce drivetrain wear.
- Braking while steering may reduce the ability to control your bicycle.
- Only carry the cargo you need. More weight drains the battery faster.
- Do not expose your bicycle to prolonged excessive heat.
- Check the tire pressure regularly as low pressure can cause the tires to roll inefficiently.

Before Riding

Regardless of your experience level, you should check the following every time before you start to ride an E-bike:

Check Item	Basic Steps
Wheels and Tires	<ul style="list-style-type: none"> ● Ensure the tires are inflated to the recommended limits specified on tire side wall. ● Inspect tires to ensure the tread is good, with no bulges or cuts, and not embedded objects that may puncture it. ● Ensure the rims run well, do not wobble, and have no damage, nor dents and kinks. ● Ensure all spokes are tight and are not broken. ● Make sure axle nuts or quick release levers are tight. ● Ensure the locking levers of all quick release assemblies are secured. ● Ensure that reflectors are securely in position on both wheels.
Brakes	<ul style="list-style-type: none"> ● Ensure front and rear brakes function properly. ● Test and ensure that the brake levers are firm, move freely, and do not touch the handlebar grips when pulled with maximum hand force. ● Ensure the brake pads are positioned correctly, move freely, and do not have excessive wear. ● Inspect the brake rotors to make sure they are not damaged, with no excessive wear or objects tangled in them. ● Ensure brake cables are adjusted correctly, lubricated well, and have no obvious damage. ● Ensure brake caliper fasteners are secure, without leaking fluid or any, damage.
Steering	<ul style="list-style-type: none"> ● Ensure that the handlebars and stem are correctly adjusted, tightly fastened, and turn freely.

	<ul style="list-style-type: none"> ● Ensure the handlebars and stem are set correctly in relation to the front wheel. ● Ensure both handlebar grips are secure and do not have excessive wear.
Chain	<ul style="list-style-type: none"> ● Ensure the chain is clean, well lubricated, and runs smoothly. ● Make sure the chain does not make any unusual noises or squeaks. ● Make sure there is no foreign material lodged in the chain links or excessive corrosion.
Bearings	<ul style="list-style-type: none"> ● Ensure the bearings in the headset, lower bracket, pedals, and both wheels run freely. ● Inspect and ensure there's no excess movement, rough feeling, grinding, rattling, or noise.
Cranks and Pedals	<ul style="list-style-type: none"> ● Make sure both pedals are securely tightened to the crank arms. ● Ensure the pedals turn freely, not bent or damaged in any way. ● Make sure the crank arms are securely fastened to bottom bracket shaft and not bent.
Rear Derailleur, Shifter, and Shift Cable	<ul style="list-style-type: none"> ● Check that the derailleur is adjusted well and function properly. ● Ensure the shifter is functioning properly when shifting up and down through gears. ● Ensure the chain is not making noise in all gears. ● Ensure the derailleur is moving freely, tightly secured with the shift cable, and without any objects tangled in it. ● Ensure the shift cable is not damaged in any way and is properly adjusted.
Frame, Fork, and Seat	<ul style="list-style-type: none"> ● Make sure the frame and the front fork are not bent or damaged in any way. ● Inspect frame and fork for any cracks in the paint at the welded joints, as this may indicate damages to the frame or a broken weld.

	<ul style="list-style-type: none"> ● Make sure the seat is properly adjusted and the quick release is securely tightened. ● Ensure both wheels in the front and rear are evenly spaced.
Motor and Rear Wheel Assembly	<ul style="list-style-type: none"> ● Ensure the rear wheels rotate smoothly in both directions. ● Ensure the front and rear wheel bolts are tight and there is no sign of damage when the rear part comes off. ● Ensure the spokes are tight and not damaged in any way.
Battery	<ul style="list-style-type: none"> ● Make sure the battery is fully charged before using the ebike. ● Inspect the battery to ensure there is no damage to the battery, the electrical connectors are in good condition, and the mounting features are in good condition. ● Insert one side of the battery into the lower battery holder and lock the other side into the upper holder. Make sure the battery is held firmly in position by the lock. ● Pull lightly on the battery to make sure it will not come out after being locked. ● Turn on the HMI display to confirm that the battery is well engaged and fully charged.
Electrical Cables and Lights	<ul style="list-style-type: none"> ● Inspect all visible electrical connectors to confirm they are connected completely. ● Make sure all electrical cable grommets are in the proper position to prevent damage to electrical and mechanical cables. ● Ensure the cable insulation is not damaged and there are no exposed wires.
Accessories Other, and PPE	<ul style="list-style-type: none"> ● Ensure all reflectors on bike are properly secured and visible. ● Ensure the rear rack or any other items are securely fastened to the frame. ● Ensure the fenders and mounting hardwares are secure.

	<ul style="list-style-type: none"> ● Make sure the kick stand is functioning properly and fasteners are tight. ● Inspect the helmet and any other PPE to ensure they are not damaged and function properly. ● Ensure the rider is wearing a helmet or other required PPE, and is familiar with riding laws.
Shock Absorber	<ul style="list-style-type: none"> ● Use your body weight to compress your rear shock. If it feels too soft, relate to proper pressure to get accurate SAG, please inflate it until it reaches the desired value.

GENERAL NOTES ABOUT ASSEMBLY

Attaching the Front Wheel

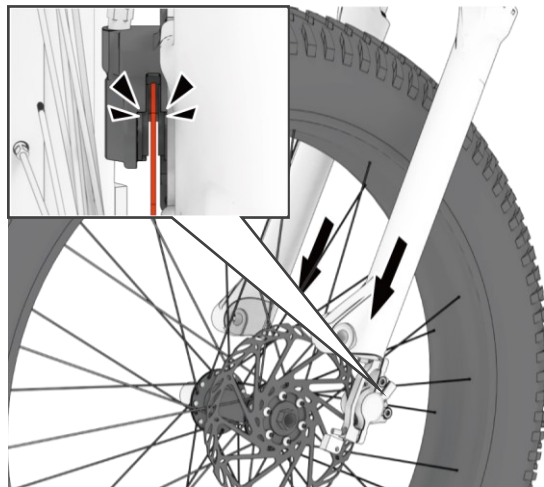

First, remove the brake protection plate, and slide the front wheel into the front fork, so that the disc brake is inserted into the center of the brake caliper, while the front hub axle is stuck into the front fork slot.

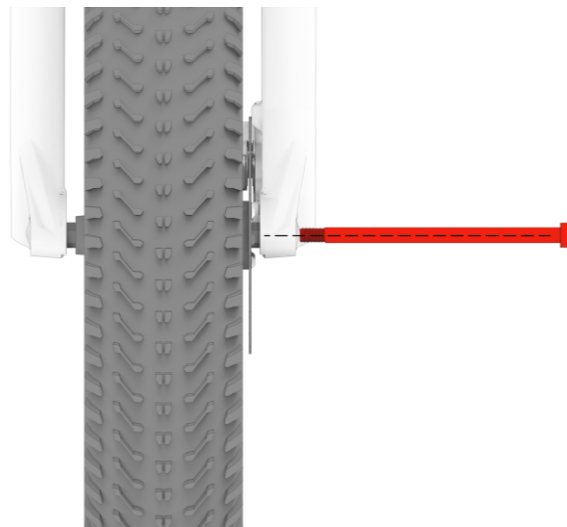

Take out the bolt, pass it through the front wheel hub and tighten it clockwise using an M6 wrench.



WARNING! Please ensure that there is a proper gap between the brake disc and the brake pad in case of disc collision, which may cause damage to the brake kit or even pose a major threat to personal safety.

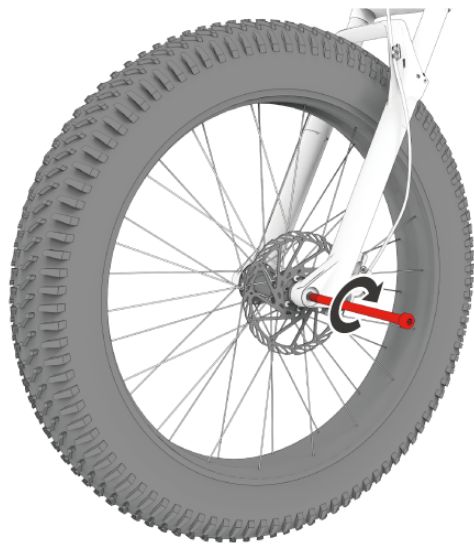

Tighten clockwise

Attaching the Pedals

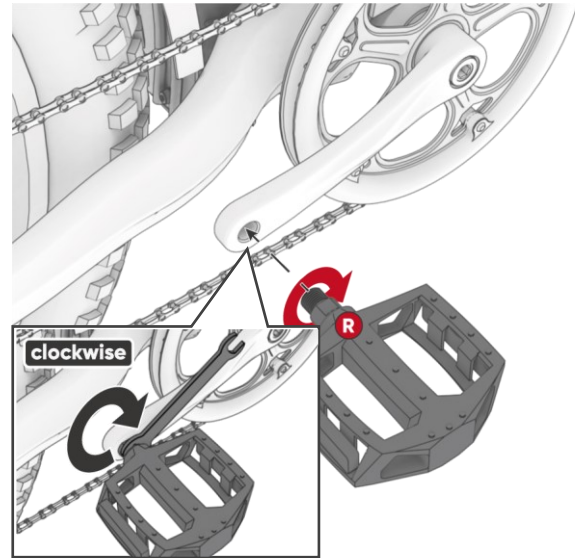

Insert the right pedal ("R" sticker) into the right crank's threaded hole and rotate the pedal (clockwise) until some tension is felt.

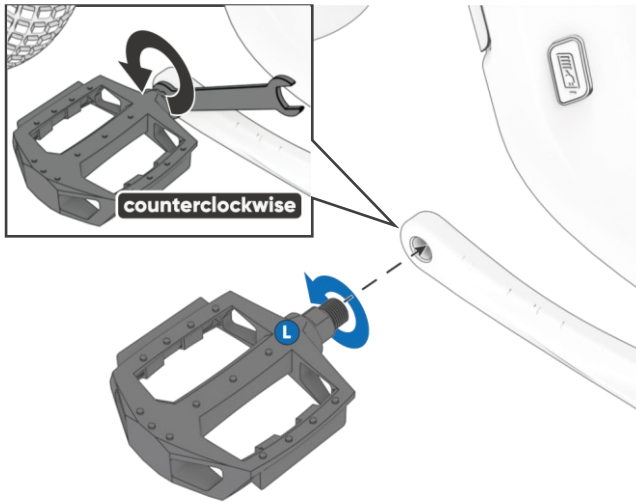

Repeat these steps for the left pedal ("L" sticker) in the left crank, but rotate and tighten the pedal counterclockwise.



CAUTION: Make sure to install the pedals correctly. The left and right pedals have opposite threads and can damage the cranks if installed on the wrong side.

Seat Tube Height Adjustment

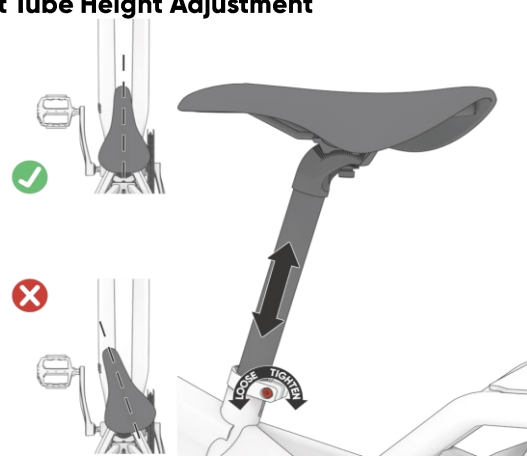

Loosen the adjusting bolt of the seat clamp and adjust the seat tube to the appropriate height. Then lock the seat clamp and make sure the stationary saddle faces forward.



WARNING! Do not set the height of the seat tube too high and over the warning line, for this may cause the seat tube to fall off and lead to risk.



NOTICE: Sit on the e-bike with the pedal in the 6 o'clock position. Make sure the angle between your calves and thighs is between 145 and 155, as this is the best position of the seat that fits you best. Maybe it's difficult for you to touch the ground at this height, which is normal. But at this height, you are able to generate the power better and protect your knees.

Handlebar Adjustment

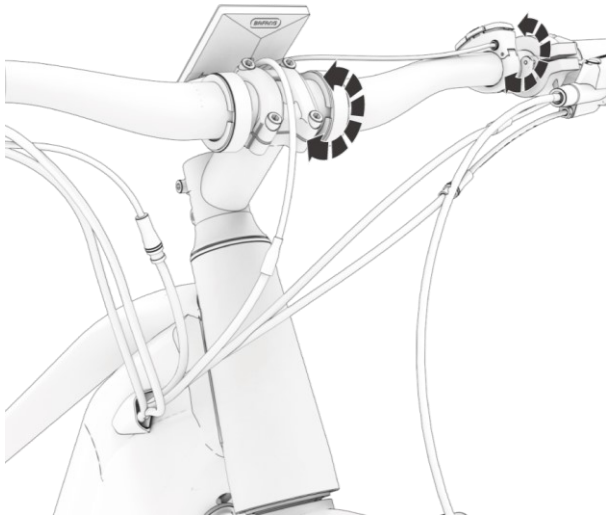

Loosen the front bolt on the stem and adjust the handlebar to the right angle.

Then tighten the front bolts in a diagonal sequence.

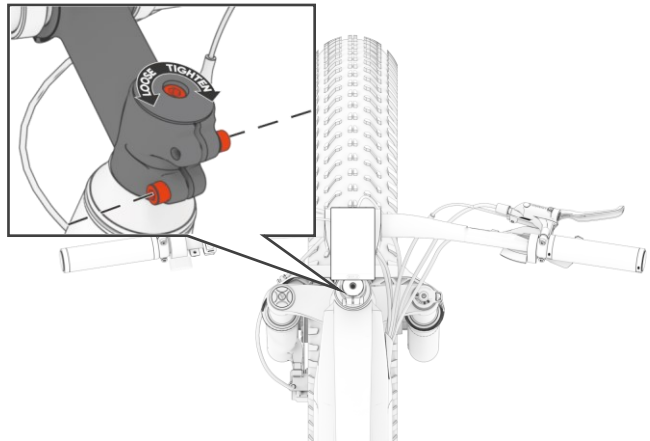

Loosen the screws on the stem and stem cap, push the front wheel against the wall, and adjust the direction of the stem so that it is in line with the front wheel. Make sure the handlebar is perpendicular to the front wheel and press down on the handlebars and tighten the stem cap screw. Finally, make sure that the handlebar is perpendicular to the front wheel and tighten the screws on both sides of the stem.

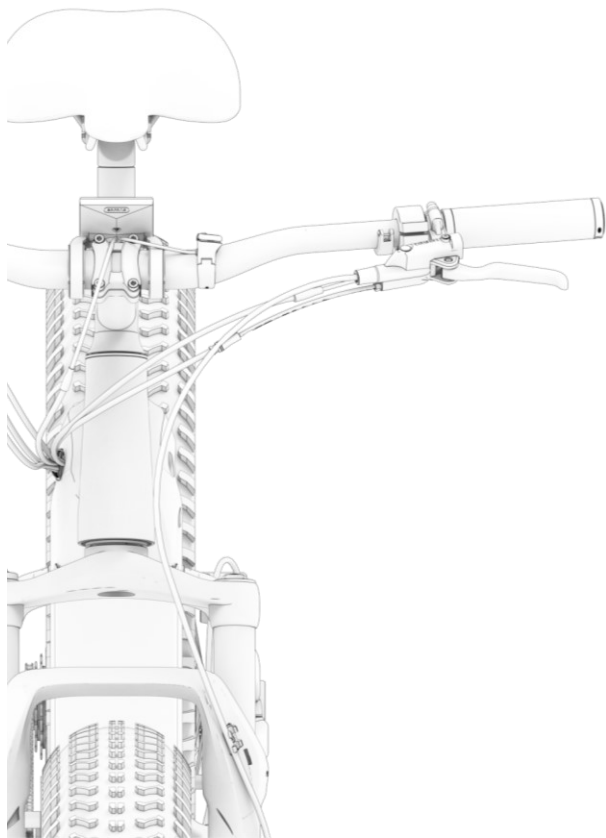

WARNING! Make sure that the handlebar is firmly fixed. If rotate the handlebar but find its connection with the front fork is loose, please adjust the handlebar according to these steps again.



NOTICE: The position of the brake, switch, display, and other components on the handlebar can be adjusted after loosening the bolt. Everyone's physique and riding habits are different, please adjust the components to the position for better operation.



WARNING! Please ensure that the bolts are tightened after all adjusting to avoid losing during the ride, causing the risk of losing control.



Visit our channel for more assembly guide videos

Air Pressure and "SAG"

For optimal performance from your SR SUNTOUR air spring rear shock, adjust the air pressure to obtain the proper SAG value. The SAG value refers to how much the shock compresses under your weight, riding equipment and luggage. Make sure the depression range is in the total shock travel and is set with the compression knob in the open position.

- The following table is the recommended SAG range and original air pressure table for the SR SUNTOUR air spring rear shock. Note that this is the recommended setting range. Adjustments will vary based on rider ability, off-road conditions, frame design and personal preference.

Shock absorber travel(mm)	SAG(%)	SAG(mm)
75	25-35	18.75 – 26.25
70		17.50 – 24.50
65		16.25 – 22.75
60		15.00 – 21.00
55	25-30	13.75 – 16.50
50	20-25	10.00 – 12.50
45		9.00 – 11.25
40		8.00 – 10.00
35		7.00 – 8.75
30		6.00 – 7.50

After setting up the shock absorber, check your SAG settings to make sure you are within the recommended SAG settings.

- SAG is compression caused by the weight of the rider (including equipment (e.g. backpack), saddle position and frame geometry), not the riding. Every rider has a different weight and seating position, so the shock will compress more or less. To ensure correct rear shock absorber.

Working regularly without affecting its performance, setting up a proper SAG is an important way to find the right air pressure for your shock absorber.

Setting the "SAG"

1. Apply the recommended air pressure and test the pressure several times, compressing at least 50% of the full stroke to balance the air pressure between the positive and negative air chambers.
2. Sit on your bike with equipment (such as a backpack), have someone support your bike, stand on the pedals, and compress the shock absorbers a few times. Then sit on your bike in a normal riding position.
3. Slide the SAG indicator O-ring down onto the top of the dust seal.
4. Gently dismount from your vehicle without further compressing the shock absorbers.
5. Check the position of the O-ring to see if the SAG setting is correct.

6. If the SAG settings are incorrect, the air pressure must be adjusted.

7. Repeat the above process until the correct SAG settings are found.



NOTICE:

To increase SAG, lower the air pressure.

To reduce SAG, increase air pressure.

Setting the Air Pressure

Below are the shock's original air pressure settings from the factory. Remember, these are initial settings and adjustments will vary based on rider ability, track conditions, frame design, and personal preference. Check the SAG to make sure you are within the recommended SAG value settings.



NOTICE: It's important to remember that air pressure will vary depending on the leverage of the frame. The correct air pressure may vary depending on the frame design and must be adjusted by the rider when checking the SAG.

Cyclist weight (kg)	Recommended air pressure (psi)													
	Vorocoil		Triair2		Triair		EDGE-comp		EDGE-plus		EDGE		RAIDON	
	Main body	Liquid storage tank (IFP)	Main body	Liquid storage tank (IFP)	Main body	Liquid storage tank (IFP)	Main body	Liquid storage tank (IFP)	Main body	Main body	Main body	Main body	Main body	Main body
Factory set pressure	/	200	180	180	180	200	110	110	110	110	110	110	110	110
Maximum pressure	/	250	300	240	300	240	300	300	300	300	300	300	300	300



WARNING! Riding a bicycle without proper air pressure can result in loss of control, serious injury or even death. Do not exceed the maximum air pressure shown in the diagram above. This can result in damage to the rear shock, serious injury, and expiration of the shock's warranty.

Air Volume Adjustment

If you are looking for further tuning, the spring curve of the air shock can be adjusted by using volume spacers. Air pressure should be used to achieve the correct SAG. If harshly bottomed out, the volume spacers will control the progressiveness of the shock.



NOTICE: Be careful of contamination when removing the air sleeve. Dirt in the air chamber can cause leaks or malfunctions. Always keep your shock absorbers clean while performing this procedure

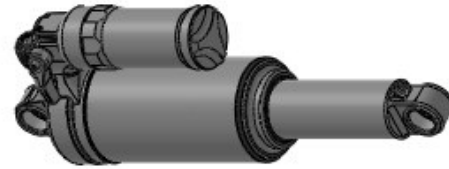

1. Let all air out of the main canister. Remove the o-ring underneath the air chamber. Be cautious not to damage the o-ring.



2. Twist and push downward to remove the HV (high volume) air sleeve.



3. Add or remove your desired amount of air volume spacers. Reinstall the air canister and make sure it is sealed with no gaps present. Reinstall the o-ring and you're ready to ride!

ADDING AIR VOLUME SPACERS

Adding air volume spacers will create a more progressive feeling to your air shock. A more progressive feeling will prevent harsh bottom outs and keep the shock from sitting deep in the stroke.

REMOVING AIR VOLUME SPACERS

Removing air volume spacers will create a more linear feeling to your air shock. A more linear feeling will make it easier to use the full stroke of the shock. If you can't achieve full travel or the shock becomes very harsh towards the end of the stroke, removing air volume spacers will help alleviate that.

Symptom	Solution	
	Positive Chamber	Negative Chamber
Hit bottom too easily	ADDING 1-2 Positive Chamber AIR VOLUME SPACERS	
Lack of support for stampede		ADDING 1-2 Negative Chamber AIR VOLUME SPACERS
Looking for more mid-level support	ADDING 1-2 Positive Chamber AIR VOLUME SPACERS	ADDING 1-2 Negative Chamber AIR VOLUME SPACERS
Unable to use full itinerary		ADDING 1-2 Negative Chamber AIR VOLUME SPACERS and reduce the air pressure

NOTICE:

Air chamber volume adjustable function

Triair2: Positive Chamber+ Negative Chamber

Triair: Positive Chamber+ Negative Chamber

EDGE-comp: Negative Chamber

EDGE & EDGE-plus: Positive Chamber+ Negative Chamber

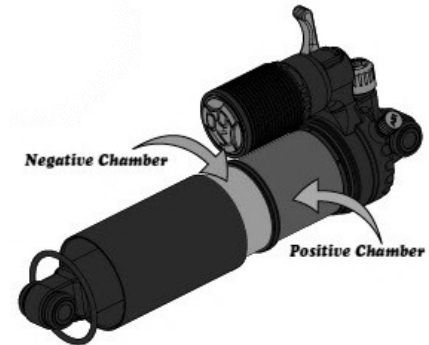

Rebound Damping Adjustment

The rebound controls the speed at which the shock extends after compression. Rebound damping control is relative to the amount of air pressure used. Higher air pressure requires more rebound damping and lower air pressure will require less rebound damping, so please adjust accordingly.

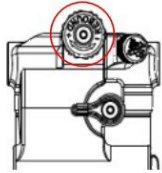

TRIAIR2

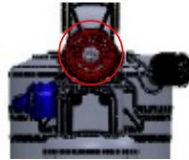

TRIAIR



NOTICE:

SLOWER = More Rebound Damping (Clockwise rotation)

FASTER = LESS Rebound Damping (Anticlockwise rotation)



EDGE-comp



NOTICE:

Rebound settings will vary greatly depending on bike design, track conditions, and rider preference. It's best to start with the rebound adjustment on the off setting (fully clockwise) and then adjust in two-click increments.

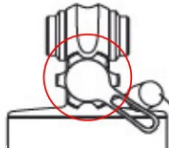

EDGE



RAIDON

Compression Damping Adjustment

Three-stage Low-speed Compression Damping Adjustment

3C COMPRESSION ADJUST

The SR SUNTOUR Triair shock offers 3 compression settings to quickly & easily allow the rider to adjust the compression damping for any trail condition.

1. Open Compression: it reduces compression damping allowing the oil to easily flow through the circuit, offering maximum sensitivity. Open position is also best for lighter riders or for dry, dusty terrain, where maximum traction is required.
2. Medium compression: it is for traversing. Sections of the trail where you need it to be active but still maintain a good pedaling platform.
3. Closed Compression: it is great for climbing, in order to reduce undesirable suspension bob or for heavier/aggressive riders needing maximum support while descending. The heavy/closed setting is NOT a lock-out, but does offer significant resistance to weight & pedal-induc

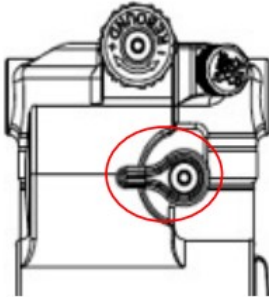

TRIAIR2

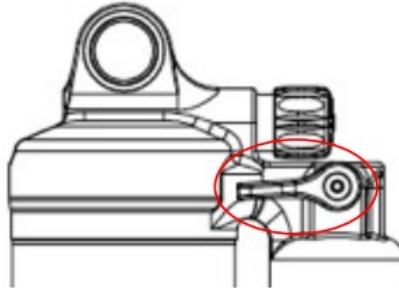

TRIAIR

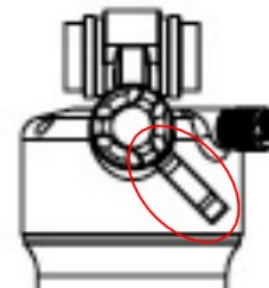

EDGE-comp

Two-stage Low-speed Compression Damping Adjustment

2C COMPRESSION ADJUST

The SR SUNTOUR Triair2, EDGE-comp, EDGE-plus rear shock offers 2 compression settings, allowing the rider to quickly and easily adjust compression damping for any off-road condition.

1. Open type: It reduces compression damping, allowing oil to flow easily through the circuit, providing maximum sensitivity. Open compression is also the best option for lighter riders or dry, dusty terrain where maximum traction is required.
2. Off: It's great for climbing to reduce unwanted suspension. The closed compression setting is not locking, but does provide significant resistance to weight and pedaling-induced suspension movement.

WARNING! Never set the rear shock to "off mode" when riding in rough terrain or when shock is desperately needed. This means there is a risk of damage to the shock absorbers when compressed under high loads. This can also lead to accidents, injuries or even death for the rider.

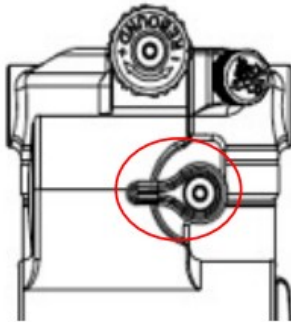

TRIAIR2

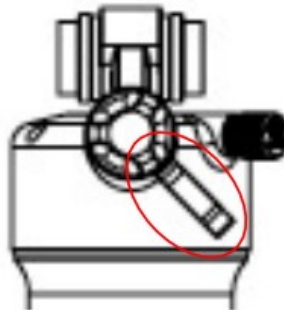

EDGE-comp

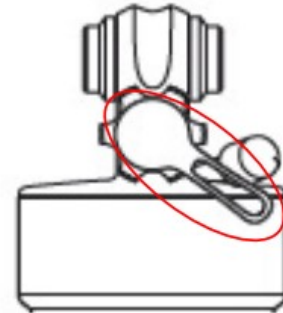

EDGE-plus

Multi:

Multi-stage Low-speed Compression Damping Adjustment

The SR SUNTOUR rear shock's compression damping adjustment lets you tailor the shock to your personal preference and riding terrain. This feature controls the speed of the rear shock during compression.

When riding on terrain with many small, fast bumps:

Choose a faster setting for maximum possible wheel traction and responsive damping. In this mode, your rear shock will react quite sensitively/quickly to every bump. Don't choose this setting on terrain with large bumps and steps, as there will be a higher risk of the rear shock bottoming out.

When riding on large bumps and steps:

Choose a slower setting. In this mode, your rear shock will move more slowly when compressing. Therefore, it will reduce bottoming shock and provide maximum shock absorption. Using this mode on terrain with small, fast bumps will give your bike poor traction. Additionally, if set to slow on fast terrain, the rear shock will not use its full travel.

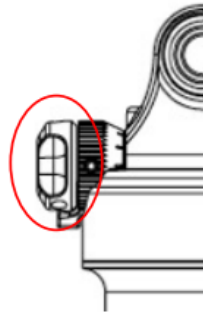

EDGE-RC

Lock Operation

The lockout feature prevents shock compression until a significant impact or downward force occurs. When the force exceeds the damper bleed circuit damping value, the shock will compress. Use the lockout feature for maximum pedaling efficiency on flat or undulating terrain. Operate the locking knob to use the locking and unlocking functions.

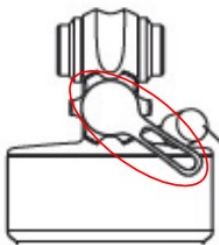

EDGE-plus



NOTICE:

LOR: 100% latching

LOR8: 80% latching

Shock Absorber Maintenance

SR SUNTOUR rear shocks are designed for simple maintenance. However, as long as moving parts are exposed to moisture and contamination, the performance of your rear shock might be reduced after several rides. Please keep in mind that a rear shock which has not been serviced in accordance with the maintenance instructions may lose its warranty !

Never use a pressure washer or any water under pressure to clean your rear shock, as water might enter the shock at the dust seal level. Never use aggressive cleaners. We recommend using clear water.

	Maintenance 1 (Every ride)	Maintenance 2 (Regularly)	Maintenance 3 (every 100 hours / annually whichever comes first)
Clean exterior with mild soap and water only and wipe dry with a soft towel	<input type="radio"/>		
Inspect the shock for visual damage	<input type="radio"/>		
Check the function of controls knobs	<input type="radio"/>		
Check the air pressure (it is normal for air shocks to lose pressure over time)		<input type="radio"/>	
Check the sag and the damper settings		<input type="radio"/>	
Check the mounting hardware for proper torque settings		<input type="radio"/>	
Full shock service including damper rebuild and air seal replacement			<input type="radio"/>

- To maintain a high performance, safety, and long life of your rear shock, periodic maintenance is required.
- We recommend that your rear shock is being serviced frequently as indicated below if you ride in extreme weather (winter time) and terrain conditions.
- In case you feel that your rear shock performance has changed or handles differently, immediately call on your local dealer to inspect your rear shock.
- After every ride: Clean the damper body and dust seals and maintain with an oily cloth. Check the damper body for dents, scratches or other discoloration or leaking oil.
- Every ride: Maintenance 1
- Every 50 hours: Maintenance 2 (at the dealer)
- Every 100 hours or once a year: Maintenance 3 (at the dealer, ideally before winter time in order to protect all parts from the effects of weather by proper greasing)

HMI DISPLAY CONTROL

HMI Display Information





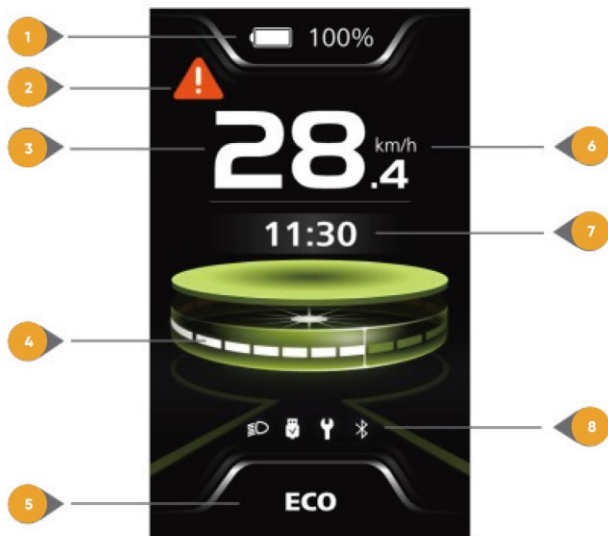

WARNING! Please note that your SR SUNTOUR rear shock is filled with oil and nitrogen. This makes it impossible to open the rear shock without having the knowledge and the special tools on how to carry out this task. Please do not try to open the rear shock for service issues, as this implies a very high risk of getting seriously injured. Besides this, you will not be able to reassemble the shock anymore. Opening the shock will void its warranty. If there is any problem with your rear shock, please consult a dealer and get in contact with SR SUNTOUR.



- 1 Battery indicator: Displays the current remaining capacity.
- 2 Alarm indicator: When the electronic control system fails, it will show and display the fault code, which can be found on the warn code interface or you can check them on the CYKE APP.
- 3 Speed indicator: Displays the current speed.
- 4 Speed bar indicator: Display the current speed in the form of a bar.
- 5 1. Power-assisted mode indicator: Displays the current PAS mode. (4 Modes and 6 Modes are both available to choose). The default is OFF when starting up (no PAS power assist and no steering wheel in OFF mode). Long press the instrument minus in OFF mode to enter the boost promotion mode, and the "🚲" icon flashes.
- 6 Speed unit indicator: Displays the unit of speed: km/H or mile/MH
- 7 Multifunctional indicator: Displays the info of time, single mileage (TRIP), accumulated mileage (ODO), maximum speed(Max), and average speed.
- 8 Icon indicator: Display the status of USB charging, Maintenance prompt, and Bluetooth connection.

HMI Display Buttons



- 1 Power boost button: Press the key  after turning on the power to increase the power gear.
- 2 Power assist reduction button. Press the key  to reduce the power assist gear.
- 3 Instrument power. On button , press  and hold 3S in the off state to turn on the instrument. Press and hold 3S again to turn off the instrument. At the same time, this button can be used as a setting confirmation button. Short press for 1S in the setting interface to confirm the setting.

Boot Animation Display

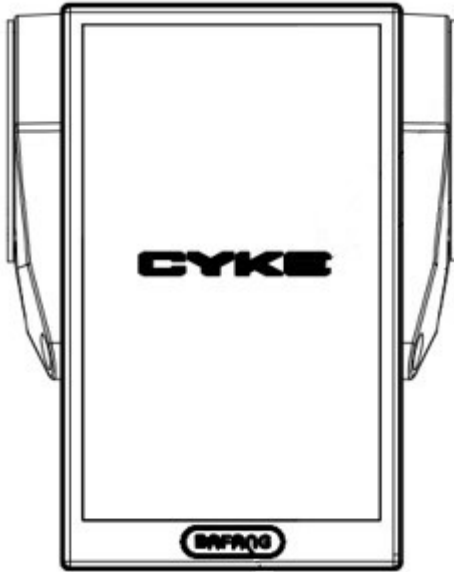

Power-Assisted Mode Selection

When HMI powers on, briefly press \wedge or \vee (<0.5S) to select the power-assisted mode and change the output power of motor. 4 Modes or 6 Modes can be selected, but the default selection is 6 Modes of which the lowest mode is ECO and the highest mode is BOOST. The default mode is OFF after HMI powering on, mode OFF means no power assistance.







6 Models



4 Models

Boost Mode Description

When in OFF gear, short press the  key to enter the boost mode, and the icon  will be displayed. Long press the  key again, the icon  will flash, and the vehicle will enter the boost mode. The vehicle boost speed is 4.4-6 km/H.



Multifunction Selection

Briefly press button  (<0.5S) to switch the different function and information. The position of multifunction indication displays the real-time clock (Clock) → single trip distance (TRIP, km) → total distance (ODO, km) → maximum speed (MAX, km/h) → average speed (AVG, km/h) → remaining distance (Range, km) → energy consumption (CAL, kcal) → riding cadence (Cadence, rpm) → riding time (Time, min) → cycle.

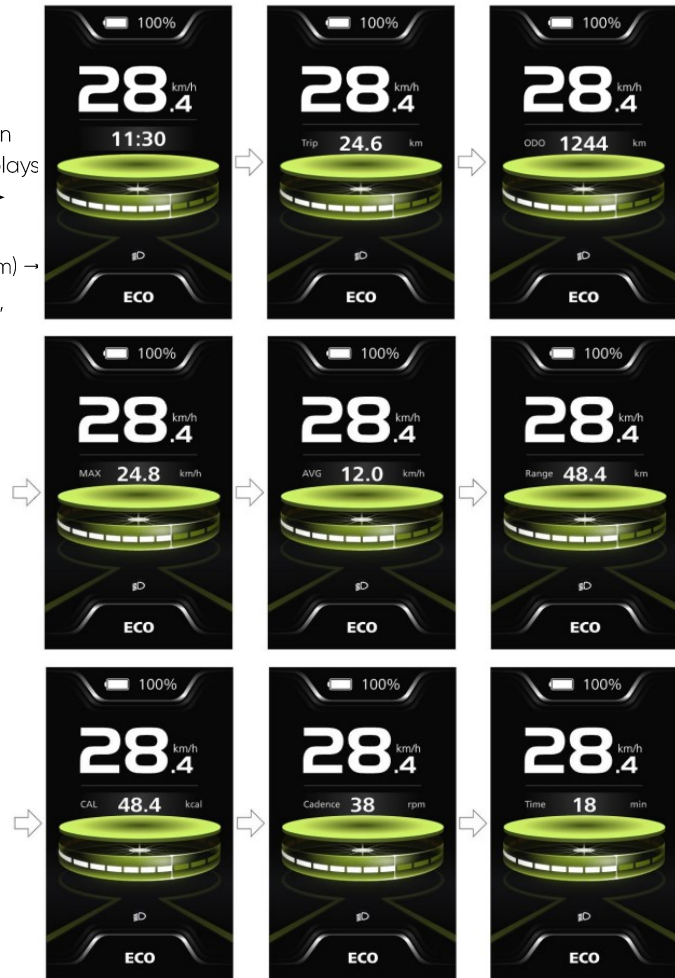

Battery Capacity Indication

HMI displays the real-time battery capacity from 100% to 0%. When the battery capacity is less than 5%, the indicator will blink at a frequency of 1 Hz to alert to recharge.

Bluetooth Function

This bicycle uses the Bluetooth system (provided according to the CYKE APP)

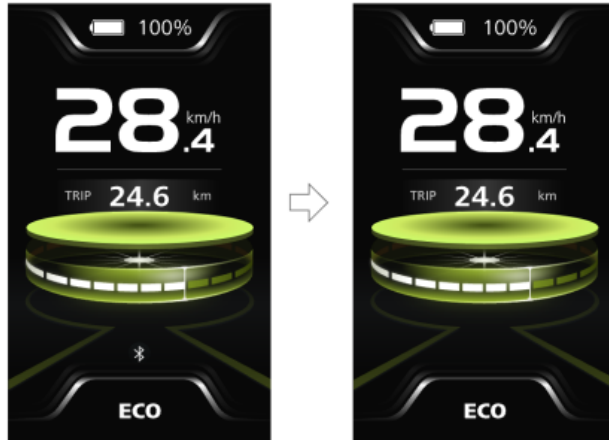

Bluetooth connection/disconnection interface

USB Charge Function

When the HMI is off, insert the USB cable into the charge port on the HMI, and then turn on the HMI to start charging. The maximum charge voltage is 5V and the maximum charge current is 1A.



USB charging/disconnecting charging interface

Data Summary Interface

Double-click  on the main interface to enter the data summary interface. The interface displays data as follows:

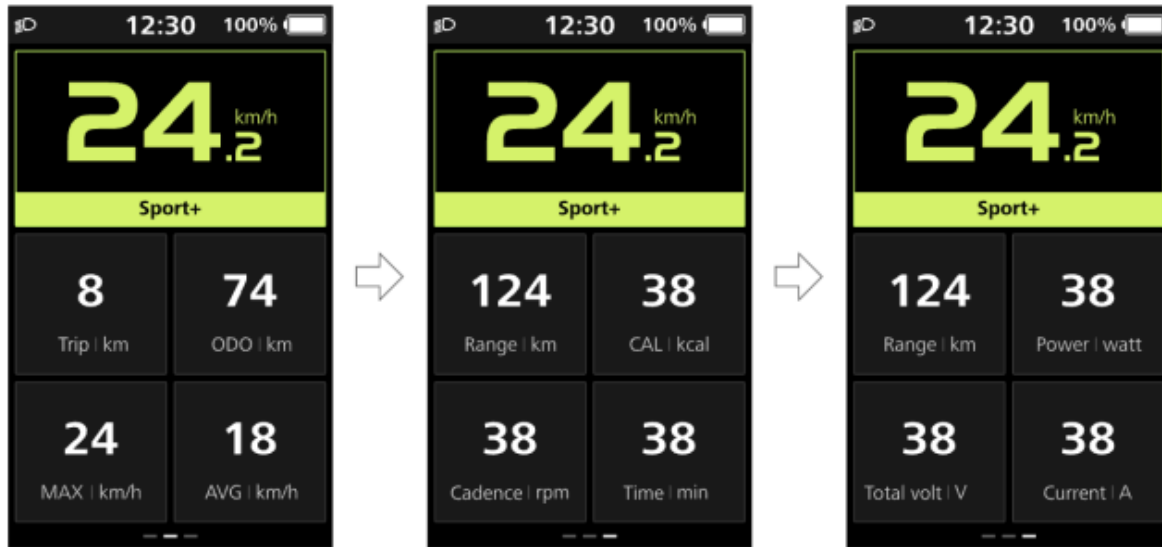

Data summary switching interface

Set Interface

“Quick settings” Interface

When in the main interface, press and hold the **▲** and **▼** buttons (at the same time) to enter the “Quick settings” interface. The settings are as follows:

1. Backlight brightness

After entering the interface, short press **▲** and **▼** to adjust the instrument backlight brightness. The adjustment range is 100%-10%. After setting, short press **⏻** to save.



2. “Auto off” Set automatic off time

After entering the interface, short press **▲** and **▼** to adjust the automatic shutdown time of the instrument, the adjustment range is OFF and 1-9min. the OFF state does not shut down; after the adjustment, short press **⏻** to complete the setting.

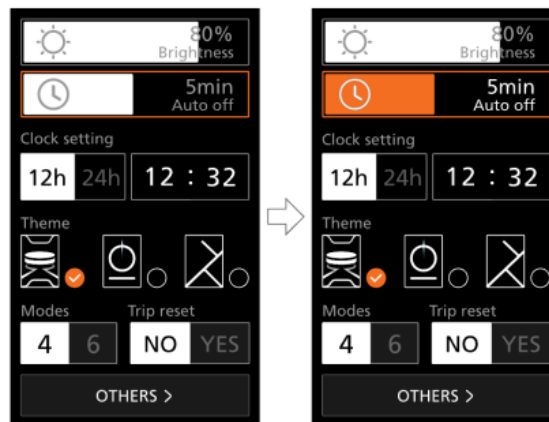

3. Clock setting

After entering the interface, short press **▲** and **▼** to adjust the instrument clock setting, which is divided into 12H system and 24H system. At the same time, the current time can be adjusted. After the adjustment is completed, click **⏻** to complete the setting.

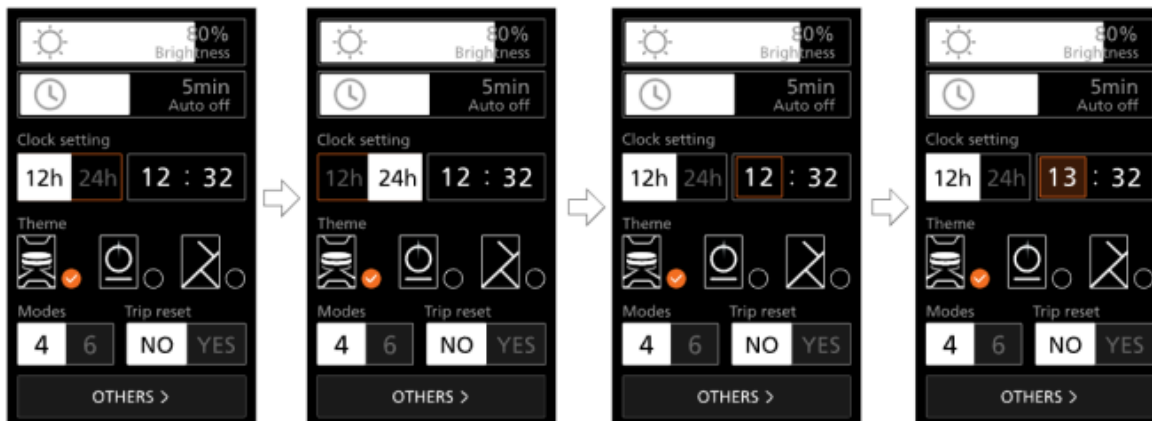

4. Main interface theme settings

In the quick settings interface, press **^** and **v**, and in the theme option, select the main interface theme



5. Overall mode settings

In the quick setting interface, press **^** and **v**, in the Modes option, you can switch the assist mode. You can choose between 4 Modes and 6 Modes. The factory default setting is 6 Model.

Instrument Parameter Setting Interface

1. Single mileage clearing

In the quick settings interface, press **^** and **v**, in the Trip reset option, select YES to clear the single trip mileage.

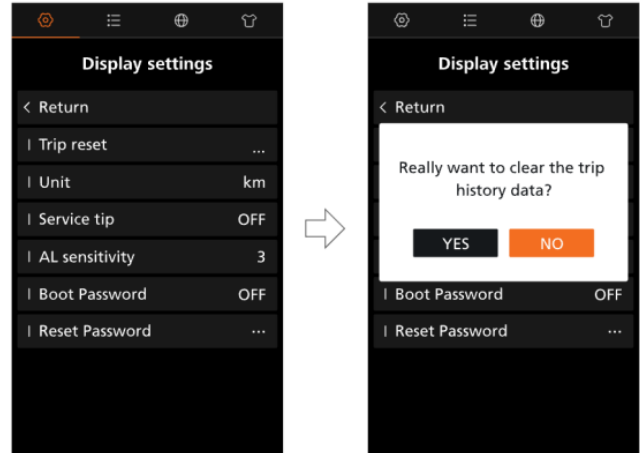

2. Unit conversion

Enter the Unit interface in the parameter setting interface to set the KM and Mile unit display.

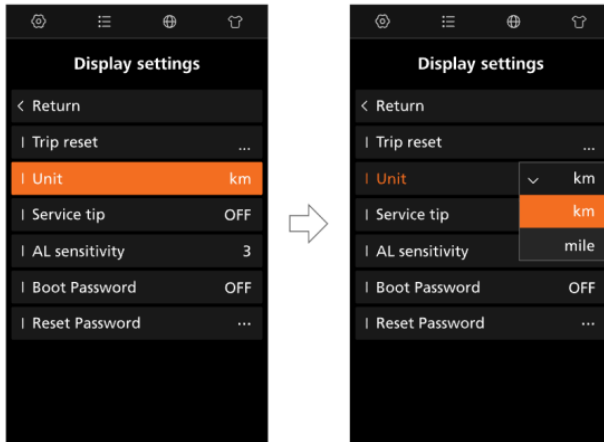

3. Maintenance tips

The Service tip option is a maintenance time prompt. You can set whether to turn on the maintenance prompt function. The maintenance prompt time is after the vehicle has ridden 5000KM. This option is OFF by factory default.

4. Light sensitivity

The light sensitivity can be set in the AI sensitivity option in the settings interface. Because the vehicle is not equipped with front and rear lights, this option function is turned off.

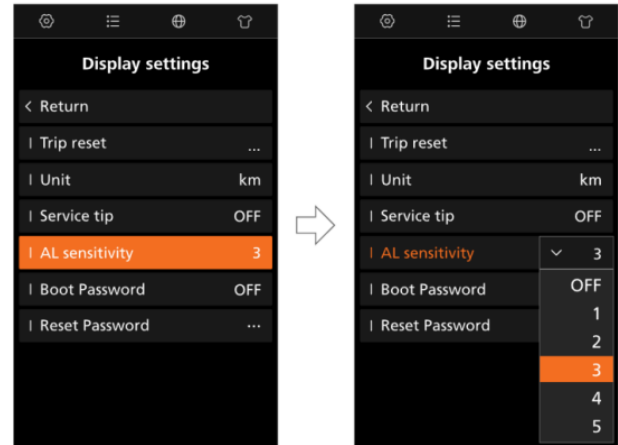

5. Password activation and setting

In the "Display settings" menu, select "Reset Password" by short-pressing the "Plus key" or "Minus key", short-press the "Power key" to enter the settings, and after entering the settings, short-press the "Plus key" or "Minus key" to select "0" ~ "9", short-press the "power button" to confirm, enter the 4-digit old password in sequence to confirm and then short-press "YES", then enter the 4-digit new password and short-press "YES", enter the 4-digit new password again to confirm. Short-press "YES" to successfully reset the password. Long-press the "Plus Key" & "Minus Key" to save and exit to the main interface. (Factory initial password is 0000) After the password is lost, it needs to be decrypted separately by the system BESST. (the vehicle electrical control express delivery will be decrypted at the designated after-sales maintenance point)

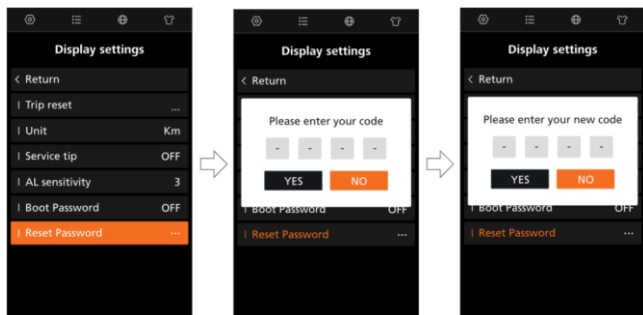

6. Reset password

In the "Display settings" menu, select "Reset Password" by short-pressing the "Plus key" or "Minus key", short-press the "Power key" to enter the settings, and after entering the settings, short-press the "Plus key" or "Minus key" to select "0" ~ "9", short-press the "power button" to confirm, enter the 4-digit old password in sequence to confirm and then short-press "YES", then enter the 4-digit new password and short-press "YES", enter the 4-digit new password again to confirm. Short-press "YES" to successfully reset the password. Long-press the "Plus Key" & "Minus Key" to save and exit to the main interface. (Factory initial password is 0000)

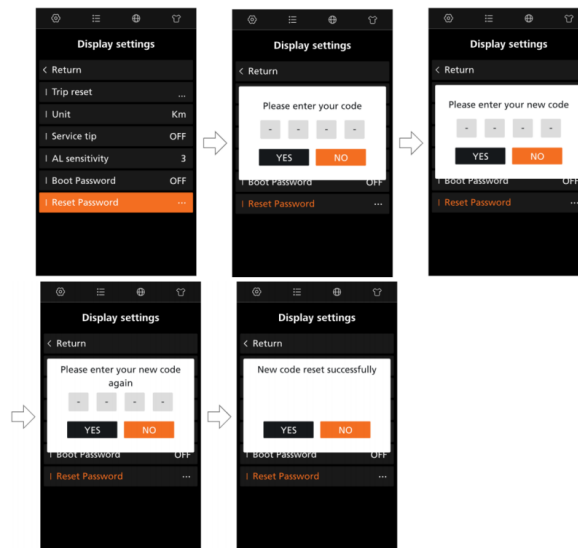

Information Viewing Interface

1. Wheel diameter and speed limit

The Wheel size interface in the Information interface can be used to set the entire wheel diameter. It is used after replacing the entire wheel diameter during modification. After setting, move the up and down keys of the instrument to "OK" and press  for confirmation.



2. Speed limit setting

The speed Limit interface in the Information interface can be used to modify the vehicle speed limit. The factory default is 20 miles. (CLASS2) It can be set to a maximum of 28 mph(CLASS3) here in this interface. (The handlebar is at the same speed as PAS)

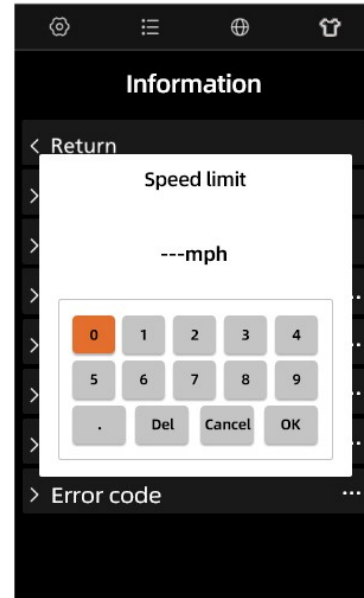

3. Other viewing interfaces

The remaining options are information viewing interfaces and cannot be changed. They are only for after-sales use.

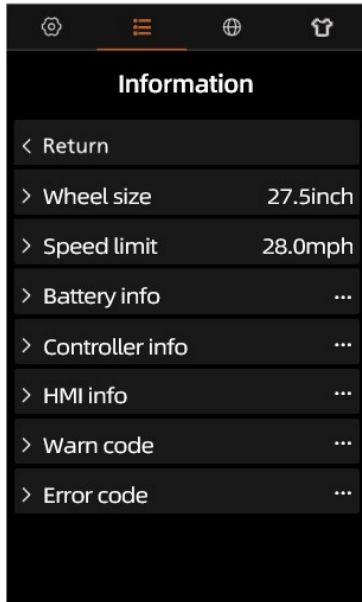

4. View battery information

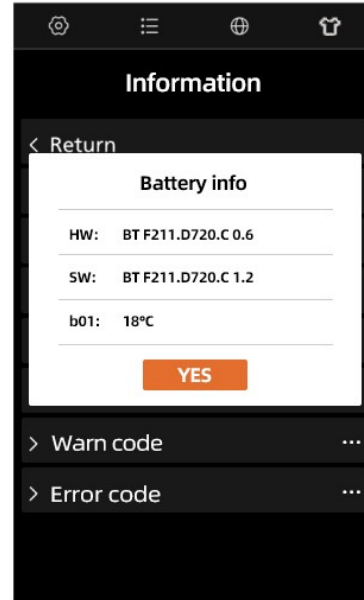

Battery version number and current battery temperature

5. System language settings

In the "Language" menu, select "English" by short pressing the "plus key" or "minus key"/"German" /"Nederlands" / "French" / "Italian" /"Czech" /, short press the "power key" to confirm the selection, long press the "plus key" & "minus key" to save and exit to the main interface.



6. Return interface

You can adjust the assist output ratio of PAS1-PAS5 in the interface below.

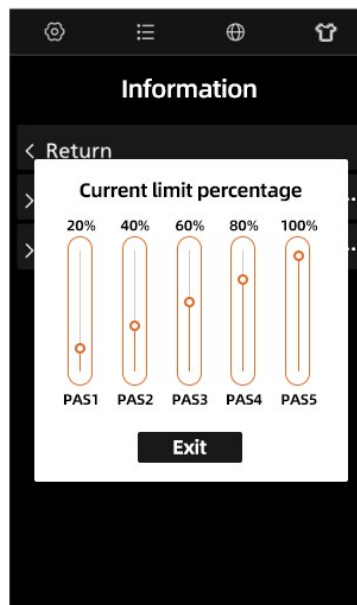

You can adjust the assist maximum speed of each PAS gear in the interface below.

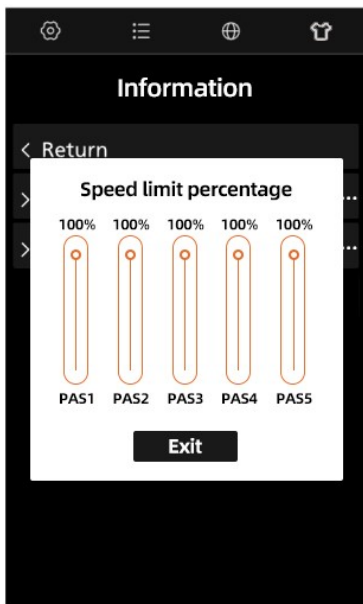

NOTICE: You can download CYKE Assistant to bind it with your e-bike, and quickly locate faulty modules through its Fault Test function.



WARNING! Now the whole bike is an electric power-assisted bicycle, so a motor is added to the original BIKE, thereby improving the power output of the whole bike and making riding more fun; but when climbing a steeper slope during riding, It is still recommended to place the flywheel above the second gear for use.

CYKE Assistant APP

The CYKE Assistant app is a software tool for the CYKE e-Bike. Connected with the CYKE e-bike via Bluetooth, it allows riders to track riding data, view e-bike info, and manage the e-bike easily, providing a superior and joyful ride.

Various Function Modules:

Virtual Dashboard - Control your e-Bike and master the riding data on the app

Hardware Management - Use the app for checking hardware info and managing e-Bike

Fault Detection - Use the app to detect faults, report errors, and guide repairs.

Battery Management - Equipped with BMS (Battery Management System) to meter battery info and status.

Information management - Register and manage user information through the app.

The CYKE Assistant app is a software tool for the CYKE e-Bike. Connected with the CYKE e-bike via Bluetooth, it allows riders to track riding data, view e-bike info, and manage the e-bike easily, providing a superior and joyful ride.

For IOS users, please search for CYKE Assistant on the APP Store or scan the QR code below to download



For Android users, please search for CYKE Assistant on Google Play or scan the QR code below to download



BATTERY AND CHARGER

As previously mentioned, your E-bike includes a powerful high-performance Lithium-ion battery which is assembled into the frame and is also removable. Be mindful of the energy stored in your battery and make sure you read and follow the below instructions regarding handling, charging, storing, and cleaning. Not following these instructions may have serious consequences and can result in a fire, which may seriously injure you and/or other people.

Battery Charging

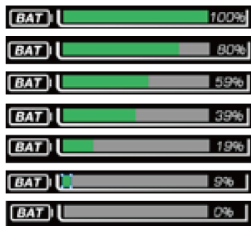

The power bar flashes when the battery level is 0

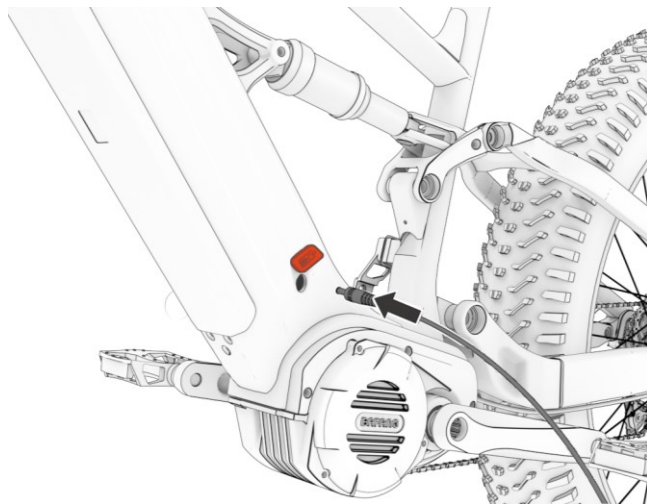

Open the charger cover. Insert the charger probe into the charger port. Make sure the connector is free from dirt, and debris, and dry before connecting the charger to the battery.



WARNING! You must plug the charger into the battery's charging port first before plugging the charger into the power outlet.

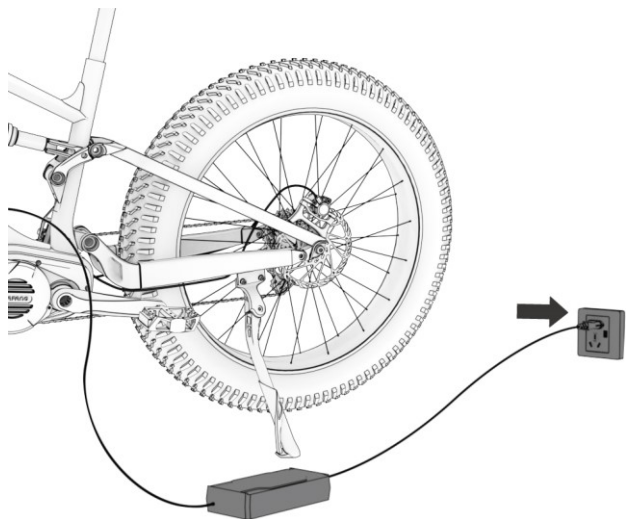

Insert the AC plug into an AC outlet. The red indicator light turns on and will remain red until the battery is fully charged. The indicator light turns green once the battery is fully charged.

When charging is complete, unplug the AC plug from the power outlet first, then disconnect the charging plug from the battery charging socket. Close and seal the charge port cover to seal it against water and debris.



The CYKE battery may be charged while on the bike or re-moved from the CYKE bike in a dry location for charging. Refer to the Battery Removal and Insertion for more instructions.



WARNING! Only use the battery charger that is provided with your CYKE bike to charge the battery. Connect the charging plug (110/240-volt plug) to the power outlet.

Battery Removal and Insertion



Insert the key and turn left to open the first lock. While holding the top of the battery with your hand, turn the safety lock in the direction of the arrow shown with the other hand.



NOTICE: Be sure to keep the keys supplied with your e-bike in a safe place, storing each separately is also suggested. If the keys are lost, the entire lock mechanism will need to be replaced.



As shown in the picture, carefully remove the battery.



CAUTION: Be careful not to drop the battery when removed from the bicycle. A hard enough impact can potentially damage the battery even if it may not be visible from the outside but can render the battery unsafe.

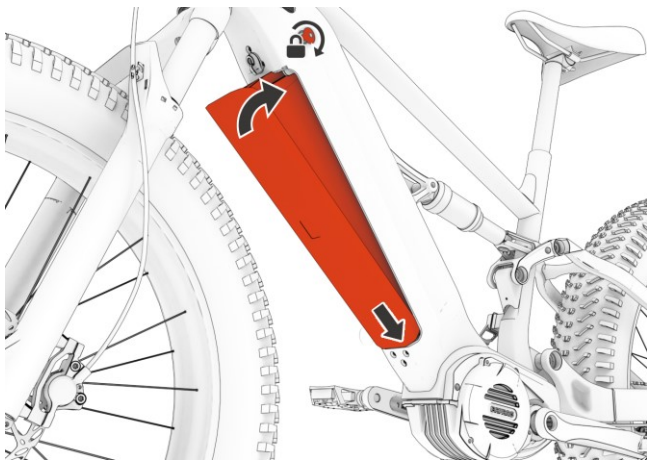

When installing the battery, first insert the low end of the battery into the internal slot in the bottom of the downtube smoothly. Then push the upper end of the battery into the downtube and turn the key to the right to lock it.

Operating Instructions



WARNING! Please read and familiarize yourself with the following Important Safety Instructions pertaining. Failure to adhere to these safety warnings can lead to severe injury or death.

Put the battery on a solid non-flammable surface when in use. The battery and charger should be laid flat on the surface so ports and plugs are horizontal, otherwise, the charge port and plug connecting to the socket may be damaged in other ways. To check the present Battery Capacity, turn on the display, and the information will be shown. Always unplug the battery and charger when not in use.

Connect the charger to the battery, and the indicator on the charger shows red light to indicate that the battery is charging. A completely discharged battery will need about 6-8 hours to be fully charged. After charging is complete, the indicator on the charger turns green. There is not any switch on the charger, so please disconnect the battery when it is completely charged. Do not push the bicycle pedals when the battery is charging on the bicycle, as it may damage the charge socket on the battery. The battery can be charged both on or removed from the e-bike but must not be moved during charging cycle.

Avoid using damaged, wet, or dirty power cable or socket as they may cause electric shock that can be a fatal injury.

When charging, ensure no flammable material is near the battery since it may generate heat.

Stop charging the battery immediately if it becomes too hot to touch, emits a strong odor, or has any other signs of overheating.

Do not charge the battery on a carpeted floor.

Do not cover the battery and charger during charging.

Use the battery charger provided with the product only. Applying the other charger which is not provided by the product may cause battery overheating and explosion.

Use a dry and undamaged power cable and charger only.

Replace a damaged power cable or charger immediately.

Before connecting a power cable, remove foreign matters at the charger port, such as dust, ice, and snow.

The battery and charger shall not be repaired. Do not try to disassemble or modify the battery or charger.

Do not use a battery with a damaged case.

Keep the battery away from children.

Do not put the battery in water.



WARNING! Check your bike as soon as possible after partial or complete submersion. Most likely its electrical system has been damaged and is unsafe to use. Carefully remove the battery pack from the bike and take it to a safe location OUTDOORS, away from flammable materials. To properly dispose of the battery, place it in a clear plastic bag and take it to your municipal household hazardous waste drop-off center. To find the closest facility in your area check with your local City Hall or Fire Department.



WARNING! UNDER NO CIRCUMSTANCES should you attempt to charge a battery pack that has been partially or totally submerged in water. Attempting to charge a compromised battery can result in a very dangerous fire that generates significant heat, toxic gasses and is extremely difficult to control.

Battery Storage

If the E-bike or the battery will not be used for a long time, comply with the following instructions during storage:

- Do not store the battery in an environment with temperatures below -20°C (-4°F) or above 45°C (113°F).
- Do not expose the battery to an environment with fluctuating temperatures. The ideal storage temperature range

is between 10°C (50°F) and 25°C (77°F).

- Store them in a dry environment to protect the battery against moisture to avoid the corrosion of electrical contacts.
- Do not store the battery near the flammable items.
- The battery will switch to offline in the following cases:
- E-bike has not been used for 2 months.
- The battery is completely depleted and/or is not charged for 2 months.

Please completely charge before returning battery and bike to normal use. Completely charge before returning battery and bike to normal use.



WARNING! Deep discharge of the battery may cause the internal short circuit. Heating the battery to very high temperature may cause fire. Avoid deep discharge during the use and storage of battery. When not in use, the battery shall be fully charged once every 2 months at least. Do not carry a deep-discharged battery on the E-bike.

MAINTENANCE

Basic Bike Care

To ensure safe riding conditions you must properly maintain your bike. Follow these basic guidelines and consult a certified bike mechanic at regular intervals to ensure your bike is safe for use and fun to ride.

Properly maintain batteries by fully charging them every two weeks or more often. Please check the Long-Term Battery Storage section for information about storing the battery for longer than two weeks before the next rides.

- Never immerse or submerge the bike or any components in water or liquid as the electrical system may be damaged.
- Periodically check wiring and connectors to ensure there is no damage and the connectors are secure.
- As for cleaning, wipe the frame with a damp cloth. If needed, apply a mild non-corrosive detergent mixture to the damp cloth and wipe the frame. Then wipe it with a clean, dry cloth.
- Store the e-bike under shelter and avoid leaving it in the rain or exposed to corrosive materials. If it's exposed to rain, dry your bike and apply anti-rust treatment to chain and other unpainted steel surfaces.
- Special care should be given to extend the life of your

bikewhen used in coastal areas or areas with salty air or water as riding there exposes your bike to salt, which is very corrosive. Wipe down your bike frequently and wipe or spray all unpainted parts with anti-rust treatment as damage from corrosion is not covered under warranty

- If the hub and bottom bracket bearings have been submerged in water or liquid, they should be taken out and re-greased. This will also prevent the bearing from accelerated deterioration.
- If the paint has become scratched or chipped off, use touch up paint to prevent rust. Clear nail polish can also be used as a preventative measure.
- Regularly clean and lubricate all moving parts, tighten components, and adjust them as required. Regularly inspect all pre-attached and optional component hardware to ensure proper torque spec, secure attachment, and good working condition.

Cleaning Your CYKE

Remove the battery pack from your bike first before cleaning the e-bike. Use a damp cloth with mild soap as needed to clean the outside of the battery. Do not insert anything into the electrical connector on battery for any reason as it should remain clean and dry when the bicycle is properly cared for.

The e-bike body can be cleaned with water from a garden hose, mild dish soap, and a damp cloth. But avoid spraying electronics

on the handlebars, electrical connectors, ends of the hub motor where axle protrudes, rear cassette, front sprocket and chain. Rinse the dish soap away thoroughly with low pressure water and thoroughly dry the bike while paying extra attention to remove any water from electrical components or connectors. A hair drier or a vacuum can also be used to remove water from places that are difficult to reach.

Reinstall the battery after the e-bike has been cleaned and thoroughly dried. Make sure the battery is properly installed and locked into the e-bike.



WARNING! Never immerse the bike or any of the components in water or other liquid. This can damage the electrical system and will void your warranty.



WARNING! Never clean the bike with high pressure jetted water as it can enter the electrical components and damage them.



WARNING! Always store the bike in a dry location. Thoroughly dry the bike after riding in the rain or washing it. For standing water can enter electronics or cause corrosion resulting in damage to the electrical system.

Tire Inflation and Replacement

Select proper-size tires according to the side wall of your e-bike tires. These tires use a rubber inner tube to retain air pressure. The tires on your e-bike are designed for cycling on typical terrains and surfaces. Please only replace the tires with a similar tire design of the same size. Always check all items related to Tires and Wheels listed in the Pre-Ride Check before each ride. Properly inflated tires will help ensure the maximum tire lifespan, the best bike performance, and the possible longest riding range.

Keep your tires inflated at 5–30 P.S.I. all the time. Never exceed the maximum pressure listed on the tire side wall. Tires will lose air pressure over time, so always check the tire pressure before operating the e-bike. Low tire pressure can result in damage to the wheels that will be more difficult and expensive to repair.

When replace the tires, always choose equivalent tires with reflective side walls. All the CYKE e-bikes are equipped from the factory with this type of tires to provide the most visibility of you and your bike in low light conditions. Keep the tires clean to ensure the reflective side wall can function properly.

Recommended Service Intervals

Regular inspection and maintenance are key to ensure the e-bike function and last as intended, and to reduce wear and tear on their systems. Recommended service intervals are only used as guidelines. Real world wear and tear, and the need for service, will vary with conditions of use. We generally recommend inspections, service, and necessary replacements to be performed at the time or mileage interval that comes in the following table.

Interval	Inspect	Service	Replace
Weekly 100-200 mi (160-321 km)	<ul style="list-style-type: none"> ● Check hardware for proper torque. ● Check drivetrain for proper alignment and well function (including the chain, freewheel, chainring, and derailleur). ● Check the wheel for trueness and quiet operation (without spoke noise). ● Check the condition of frame for any damage. 	<ul style="list-style-type: none"> ● Clean the frame by wiping frame down with a damp cloth. ● Use barrel adjuster(s) to tension derailleur/brake cables if needed. 	<ul style="list-style-type: none"> ● Replace any components damaged beyond repair or broken after confirming with CYKE Product Support or a certified bike mechanic.
Monthly, 250-750 mi (402-1207 km)	<ul style="list-style-type: none"> ● Check the brake for pad alignment and cable tension. ● Check the e-bike for proper shifting and derailleur cable tension. ● Check the chain stretch. ● Check the brake and shifter cables for corrosion or fraying. ● Check the spoke tension. ● Check the accessory for mounting and alignment (rack mounting bolts, fender hardwares). 	<ul style="list-style-type: none"> ● Clean and lubricate the drivetrain. ● Check the crankset and pedal torque. ● Clean brakes and shift cables. ● True and tension the wheels if any loose spokes are discovered. ● Balance the battery. 	<ul style="list-style-type: none"> ● Replace brake and shift cables if necessary. ● Replace brake pads if necessary.
Every 6 Months, 750-1250 mi (1207- 2011km)	<ul style="list-style-type: none"> ● Inspect the drivetrain (chain, chainring, freewheel, and derailleur). ● Inspect all cables and housings. 	<ul style="list-style-type: none"> ● Receive standard tune-up by a certified, reputable bike mechanic. ● Grease the bottom bracket. 	<ul style="list-style-type: none"> ● Replace brake pads. ● Replace tires if necessary. ● Replace cables and housings if necessary.

Troubleshooting

Symptoms	Possible Cause	Most Common Solution
E-Bike does not work	<ul style="list-style-type: none"> ● Battery Deplete/Very Low battery level ● Faulty connections ● Battery not fully seated in the connector ● Improper turn on ● Blown Fuse in the battery ● Brakes applied or stuck 	<ul style="list-style-type: none"> ● Charge the battery ● Clean or repair the connector ● Reinstall battery and ensure it is completely seated ● Review the manual, follow the right start procedure ● Replace with the new fuse on the same size ● Disengage/free the brakes
Reduced Range	<ul style="list-style-type: none"> ● Low tire pressure ● A ow or faulty battery ● Riding with too many hills, excessive load, headwind, applying brakes while riding. ● Battery was left discharged for a long period of time without regular charging, aged, damaged, or with voltage unbalance. ● Brakes adjusted improperly 	<ul style="list-style-type: none"> ● Adjust the tire pressure ● Check connections and fully charge the battery ● Assist the e-bike with proper pedal effort, change the route, reduce load on the e-bike, and balance the battery voltage. ● Contact Customer Service or Authorized Service shop if the reduced range persists. ● Adjust the brakes to eliminate drag when brake levers are not pulled, ensure calipers and/or pads can move freely.
Irregular acceleration and/or reduced top speed	<ul style="list-style-type: none"> ● Insufficient battery power ● Loose or damaged throttle/ PAS controller ● Damaged torque sensor in the bottom bracket 	<ul style="list-style-type: none"> ● Charge or replace the battery ● Replace the Throttle/PAS controller ● Contact Authorized Service shop for repair
Motor does not respond when e-bike is powered on	<ul style="list-style-type: none"> ● Loose or damaged wiring connection ● Loose or damaged throttle/PAS control ● Loose or damaged motor wires/plug ● Damaged motor 	<ul style="list-style-type: none"> ● Repair and/or reconnect wiring ● Tighten or replace the throttle/PAS control ● Secure, repair, or replace the damaged wires/plug ● Contact Authorized Service shop to replace the motor
Battery does not charge	<ul style="list-style-type: none"> ● Charger not connected well/completely ● Charger damaged ● Battery damaged ● Wiring damaged ● Blown Fuse in the battery 	<ul style="list-style-type: none"> ● Adjust the connections of the charger ● Replace the charger ● Replace the battery ● Repair or replace the wiring ● Reset circuit breaker or replace the fuse
Wheel or motor makes strange noises	<ul style="list-style-type: none"> ● Loose or damaged wheel spokes or rim ● Loose or damaged motor wiring ● Debris interfering with wheels 	<ul style="list-style-type: none"> ● Tighten, repair, or replace the wheel spokes or rim ● Reconnect or replace the motor wiring ● Remove debris and inspect for damage

WARRANTY POLICY

Length of Warranty

Every bicycle has a useful product lifespan. This limited warranty is not meant to suggest or imply that the frame or components can never be broken or will last forever. This limited warranty covers manufacturing defects that occur within the normal lifespan and use of the product.

For CYKE bikes, the serial number is the singular certificate for after-sales (warranty).

Before purchasing, please check the serial number in detail. In case of a worn serial number, please do not purchase the E-bike.

The electric bicycle serial number is noted on the Master Carton and the bottom tube of the frame. The battery serial number is noted on the battery pack.

Warranty Conditions

This limited warranty applies only to the original owner of the bicycle and is not transferable to subsequent owners or other transferees of the electric bicycle. Only the original owner of an electric bicycle purchased from CYKE online or CYKE authorized distributor or retailer is covered by Limited Warranty. The Warranty Period begins upon your receipt of the electric bicycle

and shall end immediately when any sale or transfer of the electric bicycle is made, and under no circumstances shall the Limited Warranty apply to any subsequent owner or other transfer of the electric bicycle.

- Bike Frame: 5-year warranty
- All other mechanical components: 1-year warranty
- Electrical components: 2-year warranty

For any warranty claim to be considered, the E-bike must be in an assembled, reasonably clean and sanitary condition and accompanied by the original, dated sales receipt for the bicycle (be sure to keep your receipt in a safe place!).

This limited warranty is void if the bicycle is subjected to abuse, neglect, improper repair, improper assembly, lack of proper maintenance according to the owner's manual, alteration, modification, installation of incompatible parts, corrosion, an accident or other abnormal, excessive, or improper use. This limited warranty is void if the bicycle is used in a rental or bike sharing program.

Damage resulting from normal wear and tear, including the results of fatigue, is not covered. It is the owner's responsibility to regularly inspect and properly maintain his/her bicycle. Some items that typically exhibit damage from normal wear and tear include:

- Bearings
- Bearing Races
- Chain Rings
- Cassettes
- Tires
- Tubes
- Saddles
- Chain
- Brake Pads
- Brake Disks
- Wheel Hubs
- Spokes
- Handlebar Grips
- Cables and Housing
- Bushings

Damage to a Covered Component during shipping is not covered by this Limited Warranty, but CYKE will replace such damaged Covered Components if you:

- Notify CYKE of a Covered Component damaged in the shipping process within thirty (30) days of your receipt of the electric bicycle;
- Provide CYKE with a dated picture of the damaged Covered Component;
- Return all original packaging and paperwork included with the electric bicycle;
- Note any immediately recognizable damage on the

shipper's Bill of Lading prior to signing off on the shipment. Shipping damage claims are very time sensitive and it is your responsibility to immediately inspect the electric bicycle for damage upon receipt.

Paint fading caused by the effects of ultraviolet light (UV) or outdoor exposure is not covered by this limited warranty. All labor charges for warranty service, including the transfer of components and/or any installation of new components, are the responsibility of the bicycle owner.

Due to product evolution and obsolescence (such as products that have been discontinued or are no longer kept in stock), some frames or components may not be available for older or limited edition models. In these cases, CYKE may elect to provide a replacement that it determines to be the most nearly comparable model, but sourcing and paying for components is the responsibility of the bicycle owner.

All determinations under this limited warranty will be made in the sole discretion of CYKE, including but not limited to the decision to repair or replace a defective product, and what replacement product is the most nearly comparable product then available.

The remedies stated above are the exclusive remedies under this warranty. Any and all other remedies and damages that may otherwise be applicable are excluded, including, but not limited

to, incidental or consequential damages, damages to other property, or any punitive damages.

This is the only warranty made by CYKE on its frames and components, and there are no warranties which extend beyond the description herein. Any warranties that may otherwise be implied by law including, but not limited to, any implied warranty of merchantability or fitness for a particular purpose, are excluded.

Please refer to the documents included with your bicycle for possible further restrictions.

This limited warranty gives the consumer specific legal rights. The consumer may also have other legal rights which vary from state to state or country to country. Some states and countries do not allow the exclusion or limitation of incidental or consequential damages or warranties, so the above limitations or exclusions may not apply to you. If it is determined by a court of competent jurisdiction that a certain provision of this limited warranty does not apply, such determination shall not affect any other provision of this limited warranty and all other provisions shall remain in effect.

CYKE

cykebikes.com

VERSION: V1.0

**READ THESE INSTRUCTIONS CAREFULLY
BEFORE FIRST USE AND KEEP THEM FOR
FUTURE REFERENCE.**

SUPPORT

 (888) 778-6789

 support@cykebikes.com