

REVISION		DATE	BY	APPROVED
REV	DESCRIPTION			
B				

BRUSH DIMENSION

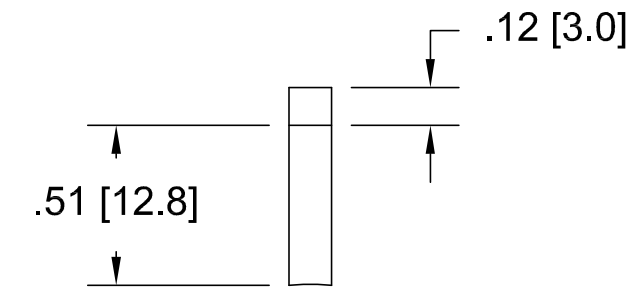

BRUSH ASSEMBLY

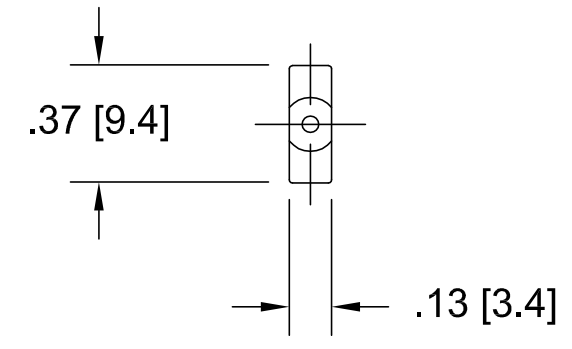
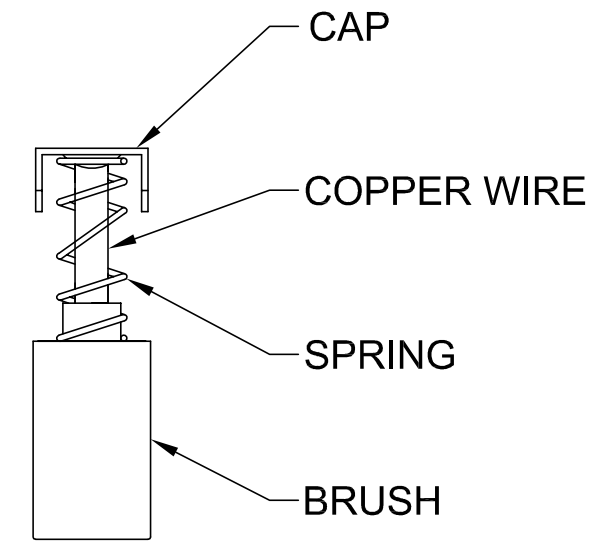
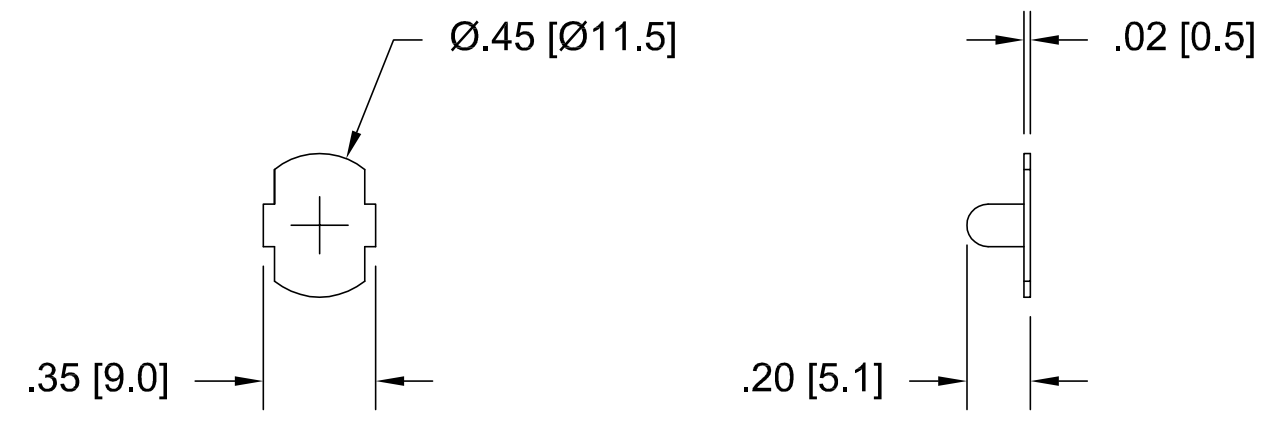

- NOTES:**
- 1.) BRUSH MATERIAL: B371
 - 2.) CAP MATERIAL: Cu

UNLESS OTHERWISE SPECIFIED DIMENSIONS ARE IN INCHES & [mm]	 THIRD ANGLE PROJECTION DO NOT SCALE DRAWING	THE INFORMATION CONTAINED IN THIS DRAWING IS THE SOLE PROPERTY OF MAGMOTOR TECHNOLOGIES. ANY REPRODUCTION OR DISCLOSURE OF THE INFORMATION CONTAINED THEREIN IN PART OR AS A WHOLE WITHOUT THE WRITTEN PERMISSION FROM MAGMOTOR TECHNOLOGIES IS PROHIBITED.		
		SIGNATURES	DATE	
TOLERANCES ON: ANGLES = ± 1/2° X.XX [X.X] = ± .01 [0.25] X.XXX [X.XX] = ± .005 [0.12]	125 ✓			BRUSH, S28, POWER ENDBELL, .13" x .37" x .50" LG, MATERIAL: B371
MATERIAL	DRAWN SLC	12/2/2019		
SPEC -	CHECKED			
FINISH -	ENG APPR.			
SPEC -	MFG APPR.			
	Q.A.			
	UNLESS OTHERWISE SPECIFIED REMOVE ALL BURRS & SHARP EDGES. COUNTERSINK TAPPED HOLES TO BODY SIZE FILLETS: .03 MAX. / EXTERNAL CORNERS: .015 MAX.			
	SCALE: NONE	WEIGHT: -	SHEET 1 OF 1	REV B