



National Murphy Beds

Version SL01.23FLEX

INSTALLATION INSTRUCTIONS – HORIZONTAL BEDS (WOOD)–

These instructions do not apply to Vertical murphy beds.

BEFORE YOU BEGIN, PLEASE TAKE A FEW MOMENTS TO FAMILIARIZE YOURSELF WITH ALL OF THE PARTS AND CONFIRM THAT ALL OF THE HARDWARE IS INCLUDED. NATIONAL CASEGOODS IS NOT RESPONSIBLE FOR LOSS OF TIME OR HIRED LABOR DUE TO MISSING PARTS. ALSO, READ THESE INSTRUCTIONS THOROUGHLY BEFORE STARTING THE ASSEMBLY AND INSTALLATION.

WARNING

**FAILURE TO PROPERLY SECURE THE BED TO THE WALL
CAN CAUSE SERIOUS INJURY! READ ALL SAFETY
INSTRUCTIONS BEFORE INSTALLATION.**

ASSEMBLY AND INSTALLATION REQUIRES TWO PEOPLE!

You will need to have these tools to install the Murphy bed:



Drill



**Phillips
Screwdriver**



**Stud
Finder**



**1/8" Wood or
5/32" Masonry Drill Bit
(per wall type)**













**Square
Drill Bit
(6" #2)**

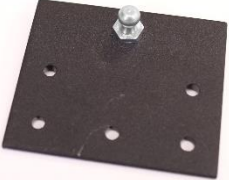



Ladder

HARDWARE INCLUDED

– (Additional hardware/screws are included for beds with side cabinets and/or lighting kits)

Part	QTY.	Description	Color	Picture (not actual sizes)
A	2	Piston	Black	
B	2	Cabinet Vertical Plate	Black	
C	2	Assembled Face Plate	Black	
D	2	Pivot Pin Plate	Black	
E	2	Pivot Hole Plate	Black	
F	18	3/4" T-Nut	Black	
G	18	5/8" Machine Screw	Silver	
H	28	3/4" Wood Screw	Black	
I	2	Bed Stopper	Black	
J	2	E-Clip	Black	 
K	2	Thick Nylon Washer	White	

L	14	3/4" Cam Dowel	Silver	
M	4	1 1/2" Pocket Screw	Silver	
O	4	3" Wood Screw	Black	
P	2	Swing Leg	Black	
Q	2	Swing Leg Plate	Black	
R	2	1 1/2" Flat Head Cap Screw	Black	
S	4	Thin Nylon Washer	Black	
T	2	Lock Nut for Swing Leg	Silver	
U	1	3/16" Allen Wrench	Black	
V	1	1/2" Wrench	Silver	



IMPORTANT SAFETY INFORMATION!



- It is extremely important that the bed be properly and securely affixed to the wall. Failure to do so can cause serious injury or death.
- The Murphy bed should be securely fastened to wall studs, concrete, block, brick or other wall type using the proper fasteners.
- When affixing the header to wall studs, the fasteners should be inserted into the center of the wall stud.
- The proper tools need to be utilized in installation of the bed. These are listed in the Installation Instructions.
- Installation of the bed should be performed by two people. Attempting to install the bed alone can cause injury.
- The Murphy bed should sit flush against the wall for secure installation.
- Never attempt to unscrew the Murphy bed from the wall while it is open.
- If you are using lighting, you should keep covers, comforters, and other bedding away from the bed when you close the bed. You should tuck any bulky bedding tightly between the mattress and the frame rails of the Murphy bed. Also, make sure no wires are being pinched at any location.
- Walls other than Wood Stud walls will require alternate fasteners (not provided) for installation. These may include molly/hollow wall anchors, toggle bolts (suggested for metal stud walls), Tapcons®, or other fastener types. Please consult the local home improvement store for recommendations.

HELPFUL HINTS:

1. Unless you requested to have the Murphy bed without a notch for the base molding at the bottom of the wall, a 5 inch tall by 1 inch notch is included on the Murphy bed Cabinet Verticals. This is necessary for the Murphy bed to sit flush against the wall for a secure installation. If you ordered the Murphy bed without a notch because you want to make a different size notch, you should do this first, BEFORE any other step.
2. Unless you ordered the Murphy bed with extra depth, it is built to accommodate any standard innerspring mattress up to 12 inches in total thickness.

PLACING PARTS ON THE ASSEMBLED FACE

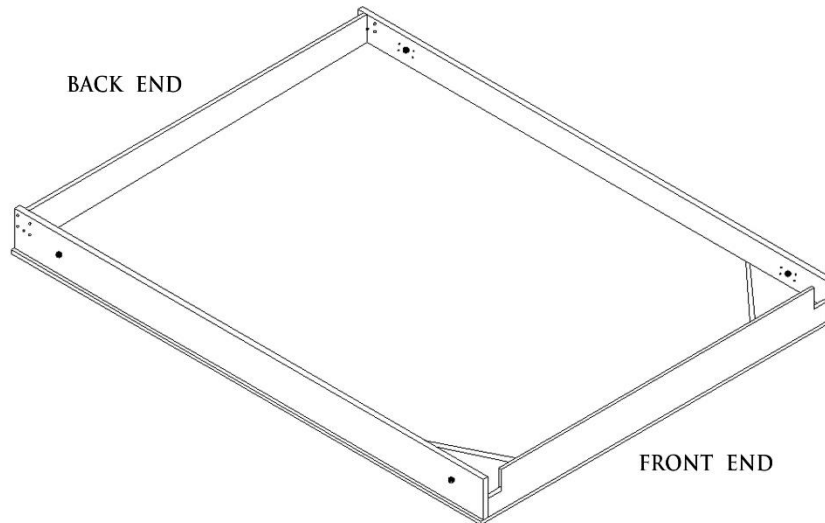

The Assembled Face has been precisely machined for the parts you will need to install. Based on the machined holes in the side rails of the Assembled Face, you can easily determine the location of the parts/plates to be installed. The diagram above indicates the front end and back end of the Assembled Face. Notice that the front end will have elastic straps at each corner for securing the mattress in place. It also will have two notches to allow the Swing Leg (●) to be moved to the down position. If you are assembling the Murphy bed on hard flooring surfaces (tile, hardwood, etc.), make sure to place the Assembled Face on a protective material to avoid scratching the decorative façade.

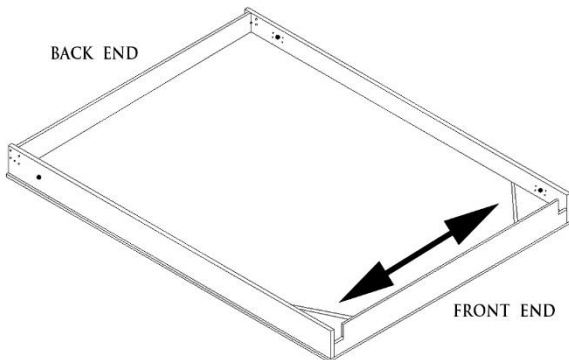

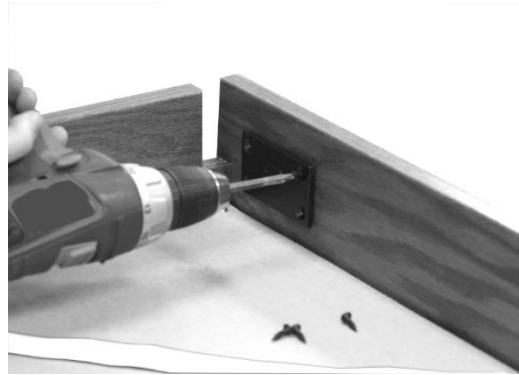
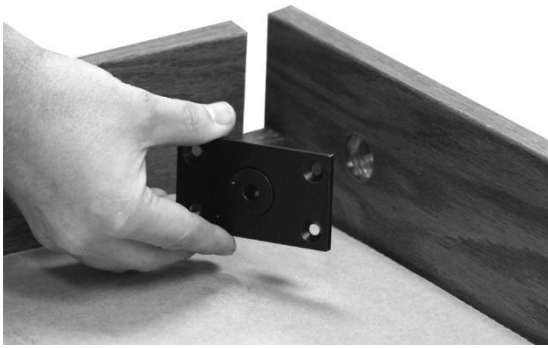

Position one Swing Leg Plate (**P**) at the front end of the Assembled Face, and from the inside, insert the 1" tube into the 1" hole. Insert four ¾" Wood Screws (**H**) in the four pre-marked holes on the inside of the Assembled Face. REPEAT THIS STEP ON THE OTHER SIDE OF THE ASSEMBLED FACE.

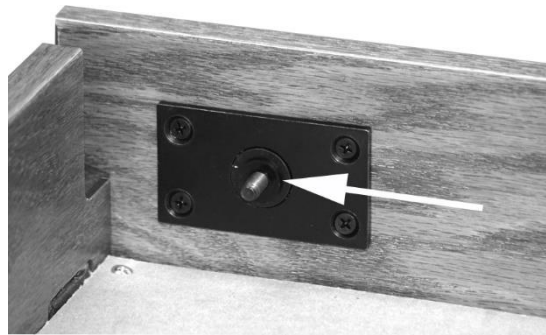

From the outside of the Assembled Face, push one 1½" Flat Head Cap Screw (**Q**) through the Swing Leg Plate (**P**). Next, place one Thin, Black Nylon Washer (**R**) on the 1½" Flat Head Cap Screw (**Q**), on the inside of the Assembled Face. REPEAT THIS STEP ON THE OTHER SIDE OF THE ASSEMBLED FACE.

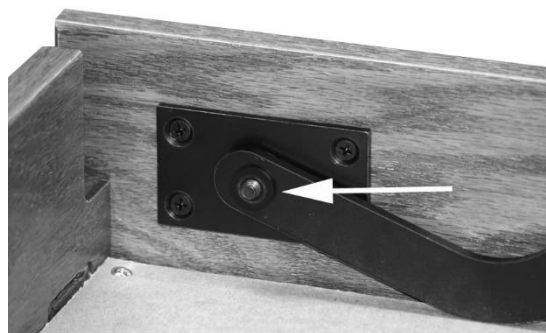

Using the picture above as a guide, place one Swing Leg (**O**) on the inside of the Assembled Face, pushing it onto the 1½" Flat Head Cap Screw (**Q**). Next, place one Thin, Black Nylon Washer (**R**) on the 1½" Flat Head Cap Screw (**Q**).

There should be a Thin, Black Nylon Washer (**R**) on both sides of the Swing Leg (**O**) inside of the Assembled Face. REPEAT THIS STEP ON THE OTHER SIDE OF THE ASSEMBLED FACE.

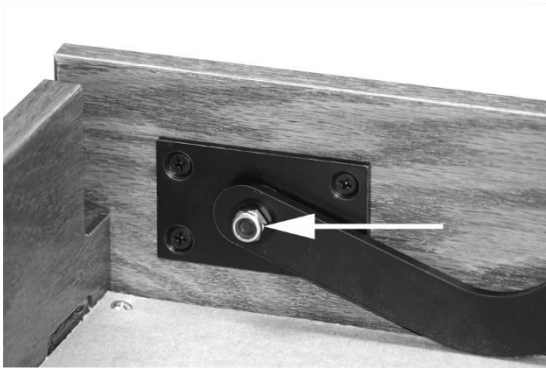

Thread a Locknut (**S**) onto the 1½" Flat Head Cap Screw (**Q**). The ½" Wrench (**U**) that is included will be used to tighten the Locknut (**S**) to secure the Swing Leg (**O**). REPEAT THIS STEP ON THE OTHER SIDE OF THE ASSEMBLED FACE.

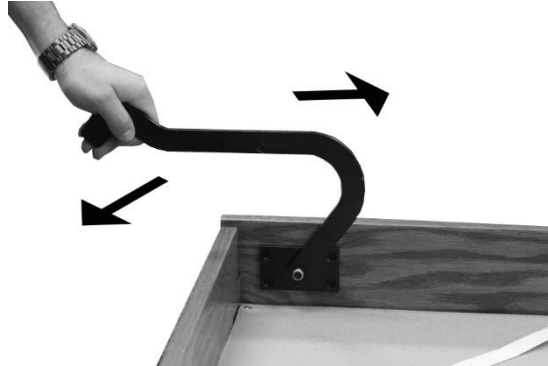

Using the included Allen Wrench (**T**) and the ½" Wrench (**U**), tighten the Locknut (**S**) onto the 1½" Flat Head Cap Screw (**Q**), but be sure to not over-tighten the Locknut (**S**) as this will make the Swing Leg (**O**) harder to operate. If you feel that you have over-tightened the Locknut (**S**), simply loosen it very slightly until the Swing Leg (**O**) moves freely up and down. The Locknut (**S**) will stay engaged and not come off of the 1½" Flat Head Cap Screw (**Q**), but the Swing Leg (**O**) will move more easily. REPEAT THIS STEP ON THE OTHER SIDE OF THE ASSEMBLED FACE.

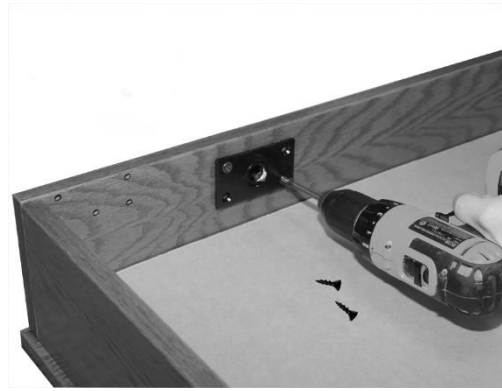
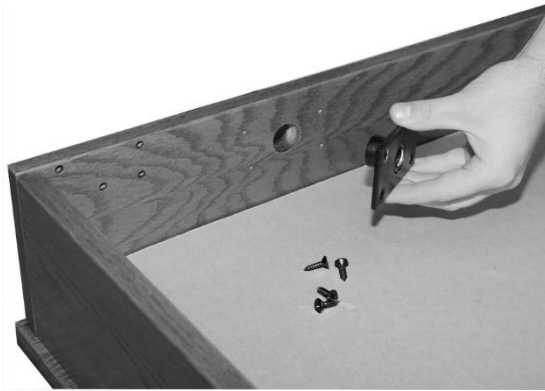
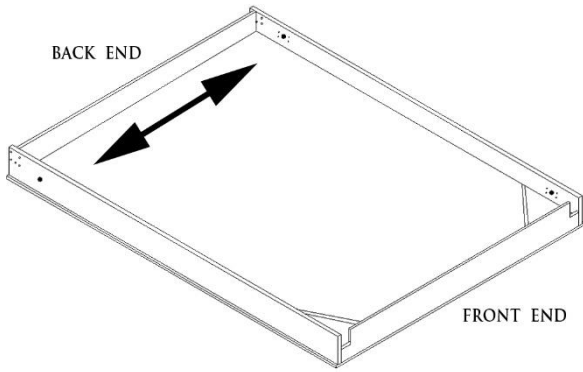

Position one Pivot Hole Plate (**E**) at the back end of the Assembled Face, and from the inside, insert the 1" tube into the 1" hole. Using the pre-marked hole locations as a guide, secure the Pivot Hole Plate (**E**) with four $\frac{3}{4}$ " Wood Screws (**H**) on the inside of the Assembled Face. REPEAT THIS STEP ON THE OTHER SIDE OF THE ASSEMBLED FACE.

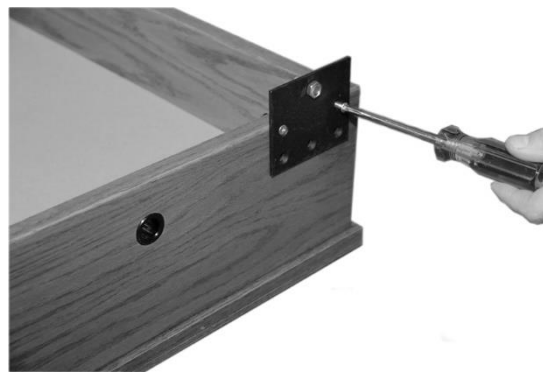
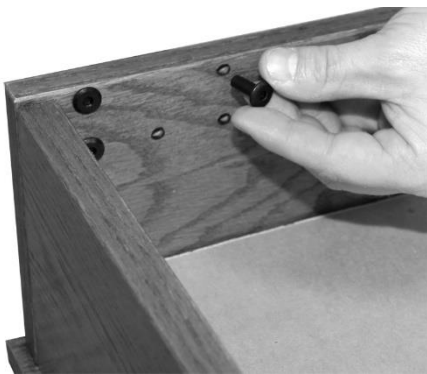

At the back end of the Assembled Face, insert five $\frac{3}{4}$ " T-Nuts (**F**) in the five through holes from the inside as shown above. Then, insert a $\frac{5}{8}$ " Machine Screw (**G**) in all five holes, through the Assembled Face Plate (**C**) and thread them into the five $\frac{3}{4}$ " T-Nuts (**F**). Tighten these five $\frac{5}{8}$ " Machine Screws (**G**) using a Phillips screwdriver. REPEAT THIS STEP ON THE OTHER SIDE OF THE ASSEMBLED FACE.

PLACING PARTS ON THE CABINET VERTICALS

The Cabinet Verticals are precisely machined for the parts you are about to install. Based on the machined holes in the Cabinet Verticals, you can easily determine the location of the plates. The diagram also indicates the direction and position of these parts, as well as the proper fastener to use for each.

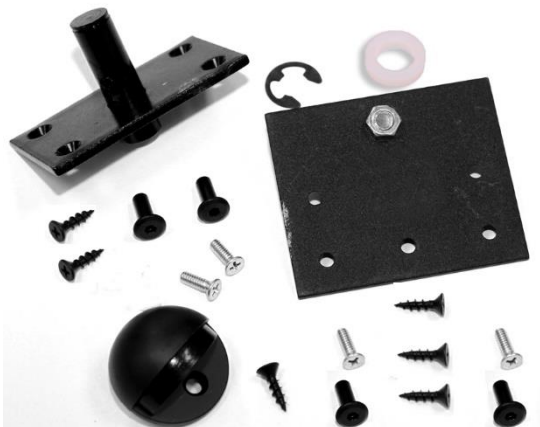
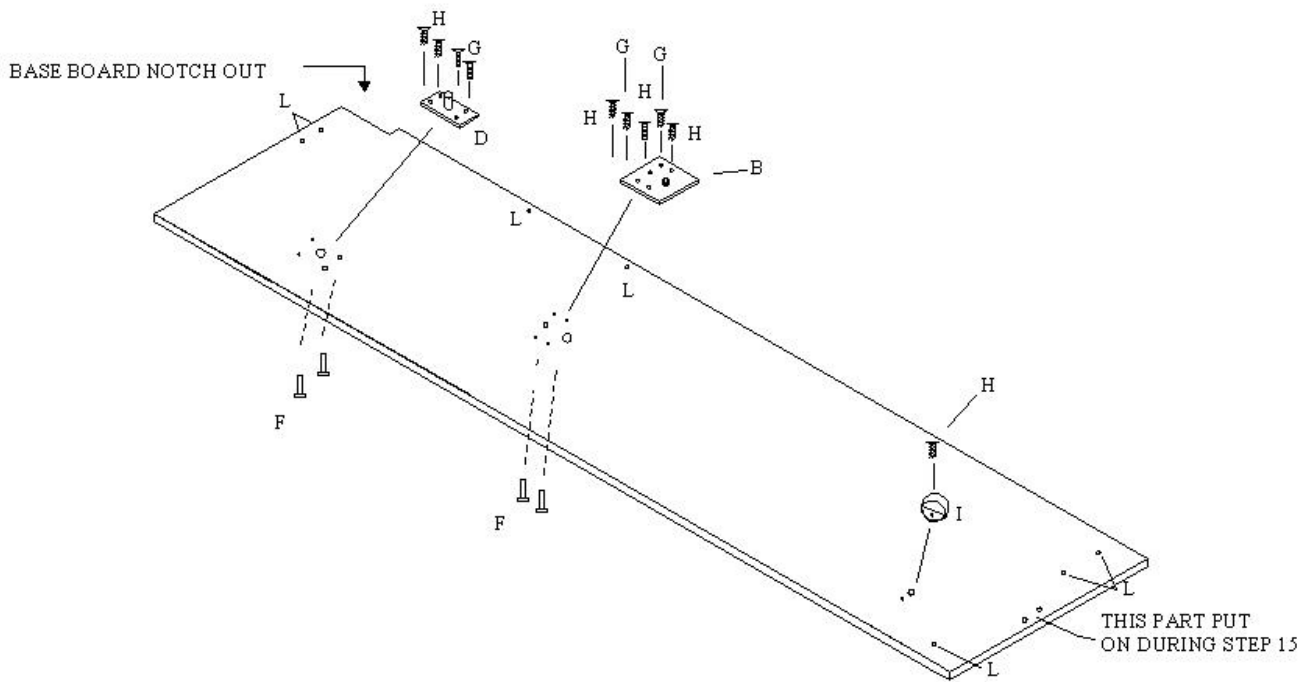

(Back side of Cabinet Vertical shown)

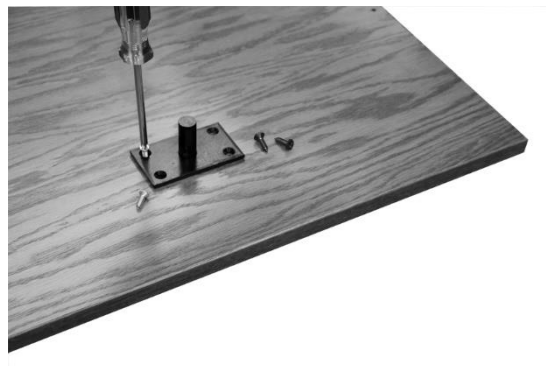

With one Cabinet Vertical lying on its side and several holes facing up, position one Pivot Pin Plate (**D**) with the 1/2" end of the rod inserted into the lower most 3/4" hole. Insert two 3/4" T-Nuts (**F**) in the two through holes from the "back side" of the Cabinet Vertical. Insert a 5/8" Machine Screw (**G**) through the Pivot Pin Plate (**D**) and thread into each of the 3/4" T-Nuts (**F**). Finish by inserting two 3/4" Wood Screws (**H**) in the remaining holes. The pre-marked holes ease this installation. REPEAT THIS STEP FOR THE REMAINING CABINET VERTICAL.

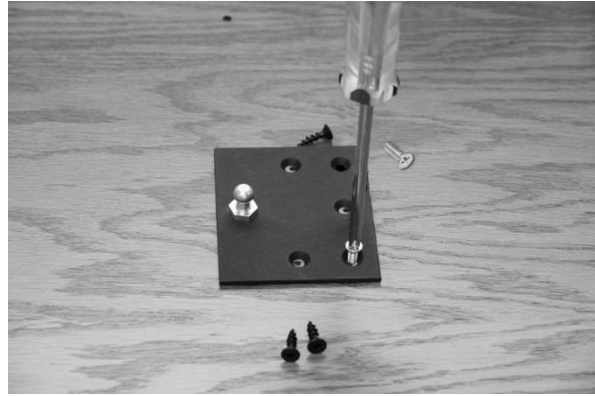
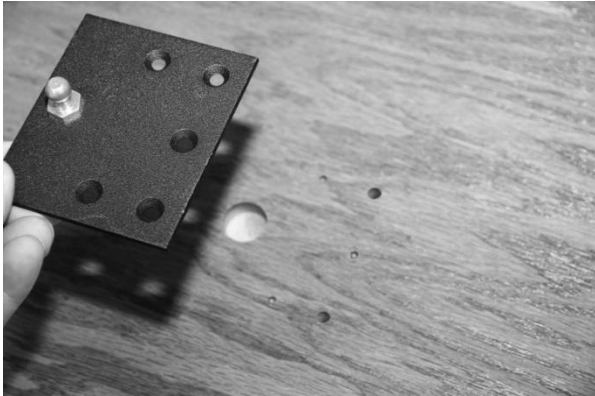

Position one Cabinet Vertical Plate (**B**) with the nut on the back of this plate inserted into the upper most 3/4" hole. Insert two 3/4" T-Nuts (**F**) in the through hole from the back side of the Cabinet Vertical. Insert two 5/8" Machine Screws (**G**) through the Cabinet Vertical Plate (**B**) and thread it into the 3/4" T-Nuts (**F**). Finish by inserting three 3/4" Wood Screws (**H**) in the remaining holes, using the pre-marked hole locations. REPEAT THIS STEP FOR THE REMAINING CABINET VERTICAL.



Position one Bed Stopper (**I**) with the pin on the back inserted into the $\frac{1}{4}$ " hole near the top. Position the Bed Stopper (**I**) as to line up its hole with the pre-marked hole on the Cabinet Vertical. Secure this with a $\frac{3}{4}$ " Wood Screw (**H**). REPEAT THIS STEP FOR THE REMAINING CABINET VERTICAL.



In the seven (**7**) remaining holes, screw a $\frac{3}{4}$ " Cam Dowel (**L**) in each. Be sure to screw them in all of the way, but be careful not to over tighten them (USE A HAND HELD PHILIPS SCREWDRIVER, NOT A DRILL). REPEAT THIS STEP FOR THE REMAINING CABINET VERTICAL.

ASSEMBLING THE MURPHY BED

STEP 1: Position all of the parts approximately 24 – 36 inches from the wall where you plan to install the bed. Lay them out as shown below for ease of installation.

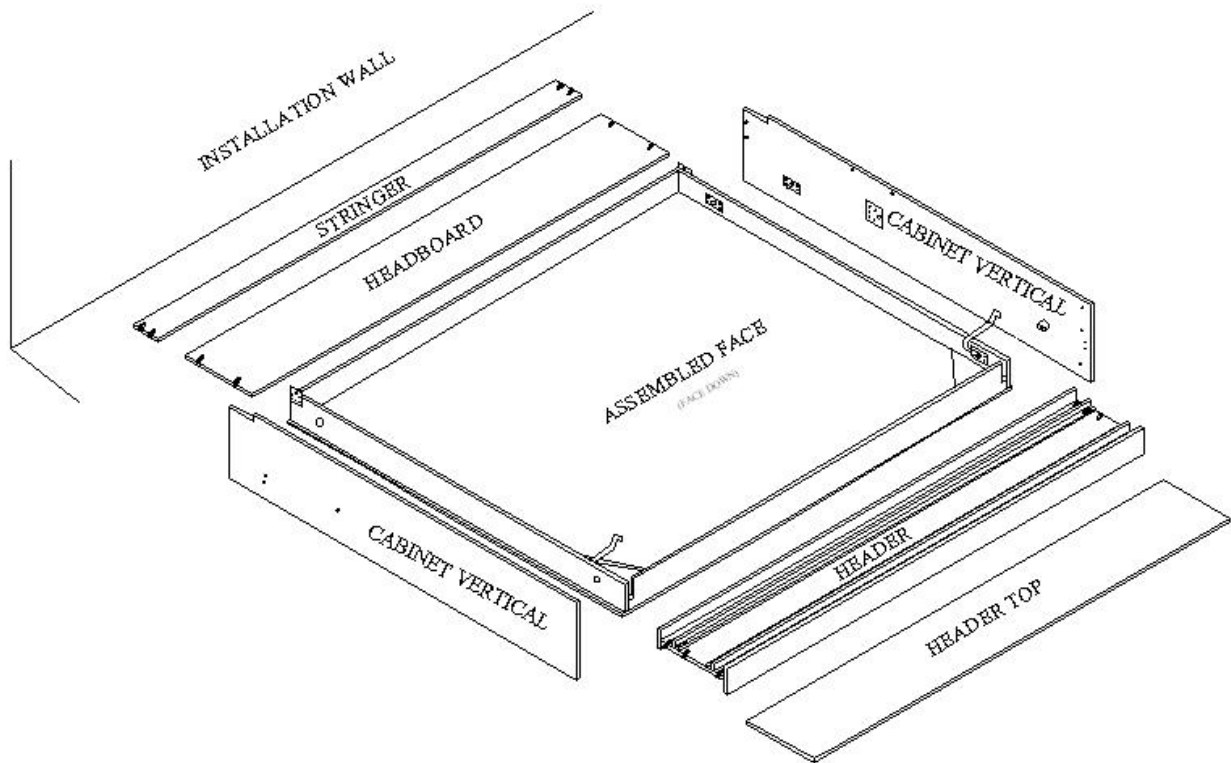

STEP 2: Place a Thick, White Nylon Washer (**K**) on the Pivot Bar on each Pivot Pin Plate (**D**) and stand the Cabinet Verticals on their finished (front) edge.

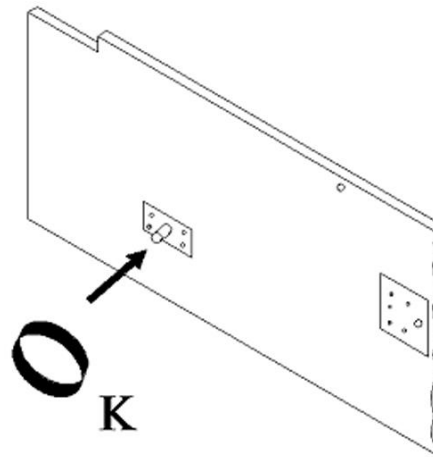
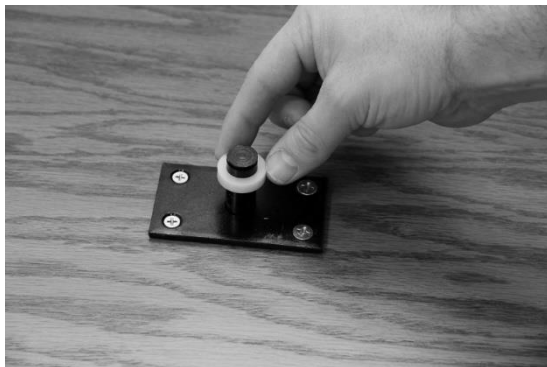

STEP 3: Slide the Pivot Pins all of the way into the Pivot Holes in the Assembled Face. The Thick, White Nylon Washer (**K**) will establish the spacing needed between these pieces.

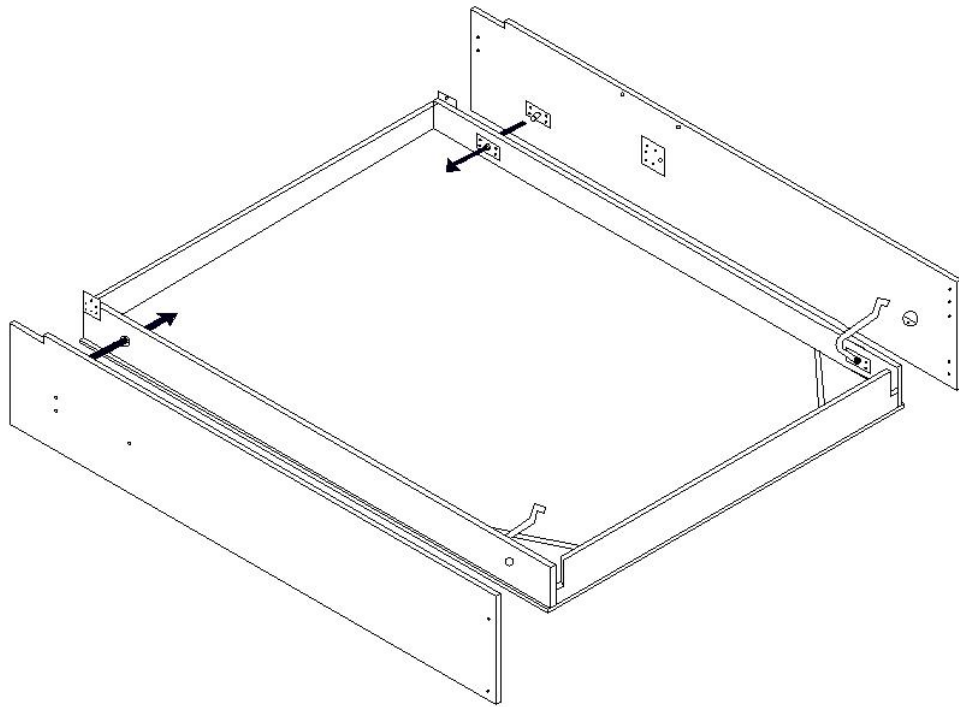

STEP 4: Snap one E-Clip (**J**) into the groove on each of the Pivot Bars locking the Cabinet Verticals to the Assembled Face.

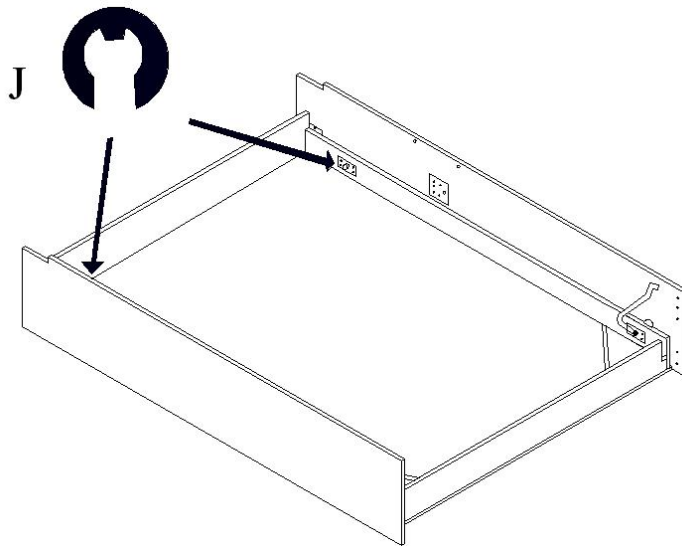

STEP 5: Next, snap the smaller end of one Piston (**A**) onto the ball receiver on the Assembled Face Plate (**C**) on the Assembled Face. The arrow should be pointing to the

top of the Murphy bed and away from the wall. REPEAT THIS STEP ON THE OTHER SIDE OF THE ASSEMBLED FACE.

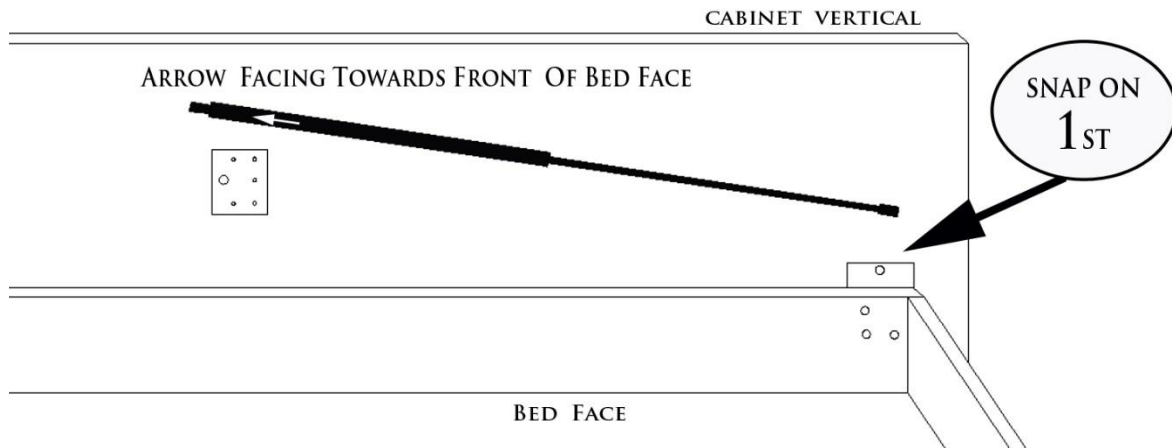

PLEASE NOTE: The Piston (A) will initially appear to be too long to snap on. This is ***NOT*** the case, as you will move the Assembled Face in the next step to align the Piston (A) with the ball receiver on the Cabinet Vertical Plate (B) on the Cabinet Vertical.

STEP 6: In order to attach the pistons to the Cabinet Verticals, you must make sure that the Bed Stopper (**I**) is not resting on the Assembled Face. If it is, simply slide it off of the Assembled Face and let the Cabinet Vertical rest on the floor. Now, having already attached both pistons to the ball receiver on the Assembled Face in **STEP 5**, have one person gently lift the Assembled Face about 6" off the ground while the second person snaps the larger end of the Piston (**A**) onto the ball receiver of the Cabinet Vertical Plate (**B**) on the Cabinet Vertical. **You may need to move the Assembled Face up and down slightly to perfectly align the ball receiver and the head of the Piston (A).** REPEAT THIS STEP ON THE OTHER SIDE OF THE ASSEMBLED FACE.

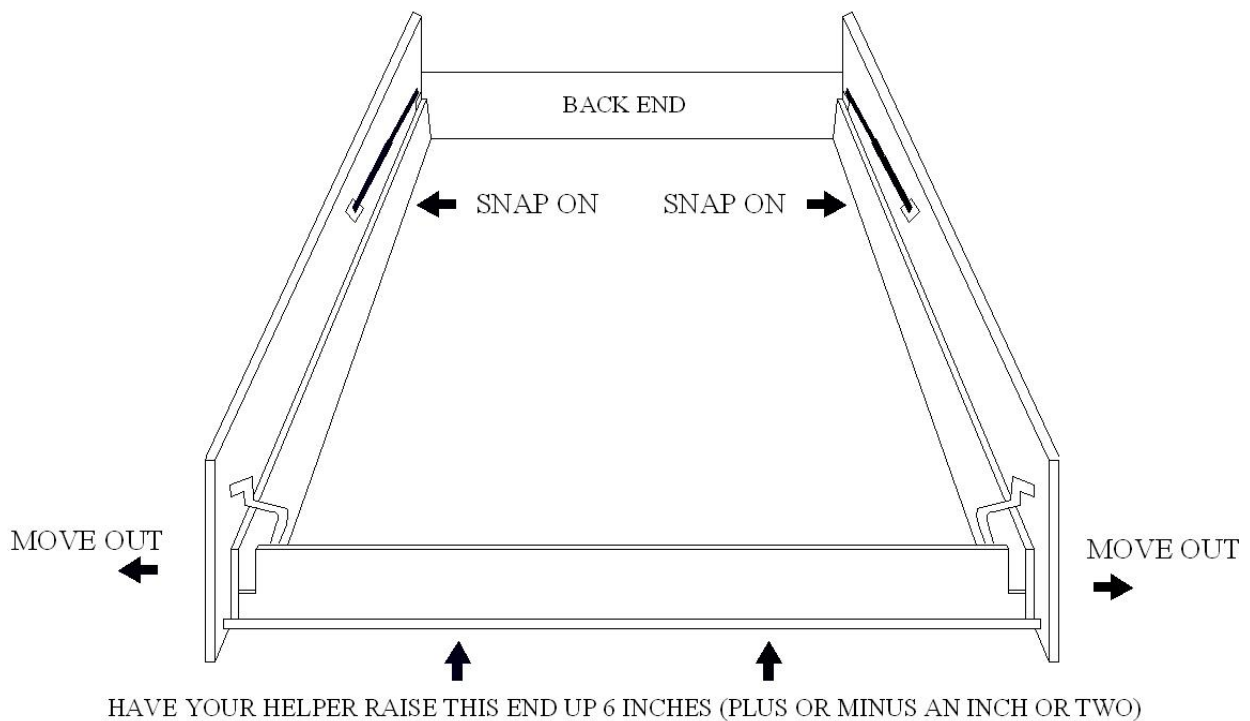

STEP 7: With the Black Cam Housing side of the Header facing into the room, attach the Header. Because of the position of the Cam Dowels, this piece can only be installed in one direction. Allow the Cam Dowels (**L**) to slip into the Cam Housings on one side. Secure this side of the Header by tightening the Phillips head within each Cam Housing using a screwdriver, not a drill. This is done by twisting the Phillips head approximately 225° until it is tight. You must finish the next step before attaching the remaining side.

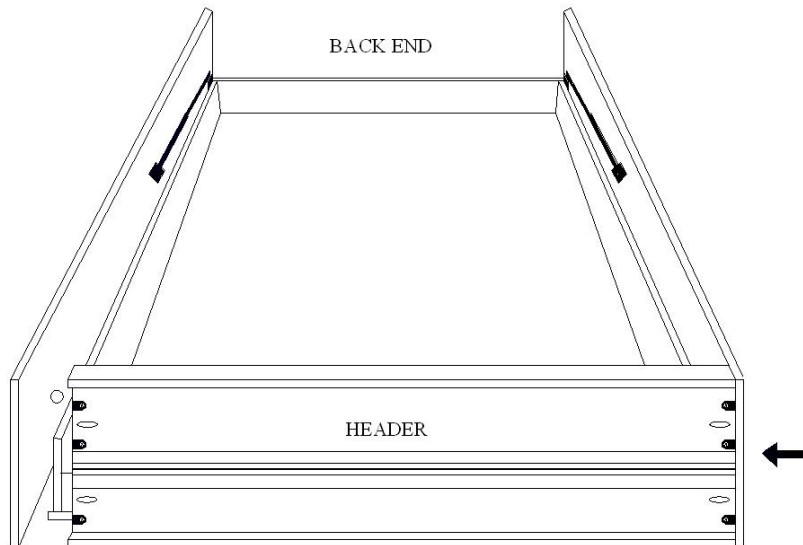

STEP 8: Place the attached side of the Cabinet Vertical on the Assembled Face using the Bed Stopper (**I**).

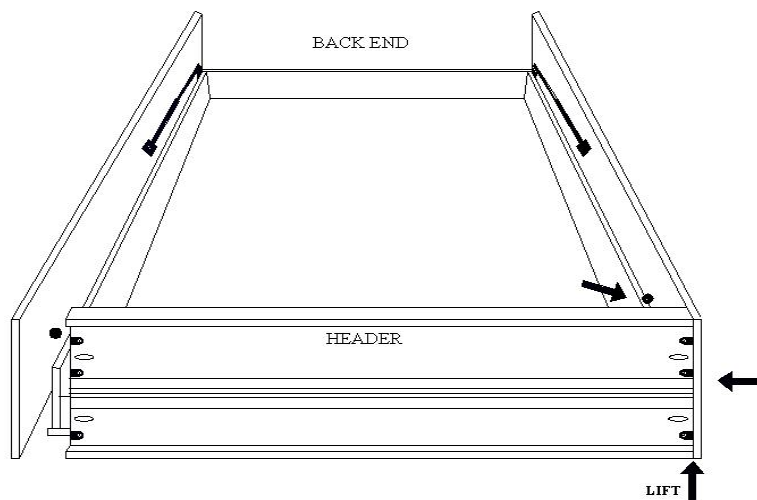

STEP 9: While lifting the unattached Cabinet Vertical and the Header slightly above the Assembled Face, allow the Cam Dowels (**L**) to slip into the Cam Housings. Secure this side of the Header by tightening the Phillips head within each Cam Housing using a screwdriver, not a drill. This is done by twisting the Phillips head approximately 225° until it is tight. Allow this Cabinet Vertical to rest on the Assembled Face using the Bed Stopper (**I**).

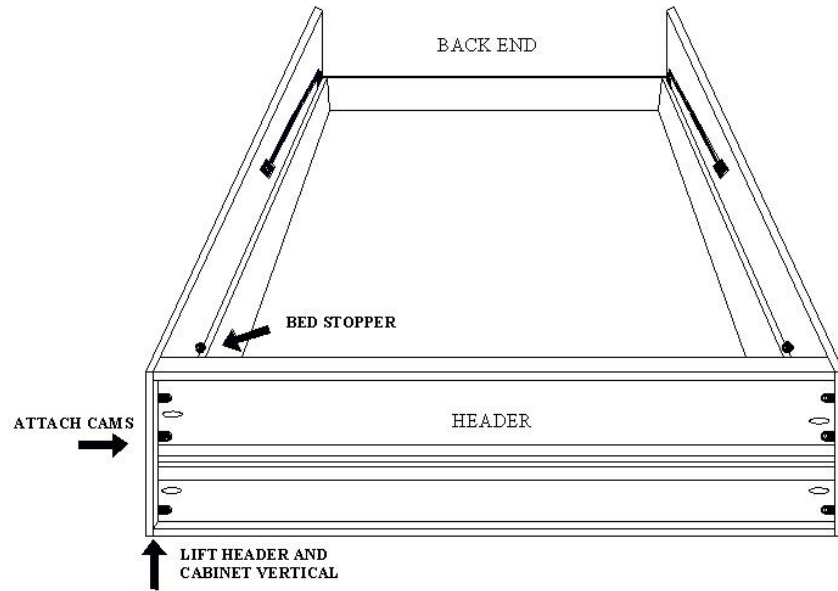

STEP 10: Drive two Silver 1½" Pocket Screws (**M**) through the pocket holes on the "L" struts on the Header into each side of the Cabinet Verticals using the slotted through holes. Make sure to do this on both sides.

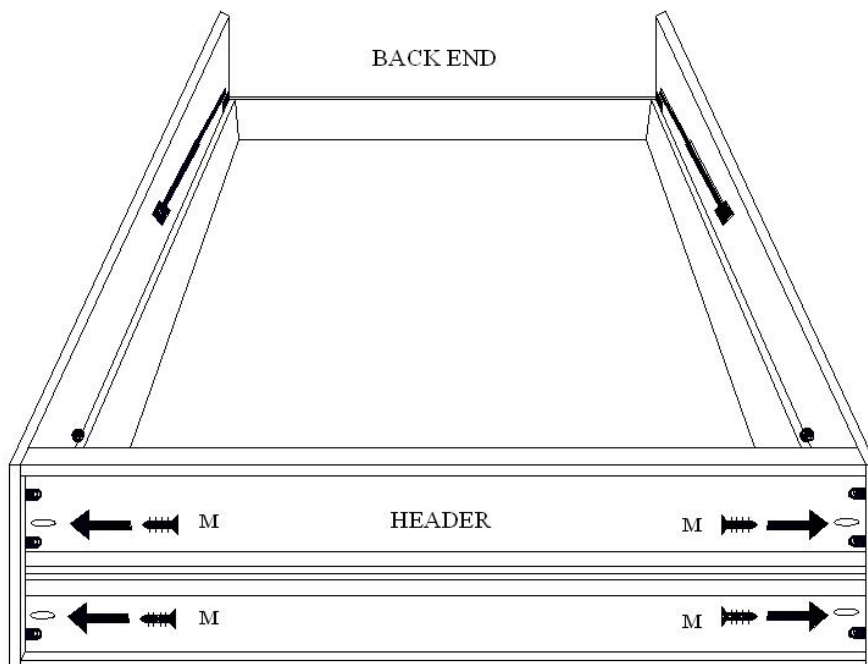

STEP 11: With the Black Cam Housing side of the Headboard facing attach the Headboard. Follow the same Cam fastening procedure as with the Header.

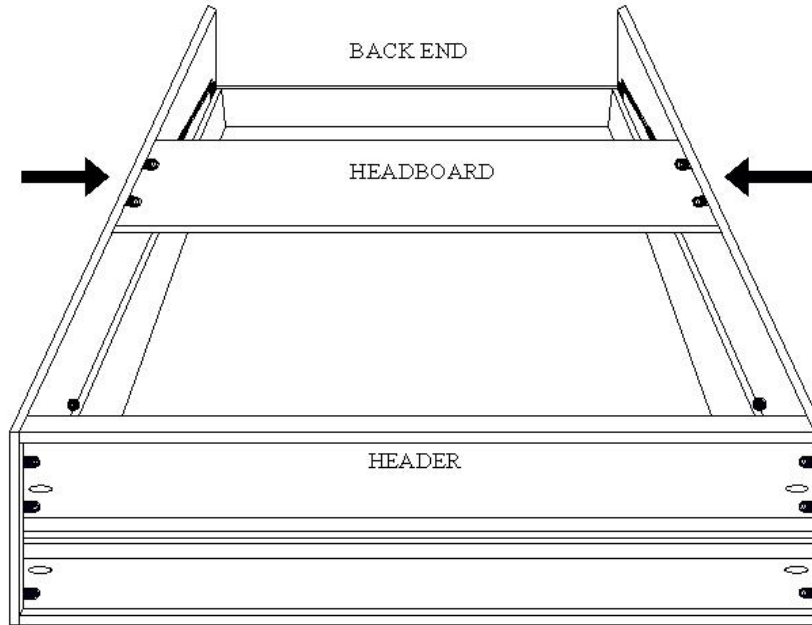

STEP 12: With the Black Cam Housing side of the Stringer facing toward the wall attach the Stringer. Follow the same Cam fastening procedure as with the Headboard and Header. (Notice this view is rotated 180° from the view above.)

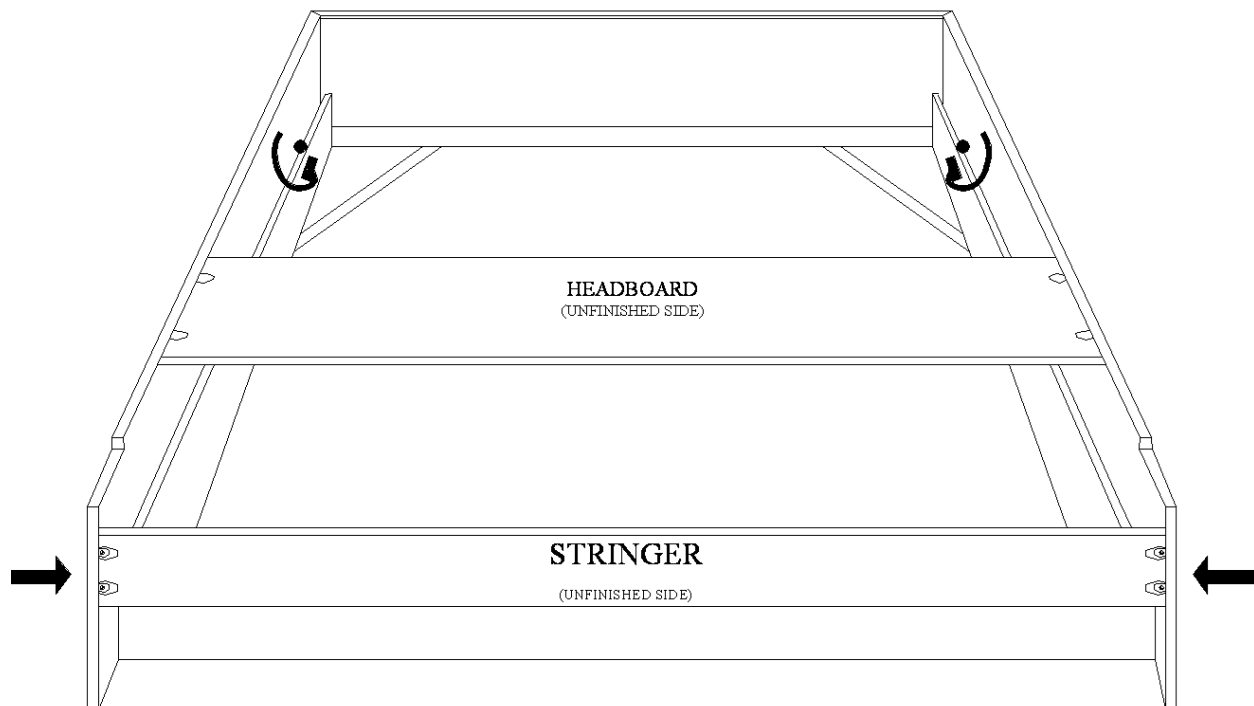

STEP 13: With the bed fully assembled and with two people, CAREFULLY lift the bed upright. If installing this in an area that has a hardwood or tile floor, be careful not to allow the bed to slide when lifting.

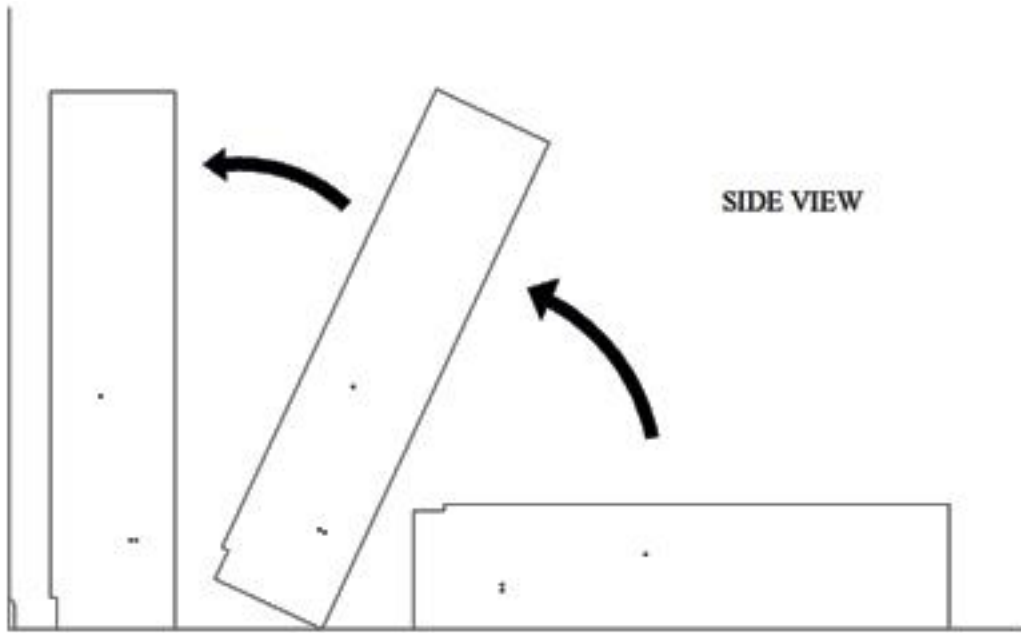

By gently tapping the Cabinet Verticals (as needed) to the right or left, adjust the bed so that the gap between the Assembled Face and the Cabinet Verticals is equal all the way around.

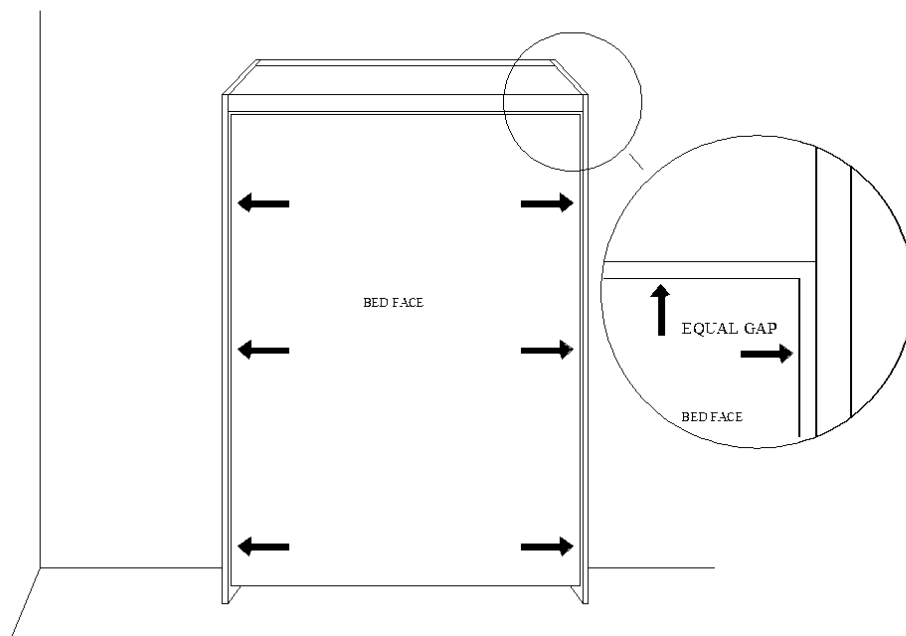

YOU ARE NOW READY TO MOUNT THE BED TO THE WALL!

STEP 14: Using an electronic stud finder and following the manufacturers instructions for use, locate the studs in the wall as shown. Mark an "X" to indicate the **CENTER** of the stud. Locate as many studs as you can within this space (minimum of 3, preferably more). This will vary for concrete, brick, or lathe and plaster walls.

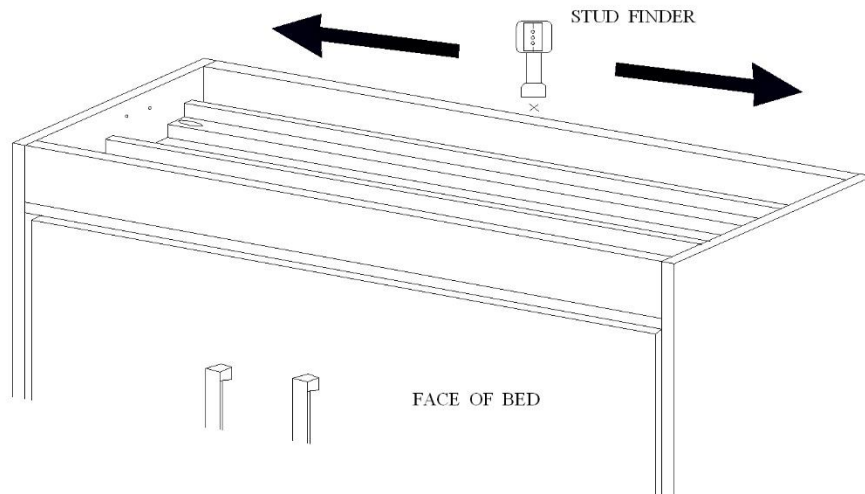

In the locations where you have located and marked the center of the studs, drill a 1/8" pilot hole through the back of the Header. Do not go all the way into the stud with this hole, just into the wood strip.

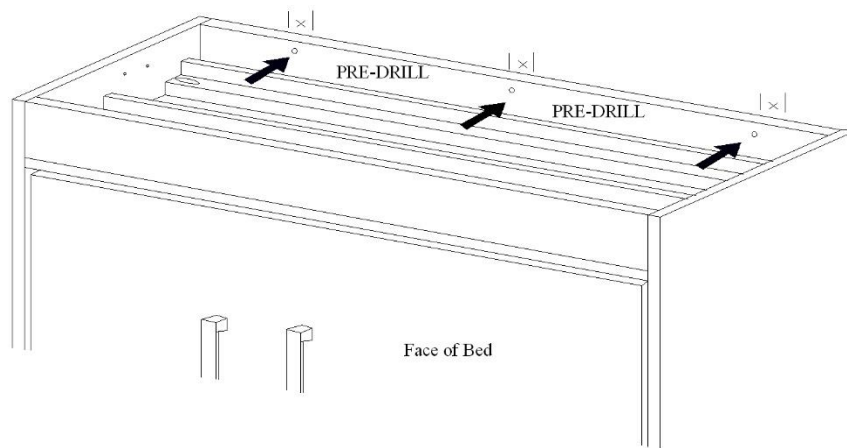

Finally, making sure that the gap around the bed is equal, drive a Black 3" Wood Screw (**N**) into each predrilled hole and into the wall studs. You may consider different fasteners for different wall types. **MAKE SURE THAT THE SCREWS ARE IN THE STUD AND THAT THE HEADER IS TIGHT TO THE WALL.** You will know you have hit the studs if it's more difficult to turn the screw. If not, you are into the drywall only. You will need to try to locate the studs again. To test this, pull on the Header a few times to make sure it does not come away from the wall.

⚠ WARNING

IT IS EXTREMELY IMPORTANT THAT THE BED BE PROPERLY AND SECURELY AFFIXED TO THE WALL. FAILURE TO DO SO CAN CAUSE SERIOUS INJURY OR DEATH!

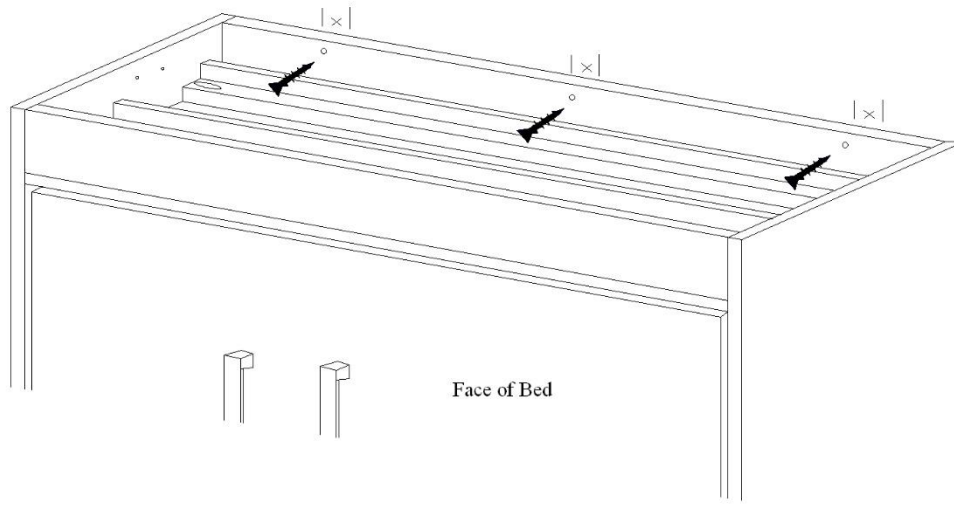

X	2	Male Keku Clip	Black	
Y	2	Female Keku Clip	Black	
Z	8	#7 x 5/8" Screw	Silver	

STEP 15: Using the #7 x 5/8" screws (**Z**), install the Male Keku Clip (**X**) on each side of the Cabinet Verticals. Pre-marked holes ease installation.

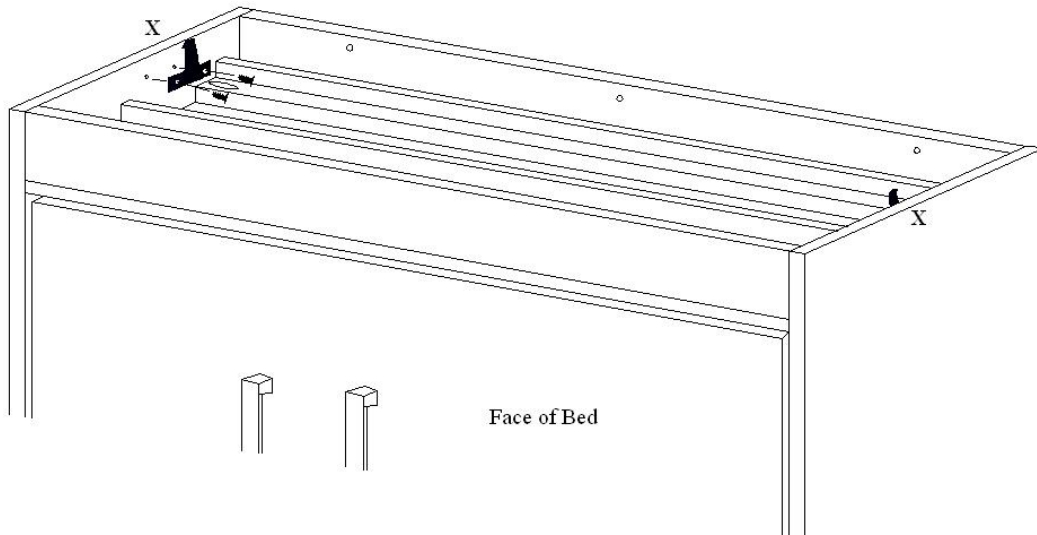

STEP 16: Using the #7 x 5/8" screws (**Z**), install the Female Keku Clips (**Y**) on each end of the Header Top. Pre-marked holes ease installation.

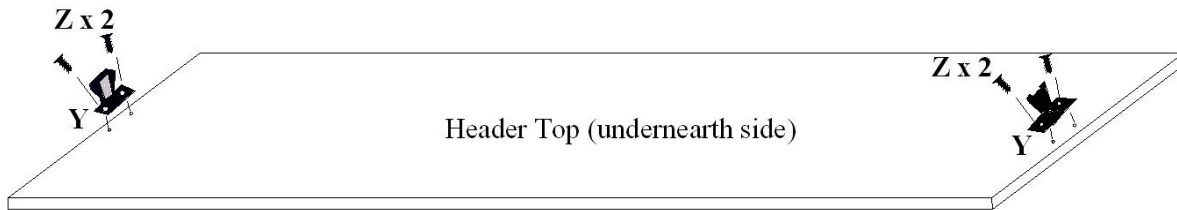

STEP 17: The Keku Clips are positioned to allow the Header Top to install only one way while remaining flush at the back of the Header. Simply push this Header Top until it snaps firmly in place.

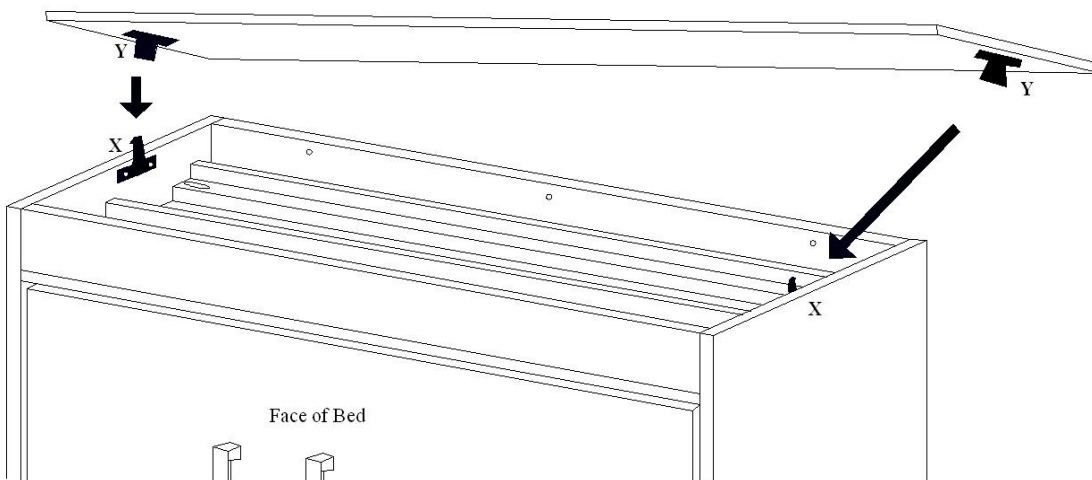

STEP 18: To install the mattress, you must first open the bed. National Casegoods Murphy beds are built to accommodate any standard innerspring mattress up to 12 inches in total thickness. Using the upper most handles (depending on style), pull the bed down into the open position. Until the mattress is installed, one person will need to hold the bed down. Without the mattress, the bed will want to return to the closed position. The weight of the mattress, once installed, will hold the bed down.

STEP 19: To keep the mattress in place when the bed is closed, simply pull the elastic straps at the bottom of the Assembled Face over the end of the mattress. These straps fit nicely **“UNDER”** the **fitted sheets** and out of plain view.

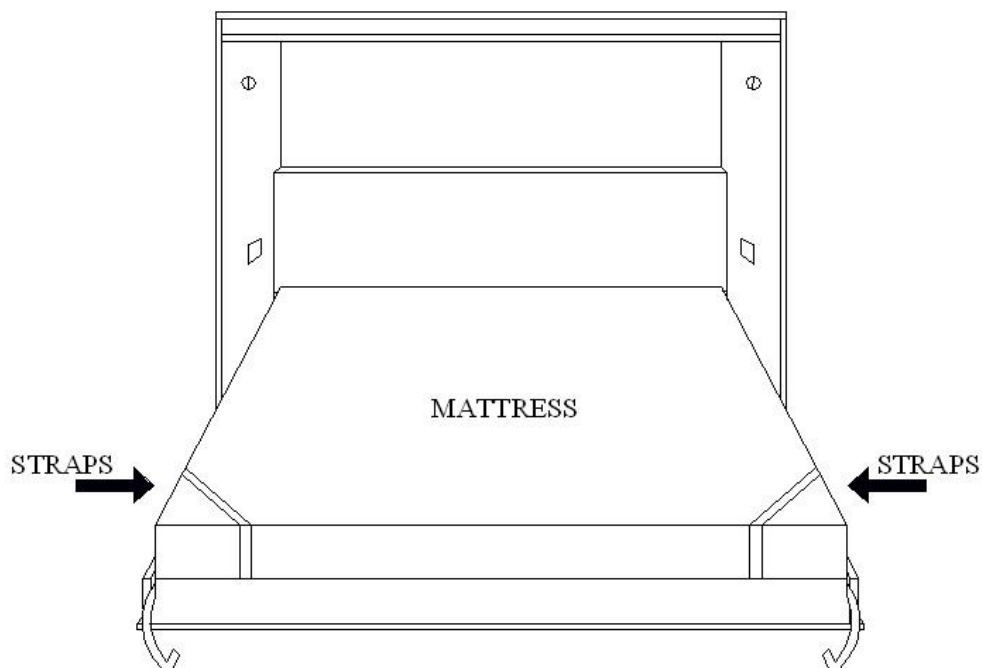

STEP 20: If you have side cabinets, these can be installed once the bed is fastened to the studs in the wall. Push the cabinet against the bed making sure that the cabinet lines up with the front edge of the bed. Once you are happy with the way the cabinet fits, drive screws from the side cabinet into the Cabinet Vertical of the bed as shown below. Be careful not to drive the screws too far and through the Cabinet Verticals!

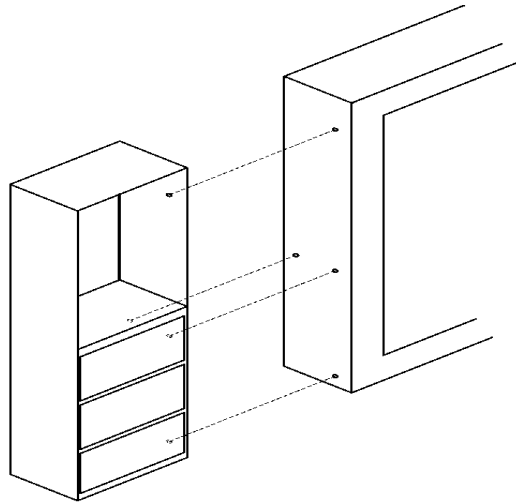

**YOU HAVE SUCCESSFULLY FINISHED THE INSTALLATION
OF YOUR NEW MURPHY BED!**

CONGRATULATIONS!



National Murphy Beds





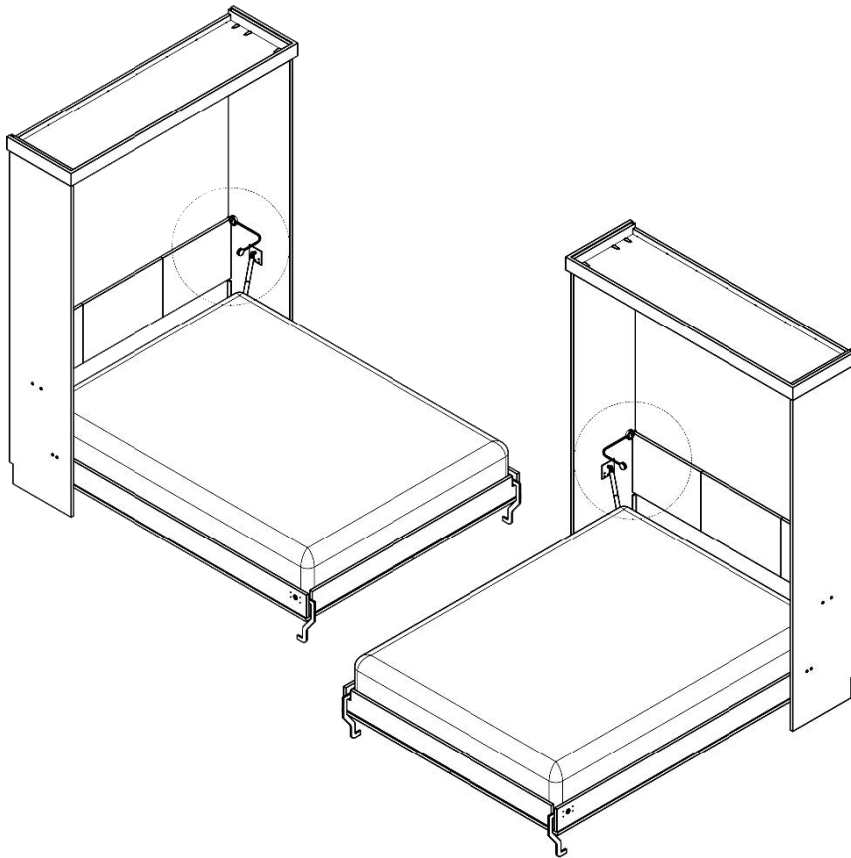

Flex Lighting Kit

Version: FLEXV1

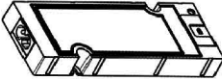

- Before you begin, confirm that all the parts and hardware is in the box. National Murphy Bed is not responsible for loss of time or hired labor due to missing parts.
- Please read the instructions thoroughly before starting this installation.
- When testing the lighting, ensure that there is power running to the outlet and if the outlet is controlled by a switch, make sure that the switch is turned on. Turn lighting off before closing bed.
- Do not install lighting without a mattress to hold the bed face down.
- If your outlet is inside of the bed, you will be able to plug in the power cord like normal. If your outlet falls outside of your bed, you will need to take the driver's side of the power cord and feed it through the base notch in the bed.

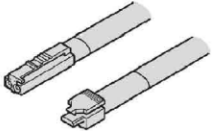
Included Parts

Part ID	Base kit qty	Total QTY with add-on kit	Name	Color	Picture
A	1	2	Flex light with magnetic ring	Black	
B	4	8	1" Screws (Phillips)	Silver	
C	1	2	Wire channel	Black	
D	1	1	Driver	Black	
E	1	1	Outlet cord	Black	
F	1	2	Flex light connector	Black wire with yellow ends	
G	0	1	Y-splitter connector	Black wire with yellow ends	

TOOLS NEEDED:



Drill



#1 Phillips Bit

1 Connect the flex light

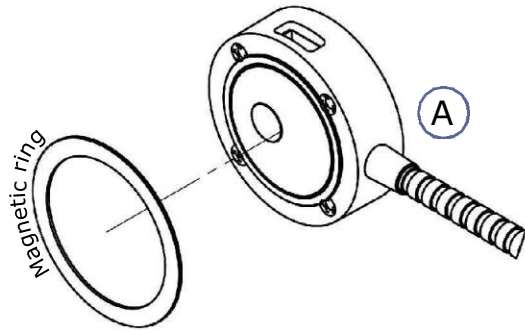

Remove the magnetic ring from the base of the flex light.

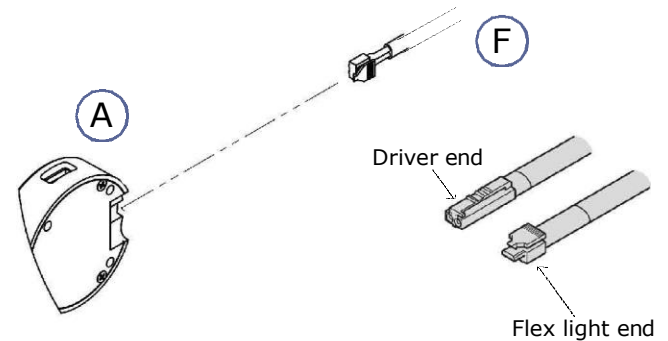

Take the flex light connecting cord and plug it into the bottom of the flex light.

2 Feed the wire behind the headboard

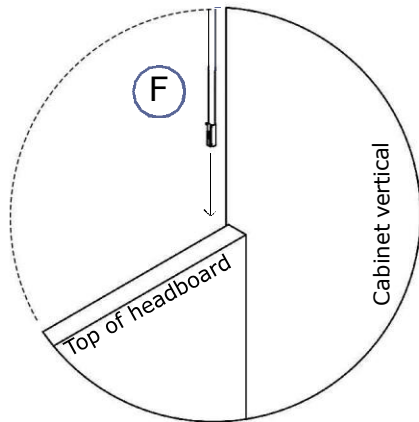

Take the driver end of the flex light connecting cord and feed it behind the headboard

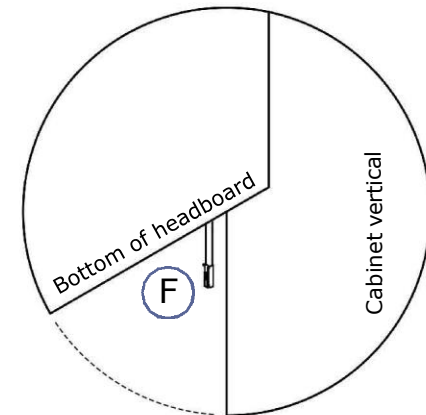

Ensure that the driver end reaches below the bottom of the headboard.

3

Attach the flex light

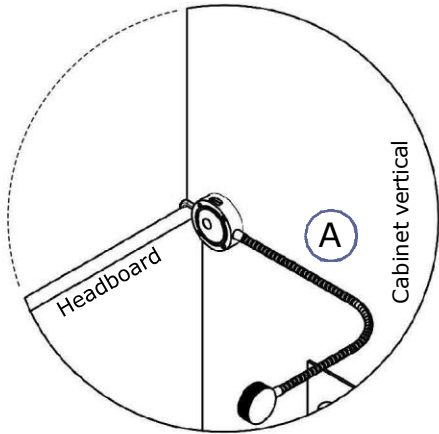

Hold the flex light against the chosen cabinet vertical so that the flex light connecting cord is resting on the top of the headboard.

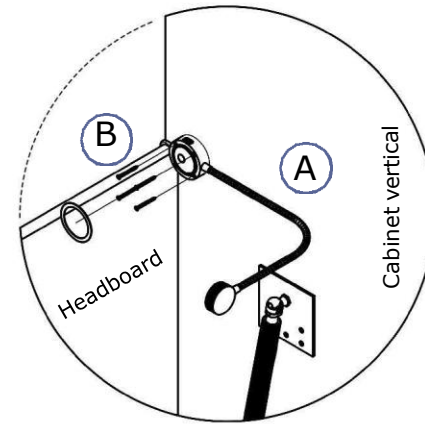

While holding the flex light, use the included four screws to secure the flex light to the cabinet vertical. Once all four screws have been attached, place the magnetic ring back onto the flex light.

4

Optional: Install the add-on flex light kit

If you have ordered the flex light add-on kit, repeat steps 1 through 3 on the opposite cabinet vertical of the bed. If you did not order this kit, continue to Step 5.



Connect the driver end of the y-splitter connector to the yellow port on the driver.

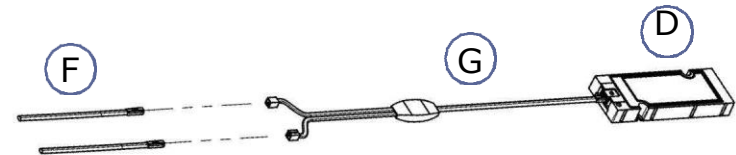

Connect both driver ends of the flex light connecting cord into the flex light ends of the y-splitter. Once this step is complete skip step 5 and continue to step 6

5 Connect the Driver

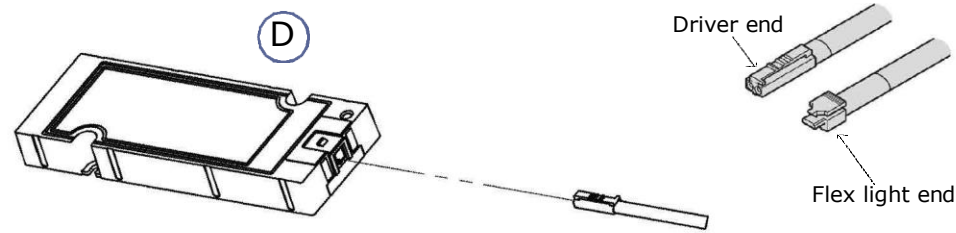

Connect the driver end of the flex light connecting cord to the yellow port on the driver.

6 Plug in the driver and cord management

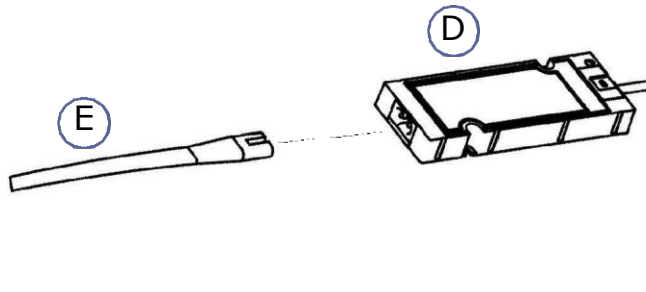

Plug the outlet cord driver end into the driver. If the outlet is outside of the bed, you will need to feed this end through the notch in the cabinet vertical.

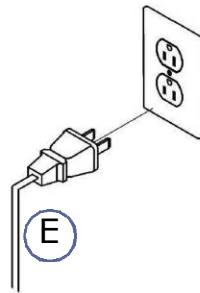

Plug the other end of the outlet cord into a standard wall outlet

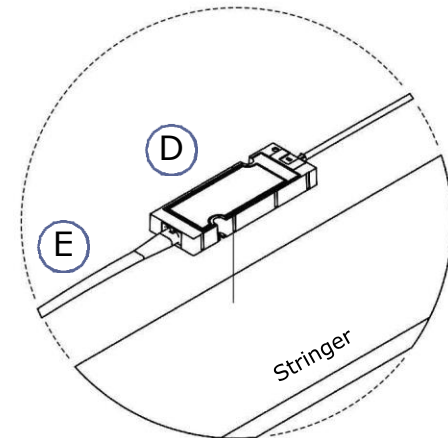

Place the driver onto the stringer on the bottom of the bed, closest to the wall. Use the included double-sided tape to make sure the driver stays on the stringer.

6 Plug in the driver and cord management (Cont.)

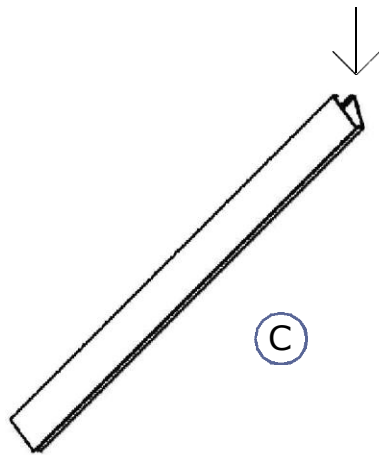

If desired, add the included wire channel to tidy up the cords below the headboard. Open the wire channel by pulling apart the end of the channel and continue down the seam.

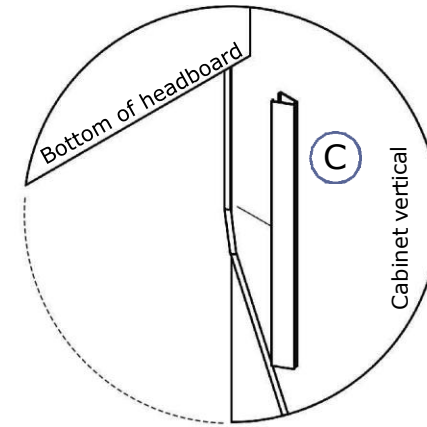

Place the cord into the wire channel and close the channel by pressing down on the front of the channel. To affix to the bed, remove the adhesive backing and apply the channel to the rear of the cabinet vertical. The included wire ties can be used to also tidy up any longer wires you may have.

Operation

- The flex light has three options: off, dim, and bright. You can cycle through these modes by pressing the button on the base of the flex light.
- Ensure that there is power to the outlet that you are using. If the wall outlet is controlled by a wall switch, then you need to turn the switch on.
- Turn the lights off before closing the murphy bed.

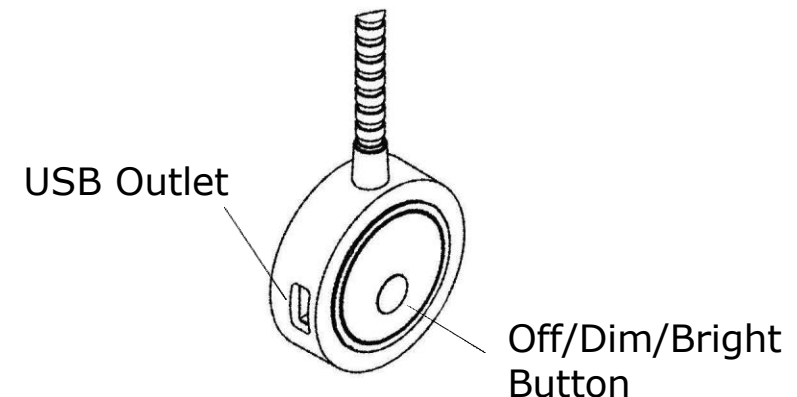

Standard Lighting Kit Diagram

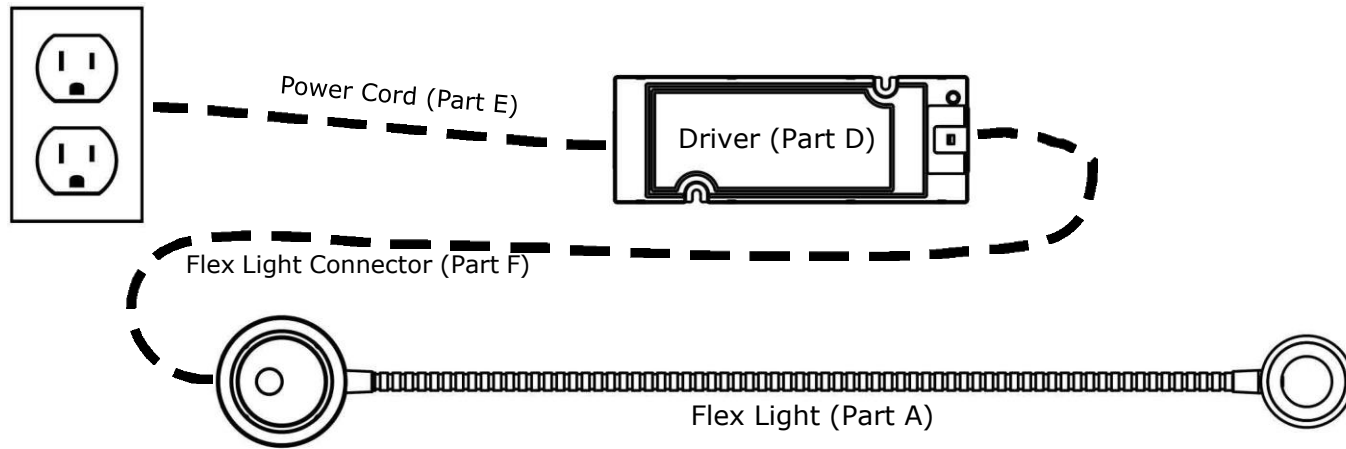

Add - On Lighting Kit Diagram

