

For more information visit <https://broncbustertx.com/>

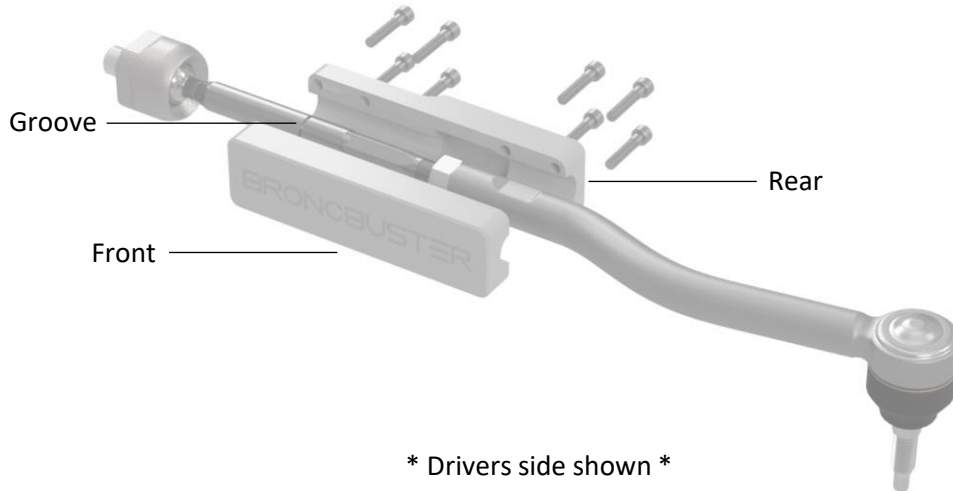

1. Locate the driver and passenger BusterBrace by making sure that BroncBuster faces forward, with the larger opening for the tie rod facing the tires.
2. Slide the rack boot towards the center of the vehicle to make room for the brace.
3. Place the brace halves over the tie rod and start the allen bolts by hand, allowing the assembly to slide and rotate.
4. Slide the assembly towards the boot to overlap the inner tie rod (groove) and rotate the brace so that the bolts face the rear.
5. Torque the 6 x 1mm grade 12.9 allen bolts to 13 ft lbs lubed / 17 ft lbs dry



For more information visit <https://broncbustertx.com/>



1. Locate the driver and passenger BusterBrace by making sure that BroncBuster faces forward, with the larger opening for the tie rod facing the tires.
2. Slide the rack boot towards the center of the vehicle to make room for the brace.
3. Place the brace halves over the tie rod and start the allen bolts by hand, allowing the assembly to slide and rotate.
4. Slide the assembly towards the boot to overlap the inner tie rod (groove) and rotate the brace so that the bolts face the rear.
5. Torque the 6 x 1mm grade 12.9 allen bolts to 13 ft lbs lubed / 17 ft lbs dry

