

TROUBLESHOOTING

PROBLEM	POSSIBLE CAUSE	SOLUTION
Pump stops running OR Severe decrease in flow rate occurs.	Faulty Power Source	Check all power sources and connections, GFCI and Circuit Breakers. Test pump in a second outlet or power source.
	Internal Thermal Protection Device has Tripped	Unplug and allow the pump to cool down. Check inlet for debris and remove before re-starting.
	Slotted Base or Intake is clogged with debris	Disconnect power and clean out debris from around Base or Impeller Intake Inlet.
Motor runs but does not pump any water.	Pump Intake is above water level	Shut off Pump so as not to overheat and discontinue use until water level has risen OR relocate pump to deeper water.
	Pump is cavitating due to water level getting too low	
	Air Lock is occurring inside pump chamber	Disconnect power from the pump. Turn pump upside down in the water to release any trapped air pockets within the chamber and then return pump to upright position. Reconnect power and test.
Pump makes "squealing" sound when plugged in	Ceramic bearings are running dry	REMOVE POWER IMMEDIATELY Verify Slotted Base is submerged
Pump does not start after replacing the Rotor / Impeller Ass'y	The 6mm Screws (<i>item 7</i>) which fasten the volute to the housing have been overtightened.	Remove base, loosen flange nuts, back off screws 1/4 turn. Re-tighten flange nuts and re-attach base. Note: A threadlocker should be applied to all machine screws.

LIMITED WARRANTY

EG.Danner Mfg.,Inc. will repair or replace any unit found to be defective within one year of original purchase. Cutting or altering cord, removing or defacing product labels, running pump dry or without the use of an automatic float switch voids any warranty consideration. For warranty repair, return only the part that is defective to our factory. Please include a dated proof of purchase and \$20.00 for postage and handling. Damages or injuries resulting from negligence, shipping, handling, improper installation, maintenance or misuse of the product are not covered by the warranty. This warranty gives you specific legal rights. You may have other rights which vary from state to state. To validate this warranty keep your proof of purchase. (Copy of your sales receipt.).

1 year limited warranty does not cover externally attached components. (i.e., slotted base, mounting plate, elbow, fitting, automatic float switch)



SAVE THESE INSTRUCTIONS

Model # 20370 Utility Pump

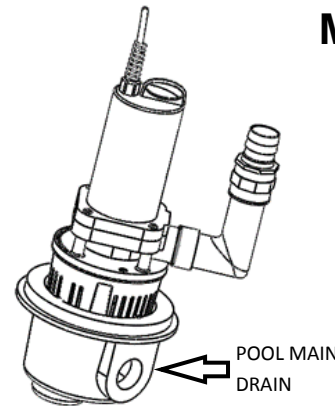

PUMP SHOWN SEATED INSIDE POOL MAIN DRAIN

Specifications:

MAX FLOW RATE	5373 GPH - SEE TABLES 1 & 2
MAX HD HT	32 FEET - SEE TABLES 1 & 2
MIN WATER DRAW	2 INCHES DEEP
VOLT/FREQ.	120 VOLT / 60Hz
WATTS	593
AMPS	4.9
FITTINGS INCLUDED	ELBOW, COUPLING and 1 1/2" BARBED

This versatile pump is designed primarily for use in draining in-ground pools for the purposes of maintenance and liner re-placements. The slotted "basket-type" base measures less than 5 1/2" in diameter. This dimension in conjunction with the (4) cored reliefs @ 90 degrees apart, allows it to fit inside the drain and seat itself several inches below the top surface of the main drain flange, thereby draining ALL the water in the pool. It can also be used in Irrigation, Pond and any other general watering or de-watering application.

WARNING : POOLS ARE DANGEROUS TO SMALL CHILDREN. NEVER LEAVE CHILDREN UNSUPERVISED NEAR A POOL.

Operating Precautions:

- DO NOT RUN PUMP DRY.**
- DO NOT OPERATE PUMP WITHOUT AN AUTOMATIC FLOAT SWITCH.**

- DO NOT USE IN HIGHLY ABRASIVE ENVIRONMENTS OR IN WATER WITH LARGE, UNDISSOLVED SOLIDS.

- NEVER USE PUMP IN ANY LIQUID OTHER THAN WATER.

General Maintenance:

- ALWAYS RINSE AND FLUSH PUMP THOROUGHLY AFTER USE IN SALT WATER AND ANY TYPE OF ACID WASH PROCEDURES.

FEATURES:

Construction – Durable, High Strength ABS Resin.

Slotted base – Prevents debris from entering the pump while providing flow rates up to 5400 gph. (measured at zero head height)

Performance – Pumps up to 4400 gallons per hour at 10 feet of lift.

Bearings – Heavy Walled Ceramic

Shaft – ½ inch Diameter Ceramic

Impeller- High Flow Rate Vortex type for Silent Operation and High Efficiency.

Active Cooling – Water being pumped cools the motor during discharge.

Serviceability – Pump Intake, Impeller/Rotor Ass’y and Base can easily be removed for service or replacement.

Warranty - One Year Limited.

SPECIFICATIONS:

Motor – *Continuous Duty.

*Powerful & Energy efficient 120V/60Hz. Draws only 593 Watts Max.

*Thermally Protected to prevent overheating.

Power Cord – 25 ft. long, Type SJTW (UL) / C(UL) with 3-Pronged grounded type plug.

Minimum Water Depth – 2 inches



ELECTRICAL PRECAUTIONS

Always use a properly grounded outlet. Do not immerse the plug in water. DO NOT REACH INTO THE WATER TO REMOVE THE PLUG. TURN OFF CIRCUIT FIRST. A “Drip Loop” in the cord should be used. A “Drip Loop” is a loop in the cord below the level of the receptacle or plug that prevents any water from travelling along the cord and getting into the outlet. The National Electrical Code requires that a Ground Fault Circuit Interrupter (GFCI) be installed in every branch supplying the equipment. Your dealer can provide GFCI units. NEVER REMOVE THE GROUND PIN FROM THE PLUG.

WARNING—Risk of electric shock. This pump is supplied with a grounding conductor and grounding–type attachment plug. To reduce the risk of electric shock, be certain that it is connected only to a properly grounded, grounding-type receptacle.

WARNING: FOR YOUR PROTECTION, ALWAYS UNPLUG THE UNIT FROM ITS POWER SOURCE BEFORE INSTALLING OR SERVICING. DO NOT REACH FOR, REMOVE OR DISASSEMBLE UNIT BEFORE DISCONNECTING POWER TO IT.

Service and Maintenance

In the event your pump requires disassembly due to a clogged intake, a jammed Impeller or if a Rotor/Impeller replacement service is required, see the following steps below.

REMEMBER: ALWAYS DISCONNECT PUMP FROM POWER SOURCE BEFORE SERVICING !

1. Remove the four self tapping screws (*item 1*) which hold the slotted base (*item 2*) onto the Interface Plate (*item 4*).
2. Remove the four flange nuts (*item 3*) using a 10mm socket, box or open end wrench.
3. Remove the Interface Plate (*item 4*) from the Pump.
4. Remove the four 6mm threaded screws (*item 7*) from the pump head.
5. Remove the volute (*item 6*).
6. Remove the Impeller / Rotor assembly and gasket (*item 12*)
7. Replace parts back in reverse order. Be sure to apply a removable threadlocker to retain item 3 nuts to item 7 screws.

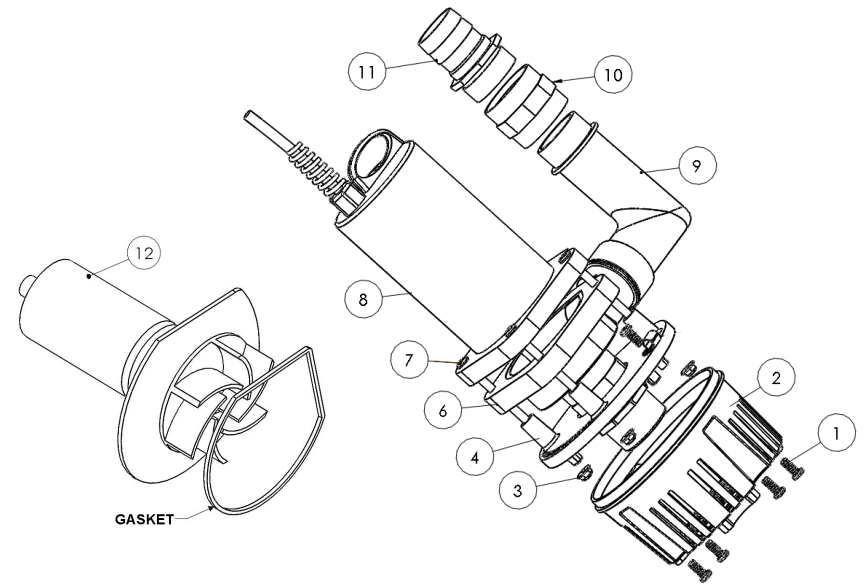

Replacement parts

No.	Description	Part No.
12	ROTOR w/ GASKET	21100
11	BARB FITTING	ZL340
10	COUPLING	ZL341
9	ELBOW	ELBOW
2,4	SLOTTED BASE & PLATE ASS'Y	20370BASE

FLOW RATE TABLES

FLOW RATE (GPH)	HEAD HEIGHT (FEET)
5142	0
4615	5
4000	10
3050	15
2571	20
2000	25
0	32

Table 1
Vertical Flow
(90 deg. Elbow attached)

FLOW RATE (GPH)	HEAD HEIGHT (FEET)
5373	0
5142	5
4390	10
3790	15
3000	20
2250	25
0	32

Table 2
Horizontal Flow
(No Elbow attached)