

# PONDMASTER®

## LOW PRESSURE FILTER SYSTEM

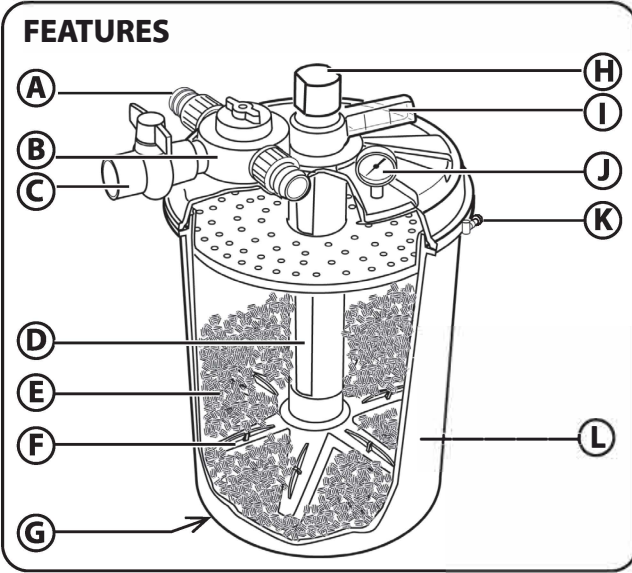

- A - Quick Connect Hose Fitting** - For easy tool-free hose removal and reassembly.
- B - Clear Multiport Valve** - Control and visually monitor water clarity during backwash/rinse operation.
- C - Waste Port Valve** - Convenient ball valve directs waste water.
- D - UV Lamp (PUV Models only)** - Internal long thin bulb assembly forces water close to bulb for longer contact time with rays. Can be added to all models.
- E - Bio-Matrix Media** - Reusable media affords maximum surface area for beneficial bacterial growth.
- F - Agitator** - Efficiently unlocks waste from media with minimum water loss during backwash/rinse.
- G - Optional Bottom Valve (Not Shown)** - Available and recommended to facilitate seasonal draining.
- H - UV Lamp Ballast (PUV Models only)** - Top mount for convenient access. Can be added to all models.
- I - Agitator Handle** - Dual purpose - Manually turns internal agitator; also allows safe monitoring of UV Lamp status.
- J - Pressure Gauge** - Displays internal pressure to indicate when routine backwash is necessary.
- K - Stainless Steel Clamp** - Stainless steel security with Hex Locknut.
- L - Heavy Duty Poly Canister** - Weather proof -- designed for burial near pond.



**For Your Information:**  
Each piece of Bio-Matrix Media has 2.25 square inches of surface area available for beneficial bacterial colonization.

## Basic Setup Guide See Additional instructions for important details

PUV-4000, PUV-2000, PUV-1000 - Biological, Mechanical and Ultraviolet Filtration  
P - 4000, P - 2000, P - 1000 - Biological and Mechanical Filtration (UV Clarifier not included)

**DO NOT OPEN FILTER!**  
It is completely assembled and pressure tested at the factory  
See Section 9 of main instructions

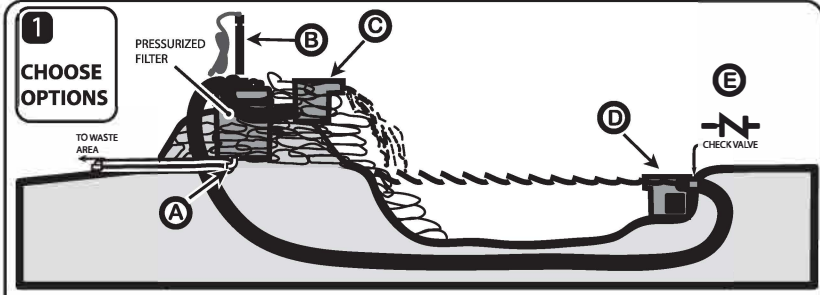

- 1 CHOOSE OPTIONS**
- A BOTTOM DRAIN** • Simplifies winter Maintenance; drains water from the bottom.
  - B ULTRAVIOLET CLARIFIER** • Uses ultraviolet light to inhibit algae from reproducing.
  - C PRO BIOLOGICAL FILTER AND FALLS** • Produces a dramatic waterfall effect.
  - D PRO SKIMMER** • Keeps debris away from intake. Skims, protects pump.
  - E CHECK VALVE** • Best installed between pump and filter.
  - F VALVED BYPASS (Not Shown)** • Split water flow between filter and a waterfall.

- 2 GATHER MATERIALS**
- To set up the filter you will need to supply the following items.
- Hoses -- 1 1/2" Flexible hose (recommended)
  - Stainless Steel Hose Clamps -- for connections to pump and filter drain
  - Plumber's Teflon tape
  - In-Line Check Valve
  - 1 1/2" insert MPT by BARB adapter for waste valve
- OTHER SUPPLIES MAY BE NECESSARY FOR OPTIONS AND ACCESSORIES CHOSEN.

- 3 CHOOSE LOCATION and DETAILS**
- This filter must be connected to an external water pump. The water pump can be submersible or above ground depending on your preference. Pondmaster makes several perfectly matched pumps and accessories to complete your filter system. Please note the following:
- The intake for the water pump should be positioned at the opposite end of the pond from the water return.
  - The filter drum must be buried up to an inch below the pressure clamp. If positioned above ground use the backfill from digging the pond.

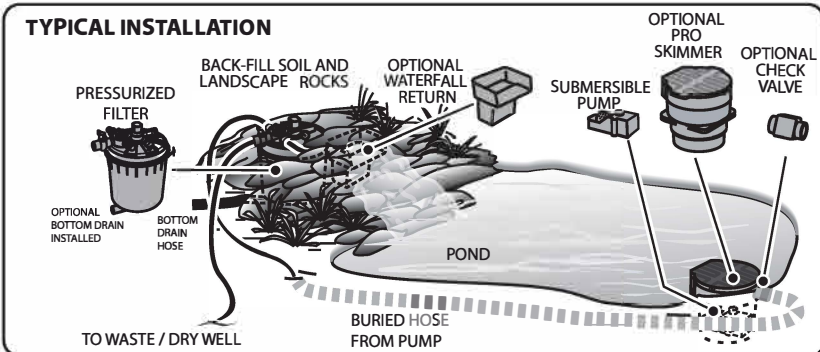

DANNER MFG. INC. • Islandia, New York 11749  
Visit our web site at [www.Dannermfg.com](http://www.Dannermfg.com)

**4 CHOOSE PUMP** **IMPORTANT INFORMATION!** Your Pressurized Filter System works best within a certain range of flow and pressure. Exceeding these values will cause leakage or breakage of filter or its components.

PRESSURIZED FILTER	MAXIMUM PUMP CAPACITY (GAL/HR)	MAXIMUM BASELINE PRESSURE (P.S.I.)	FOR POND SIZED (GALLONS)
P1000 or PUV1000	2000	5	UP to 1000
P2000 or PUV2000	2000	5	UP to 2000
P4000 or PUV4000	4000	5	Above 2000

NOTE: If the pump you would like to use exceeds these values, use a Valved Bypass.

**5 SET UP HOSES** Unpack the Main filter unit. It is completely factory assembled and pressure tested. Do not open the cover. If your filter includes the UV Clarifier, place it aside until after the filter is in its final mounted position. Installation details of the UV Clarifier are included.

**ATTACH QUICK CONNECTS AND WASTE VALVE**

**ATTACH HOSES**

**6 TEST SETUP** Before turning on pump, set valves as shown in the FILTER SETTINGS illustration. Other settings will be used for maintenance.

**FILTER SETTINGS**

**BACKWASH SETTINGS**

**RINSE SETTINGS**

- 1) The **Waste Port Valve** should be in the **CLOSED** position.
  - 2) Turn the **Multiport Valve** to the **FILTER** position.
  - 3) Turn on the pump and check the hoses and clamps.
- 1) The **Waste Port Valve** should be in the **OPEN** position.
  - 2) Turn the **Multiport Valve** to the **BACKWASH** position.
  - 3) Agitate the filter media by moving the agitator handle back and forth.
- 1) With **Waste Port Valve** open turn main valve to **RINSE** position.
  - 2) Turn the agitator handle left to right until water clears up.
  - 3) Turn the **Multiport knob** back to the **FILTER** position and close the **Waste Port Valve** to resume filtering. Check Gauge weekly.

**7 GAUGE** The Pressure Gauge provides a reading immediately once filter is set up and running.

The Baseline number will vary based on your particular setup; it should not exceed 5 PSI. The PSI should continue to read close to the Baseline until debris starts to accumulate in the filter. Do not backwash until pressure rises 2 - 3 PSI over original baseline.

**NOTE: PRESSURE SHOULD NOT BUILD BEYOND 8 PSI. IF IT DOES, BACKWASH IMMEDIATELY TO PREVENT DAMAGE TO THE FILTER.**

**NOTE: This page is for quick overview. Please refer to enclosed instruction sheet to properly set up and use this filter!**

**SAVE THESE  
INSTRUCTIONS**

# **ProLine™**

**By PONDMASTER®**

## **LOW PRESSURE FILTER SYSTEM**

---

### **CARE AND OPERATING INSTRUCTIONS**

<b>MODELS</b>	<b>UPC#</b>
PUV-4000	05045
PUV-2000	05025
PUV-1000	05015
P - 4000	05040
P - 2000	05020
P - 1000	05010



# PONDMASTER®

## LOW PRESSURE FILTER SYSTEM

### INSTALLATION AND OPERATING INSTRUCTIONS

**SAVE THESE INSTRUCTIONS**

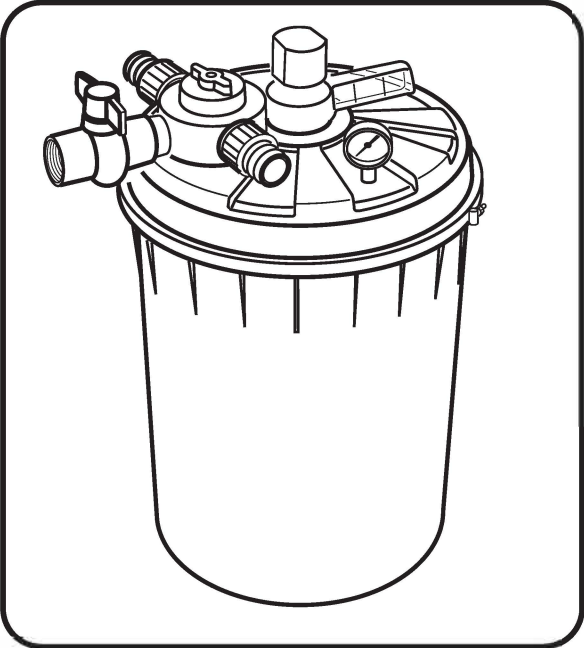

MODELS	UPC#	FILTRATION
PUV-4000	05045	Biological, Mechanical and Ultraviolet (UV Clarifier included)
PUV-2000	05025	
PUV-1000	05015	
P - 4000	05040	Biological and Mechanical
P - 2000	05020	
P - 1000	05010	

**All Kits include:** Filter Drum, Cover, Clear Multiport Valve, Waste Port Valve, Quick Connect Hose fittings, Bio-Matrix Media, Agitator, Pressure Gauge and Stainless Steel Clamp.

**NOTE:** This filter is intended to pull suspended solids out of the water column. It is NOT designed to remove leaves and large solids from the pond. It should not be used as a pond vacuum. All pumps used with this filter must be used inside a Pump Bag or with a Skimmer or prefilter to prevent large debris from entering the filter chamber and blocking the biological filtration.

### HOW FILTRATION WORKS:

Both biological and mechanical filtration are essential for every pond; without them, your fish would be harmed by ammonia generated by the accumulated fish waste. The beneficial bacteria bed that builds on the filter media nitrifies any ammonia in the pond making it a healthier environment for aquatic life. Mechanical filtration removes debris in suspension in pond water keeping it cleaner and clearer.

Biomechanical filtration depends on the establishment of a colony of bacteria on the surface of the media that converts dissolved toxic nitrogenous waste to harmless compounds. When the bacteria are given the proper environment, they grow in a thin biofilm on the surface of each piece of media. The larger the surface area of the media, the larger the bacterial colony.

The media must first establish itself to handle the load of dissolved ammonia. Depending on the water temperature, it can take 2 - 4 weeks for the filter to establish itself in the pond environment. The ultraviolet filtration should be left off during initial seeding to allow the bacteria colonies to grow. The time required varies depending on climate, weather conditions, fish load and feed rates. Until the colonies grow large enough, the pond owner must take care to monitor levels of ammonia and nitrates in the water and take appropriate measures to correct any dangerously high levels.

The ultraviolet clarifier/sterilizer (UV) produces a wavelength of light that inhibits algae from reproducing by damaging its DNA. Please note that UV light does not kill algae that cling to the sides of ponds. If your pond has string algae you can add Pondmaster Pond Fix with activated barley to inhibit growth of floating Algae and Pondmaster Oxy Scrub to remove algae from rock surfaces.

### BEFORE YOU BEGIN:

- **READ ALL CAUTIONS** -- Ponds, outdoor electricity and UV lamps can be extremely hazardous if misused.
- **CHOOSE LOCATION** for your POND FILTER ARRANGEMENT -- There are several options setting up a pond filter.
- **SELECT THE PROPER SIZE PUMP** -- The right pump will ensure safe, quality filtration. The wrong pump will lead to inferior filtration and possibly damage the filter.
- **DECIDE ON OPTIONAL ACCESSORIES** -- It is easier to install accessories BEFORE installing the filter system.
- **COLLECT ALL THE ITEMS NEEDED TO COMPLETE THE PROJECT** -- Avoid 20 trips to the hardware store!
- **READ and KEEP ALL INSTRUCTIONS** -- Know how to use and maintain your filter.

## FEATURES

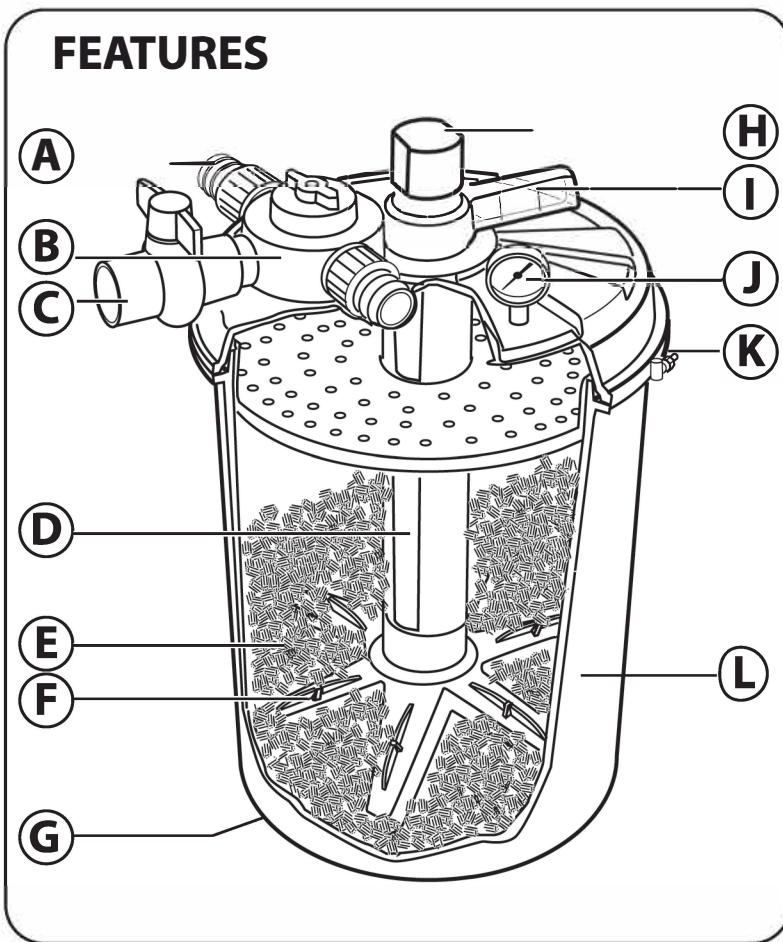

- A - Quick Connect Valve Fitting** - For easy tool-free hose removal and reassembly.
- B - Clear Multiport Valve** - Control and visually monitor water clarity during backwash/rinse operation.
- C - Waste Port Valve** - Convenient ball valve directs waste water away from pond during rinse or backwash.
- D - UV Lamp** (PUV Models only) - Internal long thin bulb assembly forces water close to bulb for longer contact time with rays. Can be added to all models.
- E - Bio-Matrix Media** - Reusable media affords maximum surface area for beneficial bacterial growth.
- F - Agitator** - Efficiently unlocks waste from media with minimum water loss during backwash/rinse.
- G - Optional Bottom Valve** (Not Shown) - Available and recommended to facilitate seasonal draining.
- H - UV LAMP Ballast** (PUV Models only) - Top mount for convenient access. Can be added to all models.
- I - Agitator Handle** - Dual purpose - Manually turns internal agitator; also allows safe viewing and confirmation of UV Lamp status.
- J - Pressure Gauge** - Displays internal pressure to indicate when routine backwash is necessary.
- K - Stainless Steel Clamp** - Stainless steel security.
- L - Heavy Duty Poly Canister** - Weather proof -- designed for burial near pond.

**WARNING!** PONDS ARE DANGEROUS TO SMALL CHILDREN!  
NEVER LEAVE CHILDREN UNSUPERVISED NEAR A POND.

### WARNING

**If your filter includes a UV Clarifier please read the following:**

Do not attempt to look directly at bulb when lit; the ultraviolet light produced will harm your eyes.

Do not allow exposure to your skin by the ultraviolet light as prolonged exposure it will cause burns.

The units are provided with a safety switch that disables power to the bulb when the light unit is not assembled. Do not attempt to override this switch.

### WARNING

This unit is for seasonal use only. It should not be used in freezing conditions because the quartz tube included with UV Clarifiers will crack, permitting live electrical current to enter the water. If the unit is dropped, unplug it and inspect the quartz sleeve for breakage or small cracks. Do not use until this inspection has been carried out.



### ELECTRICAL PRECAUTIONS

Always use a properly grounded outlet. Do not immerse the plug in water. **DO NOT REACH INTO THE WATER TO REMOVE THE PLUG. TURN OFF CIRCUIT FIRST.** A "drip loop" in the cords should be used. A "drip loop" is a loop in the cord below the level of the receptacle or plug that prevents water from traveling along the cord. The national Electric Code requires that a ground fault interrupter circuit (GFCI) be installed in every branch circuit supplying the fountain or pond equipment. Your dealer can supply GFCI units. **NEVER REMOVE GROUND PIN FROM PLUG.**

**WARNING: FOR YOUR PROTECTION, ALWAYS UNPLUG THE UNIT FROM ITS POWER SOURCE BEFORE INSTALLING OR SERVICING. DO NOT REACH, REMOVE OR DISASSEMBLE BEFORE YOU DISCONNECT POWER.**

# 1 OPTIONAL ACCESSORIES for use with your pressurized filter

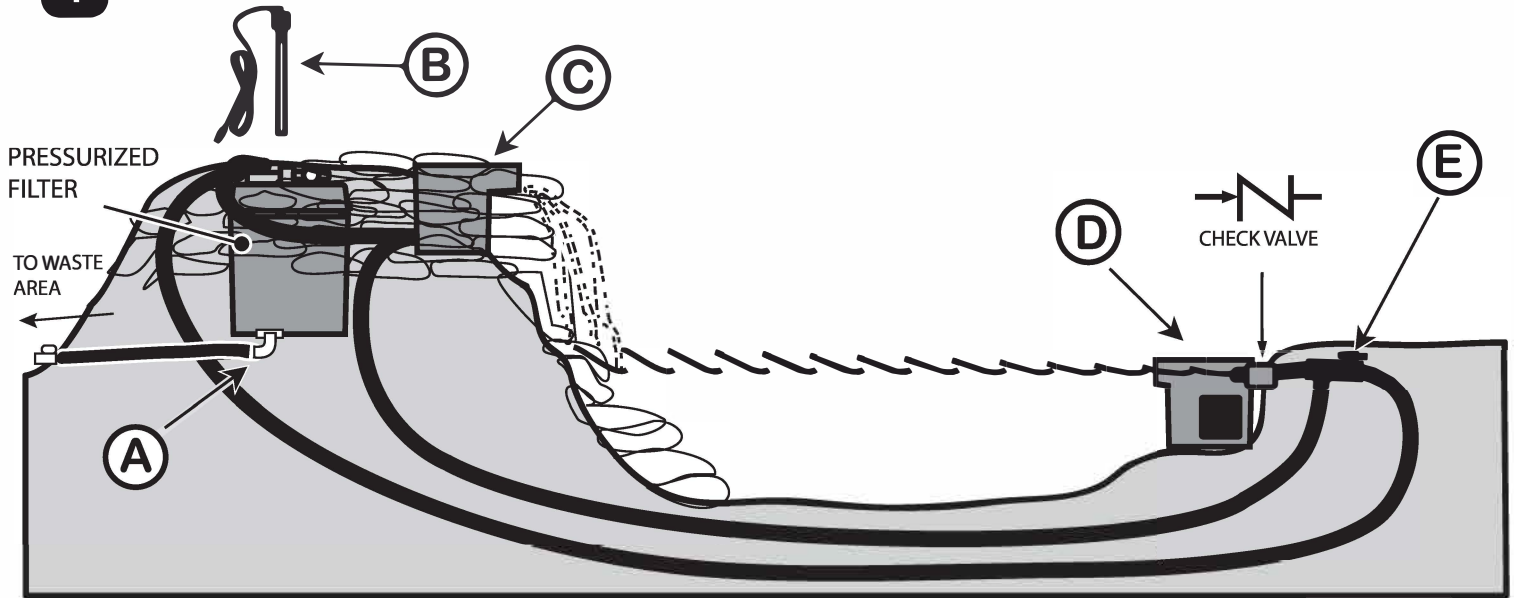

## (A) BOTTOM DRAIN (ITEM # 15010)

Pondmaster Pressurized Filters can be fitted with an optional bottom drain. Not to be confused with the backwash/rinse valve and hose used for weekly maintenance, the bottom drain is used to simplify annual winter maintenance by draining water from the bottom of the filter drum directly, without having to remove the water through the top -- either by siphoning or using a wet vac with a thin extension tube.

This accessory is strongly recommended and must be installed prior to setting up the filter.

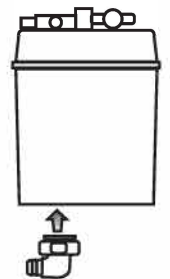

## (B) ULTRAVIOLET CLARIFIER (ITEM #'s 15210, 15220 & 15240)

The UV Clarifier uses ultraviolet to inhibit algae from reproducing by damaging its DNA. UV also kills parasites in the water. The effectiveness depends on variables such as flow rate and exposure rate to the UV rays. The UV Clarifier is included with the "PUV" designated filters only. It can easily be added at a later time to the other filters after set-up. Installation is through the cap in the agitator handle. Instructions are included.

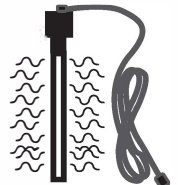

## (C) PRO BIOLOGICAL FILTER AND FALLS

PROLINE PRO1000, 2000, 3000 AND PRO 5000 BIO FILTER AND FALLS  
(ITEM #'s 02477, 02478, 02479, 02467, 02468, 02469, 02480, 02481, 02482, 02490 & 02492)

Produces a dramatic waterfall effect with extra wide spillway while providing extra filtration with flow through filter media and/or foam pads. Three sizes are available to make setting up a waterfall foolproof.

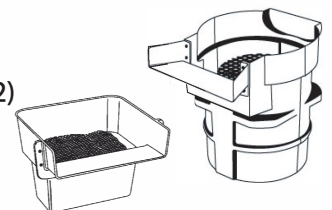

## (D) PRO SKIMMERS PROLINE 5000 SKIMMER AND MINI POND SKIMMER (ITEM #'s 02475 & 02450)

Provide an enclosure for the water pump and keep debris away from intake. Pro Skimmers have adjustable weir doors for maximum skimming with fish safe wings and removable leaf baskets. The Proline 5000 is perfect to handle the water flow demands of large ponds and the Mini Skimmer is suitable for use in smaller ponds.

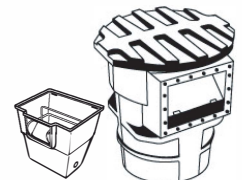

## (E) VALVED BYPASS (PROLINE Bypass kit ITEM # 15015)

Use to split and control water flow between the filter and a waterfall or fountain. Useful to prevent overburdening the low pressure filter without losing any water flow to the water feature.

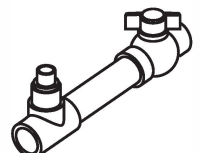

## 2 CHOOSE FILTER / PUMP LOCATION AND SELECT ACCESSORIES

This filter must be connected to an external water pump. The water pump can be submersible or above ground depending on your preference. Pondmaster makes several perfectly matched powerful pumps and accessories to complete your filter system. Please note the following:

- The intake for the water pump should be positioned at the opposite end of the pond from the water return.
- Pressure Filter should be as close as possible and slightly below the waterfall to reduce back pressure to the filter. Always avoid using a long hose between the Pressure Filter and the waterfall.
- Bury the filter drum to just below the pressure clamp. If positioned above ground, use the backfill from digging the pond to surround the filter drum.

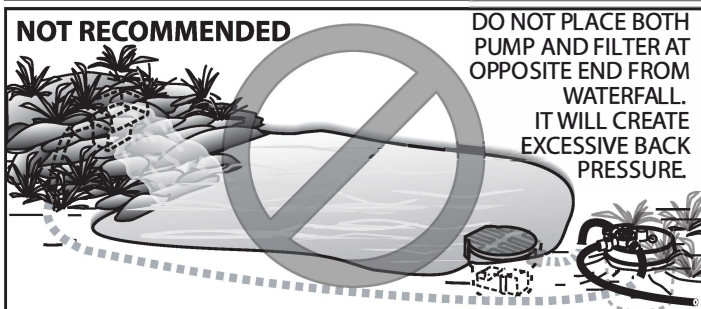
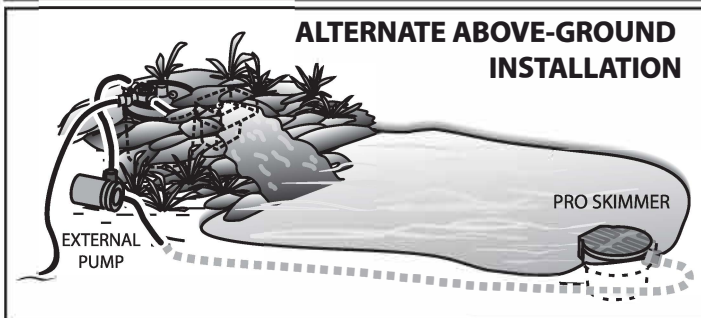
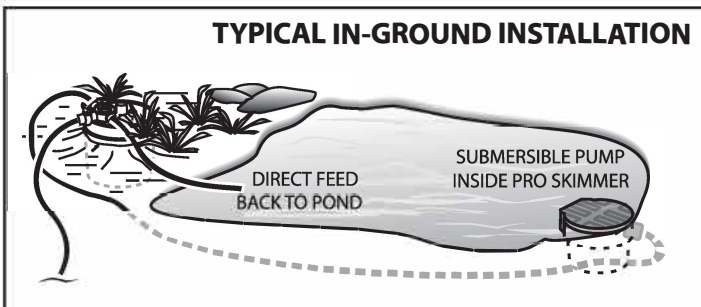
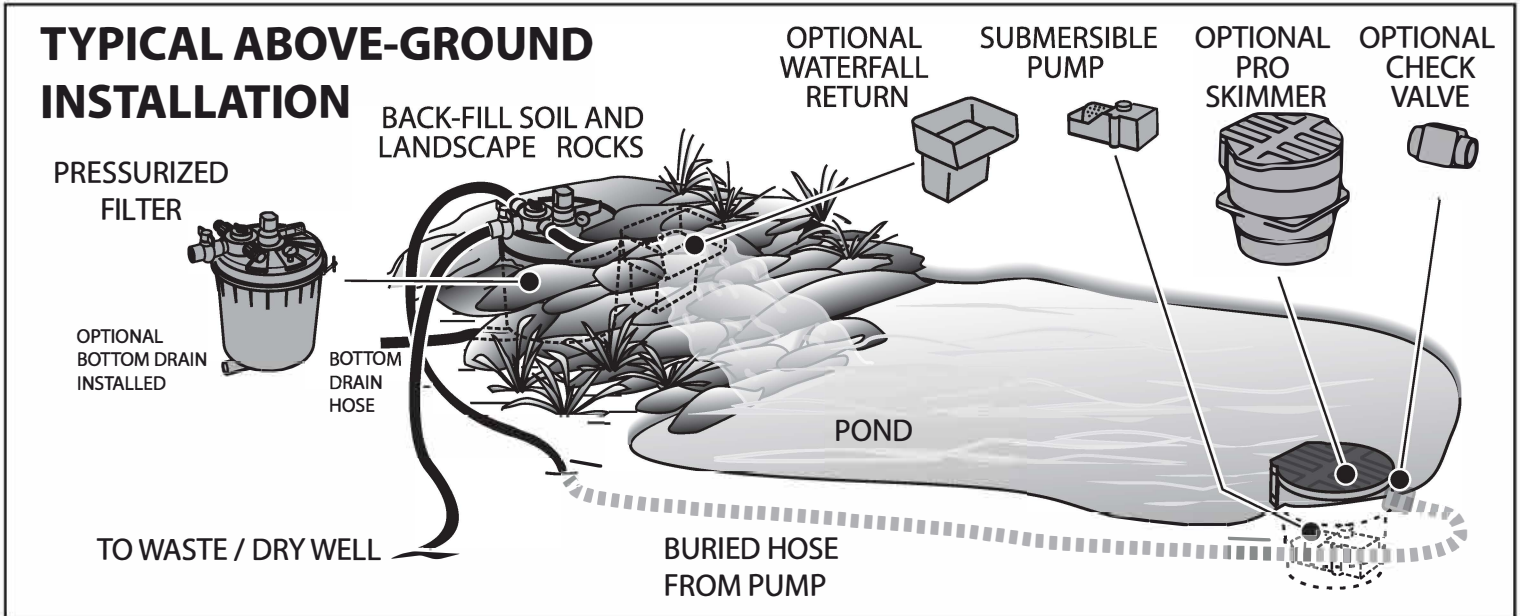

## 3 GATHER THE SUPPLIES NEEDED TO COMPLETE THE PROJECT

To set up the filter you will need the following items.

- Hoses -- 1 1/2" Flexible pressure hose (recommended). Note that a Valved Bypass must be incorporated into any high volume system (pumps over 4000 gallons per hour) or high pressure system (pumps that produce over 8 psi or 18' of head).
- Hose Clamps -- Stainless Steel, for each connection to pump and filter drain.
- Plumber's Teflon tape.
- In-Line Check Valve -- Prevents unintentional backwash in the event of a power loss. Must be sized to fit hose used between pump and filter.\*
- 1 1/2" male NPT x Barb adapter for attachment to waste valve.\*

\*Available at hardware stores, pool supply stores or irrigation supply centers.

OTHER SUPPLIES MAY BE NECESSARY DEPENDING ON WHICH OPTIONS AND ACCESSORIES YOU CHOOSE.

## 4 PUMP

## IMPORTANT INFORMATION!

### CHOOSING THE CORRECT PUMP

Your Pressurized Filter System works best within a certain range of flow and pressure. See Table below. Exceeding these values will cause leakage or breakage of the filter or its components and void the warranty.

PRESSURIZED FILTER	MAX PUMP OUTPUT (GALLONS/HOUR)	MAXIMUM BASELINE PRESSURE (P.S.I.) (See Step 7)	FOR POND SIZED (GALLONS)
P1000 or PUV1000	2000	5	Up to 1000
P2000 or PUV2000	2000	5	Up to 2000
P4000 or PUV4000	4000	5	Above 2000

NOTE: For water volumes above 4000 GPH, or pressures over 8 psi (18' head) a simple Valved Bypass will allow you to safely control exactly how much water and pressure goes into the Pressurized Filter and how much gets diverted to the water feature (waterfall or fountain for example). In all cases we recommend the use of 1 1/2" I.D. Hose to maximize flow rates while minimizing the back pressures.

We recommend the Pondmaster PM1200, PM1800 and PM2400 Pondmaster Mag Drive submersible pumps, our WFP2000 or the WFP3000 Waterfall Pumps or our 3200-XP and 4000-XP Pondmaster Pro HyDrive units. Note that the Pressure Filter comes with 1 1/2" Hose fittings. Be sure to check the fitting sizes on the pump you choose and pick up the necessary adapters.

## 5 FILTER AND HOSE ASSEMBLY

Unpack the Main filter unit. It is completely factory assembled and pressure tested. Do not open the cover.\*

If your filter includes the UV Clarifier, place it aside until after the filter is in its final mounted position. Directions for installation of the UV Clarifier are in Section 10.

\* **IMPORTANT NOTE:** If you do open cover, see section 9 on reassembly.

### ATTACH QUICK CONNECTS AND WASTE VALVE

Wrap external threads of Waste Port Multiport Valve with plumber's Teflon tape. Securely twist the Quick Connects and Waste Port Valve onto the Multiport Valve as shown. If the optional bottom drain is added, follow directions supplied with the bottom drain.

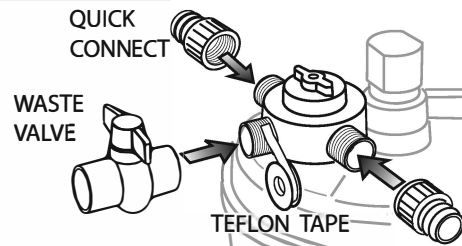

### NOTE

QUICK CONNECT ASSEMBLY ORDER

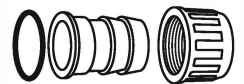

### ATTACH HOSES

Connect hoses from pump and to water return as shown using stainless steel hose clamps. We recommend using an in-line check valve before the PUMP connection.

Connect the waste water hose to the Waste Port Valve using a 1 1/2" male by insert adapter. Run the waste hose to a dry well or area where it will not flow back into the pond.

Helpful Hint: The nutrient rich waste water can be beneficial to feed garden plants.

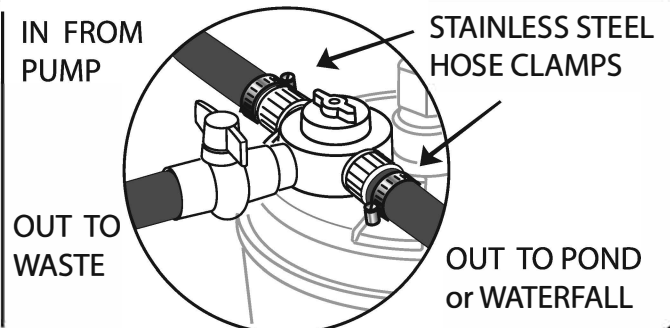

## 6 LEAK & FUNCTION TEST

- 1) The Waste Port Valve should be in the closed position.
- 2) Turn the Multiport Valve to the FILTER position.
- 3) Turn on the pump and check the hoses and clamps.

**After test, with pump running, Waste Port Valve must be open before operating the Clear Multiport Valve.**

### TOP VIEW OF CLEAR MULTIPORT VALVE WITH WASTEPORT VALVE

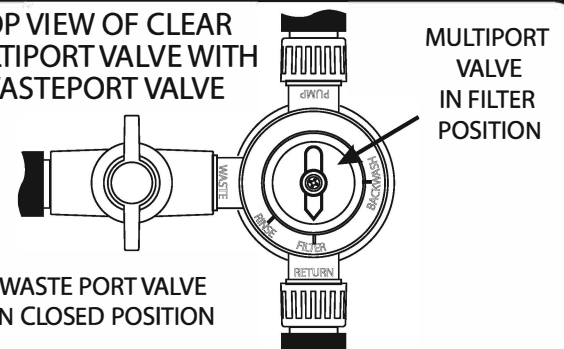

# 7 FILTER OPERATING INSTRUCTIONS

## VERY IMPORTANT INFORMATION ON HOW TO USE THIS FILTER.

Unlike other filters, this filter works **best** when the media is "dirty".

- 1) After initial setup the filter must be allowed to run **3 to 4 weeks untouched** in order to grow the bacterial colonies on the filter media that will biologically filter the water. During the first two weeks, the UV lamp should be turned off (unplugged).
- 2) When the waiting period has passed, turning the internal agitator backwashes and rinses out debris trapped by the colonies -- but only backwash **AFTER** the pressure begins to build.
- 3) The best way to tell when to backwash is to keep an eye on the pressure gauge.

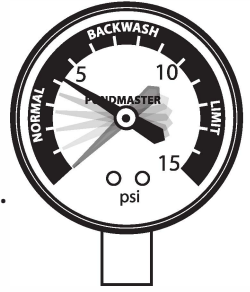

### BASELINE PRESSURE - USING THE PRESSURE GAUGE:

- 1) The Pressure Gauge will provide a reading immediately after the filter is set up and running. The psi will vary based on your particular setup. This is your **BASELINE**. **Write it here.**
- 2) Check weekly; when the pressure builds up to 2 to 3 psi ABOVE your BASELINE psi, it is time to agitate, backwash and rinse.
- 3) After backwashing the pressure will return to a reading close to the baseline reading.

RECORD BASELINE HERE

### HOW OFTEN SHOULD YOU BACKWASH? Check the Gauge...

Depending on organic load, the filter may not build up pressure for many weeks - *or even an entire season* - because it is metabolizing wastes as they enter. This means very few or no backwashes are needed. You should never have to backwash more than once per week. Remember, the filter works best when "dirty" so do not backwash unless necessary. See TROUBLESHOOTING if filter clogs up right away.

**NOTE: PRESSURE SHOULD NOT BUILD BEYOND 8 PSI. IF IT DOES, BACKWASH IMMEDIATELY TO LOWER PRESSURE AND PREVENT DAMAGE TO THE FILTER.**

**Then, determine the cause of excessive backpressure. It may be necessary to add a Valved Bypass.**

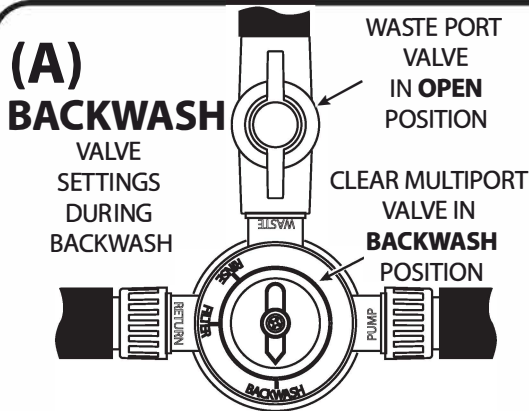

1. Open the WASTE PORT VALVE with the pump running.\*
2. Rotate the Multiport valve knob to the **BACKWASH** position.
3. Turn the agitator handle left to right and repeat approximately 10 times until water comes out of waste line nearly clear.
4. If the agitator handle becomes difficult to move, turn the Multiport valve to the **RINSE** position to clear the accumulated debris from the agitator mechanism. Then, return to the **BACKWASH** position and continue moving the handle to clear out the remaining debris.
5. Proceed to (B) **RINSE** step.



\* **Helpful Hint:** For smaller ponds or to minimize water loss during backwash cycle, turn off pump and agitate the media before step (A)-1 to loosen up accumulated debris inside filter. Then, start the backwash/rinse steps.

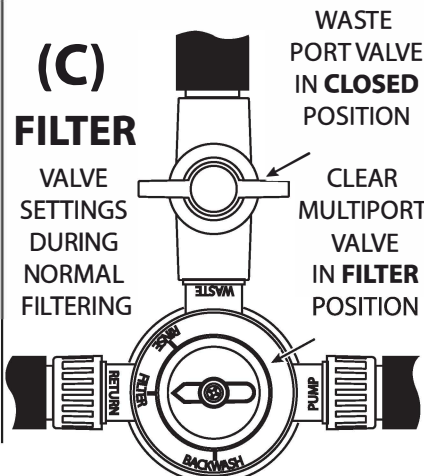
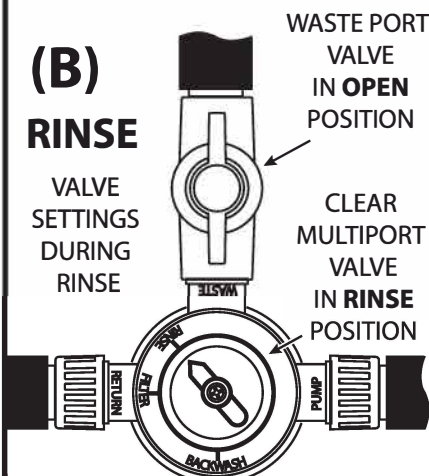

The **RINSE** operation works the same as the **BACKWASH** except the water goes through the filter in the opposite direction to help remove the rest of the debris inside the filter.

1. With the Waste Port Valve open, rotate the Multiport valve knob to the **RINSE** position (B).
2. Turn the agitator handle left to right approximately 10 times.
3. When the water comes out nearly clear, rotate the Multiport valve knob to the **FILTER** position, and then close the Waste Port Valve on the waste line to resume filtering (C). The gauge should drop by 2 - 3 psi -- close to the previously established baseline.



## 8 WINTERIZATION ..... WHERE NECESSARY

**CAUTION:** During harsh winters, water left in the drum may freeze, expand and crack the drum. If necessary, the filter can be drained and winterized at the end of the season. If you live in an area that doesn't experience freezing temperatures, you may never need to do this.

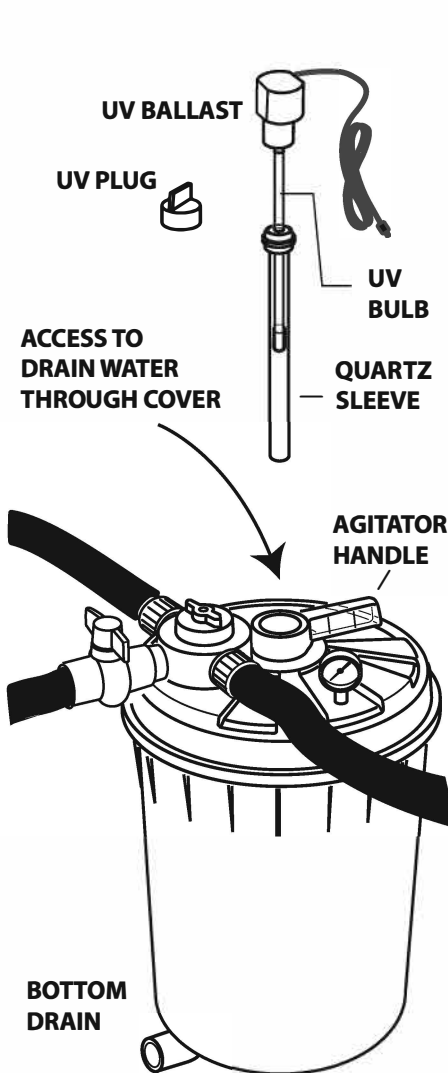

**To empty the water from the filter drum, it is not necessary to open the filter.**

- 1) Turn off the pump and disconnect the UV from the power source.
- 2) Turn the Waste port Valve to the open position and leave it open.
- 3) Remove the pressure gauge by unscrewing it.

**If you have installed a Bottom Drain,** open the valve for the Bottom Drain and leave open. Your Pressure Filter is now ready for winter.

**If you do not have a Bottom Drain,** it will be necessary to remove the water through the center opening of the Agitator handle.

**If your set-up has no UV Clarifier,** simply unscrew the UV Plug in the agitator handle to access the inside of the filter (See diagram.) Using a small "gas" siphon or a wet/dry shop vacuum with a thin extension tube will make emptying the drum easier. Reinstall UV Plug when finished.

**If your set-up includes a UV Clarifier,**

- A) With ballast disconnected from power source, unscrew the ballast by rotating it counter clockwise to remove it.
- B) Pull the ballast/light unit assembly straight up, being careful not to break the UV bulb. Disconnect bulb from ballast by carefully pulling the bulb and ballast straight apart. Put the ballast into storage.
- C) Remove the quartz sleeve for cleaning by gently pulling the quartz sleeve straight upward. Clean the quartz sleeve, then place bulb inside sleeve for safekeeping. Alternately, you may store sleeve and bulb in a safe place until ready for reassembly to ballast in the spring.
- D) Drain the filter with a small "gas" siphon or a wet/dry shop vacuum with a thin extension tube. Replace quartz sleeve and bulb in filter if desired.
- E) Screw UV Plug onto threads of tube adaptor in center opening of handle to keep rain water out.

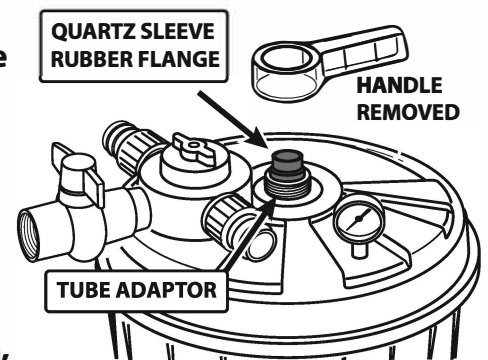

### IN THE SPRING...

Close Waste Valve and Bottom Drain where necessary. Reconnect hoses, reinstall Pressure Gauge and reassemble UV and ballast where applicable.

**CAUTION: DO NOT PLUG BALLAST INTO POWER SOURCE YET;** Start Pump and check for leaks. If applicable, UV ballast may now be plugged in to check for light THROUGH HANDLE - - NEVER LOOK DIRECTLY AT A THE BULB WHEN IT IS TURNED ON.

Please Note: the bulb produces useful UV radiation for 9000 hours, after which it must be replaced. For maximum performance, we recommend replacing the UV bulb annually.

**DISASSEMBLY:**

It should never be necessary to open the cover and disassemble the filter. Regular backwash and rinse maintenance will control the bacterial colonies inside the filter drum; bulb replacement of the UV Clarifier requires unscrewing the ballast from the top without removing the cover.

In the event that the filter must be opened, please follow all steps carefully.

- 1) Disconnect hoses from Clear Multiport Valve.
- 2) If the UV Clarifier is installed, remove it completely including the Quartz Sleeve. Refer to part 2 of section 8 Maintenance.
- 3) Remove the Stainless Steel Clamp by unscrewing Hex Nut.
- 4) Pull up from side to side, pop off the main cover and carefully pull straight up.

**DO NOT REMOVE THE MEDIA OR THE AGITATOR UNLESS IT IS ABSOLUTELY NECESSARY.**

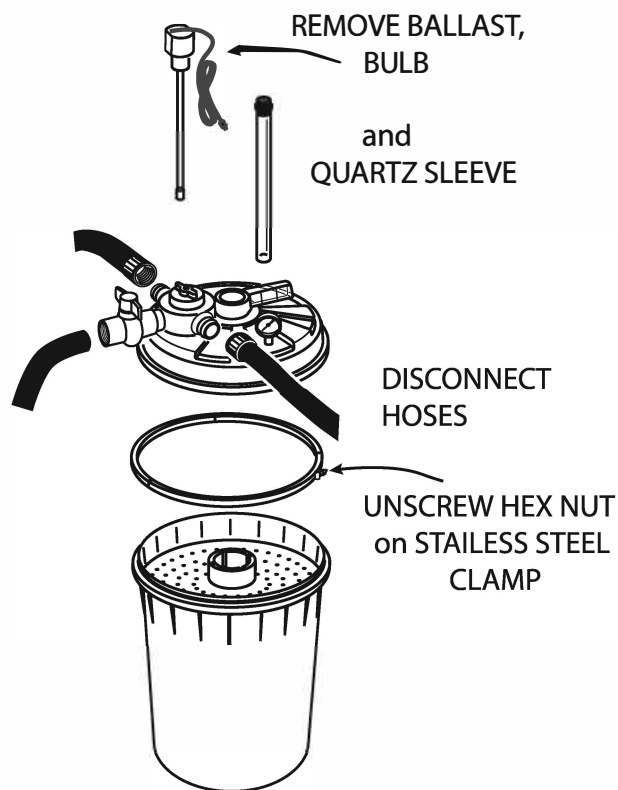

**REASSEMBLY:**

**1) If Agitator and Media were removed:** For best results place the Agitator back in BEFORE the Media is replaced. When refilling Drum with Media be careful not to let Media fall down into the Agitator Tube.

**2) If the Media is still in the Filter Drum:** Fill the Drum halfway with water. This allows the Agitator to turn easily. The Agitator can be reinstalled with the Media in the Drum by slowly rotating and pressing down. It will slowly seat itself down in the Media - - only if the Drum is partially filled with water.

**NOTE: It is usually necessary to get someone to help when replacing the Cover.**

**3)** Make sure the Drum, O-ring, Media Screen and rim of Cover are clean of all debris. Lubricate the O-ring sparingly with dish detergent.

**4)** With Media Screen in place inside Drum, place the Cover down until the Tube Adapter comes in contact with the Agitator Shaft. The Tube Adapter and Agitator Tube key together. Rotate the Cover until it drops down into place. Seat cover evenly around the Drum and push down.

**5)** Place the Stainless Steel Clamp around the filter assembly with the groove of the Clamp going over the rims of both the Cover and the Drum. Tighten the nut of the Clamp while lightly tapping all around on the Clamp with palm of hand or a rubber mallet until it is snug.

**6)** Reinsert the UV Clarifier as per instructions provided with it.

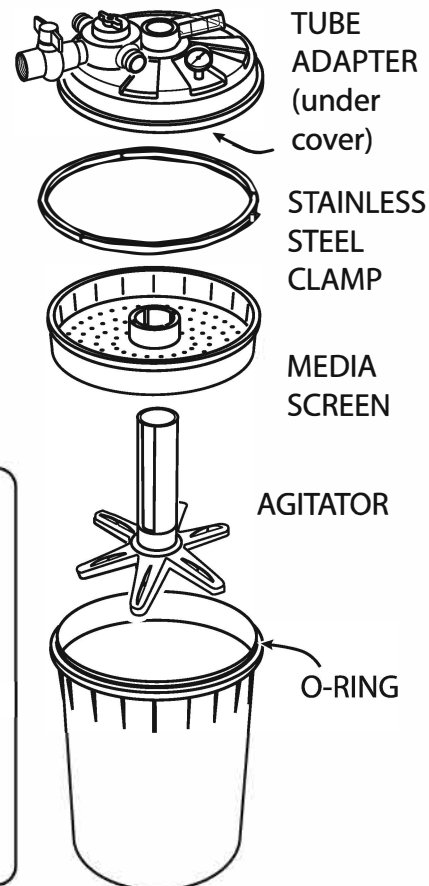

**IMPORTANT NOTE:** Drum will not close if ANY media is caught between Agitator and Drum or if Media Screen is not fully seated.

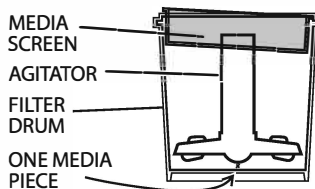

# 10 CARE AND OPERATING INSTRUCTIONS FOR UV CLARIFIER

WARNING! TURN OFF THE POWER BEFORE HANDLING OR SERVICING THE UNIT.  
DANGER! NEVER LOOK DIRECTLY AT THE LAMP RAYS.

The UV lamp and quartz sleeve are not installed and are located in separate boxes inside the main carton. When handling the UV lamp, do not touch the glass bulb. Either hold the ceramic ends or, preferably, wear gloves. To install the UV lamp, align the center slot and pins with the mating connector inside the transformer (photo #1) and push the lamp firmly (photo #2). To install the quartz sleeve, insert the closed round end into the tube adapter (photo #3) until the rubber gasket is all the way down in the adapter. A flange will prevent the ring from going any further and it will rest against the tube adapter.

1.



Note that a micro-switch in the ballast cuts off power to bulb when disassembled.

2.

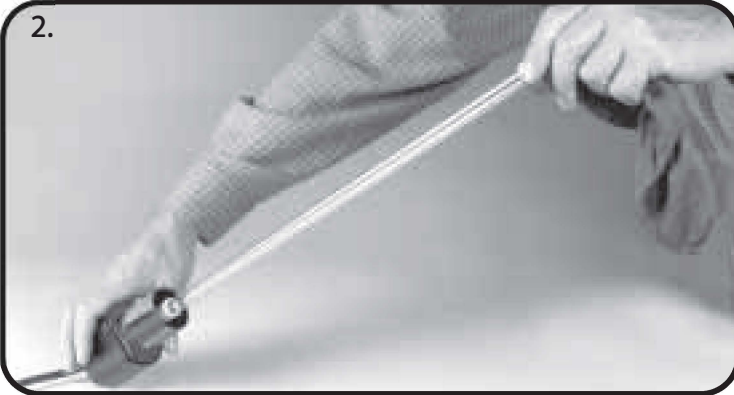

3.



4.



Place the agitator handle over the tube adapter and slide the lamp and transformer into the quartz sleeve. Lightly hand-tighten the transformer into the tube adapter (photo #4). **DO NOT OVER-TIGHTEN.**

Quartz Sleeve should be cleaned periodically for best performance. Dirt and lime scale build-up will block the UV light and reduce its efficiency. To remove the sleeve for cleaning, take hold of the sleeve and pull it straight upwards. Clean the quartz tube with vinegar and scrub pad.

Always check the rubber gasket attached to the top of the quartz tube. If it is worn or gouged, it may not seal properly and prevent light from working.

**PLEASE NOTE that the clear plastic parts on the filter transmit visible light only, which is safe to look at. This indicates that the unit is working, however, the lamp will produce visible light long after it has stopped producing effective UV light. For the best performance, the lamp should be replaced every year because it slowly degrades with use.**

# 11 TROUBLESHOOTING

**General Note: Avoid opening filter cover. Most problems can be corrected without accessing the interior of the filter.**

PROBLEM	POSSIBLE CAUSE	SOLUTION
Filter output is sluggish.	Media needs backwashing.	Backwash filter. See section 7.
	Pump intake is clogged.	Check pump and clear debris. Use a Pump Bag around pump to prevent future clogging.
	Pump requires maintenance.	See pump manual.
	Discharge is clogged.	Remove blockage from discharge
Filter Clogs right away.	Pressure Filter is clogged with leaves or large debris. Pond has too much waterborne debris.	Remove large debris with a net and prevent future clogging by installing a ProSkimmer.
		Use a Pump Bag
	Cracked Pump Screen or faulty prefilter on pump.	Never use the filter as a "Vacuum". For a pond with a lot of debris use or rent a pond vac.
		Replace or repair pump accessory. Use a Pump Bag
Pressure Gauge reads less than 1 psi.	Filter has no active bacterial colonies yet.	Gauge should not show back pressure until it needs backwashing. Check weekly.
	Pump is too small.	Replace with a recommended pump.
	Gauge is malfunctioning.	Test by VERY slowly turning valve towards "Backwash" with waste valve CLOSED. Pressure rise should show on gauge. <b>CAUTION:</b> Return valve to "Filter" position as pressure gauge rises, or damage to filter may result. Replace Gauge if needed.
Agitator handle is difficult to turn or immovable.	Pressure lock-up.	Turn off pump before moving handle. Proceed to Backwash.
	Quartz Sleeve may have broken or there is debris under agitator shaft.	Disconnect power to the UV and turn off the pump. Remove UV Ballast with the UV Light Bulb and check if the Quartz Sleeve is broken (there will be water inside the sleeve). If so, remove old Quartz Sleeve and debris and replace with a new one. (See instruction's section on Disassembly / Reassembly).
	The Agitator Handle is blocked by debris on the cover.	There may be a piece of debris trapped under the agitator handle. Remove UV unit, or UV plug then lift handle, clear debris and reassemble.
Agitator handle moves freely without turning agitator.	Handle is split at tubing adapter connection or tube adapter is broken.	Remove handle, clear debris and reassemble.
		Replace handle -or- entire cover - if tubing adapter is broken.
Filter drum is leaking at perimeter.	Clamp is loose or misaligned	Make sure clamp is sitting evenly over both top and bottom flanges all the way around the drum. Tighten if necessary.
	Pressure is too high.	Pump is too large. Install a Valved Bypass to redirect excessive water pressure buildup. Water can be diverted directly to your waterfall.
	O-ring is nicked or torn.	Replace O-ring. See section on filter disassembly and re-assembly.
	O-ring, Cover and/ or drum flanges have grit or debris on them.	Inspect and meticulously clean off all debris. Very carefully re-attach all parts. See section on filter disassembly and re-assembly.
Multiport Valve is difficult to turn or immovable.	There may be debris in Multi-port Valve.	Turn off water flow. Remove the eight screws holding the Multi port Valve and clear debris. Re-attach valve gasket and screws.

# 12 PARTS and ACCESSORIES

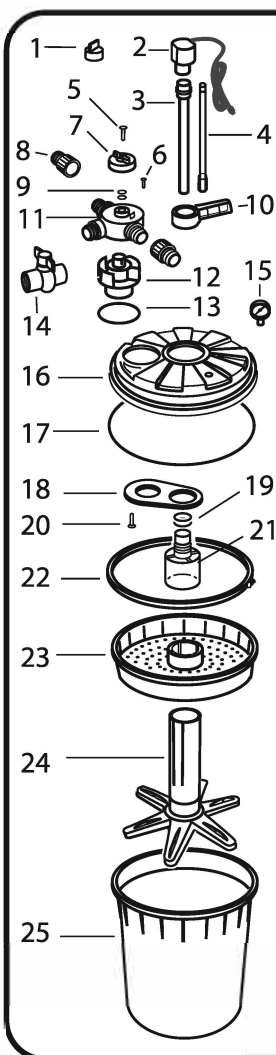

## PARTS LIST

#	Description
1	UV Plug
2	Ballast
3	Quartz Sleeve
4	UV Bulb
5	Multi Port Valve Center Screw
6	Multi Port Valve Flange Screws
7	Multi Port Valve Knob
8	Quick Connect
9	Multi Port Valve Knob O-rings
10	Agitator Handle
11	Multi Port Valve Housing
12	Multi Port Valve Gate
13	Multi Port Valve Bottom O-ring
14	Waste Port Valve
15	Pressure Gauge
16	Cover
17	Cover/Drum O-ring
18	Valve Cover
19	Tube Adaptor O-rings
20	Valve Cover Screw
21	Tube Adapter
22	Stainless Steel Clamp
23	Screen
24	Agitator Tube Assembly
25	Drum
26	Bio-Matrix Filter Media (Not Shown)

### WARRANTY

Pondmaster Filtration systems are warranted against failure due to defects in materials and/or workmanship for one year from date of purchase. This warranty covers defects occurring under normal use and applies to the original purchaser at retail and may not be transferred. The warranty and remedies set forth herein are conditional upon proper installation, use, maintenance, storage, and conformance with the applicable use. It will be based upon Danner Mfg. discretion as to whether the defects are of manufacturing origin. Any damages due to improper installation are not covered by this warranty. This warranty does not apply to appearance or accessory items. This warranty does not include damage due to handling, transportation, unpacking, setup, installation, repair or replacement of parts supplied by any other than Danner Mfg.; improper maintenance, modification or repairs by the purchaser; abuse, misuse, neglect, accident, fire, flood, or other acts of God. Any oral statements about this product made by the seller, the manufacturer, their representatives or any other parties do not constitute warranties and shall not be relied upon by the user and are not part of this contract. Neither the seller nor the manufacturer shall be liable for any injury, loss or damages, direct, incidental, or consequential, including but not limited to incidental or consequential damage for lost profits, lost sales, injury, and inability to use the product and the user agrees that no other remedy is available. Before using, the user shall determine the suitability of the product for their intended use and the user shall assume all risk liability whatsoever in connection therewith. To validate this warranty, keep your proof of purchase (copy of sales receipt). Warranty covers the repair or prorated replacement of the Danner Mfg. products. Danner Mfg. denies all liability for any other loss including but not limited to loss of equipment, income, livestock, or personal injury.

**THE FOLLOWING VOIDS WARRANTY: PRODUCT LABELS ARE DEFAUCED OR REMOVED. PRODUCT IS IMPROPERLY INSTALLED OR MAINTAINED BY USER OR THEIR AGENT. PRODUCT IS ABUSED, MISUSED, OR DAMAGED BY USER OR THEIR AGENT. PRODUCT DAMAGE IS CAUSED BY OVER-TIGHTENING FITTINGS ON VALVE PORTS. USING ANY SEALANT OTHER THAN TEFLON TAPE ON THE VALVE. USE OF HIGH PRESSURE PUMP WITHOUT UTILIZING A PROPERLY INSTALLED VALVED BYPASS.**

## REPLACEMENT PARTS

CAT #	Description	Includes Parts	Fits Models
15060	UV Plug	(1)	All
15115	Quick Connect	(8)	All
15020	O-ring set	(9,13,17,19)	All
15025	Pressure Gauge	(15)	All
15030	Multiport Valve	(9,11,12,13)	All
12927	Waste Port Valve	(14)	All
15050	Agitator Handle	(10)	All
15055	Shaft Adaptor	(19,21)	All
15040	Clamp	(22)	All
12971	10W UV Bulb	(4)	# 05015 PUV-1000
12972	20W UV Bulb	(4)	# 05025 PUV-2000
12974	40W UV Bulb	(4)	#05045 PUV-4000
12981	10W Quartz Sleeve	(3)	#05015 PUV-1000
12982	20W Quartz Sleeve	(3)	# 05025 PUV-2000
12984	40W Quartz Sleeve	(3)	#05045 PUV-4000
12991	10W Ballast	(2)	# 05015 PUV-1000
12992	20W Ballast	(2)	# 05025 PUV-2000
12996	40W Ballast	(2)	#05045 PUV-4000
12200	BioMatrix Media	(Not shown)	All
05099	Cover (Assembly)	(1,5 - 7,9 - 13, 16- 21)	All
15075	Small Drum	(25) 13" height	# 05015 PUV-1000 # 05025 PUV-2000
15070	Large Drum	(25) 19" height	# 05045 PUV-4000

## ACCESSORIES

CAT #	Description	Fits Models
15010	Bottom Drain Kit	All
15210	10W UV Adapter Kit	# 05015 / PUV-1000
15220	20W UV Adapter Kit	# 05025 / PUV-2000
15240	40W UV Adapter Kit	# 05045 / PUV-4000
15015	Valved Bypass Kit	All