

PUMP PARTS REFERENCE

1.9 Magnetic Drive Pump	
#	Description
1	Motor*
2	Impeller Assembly
3	Cover w/ O-Ring & Flow control
4	Non-Threaded Elbow*
5	Screw set*
6	Filter Pad
7	Filter Cover

***NOTE:**
Parts with asterisk (*) are listed here for reference only and may not be available.

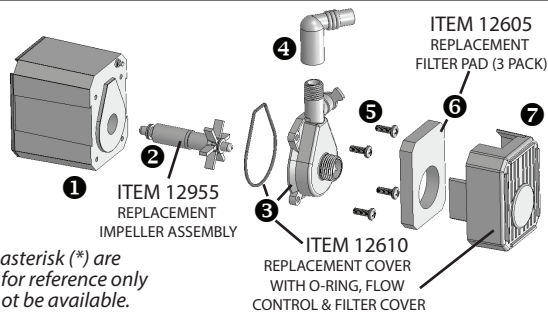

Danner Magnetic Drive Pump for Submersible or In-Line use

SAVE THESE INSTRUCTIONS

CARE AND OPERATING INSTRUCTIONS

Model 1.9
ITEM # 02519
ITEM # 40120

Model 1.9 Pump With filter
ITEM # 02019

Model 1.9 Pump
With Fountain & Block Foam Filter
ITEM # 02273

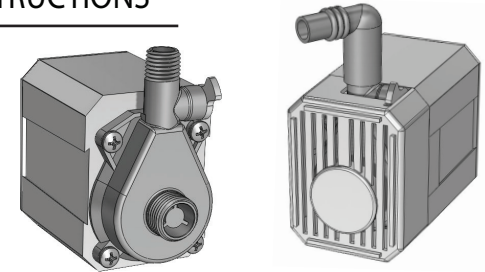

Shown with and without pre-filter cover and elbow adapter

**WARNING!! PONDS ARE DANGEROUS TO SMALL CHILDREN!
NEVER LEAVE CHILDREN UNSUPERVISED NEAR A POND**

INTRODUCTION

Thank you for purchasing this Danner water pump. This submersible or in-line pump provides a continuous stream of water with an adjustable flow control. Danner pumps are carefully inspected and tested to insure both safety and operating performance. However, failure to follow the instructions and warnings in this manual may result in pump damage and/or serious injury. Be sure to read and save this manual for future reference.

The Model 1.9 pump has a number of features which make it versatile. A 1/2" inside diameter tube may be slipped over the outlet or a 1/4" pipe thread fitting can be used. The pump also comes with an elbow which will accept 3/8" ID tubing or a 1/2" ID soft tubing. The elbow is for submersible use only. The elbow directs the soft tubing horizontally to prevent kinks. When there is limited room in the base of statuary, the pump can be placed with the screen inlet down for operation in shallow water.

The kits that utilize the 190 pump both include filtration media and a bell shaped fountain. The filter media keep the water clean and protect the pump. In most set-ups they can be rinsed and re-used several times before needing replacement.

ELECTRICAL PRECAUTIONS

Always use a properly grounded outlet. Do not immerse plug in water. **DO NOT REACH INTO WATER TO REMOVE PLUG. TURN OFF CIRCUIT FIRST.** A "drip loop" should be provided. The "drip loop" is a loop in the line cord below the level of the receptacle or plug that prevents water from running along the cord. The National Electric Code requires that a ground fault circuit interrupter (GFCI) be installed on the branch circuit supplying fountain or pond equipment. Your dealer can supply GFCI units. **NEVER REMOVE THE GROUND PIN FROM PLUG. WARNING: FOR YOUR PROTECTION ALWAYS UNPLUG THE UNIT FROM ITS POWER SOURCE BEFORE INSTALLING OR SERVICING. SHOULD THE UNIT APPEAR TO BE NOT WORKING DO NOT REACH, REMOVE OR DISASSEMBLE UNIT BEFORE YOU DISCONNECT POWER.** The pump is intended to pump water only. It cannot be used to pump oils, solvents or gasoline.

02019 POND FILTER

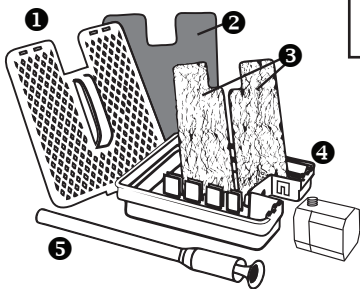

ITEM # 12195
Filter pad replacement pack for Garden Pond Filter includes:
2 Foam Filter 1 pc
3 Fiber Filters 2 pcs

FILTER & FOUNTAIN PARTS REFERENCE

#	Description
1	Filter Cover*
2	Foam Filter
3	Fiber Filters
4	Filter Bottom*
5	Bell Fountain*
6	Bell Fountain*
7	Foam Block

***NOTE:**
Parts with asterisk (*) are listed here for reference only and may not be available.

02273 BELL FOUNTAIN

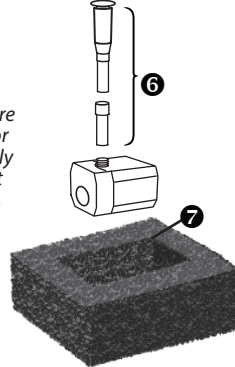

ITEM # 12600
Replacement foam block for Bell Fountain includes:
7 Foam Block 1 pc

LIMITED WARRANTY

Danner pumps are warranted against failure due to defects in materials and/or workmanship for 5 years from date of purchase. This warranty covers defects occurring under normal use. The warranty and remedies set forth herein are conditional upon proper installation, use, maintenance, storage, and conformance with the applicable use. It will be based upon Danner Mfg. discretion as to whether the defects are of manufacturing origin. For warranty repair, return only the part that is defective to our factory. Please include a dated proof of purchase and \$5.00 for postage and handling. Any damages due to improper installation are not covered by this warranty. This warranty does not apply to appearance or accessory items. This warranty does not include damage due to handling, transportation, unpacking, setup, installation, repair or replacement of parts supplied by any other than Danner Mfg.; improper maintenance, modification or repairs by the purchaser; abuse, misuse, neglect, accident, fire, flood, or other acts of God. Any oral statements about this product made by the seller, the manufacturer, their representatives or any other parties do not constitute warranties and shall not be relied upon by the user and are not part of this contract. Neither the seller nor the manufacturer shall be liable for any injury, loss or damages, direct, incidental, or consequential, including but not limited to incidental or consequential damage for lost profits, lost sales, injury, and inability to use the product and the user agrees that no other remedy is available. Before using, the user shall determine the suitability of the product for their intended use and the user shall assume all risk liability whatsoever in connection therewith. To validate this warranty, keep your proof of purchase (copy of sales receipt). Warranty covers the repair or prorated replacement of the Danner Mfg. products. Danner Mfg. denies all liability for any other loss including but not limited to loss of equipment, income, livestock, or personal injury. THE FOLLOWING VOIDS WARRANTY: LINE CORD OR PLUG IS ALTERED OR CUT, PRODUCT LABELS ARE DEFACED OR REMOVED. PRODUCT IS IMPROPERLY INSTALLED OR MAINTAINED BY USER OR THEIR AGENT. PRODUCT IS ABUSED, MISUSED, OR DAMAGED BY USER OR THEIR AGENT. PRODUCT IS NOT REMOVED FROM SERVICE AND DRIED DURING FREEZING CONDITIONS.

E G Danner Mfg. Inc. 160 Oval Drive Islandia, NY 11749

TEL: 631-234-5261 or 800-458-5876 Website: www.dannermfg.com



Subscribe to our YouTube Channel and view all of our product videos.

PUMP OPERATION

Centrifugal pumps will not pump if the housing is filled with air. The inlet must be filled with water. Unless the air can escape from the outlet, the pump will not pump water.

The pump included with the Pondmaster 190 will pump up to 190 gallons per hour. If you chose not to use the Bell Fountain head, a 1/2" ID tubing will fit over the nozzle. This can power a statue or waterfall. NOTE: There are a number of things which will reduce the flow of a pump:

- Dirty or clogged filter.
- Small diameter hose (do not use a 1/2" ID hose over 6' long).
- FLOW THROUGH 15' OF 1/2" FLEX TUBING IS REDUCED TO less than 160 GPH @ ZERO HEAD.
- The height the water is pumped. (measured from the pond surface to the hose discharge).
- If you must connect to a small fitting on a statue, reduce the size of the hose at the statue, not at the pump end of the hose.

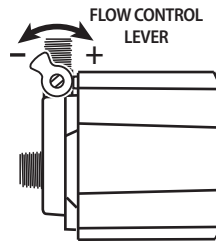
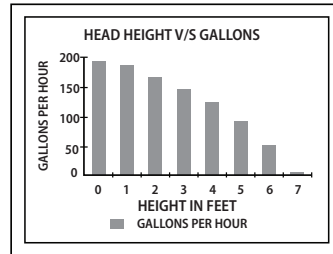

INLINE USE

The 1.9 pump is suitable for inline use by following these precautions:

- Do not use non-threaded elbow for inline applications.
- Use several wraps of Teflon tape (Not included) on all threaded fittings. (A)
- Do NOT overtighten threaded adapters.*1
- Leave a gap above the Flow Control Lever. (B)
- Always check inline set-up for leakage before leaving unattended.

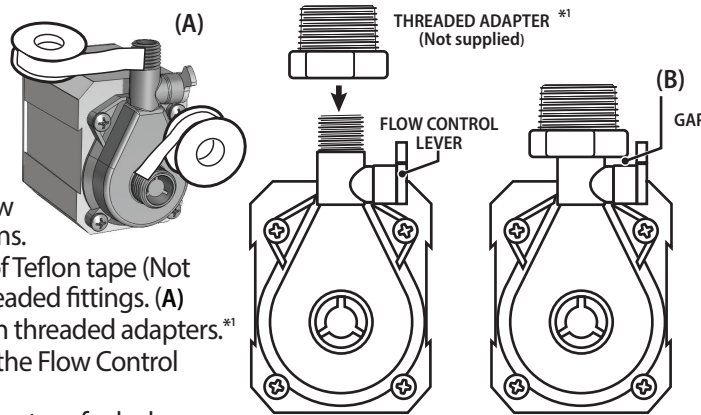

*1 Hand tightening should be sufficient. Using a wrench may "bottom-out" and over-stress the plastic volute.

PMK 190 FILTER KIT

The 1.9 pump (with the filter cover and filter pad removed) slides into the dovetail tracks in the filter plate. The filter plate can be guided into the middle of the pond by tying a line to the filter handle. The tie line is also useful to remove the filter for service; do not pull on the power cord. Replace elbow with the bell fountain head to beautify your set-up as well as control spray and splashing.

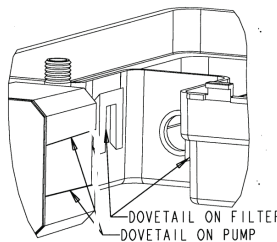

FOUNTAIN KIT

Place entire 1.9 pump into foam block and insert fountain assembly onto pump spout.

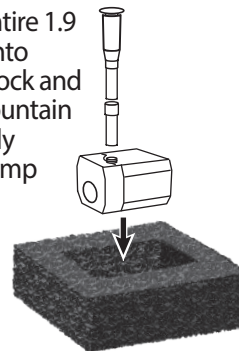

OPERATING TIP for 02019 filter

In some ponds, as the water is filtered, dissolved gases will separate out of the pond water during the filtering process. This may make the filter float to the surface as the gases collect in the filter box. We recommend that a few small pieces of slate or flat stones be placed in the lower base of the filter by removing the cover and filter media from the compartment and placing the weights into the base.

MAINTENANCE - FILTER and FOAM BLOCK

To service filter media, disconnect power to pump and pull the filter from the pond using the handle on filter (not line cord). Lift the tab on the side opposite the pump, lift the handle and slide the cover toward the pump to disengage from housing. For foam block simply lift pump up from foam cavity.

Keep in mind that phosphates which are present in many water supplies, joined with the increased biological load present in most man made ponds make an ideal breeding ground for algae. Decreasing the amount of bright sunlight your pond is exposed to and eliminating overfeeding of pond fish are two ways to help regulate algae growth. No mechanical filtering system alone will eliminate algae growth.

All filter media can be easily removed from filter and quickly rinsed. If you wish to maintain the biological filter bed do not soak or wash filter pads in chlorinated water. Use water from the pond. When the pads start to mat down or if the foam block flakes or tears, it should be replaced.

MAINTENANCE - PUMP

Periodically the pump will need to be cleaned when the flow slows down or stops. To clean, unplug and remove from water. Slip off pre-filter cover and wash out the foam pre-filter pad. After repeated washings the foam will need to be replaced.

After a period of time deposits may build up inside the pump cover. Remove the four screws which hold the pump cover to the motor housing and pull cover straight away from the pump body. **Pulling on an angle will stress and break the ceramic impeller shaft.** The impeller is the only serviceable item. It can be cleaned or replaced. If it is worn or broken the entire impeller assembly can be replaced. This will restore the pump to original capacity. Do not overtighten screws when assembling. Check that O-ring is seated into groove in pump cover. If pump fails to start recheck that impeller is not blocked by debris. For best results the minimum water level depth should be 2 inches. Pumps taken out of service with the fluid inside run the risk of forming a crust which may prevent subsequent starting. Magnet impeller assembly must be routinely cleaned to remove accumulations of scale or calcium. This procedure should be done at least once every three months - or more often if the water conditions require it. Salt water and hard water environments require more frequent cleaning.

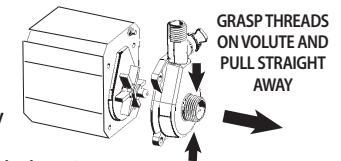

PUMPGUARD™ maintenance INSTRUCTIONS

- 1) DISCONNECT POWER TO PUMP.
- 2) REMOVE PUMP FROM WATER.
- 3) POSITION PUMP WITH VOLUTE INLET FACING UPWARDS.
- 4) POUR PUMPGUARD INTO VOLUTE INLET UNTIL FULL.
- 5) ALLOW TO SOAK FOR 2 TO 3 MINUTES.
- 6) THOROUGHLY RINSE WITH CLEAN WATER.
- 7) PLACE PUMP BACK INTO SERVICE.

PUMPGUARD™ is available in three sizes:
 4 oz. - Impeller /Volute treatment ----- ITEM # 03905
 32 oz. - Soak/Dunk impeller treatment ---ITEM # 03907
 128 oz. - Commercial Size ----- ITEM # 03909