



DARKSIDE
BICYCLES

STAND OUT FROM THE CROWD

BICYCLE USER MANUAL

THANK YOU FOR YOUR TRUST!

...and congratulation on your new bicycle. Your Darkside bike has been designed and manufactured with the utmost passion and care. Proper assembly and operation of your bicycle is important for your safety and enjoyment.

If you have questions or need advice regarding assembly, parts, performance, or returns, **please contact the us.**

Enjoy the ride & ride safe at all times!

Customer Service hours:	Monday - Friday 10 am - 5 pm CET
Phone:	please see www.darksidebicycles.com
Email:	service@darksidebicycles.com
Mail:	DSB Evolution GmbH Boveristraße 30 - 34 68309 Mannheim, Germany

This page has been left blank intentionally.

IMPORTANT

This manual contains important safety, performance and service information. Read it before you take the first ride on your new bicycle, and keep it for reference.

Most of the provided information in this manual is universally written to apply to different bike models.

Additional safety, performance and service information for specific components such as pedals on your bicycle, or for accessories such as helmets or lights that you purchase, may also be available. Make sure that your dealer has given you all the manufacturers' literature that was included with your bicycle or accessories. In case of a conflict between the instructions in this manual and information provided by a component manufacturer, always follow the component manufacturer's instructions.

If you have any questions or do not understand something, take responsibility for your safety and consult Darkside customer service or your dealer.

NOTE: *This manual is not intended as a comprehensive use, service, repair or maintenance manual. In case of questions, contact Darkside customer support. Please see your local bicycle dealer / professional bicycle mechanic for all service, repairs or maintenance. Your local bicycle dealer may also be able to refer you to classes, clinics or books on bicycle use, service, repair or maintenance.*

WARNING

For your own safety, never do any work on your bike, unless you feel absolutely sure about it. If you are unsure about anything, contact Darkside customer service!

WARNING

When using the bicycle on public roads, your bicycle must be equipped in accordance with the state regulations (for Germany see StVO). In the delivery state, your bike does not meet the requirements of the StVO. It is your responsibility to equip the bicycle accordingly.

TABLE OF CONTENT

GENERAL WARNING	1		5	SERVICE	25
A SPECIAL NOTE FOR PARENTS	2		5.1	SERVICE INTERVALS.....	25
1 FIRST	3		5.2	IF YOUR BICYCLE SUSTAINS AN IMPACT.....	27
1.1 BIKE FIT.....	3		6	PARTS IDENTIFICATION	28
1.2 SAFETY FIRST.....	3		7	ASSEMBLY	29
1.3 MECHANICAL SAFETY CHECK.....	3		7.1	TOOLS REQUIRED.....	29
1.4 FIRST RIDE.....	5		7.2	GETTING STARTED.....	29
2 SAFETY	6		7.3	INCLUDED BICYCLE PARTS.....	30
2.1 THE BASICS.....	6		7.4	ATTACH THE CARBON SEAT POST.....	30
2.2 RIDING SAFETY.....	6		7.5	PLACING THE BICYCLE IN A WORK STAND.....	32
2.3 OFF ROAD SAFETY.....	7		7.6	ATTACH THE FRONT WHEEL.....	32
2.4 WET WEATHER RIDING.....	8		7.7	ATTACH THE HANDLEBAR.....	33
2.5 NIGHT RIDING.....	8		7.8	ATTACH THE PEDALS.....	35
2.6 RACING OR COMPETITION.....	9			APPENDIX	36
2.7 EXTREM OR STUNT RIDING.....	10			APPENDIX A - INTENDED USE OF YOUR BICYCLE.....	36
2.8 CHANGING COMPONENTS OR ADDING ACCESSORIES.....	10			APPENDIX B - THE LIFESPAN OF YOUR BICYCLE.....	38
2.9 AEROBAR.....	10		1.	NOTHING LASTS FOREVER, INCLUDING YOUR BIKE.....	38
3 FIT	11		2.	PERSPECTIVE.....	38
3.1 STANDOVER HEIGHT.....	11		2.1	Understanding Metals.....	38
3.2 SADDLE POSITION.....	11		2.2	Understanding Composites (Carbon Fiber).....	41
3.3 HANDLEBAR HEIGHT & ANGLE.....	13		2.3	Inspection of Composite Frame, Fork, & Components.....	42
3.4 CONTROL POSITION ADJUSTMENT.....	14		2.4	Understanding Components.....	42
3.5 BRAKE REACH.....	14			APPENDIX C – TORQUE SPECIFICATIONS.....	43
4 TECHNOLOGY	15			APPENDIX D – PURCHASE RECORD.....	45
4.1 WHEELS.....	15			APPENDIX E – WARRANTY AND GUARANTEE.....	46
4.2 BRAKES.....	20		1.	ACTIVATE YOUR BICYCLE GUARANTEE.....	47
4.3 PEDALS.....	22				
4.4 TIRES & TUBES.....	23				

GENERAL WARNING

Like any sport, bicycling involves risk of injury and damage. By choosing to ride a bicycle, you assume the responsibility for that risk, so you need to know — and to practice — the rules of safe and responsible riding and of proper use and maintenance. Proper use and maintenance of your bicycle reduces risk of injury.

This Manual contains many “Warnings” and “Cautions” concerning the consequences of failure to maintain or inspect your bicycle and of failure to follow safe cycling practices.

The combination of the safety alert symbol  and the word **WARNING** indicates a potentially hazardous situation which, if not avoided, could result in serious injury or death.

The combination of the safety alert symbol  and the word **CAUTION** indicates a potentially hazardous situation which, if not avoided, may result in minor or moderate injury, or is an alert against unsafe practices.

The word CAUTION used without the safety alert symbol indicates a situation which, if not avoided, could result in serious damage to the bicycle or the voiding of your warranty.

Many of the Warnings and Cautions say “you may lose control and fall”. Because any fall can result in serious injury or even death, we do not always repeat the warning of possible injury or death.

Because it is impossible to anticipate every situation or condition which can occur while riding, this Manual makes no representation about the safe use of the bicycle under all conditions. There are risks associated with the use of any bicycle which cannot be predicted or avoided, and which are the sole responsibility of the rider.

This page has been left blank intentionally.

A SPECIAL NOTE FOR PARENTS

As a parent or guardian, you are responsible for the activities and safety of your minor child, and that includes making sure that the bicycle is properly fitted to the child; that it is in good repair and safe operating condition; that you and your child have learned and understand the safe operation of the bicycle; and that you and your child have learned, understand and obey not only the applicable local motor vehicle, bicycle and traffic laws, but also the common sense rules of safe and responsible bicycling. As a parent, you should read this manual, as well as review its warnings and the bicycle's functions and operating procedures with your child, before letting your child ride the bicycle.

 **WARNING**

Make sure that your child always wears an approved bicycle helmet when riding; but also make sure that your child understands that a bicycle helmet is for bicycling only, and must be removed when not riding. A helmet must not be worn while playing, in play areas, on playground equipment, while climbing trees, or at any time while not riding a bicycle. Failure to follow this warning could result in serious injury or death.

This page has been left blank intentionally.

1 FIRST

NOTE: We strongly urge you to read this Manual in its entirety before your first ride. At the very least, read and make sure that you understand each point in this section, and refer to the cited sections on any issue which you don't completely understand. Please note that not all bicycles have all of the features described in this Manual. In case of questions, contact Darkside customer service to point out the features of your bicycle.

1.1 BIKE FIT

1. Is your bike the right size? To check, see Section 3.1. If your bicycle is too large or too small for you, you may lose control and fall. If your new bike is not the right size, contact Darkside customer service to exchange it before you ride it.
2. Is the saddle at the right height? To check, see Section 3.2. If you adjust your saddle height, follow the Minimum Insertion instructions in Section 3.2.
3. Are saddle and seat post securely clamped? A correctly tightened saddle will allow no saddle movement in any direction. See Section 3.2.
4. Are the stem and handlebars at the right height for you? If not, see Section 3.3.
5. Can you comfortably operate the brakes? If not, you may be able to adjust their angle and reach. See Section 3.4 and 3.5.
6. Do you fully understand how to operate your new bicycle? If not, before your first ride, contact Darkside customer service to explain any functions or features which you do not understand.

1.2 SAFETY FIRST

1. Always wear an approved helmet when riding your bike, and follow the helmet manufacturer's instructions for fit, use and care.

2. Do you have all the other required and recommended safety equipment? See Section 2. It's your responsibility to familiarize yourself with the laws of the areas where you ride, and to comply with all applicable laws.
3. Do you know how to correctly secure your front and rear wheels? Check Section 4.1 to make sure. Riding with an improperly secured wheel can cause the wheel to wobble or disengage from the bicycle, and cause serious injury or death.
4. If your bike has toe clips and straps or clipless ("step-in") pedals, make sure you know how they work (see Section 4.3). These pedals require special techniques and skills. Follow the pedal manufacturer's instructions for use, adjustment and care.
5. Do you have "toe overlap"? On smaller framed bicycles your shoe or toe clip may be able to contact the front wheel when a pedal is all the way forward and the wheel is turned. Read Section 4.3 to check whether you have toe clip overlap.

1.3 MECHANICAL SAFETY CHECK

Routinely check the condition of your bicycle before every ride. If the bicycle or any part thereof does not pass inspection, ensure this is fixed before riding. Consult your Darkside customer service if you have any questions.

- **Nuts, bolts screws & other fasteners:** Because manufacturers use a wide variety of fastener sizes and shapes made in a variety of materials, often differing by model and component, the correct tightening force or torque cannot be generalized. To make sure that the many fasteners on your bicycle are correctly tightened, refer to the Fastener-Torque Specifications in Appendix C of this manual or to the torque specifications in the instructions provided by the manufacturer of the component in question. Correctly tightening a fastener requires a calibrated torque wrench. A professional bicycle mechanic with a torque wrench should torque the fasteners on your bicycle. If you choose to work on your own bicycle, you must use a torque wrench and the correct tightening torque specifications from the bicycle or component manufacturer. If you need to make an adjustment at home or in the field, we urge you to exercise care, and to have the fasteners you worked on checked by a professional bicycle mechanic as soon as possible.

Note: there are some components that require special tools and knowledge. In Sections 4 and 7 we discuss the items that you may be able to adjust yourself. All other adjustments and repairs should be done by a qualified bicycle mechanic.

WARNING

Correct tightening force on fasteners – nuts, bolts, screws – on your bicycle is important. Too little force, and the fastener may not hold securely. Too much force, and the fastener can strip threads, stretch, deform or break. Either way, incorrect tightening force can result in component failure, which can cause you to lose control and fall.

- **Check visually for any damage on your bicycle.** If anything looks incorrect or suspicious please contact Darkside customer service.
- **Make sure nothing is loose.** Lift the front wheel off the ground by two or three inches, then let it bounce on the ground. Anything sound, feel or look loose? Do a visual and tactile inspection of the whole bike. Any loose parts or accessories? If so, secure them. If you're not sure, ask someone with experience to check.
- **Tires & Wheels:** Make sure tires are correctly inflated (see Section 4.1). Check by putting one hand on the saddle, one on the intersection of the handlebars and stem, then bouncing your weight on the bike while looking at tire deflection. Compare what you see with how it looks when you know the tires are correctly inflated; and adjust if necessary.
- **Tires in good shape?** Spin each wheel slowly and look for cuts in the tread and sidewall. Replace damaged tires before riding the bike.
- **Wheels true?** Spin each wheel and check for brake clearance and side-to-side wobble. If a wheel wobbles side to side even slightly, or rubs against or hits the brake pads, take the bike to a qualified bike shop to have the wheel trued.

CAUTION

Wheels must be true for rim brakes to work effectively. Wheel truing is a skill which requires special tools and experience. Do not attempt to true a wheel unless you have the knowledge, experience and tools needed to do the job correctly.

- **Wheel rims clean and undamaged?** Make sure the rims are clean and undamaged at the tire bead and, if you have rim brakes, along the braking surface. Check to make sure that any rim wear indicator marking is not visible at any point on the wheel rim.

WARNING

Bicycle wheel rims are subject to wear. Ask your local bicycle dealer or Darkside customer service about wheel rim wear. Some wheel rims have a rim wear indicator which becomes visible as the rim's braking surface wears. A visible rim wear indicator on the side of the wheel rim is an indication that the wheel rim has reached its maximum usable life. Riding a wheel that is at the end of its usable life can result in wheel failure, which can cause you to lose control and fall.

- **Brakes:** Check brakes for proper operation (see Sections 4.2). Squeeze the brake levers.
 - Are the brake quick-releases closed? All control cables seated and securely engaged?
 - If you have rim brakes, do the brake pads contact the wheel rim squarely, making full contact with the rim?
 - Do the brakes begin to engage within an inch of brake lever movement?
Can you apply full braking force at the levers without having them touch the handlebar?
 - If not, your brakes need adjustment. Do not ride the bike until the brakes are properly adjusted by a professional bicycle mechanic.

FIRST

- **Wheel retention system:** Make sure the front and rear wheels are correctly secured. See Section 4.1.
- **Handlebar and saddle alignment:** Make sure the saddle and handlebar stem are parallel to the bike's center line and clamped tight enough so that you can't twist them out of alignment, or move them up or down. Ensure no cables interfere or bind when the handlebar is rotated side to side. See Sections 3.2 and 3.3
- **Handlebar ends:** Make sure the handlebar grips are secure and in good condition, with no cuts, tears, or worn out areas. If not, replace them. Make sure the handlebar ends and extensions are plugged. If the handlebars have bar end extensions, make sure they are clamped tight enough so you can't twist them.



WARNING

Loose or damaged handlebar grips or extensions can cause you to lose control and fall. Unplugged handlebars or extensions can cut you and cause serious injury in an otherwise minor accident.

- **Chain:** Check that the chain is not kinked or rusted, and does not have broken plates, pins, or rollers. Ensure the tension is correct so that it does not fall off when the pedals are rotated.
- **Pedals:** Check that the pedals are tightened onto the crankarm. Ensure the pedals and shoes are clean and that debris will not interfere with the pedal system

VERY IMPORTANT SAFETY NOTE: Please also read and become thoroughly familiar with the important information on the lifespan of your bicycle and its components in Appendix B on page 38).

1.4 FIRST RIDE

When you buckle on your helmet and go for your first familiarization ride on your new bicycle, be sure to pick a controlled environment, away from cars, other cyclists, obstacles or other hazards. Ride to become familiar with the controls, features and performance of your new bike.

Familiarize yourself with the braking action of the bike (see Section 4.2). Test the brakes at slow speed, putting your weight toward the rear and gently applying the brakes, rear brake first. Sudden or excessive application of the front brake could pitch you over the handlebars. Applying brakes too hard can lock up a wheel, which could cause you to lose control and fall. Skidding is an example of what can happen when a wheel locks up.

If your bicycle has toe clips or clipless pedals, practice getting in and out of the pedals. See Section 1.2 paragraph 4. above and Section 4.3 paragraph 4.

Check out the handling and response of the bike; and check the comfort.

If you have any questions, or if you feel anything about the bike is not as it should be, contact Darkside customer service before you ride again.

2 SAFETY

2.1 THE BASICS

WARNING

The area in which you ride may require specific safety devices. It is your responsibility to familiarize yourself with the laws of the area where you ride and to comply with all applicable laws, including properly equipping yourself and your bike as the law requires. Observe all local bicycle laws and regulations. Observe regulations about bicycle lighting, licensing of bicycles, riding on sidewalks, laws regulating bike path and trail use, helmet laws, child carrier laws, special bicycle traffic laws. It's your responsibility to know and obey the laws.

Observe all local bicycle laws and regulations. Observe regulations about bicycle lighting, licensing of bicycles, riding on sidewalks, laws regulating bike path and trail use, helmet laws, child carrier laws, special bicycle traffic laws. It's your responsibility to know and obey the laws

- Always wear a cycling helmet which meets the latest certification standards and is appropriate for the type of riding you do (fig. 1). Always follow the helmet manufacturer's instructions for fit, use and care of your helmet. Most serious bicycle injuries involve head injuries which might have been avoided if the rider had worn an appropriate helmet.

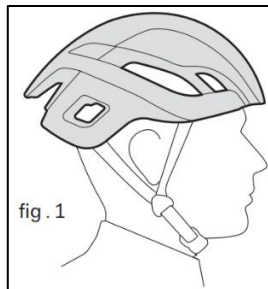

WARNING

Failure to wear a helmet when riding may result in serious injury or death.

Always do the Mechanical Safety Check (Section 1.3) before you get on a bike.

Be thoroughly familiar with the controls of your bicycle: brakes (Section 4.2); pedals (Section 4.3).

Be careful to keep body parts and other objects away from the sharp teeth of chain rings, the moving chain, the turning pedals and cranks, and the spinning wheels of your bicycle.

Always wear:

- Shoes that will stay on your feet and will grip the pedals. Make sure that shoe laces cannot get into moving parts, and never ride barefoot or in sandals.
- Bright, visible clothing that is not so loose that it can be tangled in the bicycle or snagged by objects at the side of the road or trail.
- Protective eyewear, to protect against airborne dirt, dust and bugs — tinted when the sun is bright, clear when it's not.

Don't jump with your bike. Jumping a bike can be fun; but it can put huge and unpredictable stress on the bicycle and its components. Riders who insist on jumping their bikes risk serious damage, to their bicycles as well as to themselves. Before you attempt to jump, do stunt riding or race with your bike, read and understand Section 2.6. and 2.7.

Ride at a speed appropriate for conditions. Higher speed means higher risk.

2.2 RIDING SAFETY

- Obey all Rules of the Road and all local traffic laws.

You are sharing the road or the path with others — motorists, pedestrians and other cyclists. Respect their rights.

Ride defensively. Always assume that others do not see you.

Look ahead, and be ready to avoid:

- Vehicles slowing or turning, entering the road or your lane ahead of you, or coming up behind you.
- Parked car doors opening.

SAFETY

- Pedestrians stepping out.
- Children or pets playing near the road.
- Pot holes, sewer grating, railroad tracks, expansion joints, road or sidewalk construction, debris and other obstructions that could cause you to swerve into traffic, catch your wheel or cause you to have an accident.
- The many other hazards and distractions which can occur on a bicycle ride.

Ride in designated bike lanes, on designated bike paths or as close to the edge of the road as possible, in the direction of traffic flow or as directed by local governing laws.

Stop at stop signs and traffic lights; slow down and look both ways at street intersections. Remember that a bicycle always loses in a collision with a motor vehicle, so be prepared to yield even if you have the right of way.

Use approved hand signals for turning and stopping.

Never ride with headphones. They mask traffic sounds and emergency vehicle sirens, distract you from concentrating on what's going on around you, and their wires can tangle in the moving parts of the bicycle, causing you to lose control.

Never carry a passenger. Refer to Appendix A.

Never carry anything which obstructs your vision or your complete control of the bicycle, or which could become entangled in the moving parts of the bicycle.

Never hitch a ride by holding on to another vehicle.

Don't do stunts, wheelies or jumps. If you intend to do stunts, wheelies, jumps or go racing with your bike despite our advice not to, read Section 2.6. and 2.7., Extreme, Stunt, or Competition riding, now. Think carefully about your skills before deciding to take the large risks that go with this kind of riding.

Don't weave through traffic or make any moves that may surprise people with whom you are sharing the road.

Observe and yield the right of way.

Never ride your bicycle while under the influence of alcohol or drugs.

If possible, avoid riding in bad weather, when visibility is obscured, at dawn, dusk or in the dark, or when extremely tired. Each of these conditions increases the risk of accident.

Always take along some kind of identification, so that people know who you are in case of an accident; and take along a couple of dollars in cash for a candy bar, a cool drink or an emergency phone call.

2.3 OFF ROAD SAFETY

We recommend that children not ride on rough terrain unless they are accompanied by an adult.

- The variable conditions and hazards of off-road riding require close attention and specific skills. Start slowly on easier terrain and build up your skills. Get to know how to handle your bike safely before trying increased speed or more difficult terrain.

Wear safety gear appropriate to the kind of riding you plan to do.

Don't ride alone in remote areas. Even when riding with others, make sure that someone knows where you're going and when you expect to be back.

Always take along some kind of identification, so that people know who you are in case of an accident; and take along some cash for food, a cool drink or an emergency phone call.

Yield right of way to pedestrians and animals. Ride in a way that does not frighten or endanger them, and give them enough room so that their unexpected moves don't endanger you.

Be prepared. If something goes wrong, help may not be close.

Before you attempt to jump, do stunt riding or race with your bike, read and understand Section 2.6. and 2.7..

Off Road Respect

Obey the local laws regulating where and how you can ride off-road, and respect private property. You may be sharing the trail with others — hikers, equestrians, other cyclists. Respect their rights. Stay on the designated trail. Don't contribute to erosion by riding in mud or with unnecessary sliding. Don't disturb the ecosystem by cutting your own trail or shortcut through vegetation or streams. It is your responsibility to minimize your impact on the

environment. Leave things as you found them; and always take out everything you brought in.

2.4 WET WEATHER RIDING

WARNING

Wet weather impairs traction, braking and visibility, both for the bicyclist and for other vehicles sharing the road. The risk of an accident is dramatically increased in wet conditions.

Under wet conditions, the stopping power of your brakes (as well as the brakes of other vehicles sharing the road) is dramatically reduced and your tires don't grip nearly as well. This makes it harder to control speed and easier to lose control. To make sure that you can slow down and stop safely in wet conditions, ride more slowly and apply your brakes earlier and more gradually than you would under normal, dry conditions. See also Section 4.2.

2.5 NIGHT RIDING

Riding a bicycle at night is much more dangerous than riding during the day. A bicyclist is very difficult for motorists and pedestrians to see. Therefore, children should never ride at dawn, at dusk or at night. Adults who chose to accept the greatly increased risk of riding at dawn, at dusk or at night need to take extra care both riding and choosing specialized equipment which helps reduce that risk. Contact Darkside customer service about night riding safety equipment.

WARNING

Reflectors are not a substitute for required lights. Riding at dawn, at dusk, at night or at other times of poor visibility without an adequate bicycle lighting system and without reflectors is dangerous and may result in serious injury or death.

CAUTION

Check reflectors and their mounting brackets regularly to make sure that they are clean, straight, unbroken and securely mounted. Have your local bicycle dealer replace damaged reflectors and straighten or tighten any that are bent or loose.

Bicycle reflectors are designed to pick up and reflect car lights and street lights in a way that may help you to be seen and recognized as a moving bicyclist.

WARNING

Do not remove the front or rear reflectors or reflector brackets from your bicycle. They are an integral part of the bicycle's safety system. Removing the reflectors reduces your visibility to others using the roadway. Being struck by other vehicles may result in serious injury or death.

If you choose to ride under conditions of poor visibility, check and be sure you comply with all local laws about night riding, and take the following strongly recommended additional precautions:

- Purchase and install battery or generator powered head and tail lights which meet all regulatory requirements and provide adequate visibility.
- Wear light coloured, reflective clothing and accessories, such as a reflective vest, reflective arm and leg bands, reflective stripes on your helmet, flashing lights attached to your body and/or your bicycle ... any reflective device or light source that moves will help you get the attention of approaching motorists, pedestrians and other traffic.
- Make sure your clothing or anything you may be carrying on the bicycle does not obstruct a reflector or light.
- Make sure that your bicycle is equipped with correctly positioned and securely mounted reflectors.

While riding at dawn, at dusk or at night:

- Ride slowly.

- Avoid dark areas and areas of heavy or fast-moving traffic.
- Avoid road hazards.
- If possible, ride on familiar routes.

If riding in traffic:

- Be predictable. Ensure drivers can see you and predict your movements.
- Be alert. Ride defensively and expect the unexpected.
- If you plan to ride in traffic often, ask Darkside customer service about traffic safety classes or a good book on bicycle traffic safety.

WARNING

Although many catalogues, advertisements and articles about bicycling depict riders engaged in racing or competition, this activity can be extremely dangerous, increases your risk of injury, severity of an injury, or even death. Remember that the action depicted is being performed by professionals with many years of training and experience. Know your limits and always wear a helmet and other appropriate safety gear. Even with state-of-the-art protective safety gear, you could be seriously injured or killed when riding at speed or in competition.

WARNING

Bicycles and bicycle parts have limitations with regard to strength and integrity, and riding in competition can exceed those limitations. In particular the following situations can exceed the design limits of your bicycle, and result in a loss of control and falling which could result in serious injury or death: Hopping/jumping your bicycle. Riding over curbs, sticks or debris. Impacts or crashes (see Section 5.2). Other situations the bicycle was not designed for (see Appendix A).

2.6 RACING OR COMPETITION

- Hopping/jumping your bicycle
- Riding over curbs, sticks or debris
- Impacts or crashes (See Section 5.2)
- Other situations the bicycle was not designed for (See Appendix A)

Darkside bicycles are designed for road riding. However, without proper maintenance and regular inspection (refer to Section 5.1), or with substitution of inappropriate components (Section 2.8), the safety and reliability of your bicycle can be compromised. When riding fast in competition or downhill, you can reach speeds achieved by motorcycles, and therefore face similar hazards and risks. Have your bicycle and equipment carefully inspected by a qualified mechanic and be sure it is in perfect condition. Consult with expert riders, area site personnel and race officials on conditions and equipment advisable at the site where you plan to ride. Wear appropriate safety gear. Ultimately, it is your responsibility to have proper equipment and to be familiar with course conditions.

We also recommend the following before competing with your Darkside Bicycle:

- Start with easy learning exercises and slowly develop your skills
- Use only designated or appropriate areas for racing or fast downhill riding
- Always wear a helmet and other appropriate safety gear
- Understand and recognize that the stresses imposed on your bike by this kind of activity may break or damage parts of the bicycle and void the warranty
- Take your bicycle to a professional bicycle mechanic or contact Darkside customer service if anything breaks or bends. Do not ride your bicycle when any part is damaged.

If you ride downhill at speed, or ride in competition, know the limits of your skill and experience. Ultimately, avoiding injury is your responsibility.

2.7 EXTREM OR STUNT RIDING

Whether you call it Aggro, Hucking, Freeride, North Shore, Downhill, Jumping, Stunt Riding, or something else: if you engage in this sort of extreme, aggressive riding you will get hurt, and you voluntarily assume a greatly increased risk of injury or death.

WARNING

Darkside bicycles are not designed for these types of riding under any circumstances. Refer to Appendix A for intended use of your bicycle. Engaging in any of these activities will increase your risk of injury or death, increases the severity of any injury, and will also void your warranty.

2.8 CHANGING COMPONENTS OR ADDING ACCESSORIES

There are many components and accessories available to enhance the comfort, performance and appearance of your bicycle. However, if you change components or add accessories, you do so at your own risk. Darkside may not have tested that component or accessory for compatibility, reliability or safety on your bicycle. Before installing any component or accessory, including a different size tire, make sure that it is compatible with your bicycle by checking with your local bicycle dealer or with Darkside customer Service. Be sure to read, understand and follow the instructions that accompany the products you purchase for your bicycle. See also Appendix A and B.

WARNING

Changing the components on your bike with other than genuine replacement parts may compromise the safety of your bicycle and may void the warranty. Check with your local bicycle dealer or Darkside customer service before changing the components on your bike. Failure to confirm compatibility, properly install, operate and maintain any component or accessory can result in serious injury or

2.9 AEROBAR

CAUTION

Care should be exercised when utilizing aerobars at all times, as these bars, while highly effective at decreasing aerodynamic drag, also decrease the bicycle's ability to steer and brake relative to standard handlebars.

Braking is made more difficult when using aerobars as your hands are positioned further from the brake levers compared to standard handlebars – in an emergency you need first sit up and move your hands back towards the base bar and out to the brake levers to begin braking. If brake levers are attached to the aerobars, you must remember that your weight is positioned further forward than normal, with more weight on the front wheel. Caution should be exercised when braking from this position as the forward weight bias makes it more likely for you to flip over the front wheel if the front brake is applied too strongly. See also Section 4.2. Regarding handling, the bike is more difficult to steer from the aero hand position as you are steering with your elbows instead of hands, and with a narrower total width as compared to standard handlebars. This makes it more difficult to ride in a straight line, and the bike will react more strongly to bumps or other unexpected inputs. It is highly recommended that you initially practice riding in a smooth, flat area, away from traffic, until you become familiar with the handling characteristics imparted by aerobars. Once mastered, aerobars are never recommended for use when riding in a group or in heavy traffic for safety reasons.

WARNING

Failure to confirm compatibility, properly install, operate and maintain any aerobar or related component or accessory can result in serious injury or death.

3 FIT

NOTE: Correct fit is an essential element of bicycling safety, performance and comfort. Making the adjustments to your bicycle which result in correct fit for your body and riding conditions requires experience, skill and special tools. Always have a professional bicycle mechanic make the adjustments on your bicycle; or, if you have the experience, skill and tools, have a professional bicycle mechanic check your work before riding.

WARNING

If your bicycle does not fit properly, you may lose control and fall. If your new bike doesn't fit, contact Darkside customer service to exchange it before you ride it.

3.1 STANDOVER HEIGHT

1. Diamond Frame Bicycles

Standover height is the basic element of bike fit (see fig. 2). It is the distance from the ground to the top of the bicycle's frame at that point where your crotch is when straddling the bike. To check for correct standover height, straddle the bike while wearing the kind of shoes in which you'll be riding, and bounce vigorously on your heels. If your crotch touches the frame, the bike is too big for you. Don't even ride the bike around the block. A bike which you ride only on paved surfaces and never take off-road should give you a minimum standover height clearance of 5 cm (2 inches). A bike that you'll ride on unpaved surfaces should give you a minimum of 7,5 cm (3 inches) of standover height clearance. And a bike that you'll use off road should give you 10 cm (4 inches) or more of clearance.

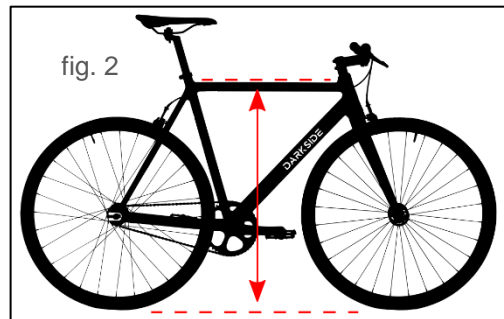

2. Step-Through Frame Bicycles

Standover height does not apply to bicycles with step-through frames. Instead, the limiting dimension is determined by saddle height range. You must be able to adjust your saddle position as described in 3.2 without exceeding the limits set by the height of the top of the seat tube and the "Minimum Insertion" or "Maximum Extension" mark on the seat post.

3.2 SADDLE POSITION

Correct saddle adjustment is an important factor in getting the most performance and comfort from your bicycle. If the saddle position is not comfortable for you, see your local bicycle shop.

The saddle can be adjusted in three directions:

1. Up and Down Adjustment

For correct saddle height (fig. 3):

- Sit on the saddle;
- Place one heel on a pedal;
- Rotate crank until the pedal with your heel on it is in the down position and the crank arm is parallel to the seat tube.

If your leg is not completely straight, your saddle height needs to be adjusted. If your hips must rock for the heel to reach the pedal, the saddle is too high. If your leg is bent at the knee with your heel on the pedal, the saddle is too low.

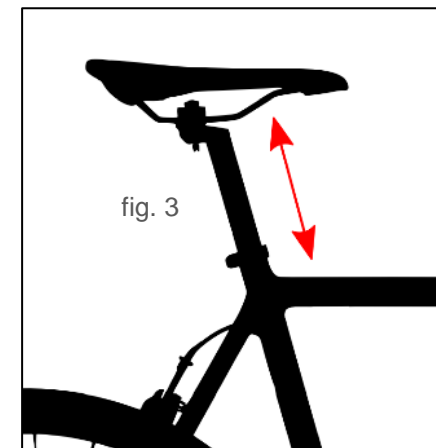

Ask your local bicycle dealer to set the saddle for your optimal riding position and to show you how to make this adjustment. If you choose to make your own saddle height adjustment:

- Loosen the seat post clamp.
- Raise or lower the seat post in the seat tube.
- Make sure the saddle is straight fore and aft.
- Re-tighten the seat post clamp to the recommended torque (Appendix C or the manufacturer's instructions).
- Once the saddle is at the correct height, make sure that the seat post does not project from the frame beyond its "Minimum Insertion" or "Maximum Extension" mark (fig. 4).

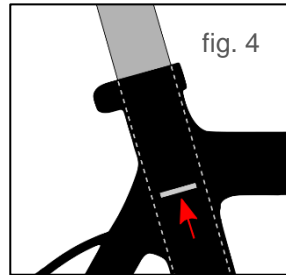

NOTE: Some bicycles have a sight hole in the seat tube, which make it easy to see whether the seat post is inserted in the seat tube far enough to be safe. If your bicycle has such a sight hole, use it instead of the "Minimum Insertion" or "Maximum Extension" mark to make sure the seat post is inserted in the seat tube far enough to be visible through the sight hole.

WARNING

If your seat post is not inserted in the seat tube as described in section 3.2 paragraph 1., the seat post may break, which could cause you to lose control and fall.

2. Front & Back Adjustment

The saddle can be adjusted forward or back to help you get the optimal position on the bike. Ask your local bicycle dealer to set the saddle mal riding position and to show you how to make this adjustment. If you choose to make your own front and back adjustment, make sure that the clamp mechanism is clamping on the straight part of the saddle rails and is not touching the curved part of the rails, and that you are using the recommended torque on the clamping fastener(s) (Appendix C or the manufacturer's instructions).

3. Saddle Angle Adjustment

Most people prefer a horizontal saddle; but some riders like the saddle nose angled up or down just a little. Your local bicycle dealer can adjust saddle angle or teach you how to do it. If you choose to make your own saddle angle adjustment and you have a single bolt saddle clamp on your seat post, it is critical that you loosen the clamp bolt sufficiently to allow any serrations on the mechanism to disengage before changing the saddle's angle, and then that the serrations fully re-engage before you tighten the clamp bolt to the recommended torque (Appendix C or the manufacturer's instructions).

WARNING

When making saddle angle adjustments with a single bolt saddle clamp, always check to make sure that the serrations on the mating surfaces of the clamp are not worn. Worn serrations on the clamp can allow the saddle to move, causing you to lose control and fall. Always tighten fasteners to the correct torque. Bolts that are too tight can stretch and deform. Bolts that are too loose can move and fatigue. Either mistake can lead to a sudden failure of the bolt, causing you to lose control and fall.

Small changes in saddle position can have a substantial effect on performance and comfort. To find your best saddle position, make only one adjustment at a time.

WARNING

After any saddle adjustment, be sure that the saddle adjusting mechanism is properly seated and tightened before riding. A loose saddle clamp or seat post clamp can cause damage to the seat post, or can cause you to lose control and fall. A correctly tightened saddle adjusting mechanism will allow no saddle movement in any direction. Periodically check to make sure that the saddle adjusting mechanism is properly tightened.

If, in spite of carefully adjusting the saddle height, tilt and fore-and-aft position, your saddle is still uncomfortable, you may need a different saddle design.

Saddles, like people, come in many different shapes, sizes and resilience. Your local bicycle shop can help you select a saddle which, when correctly adjusted for your body and riding style, will be comfortable.

⚠ WARNING

Some people have claimed that extended riding with a saddle which is incorrectly adjusted or which does not support your pelvic area correctly can cause short-term or long-term injury to nerves and blood vessels, or even impotence. If your saddle causes you pain, numbness or other discomfort, listen to your body and stop riding until you visit your local bicycle shop about saddle adjustment or a different saddle.

3.3 HANDLEBAR HEIGHT & ANGLE

Your bike is equipped either with a “threadless” stem, which clamps on to the outside of the steerer tube, or with a “quill” stem, which clamps inside the steerer tube by way of an expanding binder bolt. If you aren’t absolutely sure which type of stem your bike has, ask Darkside customer service. **Darkside bicycles are delivered with threadless stems exclusively.**

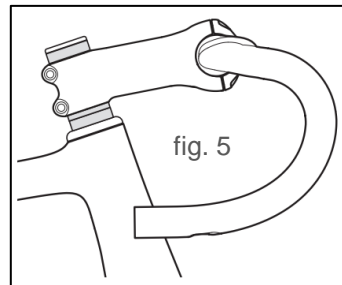

If your bike has a “threadless” stem (fig. 5) your local bicycle dealer may be able to change handlebar height by moving height adjustment spacers from below the stem to above the stem, or vice versa. Otherwise, you’ll have to get a stem of different length or rise. Consult your local bicycle dealer or Darkside customer service. Do not attempt to do this yourself, as it requires special knowledge.

⚠ WARNING

Do not exceed the number of height adjustment spacers below the stem that were initially provided with the bicycle or recommended by Darkside Bicycles. Exceeding the maximum spacer height can result in damage to the fork’s steerer tube, which could cause you to lose control and fall.

⚠ WARNING

On some bicycles, changing the stem or stem height can affect the tension of the front brake cable, locking the front brake or creating excess cable slack which can make the front brake inoperable. If the front brake pads move in towards the wheel rim or out away from the wheel rim when the stem or stem height is changed, the brakes must be correctly adjusted before you ride the bicycle.

Some bicycles are equipped with an adjustable angle stem. If your bicycle has an adjustable angle stem, ask your local bicycle dealer to show you how to adjust it. Do not attempt to make the adjustment yourself, as changing stem angle may also require adjustments to the bicycle’s controls.

⚠ WARNING

Always tighten fasteners to the correct torque. Bolts that are too tight can stretch and deform. Bolts that are too loose can move and fatigue. Either mistake can lead to a sudden failure of the bolt, causing you to lose control and fall.

Your local bicycle dealer/ a professional bicycle mechanic can also change the angle of the handlebar or bar end extensions.

 **WARNING**

An insufficiently tightened stem clamp bolt, handlebar clamp bolt or bar end extension clamping bolt may compromise steering action, which could cause you to lose control and fall. Place the front wheel of the bicycle between your legs and attempt to twist the handlebar/stem assembly. If you can twist the stem in relation to the front wheel, turn the handlebars in relation to the stem, or turn the bar end extensions in relation to the handlebar, the bolts are insufficiently tightened.

3.4 CONTROL POSITION ADJUSTMENT

The angle of the brake and shift control levers and their position on the handlebars can be changed. Ask your local bicycle dealer / a professional bicycle mechanic to make the adjustments for you. If you choose to make your own control lever angle adjustment, be sure to re-tighten the clamp fasteners to the recommended torque (Appendix C or the manufacturer's instructions).

3.5 BRAKE REACH

Many bikes have brake levers which can be adjusted for reach. If you have small hands or find it difficult to squeeze the brake levers, your local bicycle dealer / a professional bicycle mechanic can either adjust the reach or fit shorter reach brake levers.

 **WARNING**

The shorter the brake lever reach, the more critical it is to have correctly adjusted brakes, so that full braking power can be applied within available brake lever travel. Brake lever travel insufficient to apply full braking power can result in loss of control, which may result in serious injury or death.

This page has been left blank intentionally.

4 TECHNOLOGY

It's important to your safety, performance and enjoyment to understand how things work on your bicycle. We urge you to ask your local bicycle dealer or Darkside customer service how to do the things described in this section before you attempt them yourself, and that you have your local bicycle dealer / professional bicycle mechanic check your work before you ride the bike. If you have even the slightest doubt as to whether you understand something in this section of the Manual, talk to a professional bicycle mechanic or contact our service hotline. See also Appendix A, B, & C.

Darkside bicycles are shipped from the warehouse to the customer only partially assembled. It is strongly recommended to perform the assembly and fitting operations by a professional bicycle mechanic, as it requires specific knowledge of each part, appropriate tools, and understanding of the interactions of various materials. Your bicycle is a high-performance machine, and as such requires skilled maintenance in order to function safely and effectively.

4.1 WHEELS

Bicycle wheels are designed to be removable for easier transportation and for repair of a tire puncture. In most cases, the wheel axles are inserted into slots, called "dropouts" in the fork and frame, but some mountain and road bikes use what is called a "through axle" wheel mounting system.

If you have a mountain or road bike equipped with through axle front or rear wheels, make sure that your dealer has given you the manufacturer's instructions, and follow those when installing or removing a through axle wheel. If you don't know what a through axle is, contact customer service.

If you do not have a bicycle with a through-axle wheel mounting system, it will have wheels secured in one of three ways:

- A hollow axle with a shaft skewer running through it which has an adjustable tension nut on one end and an over-center cam on the other (cam action system or Quick Release System, Fig. 7a & 7b).

- A hollow axle with a shaft skewer running through it which has a nut on one end and a fitting for a hex key, lock lever or other tightening device on the other (through bolt, fig. 8).
- Hex nuts or hex key bolts which are threaded on to or into the hub axle (bolt-on wheel, fig. 9).

Darkside bicycles front and rear wheels are equipped with bolt-on wheel exclusively, see fig.9.

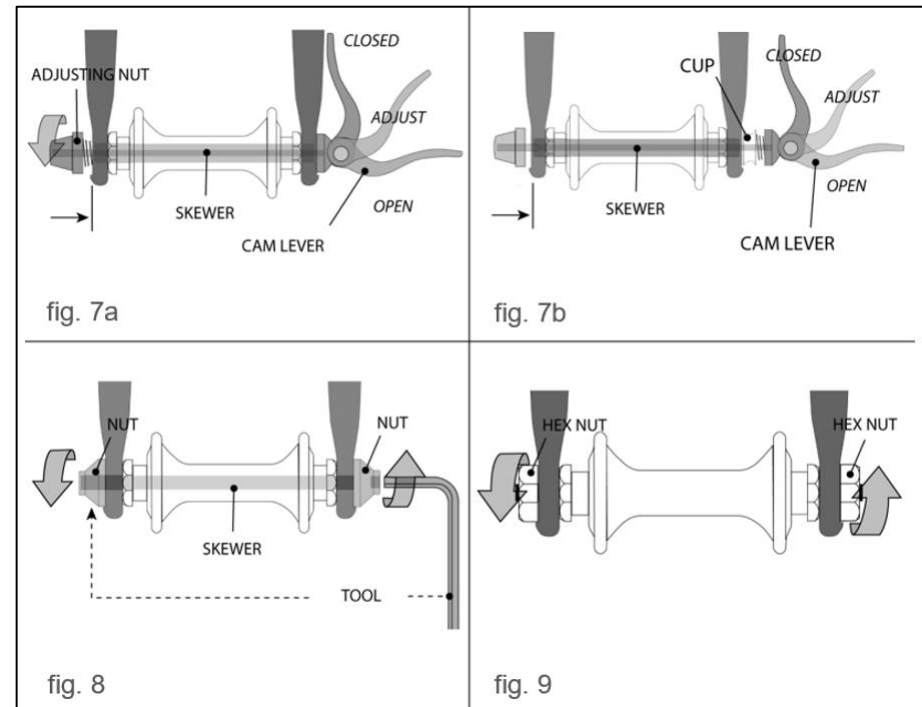

Your bicycle may be equipped with a different securing method for the front wheel than for the rear wheel. Discuss the wheel securing method for your bicycle with your retailer.

It is very important that you understand the type of wheel securing method on your bicycle, that you know how to secure the wheels correctly, and that you know how to apply the correct clamping force

that safely secures the wheel. Ask a professional bicycle mechanic or Darkside customer service to instruct you in correct wheel removal and installation, and ask for any available manufacturer's instructions.

 **WARNING**

Riding with an improperly secured wheel can allow the wheel to wobble or fall off the bicycle, which can cause serious injury or death.

Therefore, it is essential that you:

1. Understand and apply the correct technique for clamping your wheel in place.
2. Each time, before you ride the bike, check that the wheel is securely clamped.
3. The clamping action of a correctly secured wheel must emboss the surfaces of the dropouts.

1. Front Wheel Secondary Retention Devices

Most bicycles have front forks that utilize a secondary wheel retention device to reduce the risk of the wheel disengaging from the fork if the wheel is incorrectly secured. Secondary retention devices are not a substitute for correctly securing your front wheel.

Secondary retention devices fall into two basic categories:

- a. The clip-on type is a part that the manufacturer adds to the front wheel hub or front fork.
- b. The integral type is molded, cast or machined into the outer faces of the front fork dropouts. Contact customer service to explain the particular secondary retention device on your bike.

 **WARNING**

Do not remove or disable the secondary retention device. As its name implies, it serves as a back-up for a critical adjustment. If the wheel is not secured correctly, the secondary retention device can reduce the risk of the wheel disengaging from the fork. Removing or disabling the secondary retention device may also void the warranty. Secondary retention devices are not a substitute for correctly securing your wheel. Failure to properly secure the wheel can cause the wheel to wobble or disengage, which could cause you to lose control and fall, resulting in serious injury or death.

2. Wheels with Cam Action Systems (Quick Release)

There are currently two types of over-center cam wheel retention mechanisms: the traditional over-center cam (fig. 7) and the cam-and-cup system. Both use an over-center cam action to clamp the bike's wheel in place. Your bicycle may have a cam-and-cup front wheel retention system and a traditional rear wheel cam action system.

a. Adjusting the traditional cam action mechanism (fig. 7)

The wheel hub is clamped in place by the force of the over-center cam pushing against one dropout and pulling the tension adjusting nut, by way of the skewer, against the other dropout. The amount of clamping force is controlled by the tension adjusting nut. Turning the tension adjusting nut clockwise while keeping the cam lever from rotating increases clamping force; turning it counterclockwise while keeping the cam lever from rotating reduces clamping force. Less than half a turn of the tension adjusting nut can make the difference between safe clamping force and unsafe clamping force.

⚠ WARNING

The full force of the cam action is needed to clamp the wheel securely. Holding the nut with one hand and turning the lever like a wing nut with the other hand until everything is as tight as you can get it will not clamp a cam action wheel safely in the dropouts. See also the first WARNING in this Section.

b. Adjusting the cam-and-cup mechanism

The cam-and-cup system on your front wheel will have been correctly adjusted for your bicycle by your dealer. Ask your dealer / professional bicycle mechanic to check the adjustment every six months. Do not use a cam-and-cup front wheel on any bicycle other than the one for which your dealer adjusted it.

3. Removing and Installing wheels

⚠ WARNING

If your bike is equipped with a hub brake such as a rear coaster brake, front or rear drum, band or roller brake; or if it has an internal gear rear hub, do not attempt to remove the wheel. The removal and re-installation of most hub brakes and internal gear hubs requires special knowledge. Incorrect removal or assembly can result in brake or gear failure, which can cause you to lose control and fall.

⚠ CAUTION

If your bike has a disc brake, exercise care in touching the rotor or caliper. Disc rotors have sharp edges, and both rotor and caliper can get very hot during use.

a. Removing a disc brake or rim brake Front Wheel

- (1) If your bike has rim brakes, disengage the brake's quick-release mechanism to increase the clearance between the tire and the brake pads (see Section 4.2 fig. 11 through 14).
- (2) If your bike has cam action front wheel retention, move the cam lever from the locked or CLOSED position to the OPEN position (fig. 7). Then go to step (4).
- (3) If your bike has through bolt or bolt-on front (fig. 8, fig. 9) wheel retention, loosen the fastener(s) a few turns counter-clockwise using an appropriate wrench, lock key or the integral lever. Then go to step (4).
- (4) If your front fork has a clip-on type secondary retention device, disengage it. If your front fork has an integral secondary retention device, and a traditional cam action system (fig. 7) loosen the tension adjusting nut enough to allow removing the wheel from the dropouts. If your front wheel uses a cam-and-cup system, squeeze the cup and cam lever together while removing the wheel. No rotation of any part is necessary with the cam-and-cup system.
- (5) You may need to tap the top of the wheel with the palm of your hand to release the wheel from the front fork.

b. Installing a disc brake or rim brake Front Wheel

⚠ CAUTION

If your bike is equipped with a front disc brake, be careful not to damage the disc, caliper or brake pads when re-inserting the disc into the caliper. Never activate a disc brake's control lever unless the disc is correctly inserted in the caliper. See also Section 4.2.

- (1) If your bike has cam action front wheel retention, move the cam lever so that it curves away from the wheel (fig. 7). This is the OPEN position. If your bike has through bolt or bolt-on front wheel retention, go to the next step.
- (2) With the steering fork facing forward, insert the wheel between the fork blades so that the axle seats firmly at the top of the fork dropouts. The cam lever, if there is one, should be on rider's left side of the

TECHNOLOGY

bicycle (fig. 7). If your bike has a clip-on type secondary retention device, engage it.

- (3) If you have a traditional cam action mechanism: holding the cam lever in the ADJUST position with your right hand, tighten the tension adjusting nut with your left hand until it is finger tight against the fork dropout (fig. 7). If you have a cam-and-cup system: the nut and cup (fig. 7) will have snapped into the recessed area of the fork dropouts and no adjustment should be required.
- (4) While pushing the wheel firmly to the top of the slots in the fork dropouts, and at the same time centering the wheel rim in the fork.
 - (a) With a cam action system, move the cam lever upwards and swing it into the CLOSED position (fig. 7). The lever should now be parallel to the fork blade and curved toward the wheel. To apply enough clamping force, you should have to wrap your fingers around the fork blade for leverage, and the lever should leave a clear imprint in the palm of your hand.
 - (b) With a through-bolt or bolt-on system, tighten the fasteners to the torque specifications in Appendix C or the hub manufacturer's instructions.

NOTE: *If, on a traditional cam action system, the lever cannot be pushed all the way to a position parallel to the fork blade, return the lever to the OPEN position. Then turn the tension adjusting nut counterclockwise one-quarter turn and try tightening the lever again.*

WARNING

Securely clamping the wheel with a cam action retention device takes considerable force. If you can fully close the cam lever without wrapping your fingers around the fork blade for leverage, the lever does not leave a clear imprint in the palm of your hand, and the serrations on the wheel fastener do not emboss the surfaces of the dropouts, the tension is insufficient. Open the lever; turn the tension adjusting nut clockwise a quarter turn; then try again. See also the first WARNING in this Section.

- (5) If you disengaged the brake quick-release mechanism in 3. a. (1) above, re-engage it to restore correct brake pad-to-rim clearance.
- (6) Spin the wheel to make sure that it is centered in the frame and clears the brake pads; then squeeze the brake lever and make sure that the brakes are operating correctly.

c. Removing a disc brake or rim brake Rear Wheel

- (1) If you have a multi-speed bike with a derailleur gear system: shift the rear derailleur to high gear (the smallest, outermost rear sprocket). If you have an internal gear rear hub, consult your dealer or the hub manufacturer's instructions before attempting to remove the rear wheel. If you have a single-speed bike with rim or disc brake, go to step (4) below.
- (2) If your bike has rim brakes, disengage the brake's quick-release mechanism to increase the clearance between the wheel rim and the brake pads (see Section 4.2).
- (3) On a derailleur gear system, pull the derailleur body back with your right hand.
- (4) With a cam action mechanism, move the quickrelease lever to the OPEN position (fig. 7). With a through bolt or bolt on mechanism, loosen the fastener(s) with an appropriate wrench, lock lever or integral lever; then push the wheel forward far enough to be able to remove the chain from the rear sprocket.
- (5) Lift the rear wheel off the ground a few inches and remove it from the rear dropouts.

d. Installing a disc brake or rim brake Rear Wheel

CAUTION

If your bike is equipped with a rear disc brake, be careful not to damage the disc, caliper or brake pads when re-inserting the disc into the caliper. Never activate a disc brake's control lever unless the disc is correctly inserted in the caliper.

- (1) With a cam action system, move the cam lever to the OPEN position (see fig. 7). The lever should be on the side of the wheel opposite the derailleur and freewheel sprockets.
- (2) On a derailleur bike, make sure that the rear derailleur is still in its outermost, high gear, position; then pull the derailleur body back with your right hand. Put the chain on top of the smallest freewheel sprocket.
- (3) On single-speed, remove the chain from the front sprocket, so that you have plenty of slack in the chain. Put the chain on the rear wheel sprocket.
- (4) Then, insert the wheel into the frame dropouts and pull it all the way in to the dropouts.
- (5) On a single speed or an internal gear hub, replace the chain on the chainring; pull the wheel back in the dropouts so that it is straight in the frame and the chain has about 5 - 6 mm of up-and-down play.
- (6) With a cam action system, move the cam lever upwards and swing it into the CLOSED position (fig. 7). The lever should now be parallel to the seat stay or chain stay and curved toward the wheel. To apply enough clamping force, you should have to wrap your fingers around the fork blade for leverage, and the lever should leave a clear imprint in the palm of your hand.
- (7) With a through-bolt or bolt-on system, tighten the fasteners to the torque specifications in Appendix C or the hub manufacturer's instructions.

Note: *If, on a traditional cam action system, the lever cannot be pushed all the way to a position parallel to the seat stay or chain stay, return the lever to the OPEN position. Then turn the tension adjusting nut counterclockwise one-quarter turn and try tightening the lever again.*

 **WARNING**

Securely clamping the wheel with a cam action retention device takes considerable force. If you can fully close the cam lever without wrapping your fingers around the seat stay or chain stay for leverage, the lever does not leave a clear imprint in the palm of your hand, and the serrations on the wheel fastener do not emboss the surfaces of the dropouts, the tension is insufficient. Open the lever; turn the tension adjusting nut clockwise a quarter turn; then try again. See also the first WARNING in this Section.

- (8) If you disengaged the brake quick-release mechanism in 3. c. (2) above, re-engage it to restore correct brake pad-to-rim clearance.
- (9) Spin the wheel to make sure that it is centered in the frame and clears the brake pads; then squeeze the brake lever and make sure that the brakes are operating correctly.

4.2 BRAKES

There are three general types of bicycle brakes: rim brakes, which operate by squeezing the wheel rim between two brake pads; disc brakes, which operate by squeezing a hub-mounted disc between two brake pads; and internal hub brakes. All three can be operated by way of a handlebar mounted lever. On some models of bicycle, the internal hub brake is operated by pedaling backwards. This is called a Coaster Brake. **Darkside bicycles are equipped exclusively with Caliper-rim brakes.**

⚠ WARNING

- 1) Riding with improperly adjusted brakes, worn brake pads, or wheels on which the rim wear mark is visible is dangerous and can result in serious injury or death.
- 2) Applying brakes too hard or too suddenly can lock up a wheel, which could cause you to lose control and fall. Sudden or excessive application of the front brake may pitch the rider over the handlebars, which may result in serious injury or death.
- 3) Some bicycle brakes, such as disc brakes (fig. 10) and linear-pull brakes (fig. 11), are extremely powerful. Take extra care in becoming familiar with these brakes and exercise particular care when using them.
- 4) Some bicycle brakes are equipped with a brake force modulator, a small, cylindrical device through which the brake control cable runs and which is designed to provide a more progressive application of braking force. A modulator makes the initial brake lever force gentle, progressively increasing force until full force is achieved. If your bike is equipped with a brake force modulator, take extra care in becoming familiar with its performance characteristics.
- 5) Disc brakes can get extremely hot with extended use. Be careful not to touch a disc brake until it has had plenty of time to cool.

⚠ WARNING

- 5) Disc brakes can get extremely hot with extended use. Be careful not to touch a disc brake until it has had plenty of time to cool.
- 6) See the brake manufacturer's instructions for operation and care of your brakes, and for when brake pads must be replaced. If you do not have the manufacturer's instructions, contact Darkside customer service or contact the brake manufacturer.
- 7) If replacing worn or damaged parts, use only manufacturer-approved genuine replacement parts.

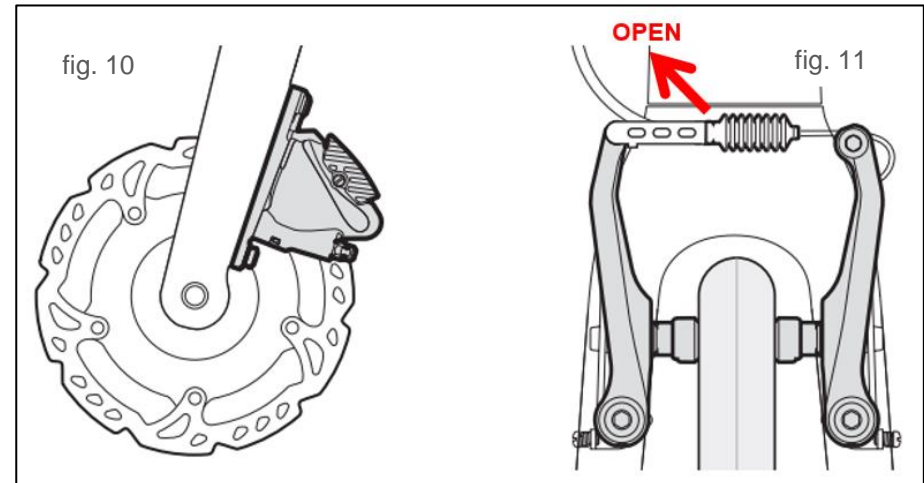

1. Brake Controls & Features

It's very important to your safety that you learn and remember which brake lever controls which brake on your bike. Traditionally, the right brake lever controls the rear brake and the left brake lever controls the front brake; but, to make sure your bike's brakes are set up this way, squeeze one brake lever and look to see which brake, front or rear, engages. Now do the same with the other brake lever.

Make sure that your hands can reach and squeeze the brake levers comfortably. If your hands are too small to operate the levers comfortably, consult your local bicycle dealer or Darkside customer service before riding the bike. The lever reach may be adjustable; or you may need a different brake lever design.

Most rim brakes have some form of quick-release mechanism to allow the brake pads to clear the tire when a wheel is removed or reinstalled. When the brake quick release is in the open position, the brakes are inoperative. Ask your local bicycle dealer or Darkside customer service to make sure that you understand the way the brake quick release works on your bike (see figs. 11, 12, 13 & 14) and check each time to make sure both brakes work correctly before you get on the bike.

2. How Brakes Work

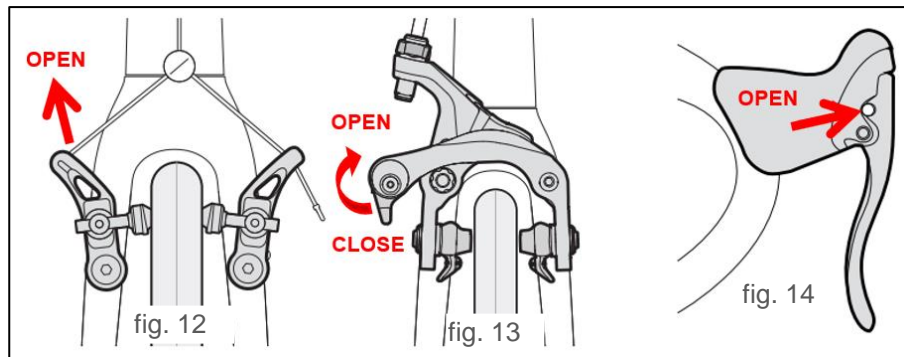

CAUTION

If your bike has a disc brake, take care to ensure that no oils or related products (hydraulic fluid, chain lube, finger oils) contact the brake pad materials. Contamination of brake pads by oil-based materials can significantly reduce the effectiveness of your braking system.

The braking action of a bicycle is a function of the friction between the braking surfaces. To make sure that you have maximum friction available, keep your

wheel rims and brake pads or the disc rotor and caliper clean and free of dirt, lubricants, waxes or polishes.

Brakes are designed to control your speed, not just to stop the bike. Maximum braking force for each wheel occurs at the point just before the wheel “locks up” (stops rotating) and starts to skid. Once the tire skids, you actually lose most of your stopping force and all directional control. You need to practice slowing and stopping smoothly without locking up a wheel. The technique is called progressive brake modulation. Instead of jerking the brake lever to the position where you think you’ll generate appropriate braking force, squeeze the lever, progressively increasing the braking force. If you feel the wheel begin to lock up, release pressure just a little to keep the wheel rotating just short of lockup. It’s important to develop a feel for the amount of brake lever pressure required for each wheel at different speeds and on different surfaces. To better understand this, experiment a little by walking your bike and applying different amounts of pressure to each brake lever, until the wheel locks.

When you apply one or both brakes, the bike begins to slow, but your body wants to continue at the speed at which it was going. This causes a transfer of weight to the front wheel (or, under heavy braking, around the front wheel hub, which could send you flying over the handlebars).

A wheel with more weight on it will accept greater brake pressure before lockup; a wheel with less weight will lock up with less brake pressure. So, as you apply brakes and your weight is transferred forward, you need to shift your body toward the rear of the bike, to transfer weight back on to the rear wheel; and at the same time, you need to both decrease rear braking and increase front braking force. This is even more important on descents, because descents shift weight forward.

Two keys to effective speed control and safe stopping are controlling wheel lockup and weight transfer. Practice braking and weight transfer techniques where there is no traffic or other hazards and distractions.

Everything changes when you ride on loose surfaces or in wet weather. It will take longer to stop on loose surfaces or in wet weather. Tire adhesion is reduced, so the wheels have less cornering and braking traction and can lock up with less brake force. Moisture or dirt on the brake pads reduces their ability to grip. The way to maintain control on loose or wet surfaces is to go more slowly.

4.3 PEDALS

1. Toe Overlap is when the toe of your shoe can touch the front wheel when turning the handlebars to steer while a pedal is in the forwardmost position. This is common on small-framed bicycles, and is avoided by keeping the inside pedal up and the outside pedal down when making sharp turns. On any bicycle, this technique will also prevent the inside pedal from striking the ground in a turn.

WARNING

Toe Overlap could cause you to lose control and fall. Ask Darkside customer service to help you determine if the combination of frame size, tire size, crank arm length, pedal design, and shoes you will use results in pedal overlap. Changing any of these combinations of parts could cause Toe Overlap to occur, even though it did not occur prior to a change. Whether you have overlap or not, you must keep the inside pedal up and the outside pedal down when making sharp turns.

2. Some bicycles come equipped with pedals that have sharp and potentially dangerous surfaces. These surfaces are designed to add safety by increasing grip between the rider's shoe and the pedal. If your bicycle has this type of high-performance pedal, you must take extra care to avoid serious injury from the pedals' sharp surfaces. Based on your riding style or skill level, you may prefer a less aggressive pedal design, or chose to ride with shin pads. Your local bicycle dealer can show you a number of options and make suitable recommendations.
3. Toe clips and straps are a means to keep feet correctly positioned and engaged with the pedals. The toe clip positions the ball of the foot over the pedal spindle, for maximum pedalling power. When tightened, toe straps keep the foot engaged through the pedal's rotation cycle. While toe clips and straps give some benefit with any kind of shoe, they work most effectively with cycling shoes designed for use with toe clips. Your local bicycle dealer can explain how toe clips and straps work. Shoes with deep treaded soles or welts which might make it more difficult for you to insert or remove your foot should not be used with toe clips and straps.

WARNING

Getting into and out of pedals with toe clips and straps requires skill which can only be acquired with practice. Until it becomes a reflex action, the technique requires concentration which can divert attention and cause you to lose control and fall. Practice the use of toe clips and straps where there are no obstacles, hazards or traffic. Keep the straps loose until your technique and confidence in getting in and out of the pedals warrants it. Never ride in traffic with your toe straps tight.

4. Clipless pedals (also called "step-in pedals") are another means to secure feet in a position for maximum pedalling efficiency. They have a plate, called a "cleat," on the sole of the shoe, which clicks into a mating spring-loaded fixture on the pedal. They only engage or disengage with a very specific motion which must be practiced until it becomes instinctive. Clipless pedals require shoes and cleats which are compatible with the make and model pedal being used. Many clipless pedals are designed to allow the rider to adjust the amount of force needed to engage or disengage the foot. Follow the pedal manufacturer's instructions, or ask your local bicycle dealer to show you how to make this adjustment. Use the easiest setting until engaging and disengaging becomes a reflex action, but always make sure that there is sufficient tension to prevent unintended release of your foot from the pedal.

WARNING

Clipless pedals are intended for use with shoes specifically made to fit them and are designed to firmly keep the foot engaged with the pedal. Do not use shoes which do not engage the pedals correctly.

Practice is required to learn to engage and disengage the foot safely. Until engaging and disengaging becomes a reflex action, the technique requires concentration which can distract your attention and cause you to lose control and fall. Practice engaging and disengaging clipless pedals in a place with no obstacles, hazards or traffic; and be sure to follow the pedal manufacturer's setup and service instructions. If you do not have

the manufacturer's instructions, see your dealer or contact the manufacturer.

4.4 TIRES & TUBES

1. Tires

Bicycle tires are available in many designs and specifications, ranging from general-purpose designs to tires designed to perform best under very specific weather or terrain conditions. If, once you've gained experience with your new bike, you feel that a different tire might better suit your riding needs, your local bicycle dealer or Darkside customer service can help you select the most appropriate design.

The size, pressure rating, and on some high-performance tires the specific recommended use, are marked on the sidewall of the tire (see fig. 15). The part of this information which is most important to you is Tire Pressure. The best and safest way to inflate a bicycle tire to the correct pressure is with a bicycle pump which has a built-in pressure gauge.

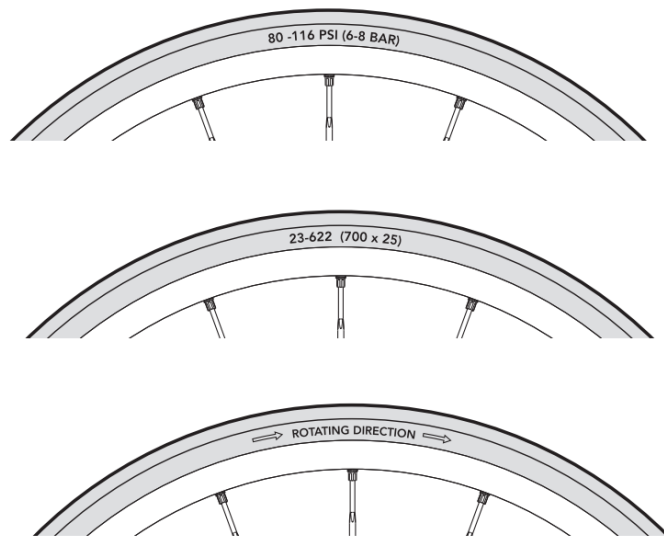

fig. 15

⚠ WARNING

Never inflate a tire beyond the maximum pressure marked on the tire's sidewall. Exceeding the recommended maximum pressure may blow the tire off the rim, which could cause damage to the bike and injury to the rider and bystanders.

Tire pressure is given either as maximum pressure or as a pressure range. How a tire performs under different terrain or weather conditions depends largely on tire pressure. Inflating the tire to near its maximum recommended pressure gives the lowest rolling resistance; but also produces the harshest ride. High pressures work best on smooth, dry pavement.

⚠ WARNING

There is a safety risk in using gas station air hoses or other air compressors. They are not made for bicycle tires. They move a large volume of air very rapidly, and will raise the pressure in your tire very rapidly, which could cause the tube to explode.

⚠ CAUTION

Pencil type automotive tire gauges can be inaccurate and should not be relied upon for consistent, accurate pressure readings. Instead, use a high-quality dial gauge.

Very low pressures, at the bottom of the recommended pressure range, give the best performance on smooth, slick terrain such as hard-packed clay, and on deep, loose surfaces such as deep, dry sand.

Tire pressure that is too low for your weight and the riding conditions can cause a puncture of the tube by allowing the tire to deform sufficiently to pinch the inner tube between the rim and the riding surface.

Ask your local bicycle dealer or Darkside customer service to suggest the best tire pressure for the kind of riding you will most often do, and have the local bicycle dealer inflate your tires to that pressure. Then, check inflation as

described in Section 1.3 so you'll know how correctly inflated tires should look and feel when you don't have access to a gauge. Some tires may need to be brought up to pressure every week or two, so it is important to check your tire pressures before every ride.

Some special high-performance tires have unidirectional treads: their tread pattern is designed to work better in one direction than in the other. The sidewall marking of a unidirectional tire will have an arrow showing the correct rotation direction. If your bike has unidirectional tires, be sure that they are mounted to rotate in the correct direction.

2. Tire Valves

There are primarily two kinds of bicycle tube valves: The Schraeder Valve and the Presta Valve. The bicycle pump you use must have the fitting appropriate to the valve stems on your bicycle. **Darkside bicycle wheels are delivered with Presta valves exclusively, see fig.16.**

The **Schraeder valve** (fig. 16a) is like the valve on a car tire. To inflate a Schraeder valve tube, remove the valve cap and clamp the pump fitting onto the end of the valve stem. To let air out of a Schraeder valve, depress the pin in the end of the valve stem with the end of a key or other appropriate object.

The **Presta valve** (fig. 16b) has a narrower diameter and is only found on bicycle tires. To inflate a Presta valve tube using a Presta headed bicycle pump, remove the valve cap; unscrew (counterclockwise) the valve stem lock nut; and push down on the valve stem to free it up. Then push the pump head on to the valve head, and inflate. To inflate a Presta valve with a Schraeder pump fitting, you'll need a Presta adapter (available at your bike shop) which screws on to the valve stem once you've freed up the valve.

The adapter fits into the Schraeder pump fitting. Close the valve after inflation. To let air out of a Presta valve, open up the valve stem lock nut and depress the valve stem.

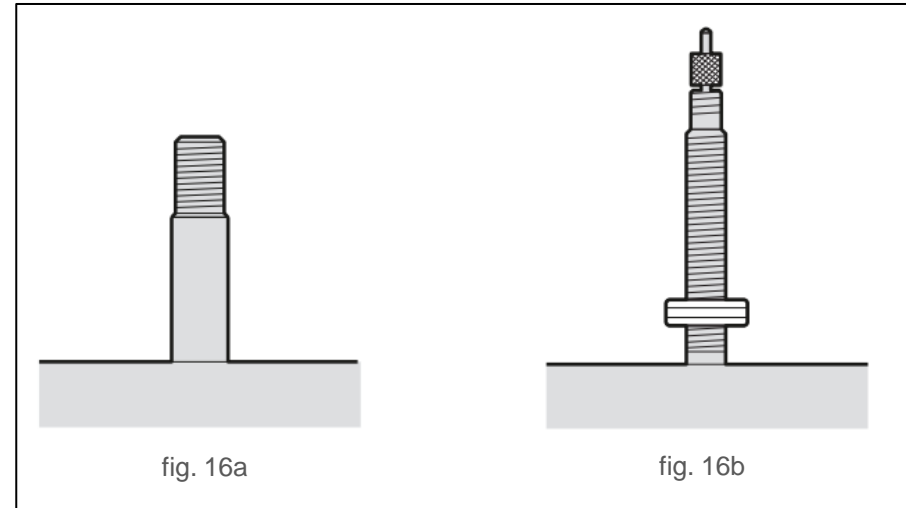

WARNING

We highly recommend that you carry a spare inner tube when you ride your bike. Patching a tube is an emergency repair. If you do not apply the patch correctly or apply several patches, the tube can fail, which could cause you to lose control and fall. Replace a patched tube as soon as possible.

5 SERVICE

WARNING

Technological advances have made bicycles and bicycle components more complex, and the pace of innovation is increasing. It is impossible for this manual to provide all the information required to properly repair and/or maintain your bicycle. In order to help minimize the chances of an accident and possible injury, it is critical that you have any repair or maintenance which is not specifically described in this manual performed by a professional bicycle mechanic. Equally important is that your individual maintenance requirements will be determined by everything from your riding style to geographic location. Consult your local bicycle dealer or Darkside customer service for help in determining your maintenance requirements.

WARNING

Many bicycle service and repair tasks require special knowledge and tools. Do not begin any adjustments or service on your bicycle until you have learned from a professional bicycle mechanic how to properly complete them. Improper adjustment or service may result in damage to the bicycle or in an accident which can cause serious injury or death.

If you want to learn to do major service and repair work on your bike:

1. Ask your dealer for copies of the manufacturer's installation and service instructions for the components on your bike, or contact the component manufacturer.
2. Ask your dealer to recommend a book on bicycle repair.
3. Ask your dealer about the availability of bicycle repair courses in your area.

We recommend that you ask your dealer to check the quality of your work the first time you work on something and before you ride the bike, just to make sure that you did everything correctly. Since that will require the time of a mechanic, there may be a modest charge for this service.

We also recommend that you ask your local bicycle dealer or Darkside customer service for guidance on what spare parts, such as inner tubes, light bulbs, etc. it would be appropriate for you to have once you have learned how to replace such parts when they require replacement.

5.1 SERVICE INTERVALS

Some service and maintenance can and could be performed by the owner, and require no special tools or knowledge beyond what is presented in this manual.

The following are examples of the type of service you should perform yourself. All other service, maintenance and repair should be performed in a properly equipped facility by a qualified bicycle mechanic using the correct tools and procedures specified by the manufacturer.

1. **Break-in Period:** Your bike will last longer and work better if you break it in before riding it hard. Control cables and wheel spokes may stretch or "seat" when a new bike is first used and may require readjustment by a professional bicycle mechanic. Your Mechanical Safety Check (Section 1.3) will help you identify some things that need readjustment. But even if everything seems fine to you, it's best to take your bike back to your local bicycle dealer / professional bicycle mechanic for a check-up. Local bicycle dealers / professional bicycle mechanics typically suggest you bring the bike in for a 30-day check-up. Another way to judge when it's time for the first check-up is to bring the bike in after three to five hours of hard off-road use, or about 10 to 15 hours of on-road or more casual off-road use. But if you think something is wrong with the bike, take it to your local bicycle dealer or contact Darkside customer service before riding it again.
2. **Before every ride:** Mechanical Safety Check (Section 1.3)
3. **After every long or hard ride:** if the bike has been exposed to water or grit; or at least every 100 miles: Clean the bike and lightly lubricate the chain's rollers with a good quality bicycle chain lubricant. Wipe off excess

lubricant with a lint-free cloth. Lubrication is a function of climate. Talk to your local bicycle dealer / professional bicycle mechanic about the best lubricants and the recommended lubrication frequency for your area.

4. After every long or hard ride or after every 10 to 20 hours of riding:

- Squeeze the front brake and rock the bike forward and back. Everything feel solid? If you feel a clunk with each forward or backward movement of the bike, you probably have a loose headset. Have a professional bicycle mechanic check it.
- Lift the front wheel off the ground and swing it from side to side. Feel smooth? If you feel any binding or roughness in the steering, you may have a tight headset. Have a professional bicycle mechanic check it.
- Grab one pedal and rock it toward and away from the centreline of the bike; then do the same with the other pedal. Anything feel loose? If so, have a professional bicycle mechanic check it.
- Take a look at the brake pads. Starting to look worn or not hitting the wheel rim squarely? Time to have a professional bicycle mechanic adjust or replace them.
- Carefully check the control cables and cable housings. Any rust? Kinks? Fraying? If so, have a professional bicycle mechanic replace them.
- Squeeze each adjoining pair of spokes on either side of each wheel between your thumb and index finger. Do they all feel about the same? If any feel loose, have a professional bicycle mechanic check the wheel for tension and trueness.
- Check the tires for excess wear, cuts or bruises. Have a professional bicycle mechanic replace them if necessary.
- Check the wheel rims for excess wear, dings, dents and scratches. Consult a professional bicycle mechanic if you see any rim damage.
- Check to make sure that all parts and accessories are still secure, and tighten any which are not.
- Check the frame, particularly in the area around all tube joints; the handlebars; the stem; and the seatpost for any deep scratches, cracks or discoloration. These are signs of stress-caused fatigue and

indicate that a part is at the end of its useful life and needs to be replaced. See also Appendix B.

WARNING

Like any mechanical device, a bicycle and its components are subject to wear and stress. Different materials and mechanisms wear or fatigue from stress at different rates and have different life cycles. If a component's life cycle is exceeded, the component can suddenly and catastrophically fail, causing serious injury or death to the rider. Scratches, cracks, fraying and discoloration are signs of stress-caused fatigue and indicate that a part is at the end of its useful life and needs to be replaced. While the materials and workmanship of your bicycle or of individual components may be covered by a warranty for a specified period of time by the manufacturer, this is no guarantee that the product will last the term of the warranty. Product life is often related to the kind of riding you do and to the treatment to which you submit the bicycle. The bicycle's warranty is not meant to suggest that the bicycle cannot be broken or will last forever. It only means that the bicycle is covered subject to the terms of the warranty. Please be sure to read Appendix A, Intended Use of Your Bicycle and Appendix B, The Lifespan of Your Bike & Its Components, starting on page 36.

As required: If either brake lever fails the Mechanical Safety Check (Section 1.3), don't ride the bike. Have a professional bicycle mechanic check the brakes.

If the chain won't shift smoothly and quietly from gear to gear, the derailleur is out of adjustment. See your local bicycle shop / professional bicycle mechanic.

Every 25 (hard off-road) to 50 (on-road) hours of riding: Take your bike to your local bicycle shop / professional bicycle mechanic for a complete check-up. Fork inspection must include removal of the fork from the bicycle to permit inspection of the fork steerer as well as the fork blades and dropouts for any signs of damage.

5.2 IF YOUR BICYCLE SUSTAINS AN IMPACT

First, check yourself for injuries, and take care of them as best you can. Seek medical help if necessary.

Next, check your bike for damage.

After any crash, take your bike to a professional bicycle mechanic for a thorough check. Carbon composite components, including frame and fork, wheels, handlebars, stems, cranksets, brakes, etc. which have sustained an impact must **not** be ridden until they have been disassembled and thoroughly inspected by a qualified mechanic. Fork inspection must include removal of the fork from the bicycle to permit inspection of the fork steerer as well as the fork blades and dropouts for any signs of damage.

See also Appendix B, Lifespan Of Your Bike & Its Components.

 **WARNING**

A crash or other impact can put extraordinary stress on bicycle components, causing them to fatigue prematurely. Components suffering from stress fatigue can fail suddenly and catastrophically, causing loss of control, serious injury or death.

This page has been left blank intentionally.

6 PARTS IDENTIFICATION

Darkside Road Bike

Get to know the parts of your bicycle (fig. 17). This will help with assembly, maintenance, and troubleshooting. Colour, style and parts may vary.

No.	Part name	No.	Part name	No.	Part Name
1	Handlebar stem	10	Front fork	19	Seat tube
2	Handlebar	11	Spoke	20	Top tube
3	Handlebar clamp bolt	12	Wheel rim	21	Seat
4	Hand brake	13	Front tire	22	Seat post
5	Brake cable	14	Pedal	23	Seat clamp
6	Front brake	15	Crank arm	24	Seat clamp bolt
7	Head tube	16	Chain wheel	25	Chain
8	Stem clamp bolt	17	Air valve stem	26	Sprocket or Freewheel
9	Headset	18	Down tube		



fig. 17

7 ASSEMBLY

WARNING

Improper assembly of this product may result in serious injury or death. Always follow the instructions in this manual and check critical components (e.g. wheels, seat, pedals, brakes, tires) before each use.

It is strongly recommended to perform the assembly and fitting operations by a professional bicycle mechanic, as it requires specific knowledge of each part, appropriate tools, and understanding of the interactions of various materials. Your bicycle is a high-performance machine, and as such requires skilled maintenance in order to function safely and effectively.

We recommend that you consult a bicycle specialist if you have doubts or concerns as to your experience or ability to properly assemble, repair, or maintain your bicycle. If your bicycle was obtained assembled, we recommend that you read these instructions and perform checks specified in this manual before riding.

Your new bicycle was assembled and tuned in the factory and then partially disassembled for shipping. You may have purchased the bicycle already fully assembled and ready to ride or in the shipping carton in the partially disassembled form. The following instructions will enable you to prepare your bicycle for years of enjoyable cycling. For more details on inspection, lubrication, maintenance and adjustment of any area please refer to the relevant sections in this manual. If you have doubts about your ability to properly assemble this bicycle, we urge you to have the assembly done by a professional bicycle mechanic. If you need replacement parts or have questions pertaining to the assembly of your bicycle, please contact the Darkside Customer Service. Monday - Friday 9:00 am to 5:00 pm Central European Time (CET). Contact data, please see www.darksidebicycle.com.

7.1 TOOLS REQUIRED

Depending on bike model and equipment, you will need the following tools for assembly:

- 4 mm, 5 mm, 6 mm, 8 mm Allen (hex) keys
- Accurate torque wrench with
 - 4 mm, 5 mm, 6 mm and 8 mm hex drive
 - 15 mm socket wrench insert
- 15 mm open-ended spanner
- 15 mm Pedal wrench
- Non-lithium type grease
- Carbon assembly compound
- bicycle air pump with integrated pressure gauge (pressure gauge up to 8 bar)

7.2 GETTING STARTED

- Open the carton from the top and remove the bicycle parts.
- Remove the straps and protective packaging from the bicycle. Important! Do not discard packing materials until assembly is complete to ensure that no required parts are accidentally discarded.
- Inspect the bicycle and all accessories and parts for possible shortages. It is recommended that the threads and all moving parts in the parts package be lubricated prior to installation.
- Please keep the bicycles shipping box. The shipping box is needed if you want to use the Darkside bicycles service at a later date.

7.3 INCLUDED BICYCLE PARTS

The following components and accessories are included with Darkside bicycles (fig. 18).

Note: The bicycle parts will vary depending on your model and construction year. Pedals are not included. Ensure you have all the following parts.

No.	Part name	Qty.
1	Handlebar (with installed brake levers)	1
2	Front wheel with axle nuts	1
3	Main frame (with installed brakes)	1
4	Seat post & saddle	1
5	Carbon assembly compound, 5-6 g	1



fig. 18

7.4 ATTACH THE CARBON SEAT POST

⚠ WARNING

Improperly adjusted seat height could affect the rider's ability to reach the handlebar and pedals resulting in unexpected movement, loss of control and serious injury or death. Follow these guidelines when adjusting the seat height. Always ensure the seat post minimum insertion marks are below the seat clamp and cannot be seen. Ensure the seat clamp is locked and the seat cannot move.

Check the seat tube (1) opening and slot (2) carefully for sharp edges or burrs (see fig. 19). Anything that can scratch, score, gouge, or cut the seat post can cause serious damage leading to breakage of the seat post. Sharp edges or burrs can be removed by hand by lightly sanding with a very fine sandpaper (400 grit). The seat tube opening and -slot should feel very smooth without jagged edges or nicks.

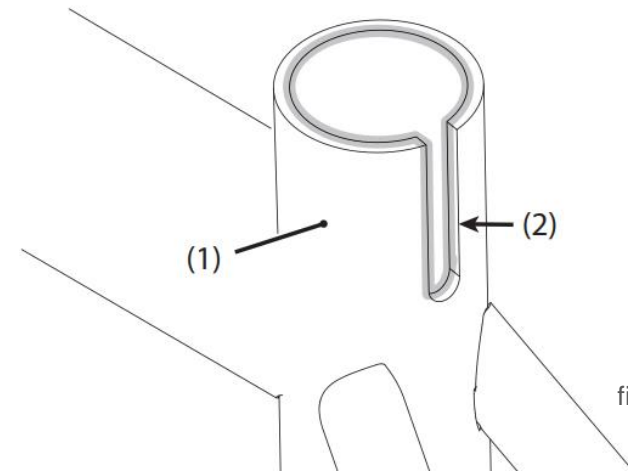

fig. 19

The seat assembly should be adjusted with the seat centered on the rails and level. It is recommended to add some grease to all threads and binders on a bicycle. Otherwise it may corrode over time and not be able to be adjusted again.

ASSEMBLY

Parts: Carbon seat post & seat,
Main frame with installed fork

Tools: Allen wrench 5mm,
Accurate Torque wrench with 5 mm hex drive,
Carbon assembly compound,
Grease

A: Adjust and mark the correct seat height (see fig. 20).

- 1 Loosen the seat clamp bolt with a 5 mm Allen wrench
- 2 Adjust the seat height up or down until the rider feels they have control of the bicycle and is comfortable. **Important!** Be sure the **minimum insertion marks** do not go past the top of the seat clamp and are not visible. See Section 3.2, Fig. 3 & 4: Seat Height and Handlebar Reach.

Mark the adjusted height temporary with tape on the seat post.

B: Lock the seat in place (see fig. 20).

- 1 Loosen the seat clamp bolt with a 5 mm Allen wrench
- 2 Remove the seat post from the seat tube
- 3 Clean & degrease the inside of the seat tube and the outside of the seat post mounting area.
- 4 Apply small amount of carbon assembly compound on the inside of the seat tube and the outside of the seat post mounting area.
- 5 Insert the seat post into the seat tube up to the marking (tape). Make sure the seat is aligned parallel with the top tube of the bike frame.
- 6 Tighten the seat clamp bolt only *with an **Accurate Torque Wrench***. To determine correct tightening torque, see Appendix C or marking.
- 7 Check the seat to be sure it does not move.
- 8 Remove the tape from the seat post (temporary height marking). Remove excess carbon assembly compound with a cleaning cloth.

WARNING

Do not overtighten the seat clamp bolt. Overtighten may cause the failure of a seat post, resulting in an accident and/or serious injury or death.

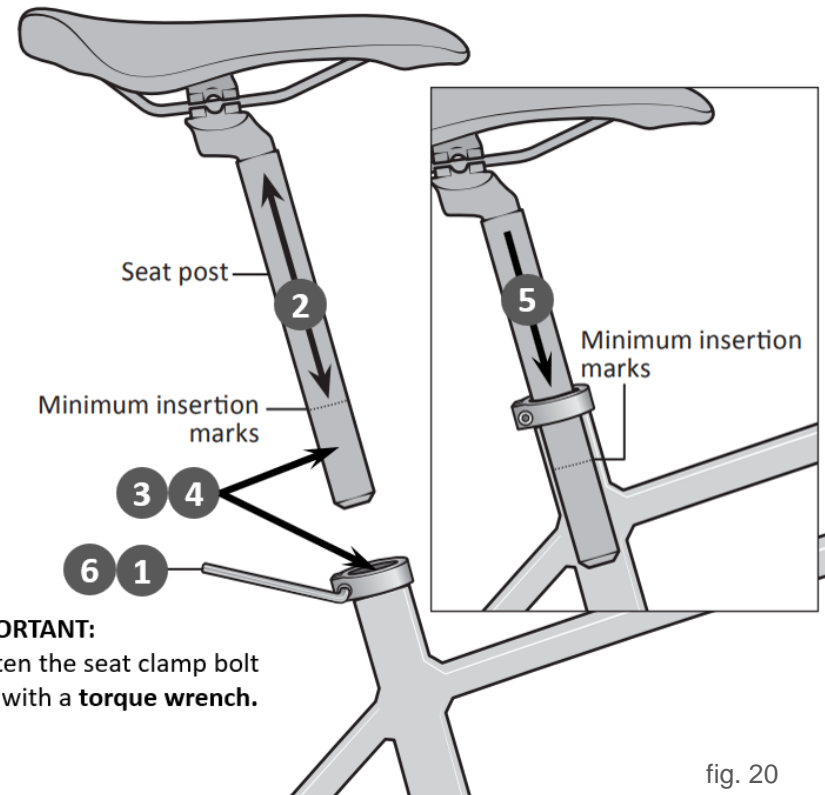

IMPORTANT:
Tighten the seat clamp bolt
only with a **torque wrench**.

fig. 20

7.5 PLACING THE BICYCLE IN A WORK STAND

The clamping jaws of a bike stand can generate a crushing force strong enough to seriously damage your frame. See fig. 21.

CAUTION

Never place your bike in a bike stand by clamping the frame.

Place your bike in a stand by extending the seat post and positioning the stand clamp on the extended seat post. Don't extend beyond the **MINIMUM INSERT** line marked on the seat post.

Since your carbon seat post can also be damaged by clamping force, adjust the stand clamp for the minimum clamping force needed to secure the bike.

Also, before clamping, clean the post and protect the seat post finish with a rag.

RECOMMENDATION: To protect the carbon seat post surface from scratches, use a soft cotton cloth between the clamping jaws and the seat post.

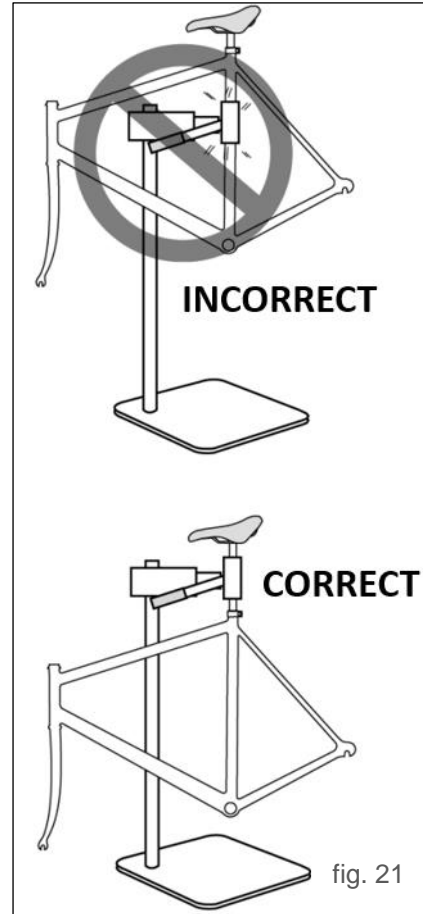

7.6 ATTACH THE FRONT WHEEL

WARNING

Failure to properly tighten the nuts holding the wheels onto the tricycle may result in poor riding performance, the tire falling off and serious injury or death. Be sure the wheels are securely attached to the frame before using the tricycle.

Parts: Front wheel,
Main frame with installed fork

Tools: Accurate Torque wrench with 15 mm socket wrench insert

Note: Tire tread patterns have a direction, compare your front tire and rear tire of the bicycle so that both tread patterns face the same direction.

Front wheel with bolt-on wheel, see fig. 22:

- 1 Loosen the axle nut of the front wheel on either side to about 90%.
- 2 Open the quick-release mechanism of the front brake. See section 4.2 BRAKES, fig. 13.
- 3 With the steering fork facing forward, place the front wheel into the fork openings. Be sure both sides of the axle rest on the fork and the wheel is centered.
- 4 Loosely tighten the axle nut on either side.
- 5 Check that the wheel is centered, and inspect the wheel for even rotation.
- 6 Tighten each axle nut with an **Accurate Torque Wrench** according to the torque specifications in Appendix C.
- 7 **CLOSE** the quick-release mechanism of the front brake (See section 4.2 BRAKES, fig. 13.)!

⚠ WARNING

When the brake quick release is in the open position, the brakes are **inoperative!**

- 8 Check the air pressure on the front and rear wheels and inflate the tires if necessary, see section 4.4. The tire pressure recommended by the manufacturer can usually be found on the tire sidewall or the type label. **NOTE:** The tire pressure must not be higher than 8 bar.

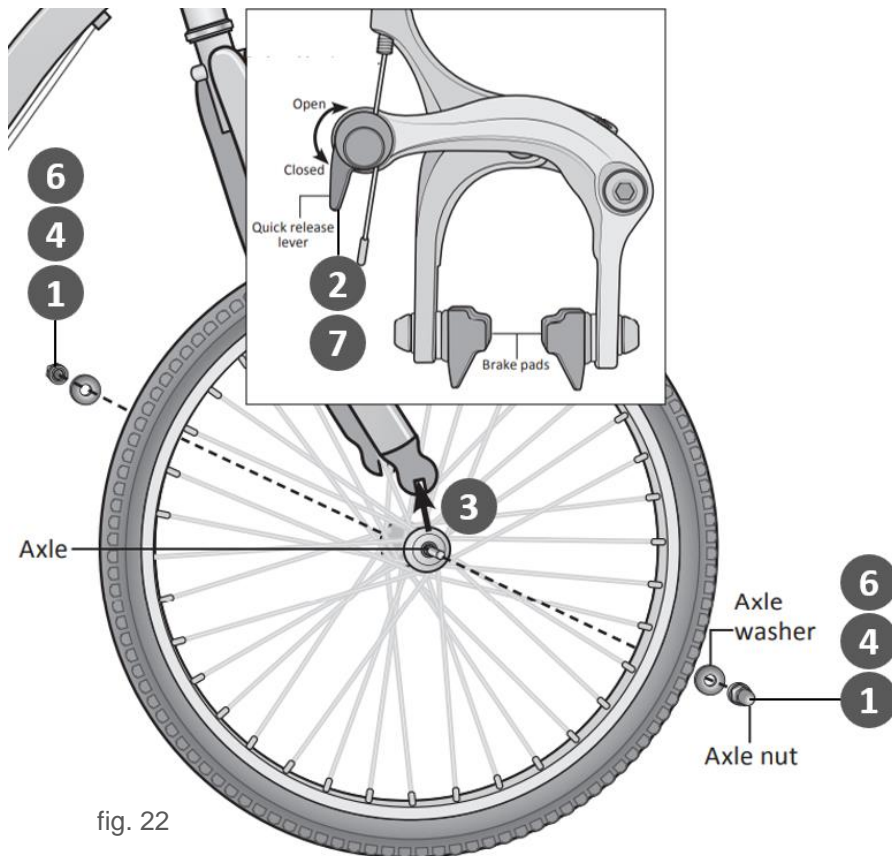

fig. 22

7.7 ATTACH THE HANDLEBAR**⚠ WARNING**

Failure to properly tighten handlebar components may result in loss of control, serious injury or death. Always check the handlebar cannot move and is secured to the frame before riding the bicycle.

Parts: Handlebar (with installed brake levers),
Main frame with installed fork

Tools: Allen wrench 4mm,
Accurate Torque wrench with 4 mm, 5 mm hex drive,
Carbon assembly compound

NOTE: Screw 12 (see fig. 23) on the A-head cap is not used to tighten the stem, but only to adjust the bearing clearance!

- 1 Turn the front fork & the stem to face forward, fig. 23
- 2 Loosen and remove the pinch bolts holding the face plate on the front of the stem. Remove the handle bar from the stem.
- 3 Clean & degrease the inside of the stem mounting area and the outside of the handlebar mounting area.
- 4 Apply small amount of carbon assembly compound on the inside of the stem mounting area and the outside of the handlebar mounting area.
- 5 Apply a small amount of grease to the threads of the bolts before threading them back into the stem.
- 6 Place the handlebar into the back place.
- 7 Place the face plate over the handlebar. Make sure the bowden cables and the lines are not twisted or bent, but run in a smooth curve to the cable stops or brakes.
- 8 Begin threading the pinch bolts into the stem body. Loosely tighten the pinch bolts in a cross pattern so you can still adjust handlebar.

- 9 Look down the handlebar and stem and make sure the stem is centered with the center of the tire and fork. Adjust the tilt of the handlebars to a position that suits you.
- 10 Tighten the pinch bolts with an **Accurate Torque Wrench** gradually, according to the torque specifications in Appendix C, in a cross pattern. Do not overtighten the bolts. As you tighten the bolts the gap between the face plate and the stem body should be the same all around.
- 11 Check the headset play by pulling the front brake and moving the bike back and forth. There should be no noticeable headset play.

If you can still feel headset play, turn the headset play adjustment screw clockwise a quarter turn.
- 12 Check the headset play again and repeat step 11 as necessary until there is no headset play. Note that the handlebars must still **move smoothly! Don't overtighten the screw on the A-head cap!**

⚠ WARNING

Please note that it is not allowed to increase the factory-specified spacer height under the stem.

⚠ WARNING

Important note regarding the Darkside Flat bar:

- Installation of bar ends is not allowed.
- Shortening the flat bar is not allowed.

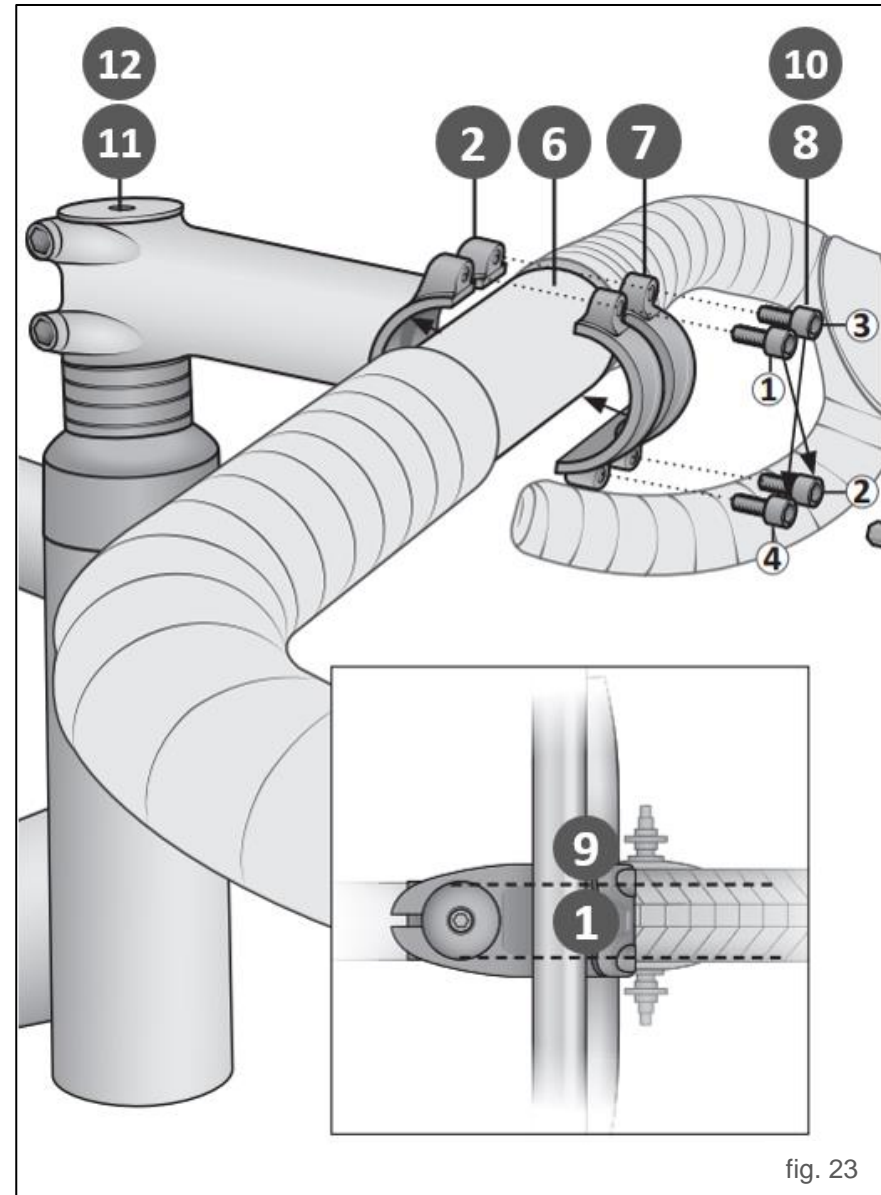

7.8 ATTACH THE PEDALS

WARNING

Attachment of an incorrect pedal into a crank arm can strip pedal threads and cause irreparable damage. Visually match the R and L stickers on the pedal and crank arm before attaching the pedals. Before your first ride, please check to ensure your pedals are attached correctly.

It is very important that you check the crank set for correct adjustment and tightness before riding your bicycle.

Parts: Pedals (are not included with Darkside bicycles)

Tools: 15 mm Pedal wrench,
Non-lithium type grease

- 1 Match the pedal marked R with the right-hand crank arm and match the pedal marked L with the left-hand crank arm.
- 2 Apply a small amount of grease to each pedal thread and crank arm hole and the, see fig. 23.
- 3 Check if your pedals were supplied with washers and slide both washers onto the pedal axles – if present, see fig. 23.
- 4 Place the threaded pedal into the hole on the crank arm, see fig. 23.
- 5 By hand, slowly turn the spindle the correct direction. Clockwise for right side pedal, counterclockwise for left side pedal. Important! Stop if you feel resistance! This may be an indication the spindle is entering the hole at an angle. Remove the spindle and repeat step four, see fig. 23.
- 6 If the spindle is entering the hole cleanly then use a 15 mm pedal wrench and tighten both pedals to a torque of 30 to 35 Nm (to determine correct tightening torque refer to pedal manufacturer's instructions for installation), see fig. 23.
- 7 Tighten the crank axle nuts using an appropriate wrench.

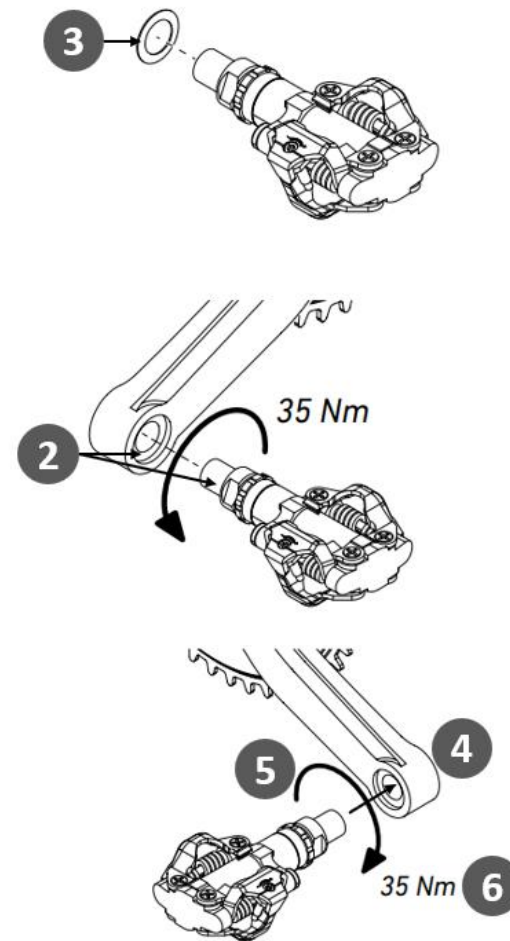

fig. 23

Your bike is now completely assembled. Before riding off, you should follow the steps in section 1 FIRST, section 2 SAFETY and section 3 FIT.

APPENDIX

APPENDIX A - INTENDED USE OF YOUR BICYCLE

⚠ WARNING

Understand your bike and its intended use. Choosing the wrong bicycle for your purpose can be hazardous. Using your bicycle the wrong way is dangerous.

No one type of bicycle is suited for all purposes. Darkside customer service can help you pick the “right tool for the job” and help you understand its limitations. There are many types of bicycles and many variations within each type. There are many types of mountain, road, racing, hybrid, touring, cyclocross and tandem bicycles. There are also bicycles that mix features. For example, there are road/racing bikes with triple cranks. These bikes have the low gearing of a touring bike, the quick handling of a racing bike, but are not well suited for carrying heavy loads on a tour. For that purpose, you want a touring bike.

Within each of type of bicycle, one can optimize for certain purposes. Visit your bicycle shop and find someone with expertise in the area that interests you. Do your own homework. Seemingly small changes such as the choice of tires can improve or diminish the performance of a bicycle for a certain purpose. On the following pages, we generally outline the intended uses of the various types of Darkside bikes.

NOTE: Usage conditions are generalized and evolving. Contact Darkside customer service about how you intend to use your bike.

NOTE: Maximum weight limits are estimates based on several factors which may vary including but not limited to, riding style, road and terrain conditions and weight distribution. It is never advisable to continue to load the bicycle to its maximum capacity. If you have questions regarding the use of your bicycle at its maximum capacity please contact the Darskide customer service.

Maximum Weight Limit – All Darkside Bicycle Models

Rider	Luggage/Gear*	Total
105 kg	5 kg	110 kg
231,5 lbs	11 lbs	242,5 lbs

*Seat bag / water bottles / bento bag / handlebar bottle / storage mounts only

High-Performance Road - Condition 1

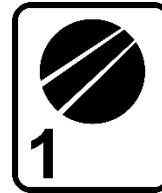

Bikes designed for riding on a paved surface where the tires do not lose ground contact.

Intended: To be ridden on paved roads only.

Not Intended: For off-road, cyclocross, touring with racks or panniers, or mounting child seats or trailers.

Trade-Off: Material use is optimized to deliver both light weight and specific performance. You must understand that (1) these types of bikes are intended to give an aggressive racer or competitive cyclist a performance advantage over a relatively short product life, (2) a less aggressive rider will enjoy longer frame life, (3) you are choosing light weight (shorter frame life) over more frame weight and a longer frame life, (4) you are choosing light weight over more dent resistant or rugged frames that weigh more. All frames that are very light need frequent inspection. These frames are likely to be damaged or broken in a crash. They are not designed to take abuse or be a rugged workhorse. See also Appendix B.

Applicable Darkside Models: Mannheim Track One, Mannheim Track Two, Mannheim Urban One, Mannheim Urban Two

General Purpose Riding - Condition 2

Bikes designed for riding Condition 1, plus smooth gravel roads and improved trails with moderate grades where the tires do not lose ground contact.

Intended: For paved roads, gravel or dirt roads that are in good condition, and bike paths.

Not Intended: For off-road or mountain bike use, or any kind of jumping. While some have suspension features, these features are designed to add comfort, not off-road capability. Some come with relatively wide tires, well suited to gravel or dirt paths. Some come with relatively narrow tires, best suited to faster riding on pavement. If you ride on gravel or dirt paths, carry heavier loads or want more tire durability contact Darkside customer service about wider tires. Not intended for touring with racks or panniers, or mounting child seats or trailers. See also Appendix B.

Applicable Darkside Models: None

Gravel/Cyclocross - Condition 3

Bikes designed for riding Conditions 1 and 2, plus smooth gravel roads and improved trails with moderate grades where the tires do not lose ground contact.

Intended: For cyclocross riding, training and racing. Cyclocross involves riding on a variety of terrain and surfaces including dirt or mud surfaces. Cyclocross bikes also work well for all-weather rough road riding and commuting.

Not Intended: For off-road or mountain bike use, or jumping. Cyclocross riders and racers dismount before reaching an obstacle, carry their bike over the obstacle, and then remount. Cyclocross bikes are not intended for mountain bike use. The relatively large road bike size wheels are faster than the smaller mountain bike wheels, but not as strong. See also Appendix B.

Applicable Darkside Models: None

This page has been left blank intentionally.

APPENDIX B - THE LIFESPAN OF YOUR BICYCLE

1. NOTHING LASTS FOREVER, INCLUDING YOUR BIKE

When the useful life of your bike or its components is over, continued use is hazardous.

Every bicycle and its component parts have a finite, limited useful life. The length of that life will vary with the construction and materials used in the frame and components; the maintenance and care the frame and components receive over their life; and the type and amount of use to which the frame and components are subjected. Use in competitive events, trick riding, ramp riding, jumping, aggressive riding, riding on severe terrain, riding in severe climates, riding with heavy loads, commercial activities and other types of non-standard use can dramatically shorten the life of the frame and components. Any one or a combination of these conditions may result in an unpredictable failure.

All aspects of use being identical, lightweight bicycles and their components will usually have a shorter life than heavier bicycles and their components. In selecting a lightweight bicycle or components you are making a trade-off, favouring the higher performance that comes with lighter weight over longevity. So, if you choose lightweight, high performance equipment, be sure to have it inspected frequently.

You should have your bicycle and its components checked periodically by a professional bicycle mechanic for indicators of stress and/or potential failure, including cracks, deformation, corrosion, paint peeling, dents, and any other indicators of potential problems, inappropriate use or abuse. These are important safety checks and very important to help prevent accidents, bodily injury to the rider and shortened product life.

2. PERSPECTIVE

Today's high-performance bicycles require frequent and careful inspection and service. In this Appendix we try to explain some underlying material science basics and how they relate to your bicycle. We discuss some of the trade-offs made in designing your bicycle and what you can expect from your bicycle; and we provide important, basic guidelines on how to maintain and

inspect it. We cannot teach you everything you need to know to properly inspect and service your bicycle; and that is why we repeatedly urge you to take your bicycle to a professional bicycle mechanic for professional care and attention.

WARNING

Frequent inspection of your bike is important to your safety. Follow the Mechanical Safety Check in Section 1.3 of this Manual before every ride.

Periodic, more detailed inspection of your bicycle is important. How often this more detailed inspection is needed depends upon you.

You, the rider/owner, have control and knowledge of how often you use your bike, how hard you use it and where you use it. Because Darkside Bicycles cannot track your use, you must take responsibility for periodically bringing your bike to your local bicycle shop / professional bicycle mechanic for inspection and service. Your local bicycle shop / professional bicycle mechanic will help you decide what frequency of inspection and service is appropriate for how and where you use your bike.

For your safety, understanding and communication with your local bicycle shop / professional bicycle mechanic, we urge you to read this Appendix in its entirety. The materials used to make your bike determine how and how frequently to inspect.

Ignoring this WARNING can lead to frame, fork or other component failure, which can result in serious injury or death.

2.1 Understanding Metals

Steel is the traditional material for building bicycle frames. It has good characteristics, but in high performance bicycles, steel has been largely replaced by aluminium and some titanium. The main factor driving this change is interest by cycling enthusiasts in lighter bicycles.

APPENDIX

Properties of Metals

Please understand that there is no simple statement that can be made that characterizes the use of different metals for bicycles. What is true is how the metal chosen is applied is much more important than the material alone. One must look at the way the bike is designed, tested, manufactured, supported along with the characteristics of the metal rather than seeking a simplistic answer.

Metals vary widely in their resistance to corrosion. Steel must be protected or rust will attack it. Aluminium and Titanium quickly develop an oxide film that protects the metal from further corrosion. Both are therefore quite resistant to corrosion. Aluminium is not perfectly corrosion resistant, and particular care must be used where it contacts other metals and galvanic corrosion can occur.

Metals are comparatively ductile. Ductile means bending, buckling and stretching before breaking. Generally speaking, of the common bicycle frame building materials steel is the most ductile, titanium less ductile, followed by aluminium.

Metals vary in density. Density is weight per unit of material. Steel weighs 7.8 grams/cm³ (grams per cubic centimetre), titanium 4.5 grams/cm³, aluminium 2.75 grams/cm³. Contrast these numbers with carbon fiber composite at 1.45 grams/cm³.

Metals are subject to fatigue. With enough cycles of use, at high enough loads, metals will eventually develop cracks that lead to failure. It is very important that you read The Basics of Metal Fatigue below.

Let's say you hit a curb, ditch, rock, car, another cyclist or other object. At any speed above a fast walk, your body will continue to move forward, momentum carrying you over the front of the bike. You cannot and will not stay on the bike, and what happens to the frame, fork and other components is irrelevant to what happens to your body.

What should you expect from your metal frame? It depends on many complex factors, which is why we tell you that crashworthiness cannot be a design criteria. With that important note, we can tell you that if the impact is hard enough the fork or frame may be bent or buckled. On a steel bike, the steel fork may be severely bent and the frame undamaged. Aluminium is less ductile than steel, but you can expect the fork and frame to be bent or buckled. Hit harder and the top tube may be broken in tension and the down tube

buckled. Hit harder and the top tube may be broken, the down tube buckled and broken, leaving the head tube and fork separated from the main triangle. When a metal bike crashes, you will usually see some evidence of this ductility in bent, buckled or folded metal.

It is now common for the main frame to be made of metal and the fork of carbon fiber. See Section 2.2 Understanding Composites below. The relative ductility of metals and the lack of ductility of carbon fiber means that in a crash scenario you can expect some bending or bucking in the metal but none in the carbon. Below some load the carbon fork may be intact even though the frame is damaged. Above some load the carbon fork will be completely broken.

The Basics of Metal Fatigue

Common sense tells us that nothing that is used lasts forever. The more you use something, and the harder you use it, and the worse the conditions you use it in, the shorter its life.

Fatigue is the term used to describe accumulated damage to a part caused by repeated loading. To cause fatigue damage, the load the part receives must be great enough. A crude, often-used example is bending a paper clip back and forth (repeated loading) until it breaks. This simple definition will help you understand that fatigue has nothing to do with time or age. A bicycle in a garage does not fatigue. Fatigue happens only through use. So what kind of "damage" are we talking about? On a microscopic level, a crack forms in a highly stressed area. As the load is repeatedly applied, the crack grows. At some point the crack becomes visible to the naked eye. Eventually it becomes so large that the part is too weak to carry the load that it could carry without the crack. At that point there can be a complete and immediate failure of the part.

One can design a part that is so strong that fatigue life is nearly infinite. This requires a lot of material and a lot of weight. Any structure that must be light and strong will have a finite fatigue life. Aircraft, race cars, motorcycles all have parts with finite fatigue lives. If you wanted a bicycle with an infinite fatigue life, it would weigh far more than any bicycle sold today. So we all make a trade-off: the wonderful, lightweight performance we want requires that we inspect the structure.

In most cases a fatigue crack is not a defect. It is a sign that the part has been worn out, a sign the part has reached the end of its useful life. When your car tires wear down to the point that the tread bars are contacting the road, those tires are not defective. Those tires are worn out and the tread bar says “time for replacement.” When a metal part shows a fatigue crack, it is worn out. The crack says “time for replacement.”

Metal Fatigue – What To Look For	
Once a crack starts it can grow and grow fast. Think about the crack as forming a pathway to failure. This means that any crack is potentially dangerous and will only become more dangerous.	Simple Rule 1: If you find crack, replace the part.
Corrosion speeds damage. Cracks grow more quickly when they are in a corrosive environment. Think about the corrosive solution as further weakening and extending the crack.	Simple Rule 2: Clean your bike, lubricate your bike, protect your bike from salt, remove any salt as soon as you can.
Stains and discoloration can occur near a crack. Such staining may be a warning sign that a crack exists.	Simple Rule 3: Inspect and investigate staining to see if it is associated with a crack.
Significant scratches, gouges, dents or scoring create starting points for cracks. A cut surface is a focal point for stress. Perhaps you have seen glass cut? Recall how the glass was scored and then broke on the scored line.	Simple Rule 4: Do not scratch, gouge or score any surface. If you do, pay frequent attention to this area or replace the part.
Some cracks (particularly larger ones) may make creaking noise as you ride. Think about such a noise as a serious warning signal. Note that a well-maintained bicycle will be very quiet and free of creaks and squeaks.	Simple Rule 5: Find the source of any noise. It may not be a crack, but the cause of the noise should be fixed promptly.

Fatigue is Not a Perfectly Predictable Science

Fatigue is not a perfectly predictable science, but here are some general factors to help you and your local bicycle shop determine how often your bicycle should be inspected. The more you fit the “shorten product life” profile, the more frequent your need to inspect. The more you fit the “lengthen product life” profile, the less frequent your need to inspect.

Factors that shorten product life:

- Hard, harsh riding style
- “Hits”, crashes, jumps, other “shots” to the bike
- High mileage
- Higher body weight
- Stronger, more fit, more aggressive rider
- Corrosive environment (wet, salt air, winter road salt, accumulated sweat)
- Presence of abrasive mud, dirt, sand, soil in riding environment

Factors that lengthen product life:

- Smooth, fluid riding style
- No “hits”, crashes, jumps, other “shots” to the bike
- Low mileage
- Lower body weight
- Less aggressive rider
- Non-corrosive environment (dry, salt-free air)
- Clean riding environment

 **WARNING**

Do not ride a bicycle or component with any crack, bulge or dent, even a small one. Riding a cracked frame, fork or component could lead to complete failure, with risk of serious injury or death.

2.2 Understanding Composites (Carbon Fiber)

All riders must understand a fundamental reality of composites. Composite materials constructed of carbon fibers are strong and light, but when crashed or overloaded, **carbon fibers do not bend, they break.**

What Are Composites?

The term “composites” refers to the fact that a part or parts are made up of different components or materials. You’ve heard the term “carbon fiber bike.” This really means “composite bike.”

Carbon fiber composites are typically a strong, light fiber in a matrix of plastic, molded to form a shape. Carbon composites are light relative to metals. Steel weighs 7.8 grams/cm³ (grams per cubic centimeter), titanium 4.5 grams/cm³, aluminium 2.75 grams/cm³. Contrast these numbers with carbon fiber composite at 1.45 grams/cm³.

The composites with the best strength-to-weight ratios are made of carbon fiber in a matrix of epoxy plastic. The epoxy matrix bonds the carbon fibers together, transfers load to other fibers, and provides a smooth outer surface. The carbon fibers are the “skeleton” that carries the load.

Why Are Composites Used?

Unlike metals, which have uniform properties in all directions (engineers call this isotropic), carbon fibers can be placed in specific orientations to optimize the structure for particular loads. The choice of where to place the carbon fibers gives engineers a powerful tool to create strong, light bicycles. Engineers may also orient fibers to suit other goals such as comfort and vibration damping.

Carbon fiber composites are very corrosion resistant, much more so than most metals. Think about carbon fiber or fiberglass boats. Carbon fiber materials have a very high strength-to-weight ratio.

What Are The Limits Of Composites?

Well designed “composite” or carbon fiber bicycles and components have long fatigue lives, usually better than their metal equivalents.

While fatigue life is an advantage of carbon fiber, you must still regularly inspect your carbon fiber frame, fork, or components.

Carbon fiber composites are not ductile. Once a carbon structure is overloaded, it will not bend; it will break. At and near the break, there will be rough, sharp edges and maybe delamination of carbon fiber or carbon fiber fabric layers. There will be no bending, buckling, or stretching.

While carbon fibers themselves are very strong and temperature resistant, high temperatures can damage the plastic matrix portion of the composite. Prolonged exposure to temperatures above 65°C/149°F can affect the integrity of the composite structure.

WARNING

Do not expose your bicycle to temperatures above 65°C/149°F for any extended period of time. It is possible to reach this temperature while the bicycle is in storage or transport, such as the inside of a car parked in the sun. Take care to avoid confined storage areas with exposure to sources of heat.

If You Hit Something or Have A Crash, What Can You Expect From Your Carbon Fiber Bike?

Let’s say you hit a curb, ditch, rock, car, other cyclist or other object. At any speed above a fast walk, your body will continue to move forward, the momentum carrying you over the front of the bike. You cannot and will not stay on the bike and what happens to the frame, fork and other components is irrelevant to what happens to your body.

What should you expect from your carbon frame? It depends on many complex factors. But we can tell you that if the impact is hard enough, the fork or frame may be completely broken. Note the significant difference in behavior between carbon and metal. See Section 2.1, Understanding metals in this Appendix. Even if the carbon frame was twice as strong as a metal frame, once the carbon frame is overloaded it will not bend, it will break completely.

WARNING

Never use clamping devices on the tubes of carbon frames. Clamps such as those found on bicycle work stands and car racks can cause serious damage to the carbon frame.

2.3 Inspection of Composite Frame, Fork, & Components

Cracks

Inspect for cracks, broken, or splintered areas. Any crack is serious. Do not ride any bicycle or component that has a crack of any size.

Delamination

Delamination is serious damage. Composites are made from layers of fabric. Delamination means that the layers of fabric are no longer bonded together. Do not ride any bicycle or component that has any delamination.

These are some delamination clues:

1. A cloudy or white area. This kind of area looks different from the ordinary undamaged areas. Undamaged areas will look glassy, shiny, or “deep,” as if one was looking into a clear liquid. Delaminated areas will look opaque and cloudy.
2. Bulging or deformed shape. If delamination occurs, the surface shape may change. The surface may have a bump, a bulge, soft spot, or not be smooth and fair.
3. A difference in sound when tapping the surface. If you gently tap the surface of an undamaged composite you will hear a consistent sound, usually a hard, sharp sound. If you then tap a delaminated area, you will hear a different sound, usually duller, less sharp.



WARNING

Do not ride a bicycle or component with any delamination or crack. Riding a delaminated or cracked frame, fork or other component could lead to complete failure, with risk of serious injury or death.

Unusual Noises

Either a crack or delamination can cause creaking noises while riding. Think about such a noise as a serious warning signal. A well maintained bicycle will be very quiet and free of creaks and squeaks. Investigate and find the source of any noise. It may not be a crack or delamination, but whatever is causing the noise must be fixed before riding.

2.4 Understanding Components

It is often necessary to remove and disassemble components in order to properly and carefully inspect them. **This is a job for a professional bicycle mechanic** with the special tools, skills and experience to inspect and service today’s high-tech high-performance bicycles and their components.

Aftermarket “Super Light” Components

Think carefully about your rider profile as outlined above. The more you fit the “shorten product life” profile, the more you must question the use of super light components. The more you fit the “lengthen product life” profile, the more likely it is that lighter components may be suitable for you. Discuss your needs and your profile very honestly with your dealer. Take these choices seriously and understand that you are responsible for the changes.

A useful slogan to discuss with your dealer if you contemplate changing components is “Strong, Light, Cheap – pick two.”

Original Equipment Components

Bicycle and component manufacturers test the fatigue life of the components that are original equipment on your bike. This means that they have met test criteria and have reasonable fatigue life. It does not mean that the original components will last forever. They won’t.

APPENDIX C – TORQUE SPECIFICATIONS

Correct tightening torque of threaded fasteners is very important to your safety. Always tighten fasteners to the correct torque. In case of a conflict between the instructions in this manual and information provided by a component manufacturer, consult Darkside customer service for clarification. Bolts that are too tight can stretch and deform. Bolts that are too loose can move and fatigue. Either mistake can lead to a sudden failure of the bolt.

Always use a correctly calibrated torque wrench to tighten critical fasteners on your bike. Carefully follow the torque wrench manufacturer's instructions on the correct way to set and use the torque wrench for accurate results. Ensure you read all applicable documentation and have the correct tools prior to attempting any adjustments yourself.

It is recommended that you permit your local bicycle dealer / professional bicycle mechanic to perform the following adjustments, as they have the proper tools and experience to ensure it is done correctly.

Note that prior to assembling and tightening any bolts, all threads must be generously greased with a quality, non-lithium type grease unless the bolt is pre-coated with Loctite® thread locker. All bolts should have either grease or Loctite® - but never both. Torque wrenches with scale appropriate for the particular torque setting are strongly recommended for tightening all threaded fasteners.

In addition to bolts, it is mandatory to grease the following:

- Both upper and lower headtube bearing cups
- Seat post clamp (underneath for collar style, and for wedge style grease is applied between the sliding surfaces)
- Bottom bracket cups
- Front and rear axles

Darkside strongly recommends the use of carbon assembly compound/ friction paste for all areas of clamping to carbon fiber, such as the seat post to frame, the stem to fork, and the handlebar to stem joints. Benefits to using this paste include reduced corrosion potential, and a decrease in required clamping force needed to support a given load. The paste should be evenly

spread on the carbon surface under the clamped area, and the applicable bolt tightened as per the following recommendations.

WARNING

In case of a disagreement or a conflict between the following list and any supplier literature on recommended torque values for original equipment components, please contact Darkside Customer Service for review and clarification of the required torque prior to installation.

APPENDIX

Tightening Torque Information for Your Bike

To determine correct tightening torque for a fastener we ask you also to check:

- Markings on the component. Many components are marked. On-product marking is becoming common.
- Torque specs in the component manufacturers instructions shipped with your bicycle.
- Torque specs listed on the websites of component manufacturers.

Component		Torque (Nm)	Note
Frame	Bottom bracket BSA 68	35 to 40 Nm	Clean & grease the inside of the BB shell in the frame Grease the outside of the BB cups
	Crank attachment system	45 to 50 Nm	
Brake	Brake lever to carbon handlebar	3 to 6 Nm	Brake levers must not move.
	Cable clamp bolt	6 to 7 Nm	
	Pad fixing bolt for caliper brake	5 Nm	Brake pads must not move (rotate)
Pedals	Pedals	35 Nm	Refer to manufacturer's instructions for installation of pedals
Wheels	Front axle nuts (bolt-on wheel)	21 Nm	
	Rear axle nuts (bolt-on wheel)	30 Nm	
Stem	Stem to carbon handlebar (4 bolts)	6 Nm	Lightly grease bolts Use carbon assembly compound between the stem and the handlebar
	Stem to fork steerer tube	5 to 6 Nm	Use carbon assembly compound between the stem and the steerer tube
	Headset adjustment screw	1 to 2 Nm	Apply enough torque to remove play while ensuring free rotation of the headset
Seat Post	Seat post Clamp (frame to seat post)	6 Nm	Use carbon assembly compound between the seat post and the frame
	Carbon saddle fixing bolt (2 bolts)	7 – 8 Nm	Saddle must not move.

APPENDIX D – PURCHASE RECORD

IMPORTANT: Write down your Darkside bicycle model and serial number for your records. Put your sales receipt or proof of purchase in this manual for reference. This record will also help you with any police investigation or insurance claim.

FIRST & LAST NAME: _____

ADDRESS: _____

ZIP CODE: _____

CITY: _____

COUNTRY: _____

E-MAIL: _____

PHONE NUMBER: _____

MODEL NAME: _____

FRAME COLOR: _____

SERIAL NUMBER: _____

INVOICE NUMBER: _____

PURCHASE DATE: _____

NOTE: We did not record individual of serial numbers, if those are not register at Darkside Bicycles. If there is a loss or theft, your personal records will be needed. Your sale receipt should be kept for any warranty service.

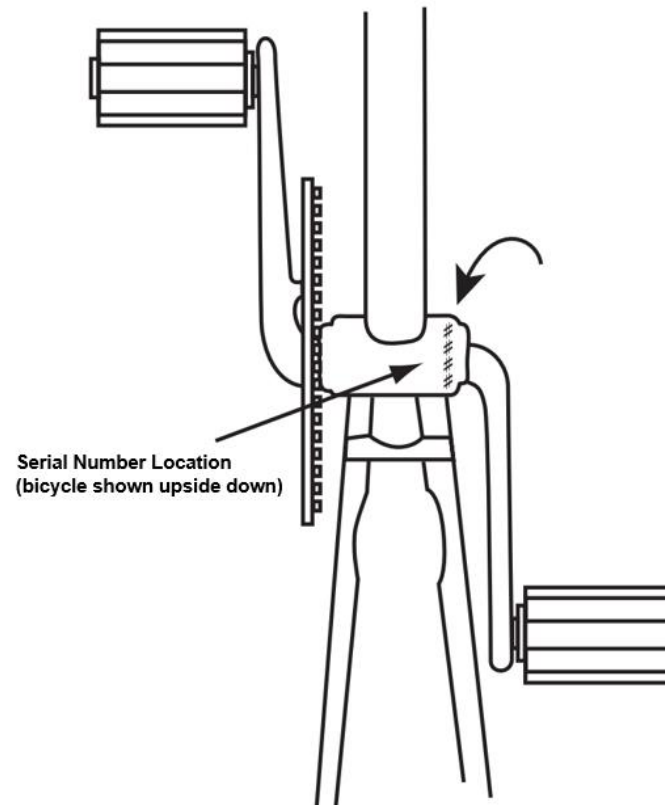

APPENDIX E – WARRANTY AND GUARANTEE

You now own a high-quality Darkside Bicycle, designed and manufactured with the utmost care. According to the European warranty conditions the warranty period is two years from the date of delivery to the customer. As proof of purchase, please retain the sales receipt for the duration of the warranty. Keep the sales receipt in a safe place. In addition to the general two-year period of warranty, a reverse burden of proof is in effect for a period of six months following the purchase. After this period, the buyer has to prove that the fault was already present when the product was delivered and was not in fact caused by improper maintenance, use, wear and tear. If you have any questions, please call the Darkside customer service.

- Two-years warranty from date of delivery
- Warranty covers only material defects and processing errors that are already existed on delivery

Additional to the statutory warranty, a voluntary guarantee of 2 years is granted on frames and forks. Your guarantee will only be activated after your registration and after we have received your proof of professional assembly. This guarantee is only valid for the original purchaser and is not transferable. Should the product be transferred to another person, this warranty expires. The warranty is at our discretion by replacement or repair of parts recognized as defective using identical or comparable parts, depending on the state of technical development. Work carried out under the guarantee does not give rise to an extension of the warranty, unless national legislation provides for specific provisions in this respect. The shipping costs for the return shipping are to be borne by the buyer.

The warranty does not cover:

- Maintenance (lubrication, adjustment) or all parts subject to functional wear and tear as far as there is no production or material failure (tires, tubes, brake pads, freewheels, sprockets, chainring, chains, bar tape, grips, saddle, brake cables, Brake cable housings, seals, etc.)
- Damage caused by improper handling (see Appendix A Intended Use Of Your Bicycle) or by excess force.
- Damage caused by improper or poor maintenance and care, non-professional repairs, rebuilding or replacements of parts.

- Damage caused by accidents or other abnormal interferences as far they are not traced back to product failures.
- Repairs with used parts, or following damages due to this.
- Damage caused under competitive circumstances.
- Subsequent additional parts which are not included in the scope of delivery at the date of delivery, or damages caused while assembling these parts.

NOTE:

Surface irregularities on carbon components (small boils and pores) and/or colour irregularities (especially with UD carbon) are unavoidable for manufacturing reasons. This doesn't represent a defect (or reason for complaint).



WARNING

Unprofessional assembly or insufficient maintenance can render the bicycle unsafe. Risk of an accident.

1. ACTIVATE YOUR BICYCLE GUARANTEE

Your guarantee will only be activated after received your proof of professional assembly. This procedure will ensure the safest and most optimized riding experience possible with your new bicycle. Darkside Bicycles must receive your guarantee request and proof of professional build within 30 days of you receiving your bicycle.

Please note: We only have your bicycles serial number on file if you register it with us. Your serial number is engraved on the under-side of the bottom bracket shell on each frame (see APPENDIX D – PURCHASE RECORD).

1. Arrange a professional assembly of your bicycle at your local bicycle dealer.
2. After completion of the installation, please obtain a certificate of professional installation. For example, a receipt or invoice for the work performed.
3. Fill out and submit the online form:
see website ***www.darksidebicycles.com***

NOTE: Darkside Bicycles does not cover the cost of professional assembly.

This page has been left blank intentionally.

PRE-RIDE CHECKLIST

Are you wearing a helmet and other appropriate equipment and clothing, such as protective glasses and gloves? Do not wear loose clothing that could become entangled in the bicycle (See section 2.1 The Basics).

Are your seatpost and stem securely fastened? Twist the handlebars firmly from side to side while holding the front wheel between your knees. The stem must not move in the steering tube. Similarly, the seat post must be secure in the seat tube (See section 3 Fit).

Are you visible to motorists? If you are riding at dusk, dawn or at night, you must make yourself visible to motorists. Use front and rear lights and a strobe or blinker. Reflectors alone do not provide adequate visibility. Wear reflective clothing (See section 2.5 Night Riding and section 2.2 Riding Safety).

Is it raining or wet? If so, be more cautious. Your braking distances will increase, and your tires' grip on the road will decrease. Remember that motorists' visibility decreases with bad weather (See section 2.4 Wet Weather Riding and section 2.2 Riding Safety).

Are your tires properly inflated? Tires must be inflated to the recommended pressure. (See section 4.4 Tires and Tubes).

Are your wheels true? Lift each end of the bike and spin each wheel. Does the space between the rim and the brake pads, or the tire and the frame, remain nearly the same size as the wheel turns? Are your spokes tight? (See Section 1.3 Mechanical Safety Check).

Are your wheels' quick-releases and/or axle nuts properly fastened? Be sure to read the section on proper operation of quick-release skewers and wheel axle nuts (See Section 4.1 Wheels).

Are your front and rear brakes functioning properly? With Linear-pull-brakes (V-brakes), the quick release "noodle" must be properly installed. With cantilever brakes, the quick release straddle cable must be properly attached. With caliper brakes the quick release lever must be closed. With any rim brake, the brake pads must make firm contact with the rim without the brake levers hitting the handlebar grip (See Section 4.2 Brakes). With hydraulic disc brakes, check that the lever feels firm, does not move too close to the handlebar grip, and there is no evidence of leaking brake fluid. With cable actuated disc brakes, check that the lever feels firm and does not move too close to the handlebar grip. With any disc brakes, the brake pads must make firm contact with the rotor without the brake levers hitting the handlebar grip (See Section 4.2 Brakes).

How do your clipless pedals work today? Clip in and out of your pedals before you begin. Experienced cyclists do. The connection between cleat and pedal is affected by dozens of factors including dirt, mud, lubrication, spring tension and wear. By clipping in and out you will check the function and have a fresh memory of how they feel (See Section 4.3 Pedals).

How recently were your frame, fork and components inspected? Never ride a frame, fork or components with any crack or damage. (See Section 5 Service and Appendix B The Lifespan Of Your Bicycle And It's Components).

WARNING

FOLLOW THIS CHECKLIST BEFORE EVERY RIDE. IF YOU HAVE ANY REASON TO SUSPECT THAT YOUR BICYCLE IS NOT FUNCTIONING PROPERLY, DO NOT RIDE IT. Have it inspected by a professional bicycle mechanic. Failure to follow this checklist and to have any potential problem inspected could lead to an accident, with risk of serious injury, paralysis or death!