

# 7400/7401 Dimensions

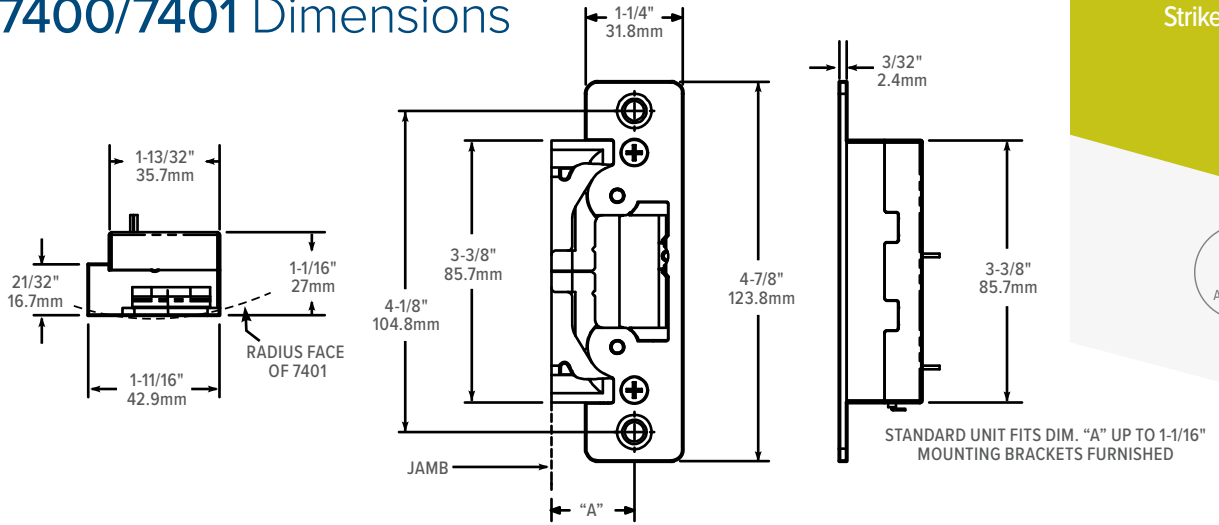

## Jamb Preparation

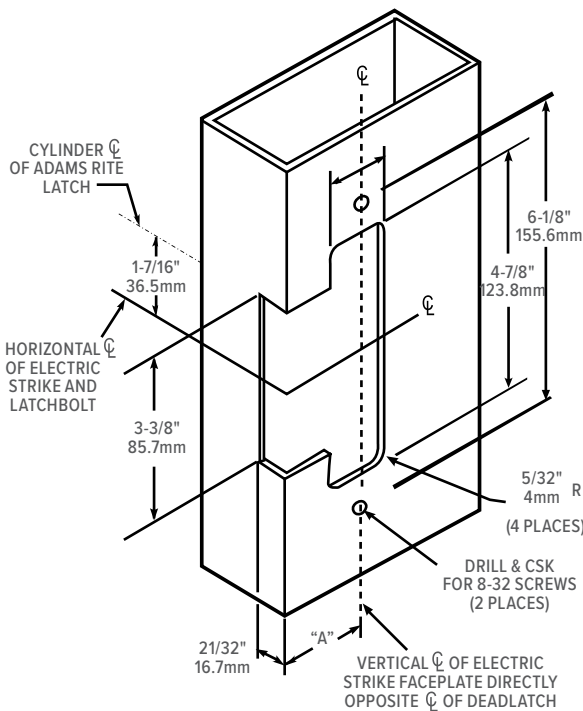

## Installation

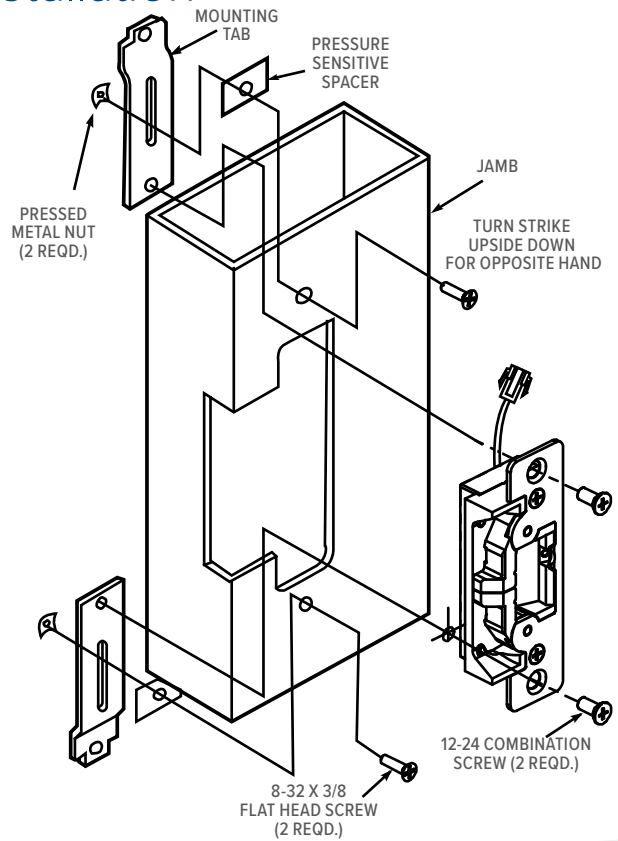

## How to Order

7400/7401 Electric Strikes: Specify quantity and the following information. Order related products separately.

MODEL	FACEPLATE SHAPE	FEATURES*	FINISH		
740	O	M	628		628
			7400 ONLY		7401 ONLY
	0 Flat	- None			
	1 Radius	M Monitored	313 Dark Bronze Anodized	626 Satin Chrome	119 To match 335 Black Anodized
		A Modular Pack – Body Kit	335 Black Anodized	628 Clear Anodized	121 To match 313 Dark Bronze Anodized
			605 Bright Brass	630 Satin Stainless	130 To match 628 Clear Anodized
			606 Satin Brass		

\*Fail-secure can be field converted to fail-safe or vice-versa.