

80 Series Parts Manual



For assistance, contact SARGENT at
800-727-5477 or www.sargentlock.com

Experience a safer
and more open world

Copyright © 2017-2021, SARGENT Manufacturing Company. All rights reserved. Reproduction in whole or in part without the express written permission of SARGENT Manufacturing Company is prohibited.

 **WARNING**

This product can expose you to lead which is known to the state of California to cause cancer and birth defects or other reproductive harm. For more information go to www.P65warnings.ca.gov.

A82311L 04/21

Item	Part No.	Description	Qty	Sellable
1	97-3230	16- Cylinder Dogging Assembly	1	Yes
2	68-0767	F Wide Rail Insert ²	1	Yes
	68-0768	E Wide Rail Insert ²		Yes
	68-0769	G Wide Rail Insert ²		Yes
	68-0770	G Narrow J Wide Rail Insert ²		Yes
	68-1376	E and F Narrow Rail Insert ²		Yes
	68-1465	J Narrow Rail Insert ²		Yes
3	13-2131	Cylinder Ring Assembly ²	1	Yes
4	68-6040	Retaining Collar Assembly	1	Yes
5	N/A	Cylinder and Key Assembly ¹	1	Yes
N/A	01-0288	Allen Wrench	1	Yes

- 1. For Cylinder, Specify "Mortise" Cylinder, Finish and Keying Requirements
- 2. Specify Finish

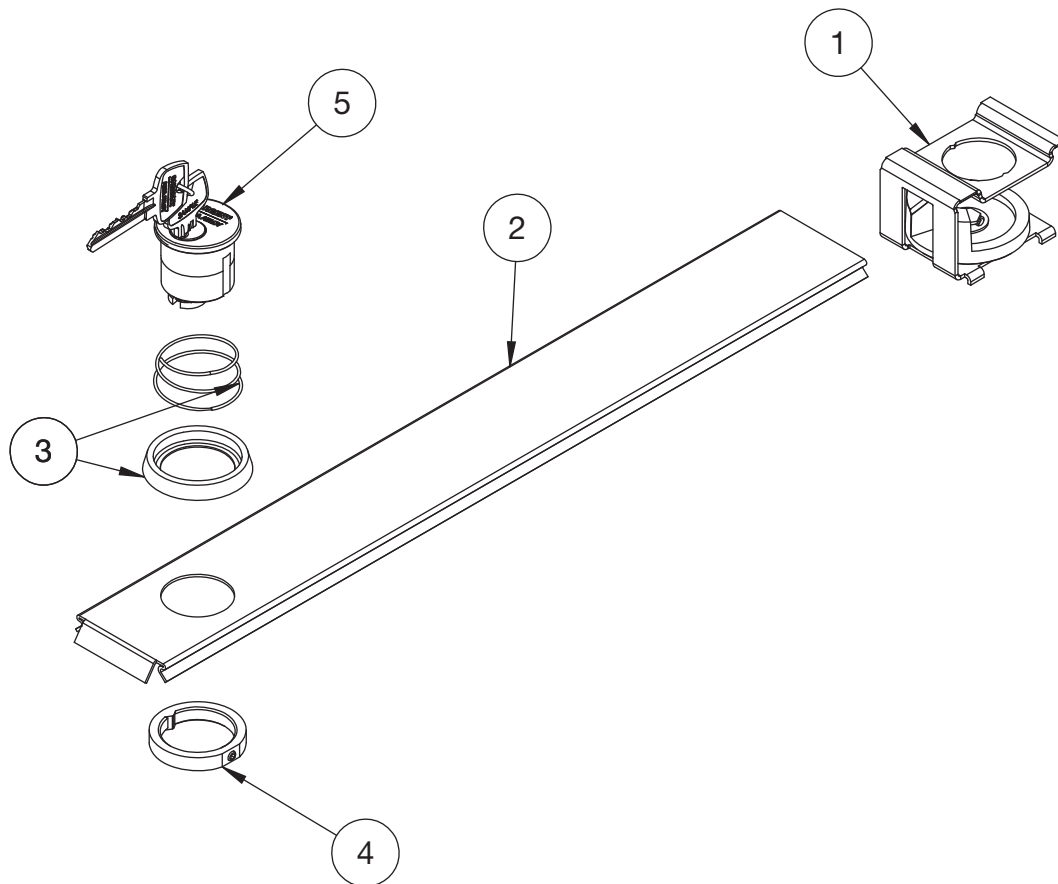

A8231L 04/21

The warranty on SARGENT® products becomes void if the product is modified in any way, regardless of whether the modification causes or contributes to any alleged defect. If a SARGENT product is modified it may no longer meet industry certification and quality control standards applicable to the original product and is no longer a genuine SARGENT product.