

SARGENT®

ASSA ABLOY

80 Series Parts Manual



For assistance, contact SARGENT at
800-727-5477 or www.sargentlock.com

Copyright © 2017, Sargent Manufacturing Company, an ASSA ABLOY Group company. All rights reserved.
Reproduction in whole or in part without the express written permission of Sargent Manufacturing Company is prohibited.

ASSA ABLOY, the global leader
in door opening solutions

Table of Contents



Chassis Assemblies

- 83004
- 8400 5-10
- 8500 11-12
- 8600 13-28
- 8700 29-52
- 8800 53-67
- 8900 68-69

900 Series Mortise Locks 70-82

Rail Assemblies 83-102

700 Series ET Control 103-133

Auxiliary Controls 134-136

The warranty on SARGENT® products becomes void if the product is modified in any way, regardless of whether the modification causes or contributes to any alleged defect. If a SARGENT product is modified it may no longer meet industry certification and quality control standards applicable to the original product and is no longer a genuine SARGENT product.

Copyright ©2017 Sargent Manufacturing Company, an ASSA ABLOY Group company. All rights reserved. Reproduction in whole or in part without the express written permission of Sargent Manufacturing Company is prohibited.

STD	8706	8710	8713	8715
	8728	8740	8743	8746
	8762	8763	8773	8774

SARGENT
ASSA ABLOY

Function	Assembly No.	Description	Sellable
(All Functions)	97-2434 Manufactured Before 11/11/2002	Top Case Assembly	Yes
	68-4557 Manufactured After 11/11/2002		Yes

Item	Assy No.	Part No.	Description	Qty	Sellable
1	N/A	97-0018	Top Cover*	1	Yes
2		68-3905	Screw Pack (B)*	1	Yes
3	97-2434	97-0065	Latch Release Lever Pin	1	Yes
4		97-0579	Spring, Torsion	1	Yes
5		68-1155	Latch Retracting Lever	1	Yes
6		97-0296	Latch Bolt	1	Yes
7		97-0300	L.B. Spring	1	Yes
8		97-0299	Chassis	1	Yes
9		97-0294	Pivot Pin	3	Yes
11		01-0461	Spirol Pin	1	Yes
12		01-0002	Roll Pin	1	Yes
3	68-4557	97-0065	Latch Release Lever Pin	1	Yes
4		97-0579	Spring, Torsion	1	Yes
5		68-1155	Latch Retracting Lever	1	Yes
6		97-0296	Latch Bolt	1	Yes
7		97-0300	L.B. Spring	1	Yes
8		97-0299	Chassis	1	Yes
9		97-0294	Pivot Pin	1	Yes
10		68-1455	Top Rod Adjuster	1	Yes
11		01-0461	Spirol Pin	1	Yes
12		01-0002	Roll Pin	1	Yes
13	N/A	97-0298	Top Slide	1	Yes
14		670T	Top Rod	1	Yes
15		97-0020	Rod Guide*	1	Yes
16	N/A	646	Strike Pack	1	Yes

*Specify Finish

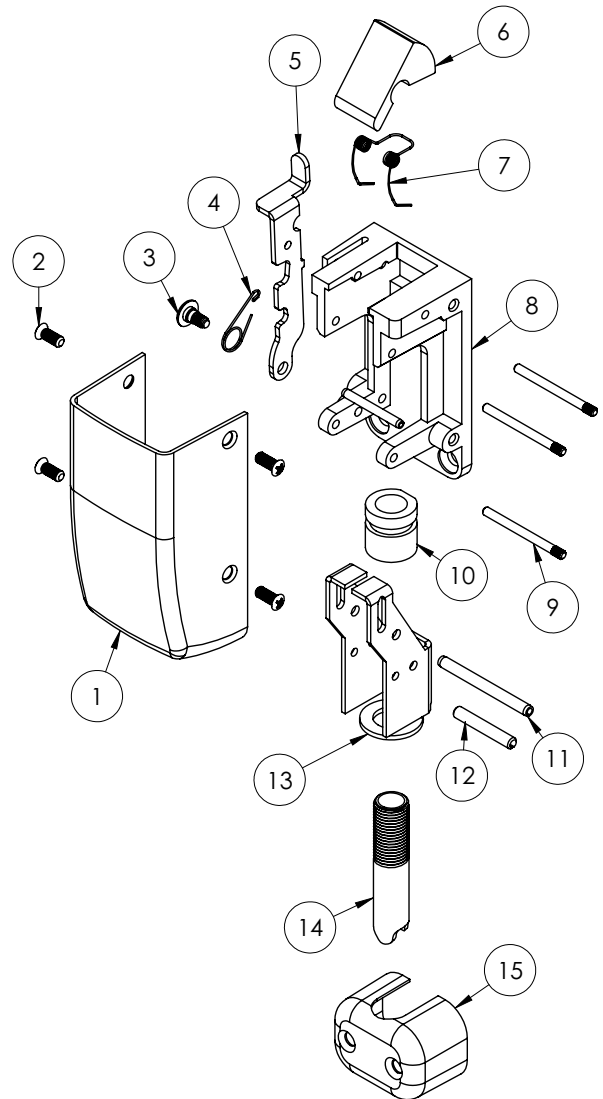

A8231 12/17

The warranty on SARGENT® products becomes void if the product is modified in any way, regardless of whether the modification causes or contributes to any alleged defect. If a SARGENT product is modified it may no longer meet industry certification and quality control standards applicable to the original product and is no longer a genuine SARGENT product.

Copyright ©2017 Sargent Manufacturing Company, an ASSA ABLOY Group company. All rights reserved. Reproduction in whole or in part without the express written permission of Sargent Manufacturing Company is prohibited.

STD **8706** **8710** **8713** **8715**
 8728 **8740** **8743** **8746**
 8762 **8763** **8773** **8774**

Function	Assembly No.	Description	Sellable
(All Functions)	97-2038 (Manufactured Before 11/11/2002)	Bottom Case Assembly	Yes
	68-4549 (Manufactured After 11/11/2002)		Yes

Item	Assy No.	Part No.	Description	Qty	Sellable
1	N/A	97-0018	Bottom Cover*	1	Yes
2		68-3905	Screw Pack (B)*	1	Yes
3	97-2038	97-0035	Retractor	1	Yes
4		97-0084	Adjustment Pin, Bottom Rod	1	Yes
5		97-0025	Bottom Chassis	1	Yes
6		97-0053	Bottom Latch Bolt	1	Yes
7		01-0697	Spirol Pin	1	Yes
3	68-4549	97-0035	Retractor	1	Yes
4		97-0084	Adjustment Pin, Bottom Rod	1	Yes
5		97-0025	Bottom Chassis	1	Yes
6		97-0053	Bottom Latch Bolt	1	Yes
7		01-0697	Spirol Pin	1	Yes
8		97-0572	Rod Adjustment Nut	1	Yes
9	N/A	97-0101	Spring, Compression	1	Yes
10		670B	Bottom Rod	1	Yes
11		97-0020	Rod Guide*	1	Yes
12		624	Bottom Strike Pack	1	Yes

*Specify Finish

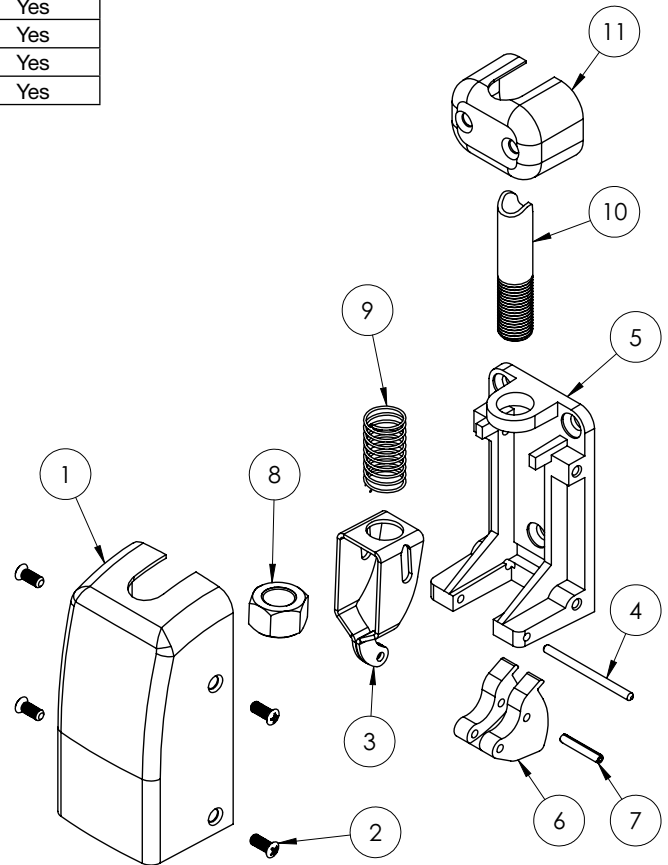

The warranty on SARGENT® products becomes void if the product is modified in any way, regardless of whether the modification causes or contributes to any alleged defect. If a SARGENT product is modified it may no longer meet industry certification and quality control standards applicable to the original product and is no longer a genuine SARGENT product.

Copyright ©2017 Sargent Manufacturing Company, an ASSA ABLOY Group company. All rights reserved. Reproduction in whole or in part without the express written permission of Sargent Manufacturing Company is prohibited.

12-	8706	8710	8713	8715
	8728	8740	8743	8746
	8762	8763	8773	8774

Function	Assembly No.	Description	Sellable
(All Functions)	97-2693	Top Case Assembly	Yes
	Manufactured Before 11/11/2002		
	68-4559		Yes
	Manufactured After 11/11/2002		

Item	Assy No.	Part No.	Description	Qty	Sellable
1	N/A	97-0018	Top Cover*	1	Yes
2		68-3905	Screw Pack (B)*	1	Yes
3	68-4559	97-0065	Latch Release Lever Pin	1	Yes
4		01-0002	Roll Pin	1	Yes
5		01-0461	Spirol Pin	1	Yes
6		97-0579	Spring, Torsion	1	Yes
7		97-0399	Latch Retracting Lever	1	Yes
8		97-0391	Sleeve	2	Yes
9		97-0398	Latch Bolt	1	Yes
10		97-0400	Top Case Spring	1	Yes
11		97-0405	Guard Lever	1	Yes
12		97-0393	Pivot Pin	1	Yes
13		97-0402	Top Chassis	1	Yes
14		97-0394	Latch Bolt Pivot Pin	1	Yes
15		97-0294	Pivot Pin	3	Yes
16		68-1455	Top Rod Adjuster	1	Yes
17	97-0397	Slide	1	Yes	
3	97-2963	97-0065	Latch Release Lever Pin	1	Yes
5		01-0461	Spirol Pin	1	Yes
6		97-0579	Spring, Torsion	1	Yes
7		97-0399	Latch Retracting Lever	1	Yes
8		97-0391	Sleeve	2	No
9		97-0398	Latch Bolt	1	Yes
10		97-0400	Top Case Spring	1	No
11		97-0405	Guard Lever	1	No
12		97-0393	Pivot Pin	1	No
13		97-0402	Top Chassis	1	Yes
14	97-0394	Latch Bolt Pivot Pin	1	Yes	
15	97-0294	Pivot Pin	3	Yes	
17	97-0397	Slide	1	Yes	
18	N/A	670T	Top Rod	1	Yes
19		97-0020	Rod Guide*	1	Yes
20		646	Strike Pack	1	Yes

*Specify Finish

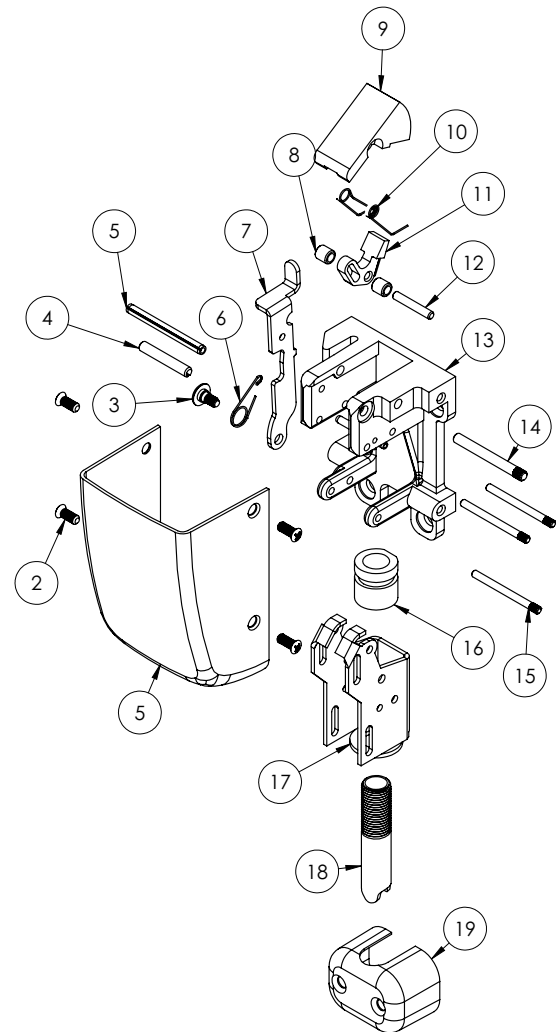

FM, 12-FM	12-	8706	8710	8713	8715
12-HC	12-HC4	8728	8740	8743	8746
HC	HC4	8762	8763	8773	8774

Function	Assembly No.	Description	Sellable
(All Functions)	97-2002	Bottom Case Assembly Manufactured Before 11/11/2002	Yes
	68-4558	Bottom Case Assembly Manufactured After 11/11/2002	Yes

Item	Assy No.	Part No.	Description	Qty	Sellable
1	N/A	97-0018	Bottom Cover*	1	Yes
2		68-3905	Screw Pack (B)*	1	Yes
3	97-2002	97-0076	Bottom Bolt	1	Yes
4		97-0305	Nylon Insert	4	Yes
5		97-0270	Reinforcement	1	Yes
6		97-0101	Spring, Compression	1	Yes
7		97-0080	Chassis	1	Yes
8		01-4404	CR-FH #6 Head 8-32 Screw	2	Yes
3	68-4558	68-1454	Bottom Bolt	1	Yes
4		97-0305	Nylon Insert	4	Yes
5		97-0270	Reinforcement	1	Yes
6		97-0101	Spring, Compression	1	Yes
7		97-0080	Chassis	1	Yes
8	01-4404	CR-FH #6 Head 8-32 Screw	2	Yes	
9	N/A	670B	Bottom Rod	1	Yes
10		97-0020	Rod Guide*	1	Yes
11		655	Flat Strike Pack (STD, HC)	1	Yes
	653	Bottom Strike Pack (FM)	1	Yes	

*Specify Finish

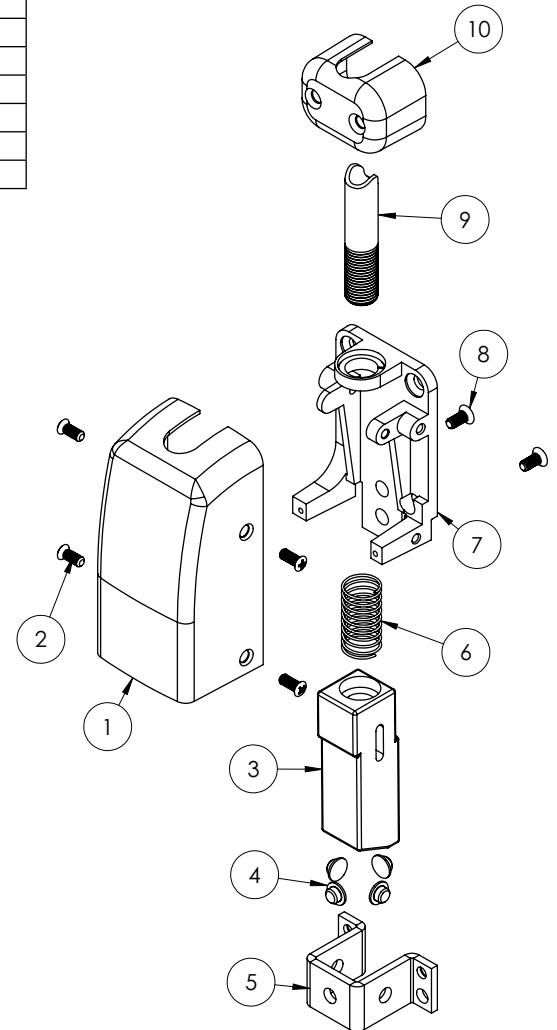

The warranty on SARGENT® products becomes void if the product is modified in any way, regardless of whether the modification causes or contributes to any alleged defect. If a SARGENT product is modified it may no longer meet industry certification and quality control standards applicable to the original product and is no longer a genuine SARGENT product.

Copyright ©2017 Sargent Manufacturing Company, an ASSA ABLOY Group company. All rights reserved. Reproduction in whole or in part without the express written permission of Sargent Manufacturing Company is prohibited.

12-(FM, HC, HC4)
(FM, HC, HC4)

8706	8710	8713	8715
8728	8740	8743	8746
8762	8763	8773	8774

SARGENT
ASSA ABLOY

Function	Assembly No.	Description	Sellable
(All Functions)	97-2003	Top Case Assembly Manufactured Before 11/11/2002	Yes
	68-4561	Top Case Assembly Manufactured After 11/11/2002	Yes

Item	Assy No.	Part No.	Description	Qty	Sellable
1	N/A	97-0084	Top Cover*	1	Yes
2		68-3905	Screw Pack (B)*	1	Yes
3	97-2003	97-0079	Top Case Filler	1	Yes
4		01-1490	#4-40 x 3/8 PH Pan MS	2	Yes
5		97-0579	Spring, Torsion	1	Yes
6		97-0065	Pin, Latch Release Lever	1	Yes
7		01-0695	Spirol Pin	1	Yes
8		97-0270	Top Reinforcement	1	Yes
9		97-2046	Top Slide Assembly	1	Yes
10		68-1155	Latch Release Lever	1	Yes
11		97-0080	Chassis	1	Yes
12		01-0476	Snap-In Nyliner	1	Yes
3	68-4561	97-0079	Top Case Filler	1	Yes
4		01-1490	#4-40 x 3/8 PH Pan MS	2	Yes
5		97-0579	Spring, Torsion	1	Yes
6		97-0065	Pin, Latch Release Lever	1	Yes
7		01-0695	Spirol Pin	1	Yes
8		97-0761	Top Reinforcement	1	Yes
9		68-4560	Top Slide Assembly	1	Yes
10		68-1665	Latch Release Lever	1	Yes
11		97-0080	Chassis	1	Yes
12		01-0476	Snap-In Nyliner	1	Yes
13	N/A	670T	Top Rod	1	Yes
14		97-0020	Rod Guide*	1	Yes
15		659	Strike Pack	1	Yes

*Specify Finish

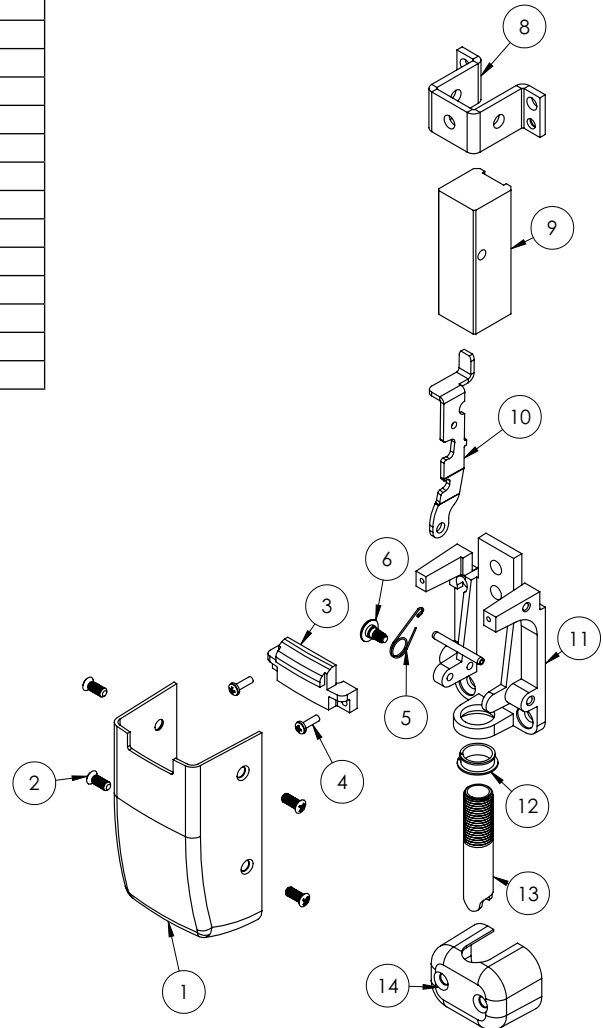

A8231 12/17

The warranty on SARGENT® products becomes void if the product is modified in any way, regardless of whether the modification causes or contributes to any alleged defect. If a SARGENT product is modified it may no longer meet industry certification and quality control standards applicable to the original product and is no longer a genuine SARGENT product.

Copyright ©2017 Sargent Manufacturing Company, an ASSA ABLOY Group company. All rights reserved. Reproduction in whole or in part without the express written permission of Sargent Manufacturing Company is prohibited.

12-NB	8706	8710	8713
NB	8715	8740	8743
	8746	8773	8774

Function	Assembly No.	Description	Sellable
(All Functions)	68-3933	Top Case Assembly	Yes

Item	Assy No.	Part No.	Description	Qty	Sellable	
1	N/A	97-0392	Top Cover*	1	Yes	
2		68-3905	Screw Pack (B)*	1	Yes	
3	68-3933	97-0065	Latch Release Lever Pin	1	Yes	
4		97-0579	Spring, Torsion	1	Yes	
5		68-1155	Latch Retracting Lever	1	Yes	
6		68-1153	Top Case Latch Bolt	1	Yes	
7		01-0697	Spirol Pin	2	Yes	
8		97-0400	Top Case Spring	1	Yes	
9		68-1460	Link, Pivot	1	Yes	
10		97-0402	Top Chassis	1	Yes	
11		97-0394	Pivot Pin, Latch Bolt	1	Yes	
12		01-0461	Spirol Pin	1	Yes	
13		97-0294	Pivot Pin	2	Yes	
14		68-0991	Fusible Link	1	No	
15		68-0419	Guide Spring	1	No	
16		01-3563	#5-40 x 1/4 PH RD HD MS	1	No	
17		68-0420	Pin, Fire Stop	1	No	
18		68-1458	Top Rod Link	1	Yes	
19		N/A	97-0020	Rod Guide*	1	Yes
20		N/A	670T	Top Rod	1	Yes
21	N/A	646	Strike Pack	1	Yes	

*Specify Finish

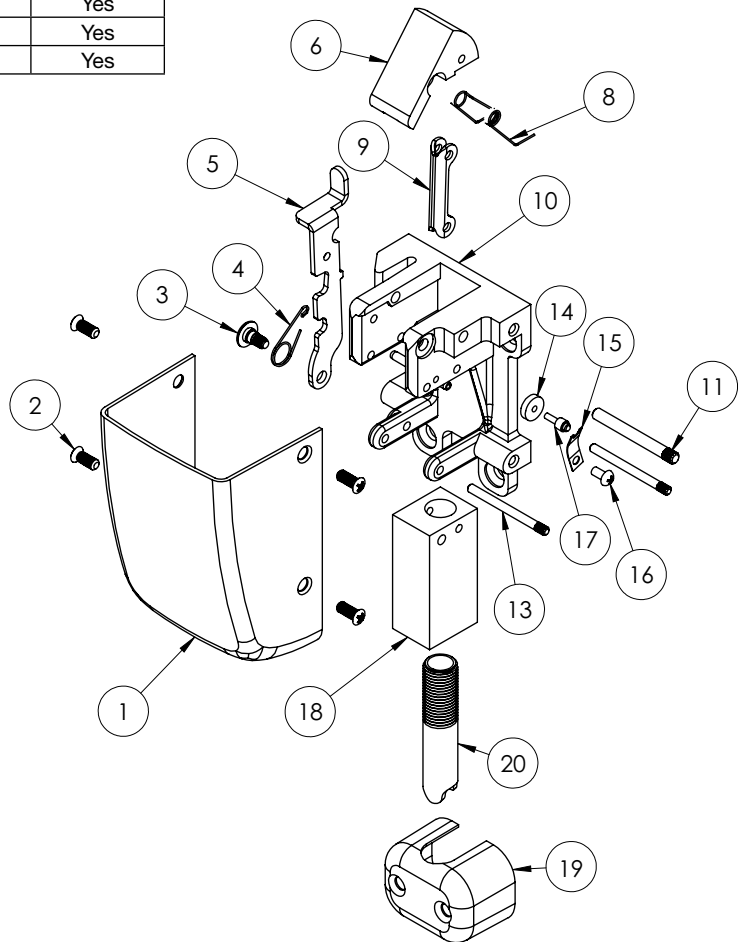

The warranty on SARGENT® products becomes void if the product is modified in any way, regardless of whether the modification causes or contributes to any alleged defect. If a SARGENT product is modified it may no longer meet industry certification and quality control standards applicable to the original product and is no longer a genuine SARGENT product.

Copyright ©2017 Sargent Manufacturing Company, an ASSA ABLOY Group company. All rights reserved. Reproduction in whole or in part without the express written permission of Sargent Manufacturing Company is prohibited.