

80 Series Parts Manual



For assistance, contact SARGENT at
800-727-5477 or www.sargentlock.com

Experience a safer
and more open world

Copyright © 2017-2021, SARGENT Manufacturing Company. All rights reserved. Reproduction in whole or in part without the express written permission of SARGENT Manufacturing Company is prohibited.

 **WARNING**

This product can expose you to lead which is known to the state of California to cause cancer and birth defects or other reproductive harm. For more information go to www.P65warnings.ca.gov.

A82311L 04/21

80 Series Rail Assemblies

12-
12- 5CH-



Assembly No.	Description	Option	Sellable
68-2702	Wide Stile E Rail Assembly*	(12-) Fire Rated	Yes
68-2703	Wide Stile F Rail Assembly*		Yes
68-2704	Wide Stile G Rail Assembly*		Yes
68-2705	Wide Stile J Rail Assembly*		Yes
68-2724	Narrow Stile E Rail Assembly*		Yes
68-2725	Narrow Stile F Rail Assembly*		Yes
68-2726	Narrow Stile G Rail Assembly*		Yes
68-2727	Narrow Stile J Rail Assembly*		Yes

Assembly No.	Description	Option	Sellable
68-7524	Wide Stile E Rail Assembly*	(12-)(5CH-) Fire Rated	Yes
68-7525	Wide Stile F Rail Assembly*		Yes
68-7527	Wide Stile G Rail Assembly*		Yes
68-7526	Wide Stile J Rail Assembly*		Yes
68-8021	Narrow Stile E Rail Assembly*		Yes
68-8117	Narrow Stile F Rail Assembly*		Yes
68-8309	Narrow Stile G Rail Assembly*		Yes
68-8213	Narrow Stile J Rail Assembly*		Yes

Item	Assy No.	Part No.	Description	Qty	Sellable
1	See Chart Above	68-0550	Mounting Rail Insert Wide(E)*	1	Yes
		68-0549	Mounting Rail Insert Wide(F)*		Yes
		68-0554	Mounting Rail Insert Wide(J)*		Yes
		68-0551	Mounting Rail Insert Wide(G)*		Yes
		68-1375	Mounting Rail Insert Narrow(E, F)*		Yes
		68-0553	Mounting Rail Insert Narrow(J)*		Yes
		68-0552	Mounting Rail Insert Narrow(G)*		Yes
2		68-0950	Mounting Rail Wide(E)*	1	Yes
		68-0952	Mounting Rail Wide(F)*		Yes
		68-0948	Mounting Rail Wide(J)*		Yes
		68-0949	Mounting Rail Wide(G)*		Yes
		68-0958	Mounting Rail Narrow(E)*		Yes
		68-0955	Mounting Rail Narrow(F)*		Yes
		68-0956	Mounting Rail Narrow(J)*		Yes
68-0957	Mounting Rail Narrow(G)*	Yes			
3		01-1236	#6-32x 3/8" PH FL U'Cut	4	Yes
4		68-0943	Bracket	2	Yes
5		68-0945	Pivot Pin	2	Yes
6		01-0098	Retainer Ring	2	Yes
7		68-0229	Pivot Pin, Push Rail*	2	Yes
8		68-0236	Spring, Rail Arm	2	Yes
		68-1832	Spring, Rail Arm (5CH-)	2	Yes
9		68-3609	Connecting Arm Assembly	2	Yes
10		68-0615	Push Rail (E)*	1	Yes
		68-0618	Push Rail (F)*		Yes
		68-0616	Push Rail (J)*		Yes
		68-0617	Push Rail (G)*		Yes
11		809	TouchPad Assembly	1	Yes
12		01-4537	Standard Hole Plug	1	Yes

A8231.L 04/21

*Specify Finish

The warranty on SARGENT® products becomes void if the product is modified in any way, regardless of whether the modification causes or contributes to any alleged defect. If a SARGENT product is modified it may no longer meet industry certification and quality control standards applicable to the original product and is no longer a genuine SARGENT product.

84

Copyright © 2017-2021, SARGENT Manufacturing Company. All rights reserved. Reproduction in whole or in part without the express written permission of SARGENT Manufacturing Company is prohibited.

Experience a safer
and more open world

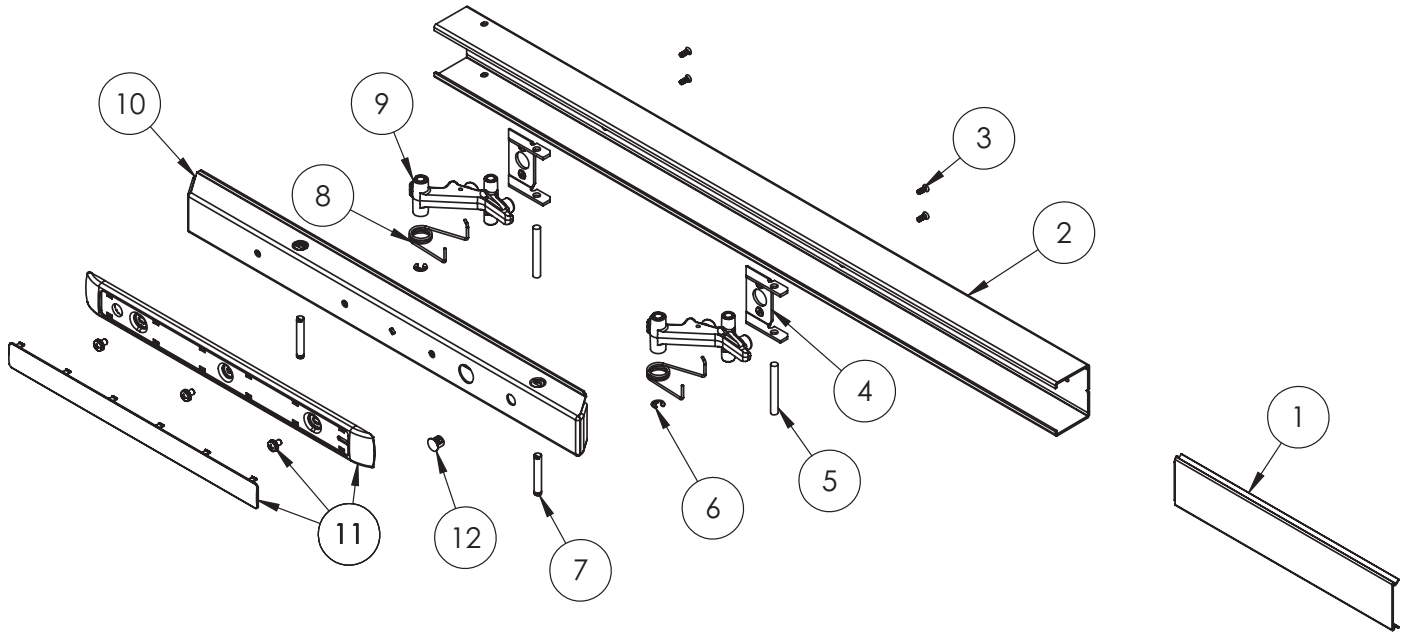

Assembly 68-2703 Shown Above

80 Series Rail Assemblies

12-56-

56-

12-56-5CH-

56-5CH-

SARGENT®

ASSA ABLOY

Assembly No.	Description	Option	Sellable
68-5542	Wide Stile E Rail Assembly*	(12-56-) (56-)	Yes
68-3212	Wide Stile F Rail Assembly*		Yes
68-3211	Wide Stile G Rail Assembly*		Yes
68-3213	Wide Stile J Rail Assembly*		Yes
68-5578	Narrow Stile E Rail Assembly*		Yes
68-3217	Narrow Stile F Rail Assembly*		Yes
68-3216	Narrow Stile G Rail Assembly*		Yes
68-3218	Narrow Stile J Rail Assembly*		Yes

Assembly No.	Description	Option	Sellable
68-8326	Wide Stile F Rail Assembly*	(12-56-)(5CH) (56-)(5CH)	Yes
68-8325	Wide Stile G Rail Assembly*		Yes
68-8327	Wide Stile J Rail Assembly*		Yes
68-8329	Narrow Stile F Rail Assembly*		Yes
68-8328	Narrow Stile G Rail Assembly*		Yes
68-8330	Narrow Stile J Rail Assembly*		Yes

Item	Assy No.	Part No.	Description	Qty	Sellable
1	See Chart Above	68-0550	Mounting Rail Insert Wide(E)*	1	Yes
		68-0549	Mounting Rail Insert Wide(F)*		Yes
		68-0554	Mounting Rail Insert Wide(J)*		Yes
		68-0551	Mounting Rail Insert Wide(G)*		Yes
		68-1375	Mounting Rail Insert Narrow(E, F)*		Yes
		68-0553	Mounting Rail Insert Narrow(J)*		Yes
2		68-0552	Mounting Rail Insert Narrow(G)*	1	Yes
		68-0950	Mounting Rail Wide(E)*		Yes
		68-0952	Mounting Rail Wide(F)*		Yes
		68-0948	Mounting Rail Wide(J)*		Yes
		68-0949	Mounting Rail Wide(G)*		Yes
		68-0958	Mounting Rail Narrow(E)*		Yes
3		68-0955	Mounting Rail Narrow(F)*	1	Yes
	68-0956	Mounting Rail Narrow(J)*	Yes		
	68-0957	Mounting Rail Narrow(G)*	Yes		
	M56AE	Rail Motor Kit, E	1		Yes
	(Std) M56AF	Rail Motor Kit, F ¹			Yes
(5CH) M56AF	Yes				
(Std) M56AJ	Rail Motor Kit, J ¹	Yes			
(5CH) M56AJ		Yes			
4	(Std) M56AG	Rail Motor Kit, G ¹	1	Yes	
	(5CH) M56AG			Yes	
5	68-0229	Pivot Pin, Push Rail*	2	Yes	
6	68-0236	Spring, Rail Arm	2	Yes	
7	01-0098	Retaining Ring	2	Yes	
8	809	TouchPad Assembly	1	Yes	
	68-0615	Standard Push Rail, E*	1	Yes	
	68-0618	Standard Push Rail, F*		Yes	
	68-0616	Standard Push Rail, J*		Yes	
	68-0617	Standard Push Rail, G*		Yes	
9	68-3609	Connecting Arm Assembly	1	Yes	
10	52-1261	56- Input Harness Assembly	2	Yes	
11	01-1236	#6-32x3/8" PH FL U' CUT	4	Yes	
12	68-0945	Pivot Pin	1	Yes	
13	68-0943	Bracket	1	Yes	

All Related HK- Assemblies Listed Below

Option Code	E Wide	F Wide	J Wide	G Wide	E Narrow	F Narrow	J Narrow	G Narrow	Sellable
19-56-HK-*	68-5515	68-5516	68-5517	68-5518	68-5602	68-5603	68-5604	68-5605	Yes
53-56-HK-*	68-5554*	68-5555*	68-5556*	68-5557*	68-5594*	68-5595*	68-5596*	68-5597*	Yes
53-55-56-HK-*	68-5558*	68-5559	68-5560	68-5561*	68-5598*	68-5599*	68-5600*	68-5601*	Yes
19-53-56-HK-*	68-5519*	68-5520*	68-5521*	68-5522*	68-5610*	68-5611*	68-5612*	68-5613*	Yes
19-53-55-56-HK-*	68-5538*	68-5539*	68-5540*	68-5541*	68-5614*	68-5615*	68-5616*	68-5617*	Yes
5CH-19-56-HK-*	N/A	68-8358	68-8359	68-8360	N/A	68-8361	68-8359	68-8363	Yes
5CH-53-56-HK-*	N/A	68-8475	68-8476	68-8477	N/A	68-8481	68-8476	68-8483	Yes
5CH-53-55-56-HK-*	N/A	68-8475	68-8476	68-8477	N/A	68-8481	68-8476	68-8483	Yes
5CH-19-53-56-HK-*	N/A	68-8514	68-8515	68-8516	N/A	68-8517	68-8515	68-8519	Yes
5CH-19-53-55-56-HK-*	N/A	68-8514	68-8515	68-8516	N/A	68-8517	68-8515	68-8519	Yes
5CH-56-HK*	N/A	68-8337	68-8332	68-8339	N/A	68-8331	68-8332	68-8333	Yes
5CH-55-56-19-HK*	N/A	68-8409	68-8404	68-8411	N/A	68-8403	68-8404	68-8405	Yes
5CH-55-56-HK*	N/A	68-8391	68-8386	68-8393	N/A	68-8385	68-8386	68-8387	Yes

Parts 3-13 Available as Assembly No. 52-3541 for E, 52-3542 for F, 52-3543 for J, 52-3544 for G

*Specify Finish

1. Specify Standard or 5CH prefix before order

The warranty on SARGENT® products becomes void if the product is modified in any way, regardless of whether the modification causes or contributes to any alleged defect. If a SARGENT product is modified it may no longer meet industry certification and quality control standards applicable to the original product and is no longer a genuine SARGENT product.

86

Copyright © 2017-2021, SARGENT Manufacturing Company. All rights reserved. Reproduction in whole or in part without the express written permission of SARGENT Manufacturing Company is prohibited.

Experience a safer
and more open world

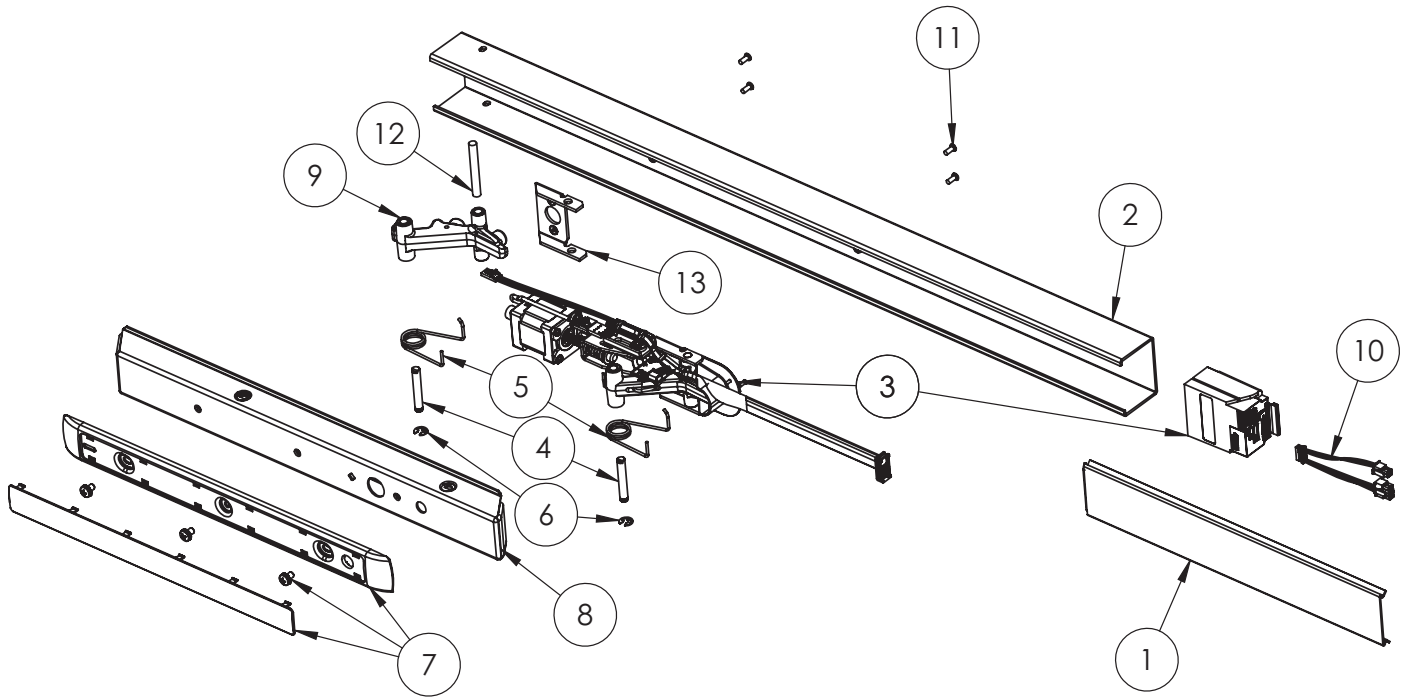

Assembly 68-5578 Shown Above

80 Series Rail Assemblies

12-59-

59-

SARGENT®

ASSA ABLOY

Assembly No.	Description	Option	Sellable
68-6098	Wide Stile E Rail Assembly*	(59-)	Yes
68-3780	Wide Stile F Rail Assembly*		Yes
68-3781	Wide Stile G Rail Assembly*		Yes
68-3782	Wide Stile J Rail Assembly*		Yes
68-6100	Narrow Stile E Rail Assembly*		Yes
68-3788	Narrow Stile F Rail Assembly*		Yes
68-3789	Narrow Stile G Rail Assembly*		Yes
68-3790	Narrow Stile J Rail Assembly*		Yes
68-6099	Wide Stile E Rail Assembly*	(12-59-)	Yes
68-3784	Wide Stile F Rail Assembly*		Yes
68-3785	Wide Stile J Rail Assembly*		Yes
68-3786	Wide Stile G Rail Assembly*		Yes
68-6101	Narrow Stile E Rail Assembly*		Yes
68-3792	Narrow Stile F Rail Assembly*		Yes
68-3793	Narrow Stile G Rail Assembly*		Yes
68-3794	Narrow Stile J Rail Assembly*		Yes

Item	Assy No.	Part No.	Description	Qty	Sellable
1	See Chart Above	809	TouchPad Assembly	1	Yes
2		68-1027	Push Rail, E*	1	No
		68-1030	Push Rail, F*		Yes
		68-1028	Push Rail, G*		Yes
		68-1029	Push Rail, J*		Yes
3		68-0582	Lockdown Cam ¹	1	Yes
4		01-4537	Standard Hole Plug	1	Yes
5		01-0098	Retaining Ring	2	Yes
6		68-0229	Pivot Pin, Push Rail*	2	Yes
7		68-1049	Rubber Cushion	1	No
8		68-1039	Support Plate	1	No
9		52-1701	59- Wire Guide	1	Yes
10		68-0236	Spring, Rail Arm	2	Yes
11		68-0945	Pivot Pin	2	Yes
12		01-0711	Flanged Nyliner	8	Yes
13		52-4765	59- Connecting Arm	1	No
14		68-0943	Bracket	1	Yes
15		52-0935	Wire Barrier	1	Yes
16		52-4733	59- Harness Sub-Plate Assembly	1	No
		52-4734	59- Harness Sub-Plate Assembly		No
17		01-0610	Wave Spring Washer ¹	1	Yes
18	68-0583	Lockdown Button ₁	1	Yes	
19	01-4466	Machine Screw SEMS ¹	1	No	
20	01-1236	#6-32X3/8" PH FL U'Cut 6**		Yes	
21	68-6127	Connecting Arm	1	Yes	

Item	Assy No.	Part No.	Description	Qty	Sellable			
22	See Chart Above	68-1045	Mounting Rail, E Narrow*	1	Yes			
		68-1042	Mounting Rail, F Narrow*		Yes			
		68-1043	Mounting Rail, J Narrow*		Yes			
		68-1044	Mounting Rail, G Narrow*		Yes			
		68-0950	Mounting Rail, E Wide*		Yes			
		68-1058	Mounting Rail, F Wide*		Yes			
		68-1059	Mounting Rail, J Wide*		Yes			
		68-1060	Mounting Rail, G Wide*		Yes			
		23	See Chart Above		68-6090	Insert Assembly, E Wide	1	No
					68-6091	Insert Assembly, F Wide		No
68-6092	Insert Assembly, J Wide			No				
68-6093	Insert Assembly, G Wide			No				
68-6097	Insert Assembly, E Narrow			No				
68-6094	Insert Assembly, F Narrow			No				
68-6095	Insert Assembly, J Narrow			No				
68-6096	Insert Assembly, G Narrow			No				
24	See Chart Above	52-1292	Harness Assembly	1	Yes			
		52-1293	Harness Assembly		Yes			

A8231.L 04/21

*Specify Finish

**Qty is 6 in Sizes F J G, 4 in Size E

1. Do not use on any 12- Rail Assembly

The warranty on SARGENT® products becomes void if the product is modified in any way, regardless of whether the modification causes or contributes to any alleged defect. If a SARGENT product is modified it may no longer meet industry certification and quality control standards applicable to the original product and is no longer a genuine SARGENT product.

88

Copyright © 2017-2021, SARGENT Manufacturing Company. All rights reserved. Reproduction in whole or in part without the express written permission of SARGENT Manufacturing Company is prohibited.

Experience a safer
and more open world

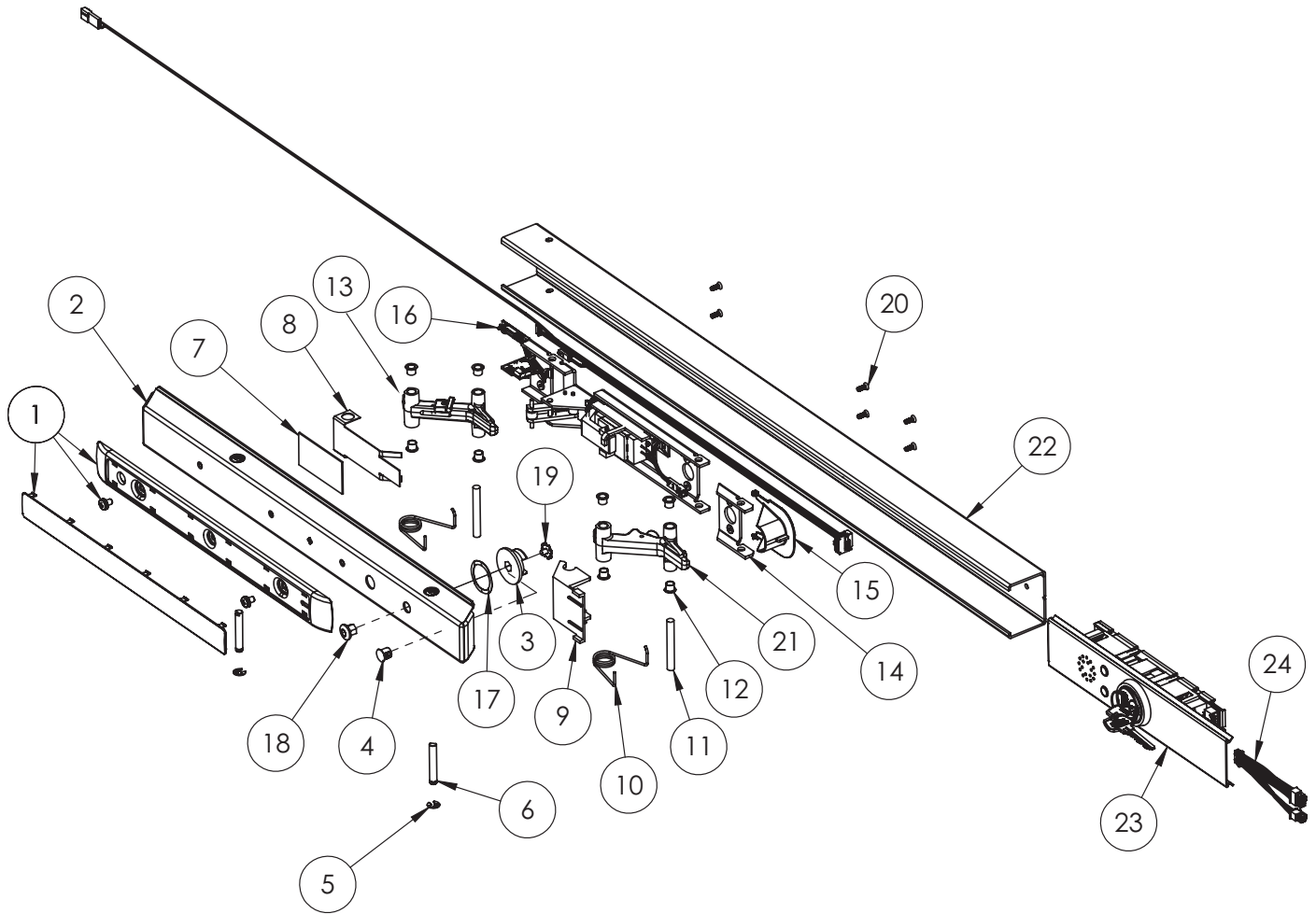

Assembly 68-3780 Shown Above

**80 Series Rail Assemblies
Standard-Non-Fire Rated**



Assembly No.	Description	Option	Sellable
68-2694	Wide Stile E Rail Assembly*	Standard Rails	Yes
68-2695	Wide Stile F Rail Assembly*		Yes
68-2696	Wide Stile G Rail Assembly*		Yes
68-2697	Wide Stile J Rail Assembly*		Yes
68-2716	Narrow Stile E Rail Assembly*		Yes
68-2717	Narrow Stile F Rail Assembly*		Yes
68-2718	Narrow Stile G Rail Assembly*		Yes
68-2719	Narrow Stile J Rail Assembly*		Yes
68-7520	Wide Stile E Rail Assembly*	Standard Rails (5CH-)	Yes
68-7521	Wide Stile F Rail Assembly*		Yes
68-7522	Wide Stile G Rail Assembly*		Yes
68-7523	Wide Stile J Rail Assembly*		Yes
68-8001	Narrow Stile E Rail Assembly*		Yes
68-8097	Narrow Stile F Rail Assembly*		Yes
68-8289	Narrow Stile G Rail Assembly*		Yes
68-8193	Narrow Stile J Rail Assembly*		Yes

Item	Assy No.	Part No.	Description	Qty	Sellable
1	See Table Above	68-0550	Mounting Rail Insert Wide(E)*	1	Yes
		68-0549	Mounting Rail Insert Wide(F)*		Yes
		68-0554	Mounting Rail Insert Wide(J)*		Yes
		68-0551	Mounting Rail Insert Wide(G)*		Yes
		68-1375	Mounting Rail Insert Narrow(E, F)*		Yes
		68-0553	Mounting Rail Insert Narrow(I)*		Yes
		68-0552	Mounting Rail Insert Narrow(G)*		Yes
2		01-1236	#6-32x3/8 PH FL U'Cut	4	Yes
3		68-0950	Mounting Rail, E Wide*	1	Yes
		68-0952	Mounting Rail, F Wide*		Yes
		68-0948	Mounting Rail, J Wide*		Yes
		68-0949	Mounting Rail, G Wide*		Yes
		68-0958	Mounting Rail, E Narrow*		Yes
		68-0955	Mounting Rail, F Narrow*		Yes
	68-0956	Mounting Rail, J Narrow*	Yes		
4	68-0957	Mounting Rail, G Narrow*	Yes		
5	68-0943	Bracket	2	Yes	
6	68-3609	Connecting Arm Assembly	2	Yes	
7	01-4466	Machine Screw SEMS ¹	1	Yes	
8	68-0582	Lockdown Cam ¹	1	Yes	
9	01-0610	Wave Spring Washer ¹	1	Yes	
9	68-0236	Spring, Rail Arm	2	Yes	
	68-1832	Spring, Rail Arm (5CH-)	2	Yes	
10	68-0945	Pivot Pin	2	Yes	
11	01-0098	Retaining Ring	2	Yes	
12	68-0229	Pivot Pin Push Rail*	2	Yes	
13	68-0583	Lockdown Button ¹	1	Yes	
14	809	Touch Pad Assembly	1	Yes	
15	68-0615	Push Rail, E*	1	Yes	
	68-0618	Push Rail, F*		Yes	
	68-0616	Push Rail, J*		Yes	
	68-0617	Push Rail, G*		Yes	

*Specify Finish
1. Do not use on any 12- Rail Assembly

The warranty on SARGENT® products becomes void if the product is modified in any way, regardless of whether the modification causes or contributes to any alleged defect. If a SARGENT product is modified it may no longer meet industry certification and quality control standards applicable to the original product and is no longer a genuine SARGENT product.

Copyright © 2017-2021, SARGENT Manufacturing Company. All rights reserved. Reproduction in whole or in part without the express written permission of SARGENT Manufacturing Company is prohibited.

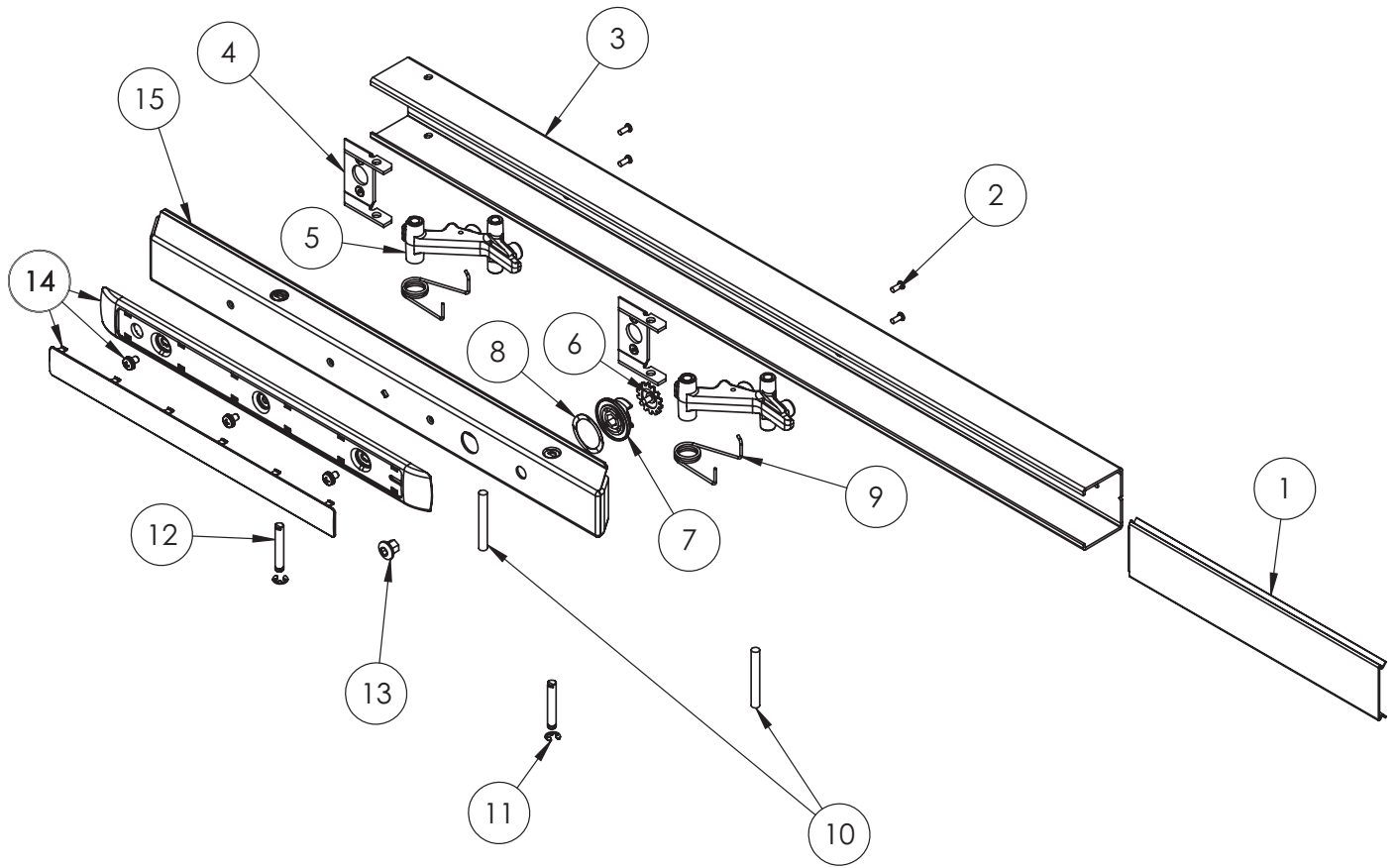

Assembly 68-2695 Shown Above

80 Series Rail Assemblies

16-
16-5CH-



Assembly No.	Description	Option	Sellable
68-2698	Wide Stile E Rail Assembly*	16-	Yes
68-2699	Wide Stile F Rail Assembly*		Yes
68-2700	Wide Stile G Rail Assembly*		Yes
68-2701	Wide Stile J Rail Assembly*		Yes
68-2720	Narrow Stile E Rail Assembly*		Yes
68-2721	Narrow Stile F Rail Assembly*		Yes
68-2722	Narrow Stile G Rail Assembly*		Yes
68-2723	Narrow Stile J Rail Assembly*		Yes
68-7528	Wide Stile E Rail Assembly*	16-5CH-	Yes
68-7529	Wide Stile F Rail Assembly*		Yes
68-7530	Wide Stile G Rail Assembly*		Yes
68-7531	Wide Stile J Rail Assembly*		Yes
68-8007	Narrow Stile E Rail Assembly*		Yes
68-8103	Narrow Stile F Rail Assembly*		Yes
68-8295	Narrow Stile G Rail Assembly*		Yes
68-8199	Narrow Stile J Rail Assembly*		Yes

Item	Assy No.	Part No.	Description	Qty	Sellable
1	See Table Above	809	Touch Pad Assembly	1	Yes
2		68-0615	Push Rail, E*	1	Yes
		68-0618	Push Rail, F*		Yes
		68-0616	Push Rail, J*		Yes
		68-0617	Push Rail, G*		Yes
3		68-0943	Bracket	2	Yes
4		01-1236	CR-FHMS 6-32X3/8"	4	Yes
5		68-0950	Mounting Rail, E Wide*	1	Yes
		68-0952	Mounting Rail, F Wide*		Yes
		68-0948	Mounting Rail, J Wide*		Yes
		68-0949	Mounting Rail, G Wide*		Yes
		68-0958	Mounting Rail, E Narrow*		Yes
		68-0955	Mounting Rail, F Narrow*		Yes
		68-0956	Mounting Rail, J Narrow*		Yes
6		68-0957	Mounting Rail, G Narrow*	1	Yes
		816-5	Insert Assembly, E Wide ¹ *		Yes
		816-1	Insert Assembly, F Wide ¹ *		Yes
		816-7	Insert Assembly, J Wide ¹ *		Yes
		816-4	Insert Assembly, G Wide ¹ *		Yes
		816-2	Insert Assembly, E/F Narrow ¹ *		Yes
7		816-6	Insert Assembly, J Narrow ¹ *	1	Yes
		816-3	Insert Assembly, G Narrow ¹ *		Yes
		68-0945	Pivot Pin		2
8		01-0098	Retaining Ring	2	Yes
9	68-0229	Pivot Pin, Push Rail*	2	Yes	
10	68-0236	Spring, Rail Arm	2	Yes	
	68-1832	Spring, Rail Arm (5CH-)	2	Yes	
11	68-3609	Connecting Arm Assembly	2	Yes	
12	01-4537	Standard Hole Plug	1	Yes	

*Specify Finish
1. Do not use on any 12- Rail Assembly

The warranty on SARGENT® products becomes void if the product is modified in any way, regardless of whether the modification causes or contributes to any alleged defect. If a SARGENT product is modified it may no longer meet industry certification and quality control standards applicable to the original product and is no longer a genuine SARGENT product.

Copyright © 2017-2021, SARGENT Manufacturing Company. All rights reserved. Reproduction in whole or in part without the express written permission of SARGENT Manufacturing Company is prohibited.

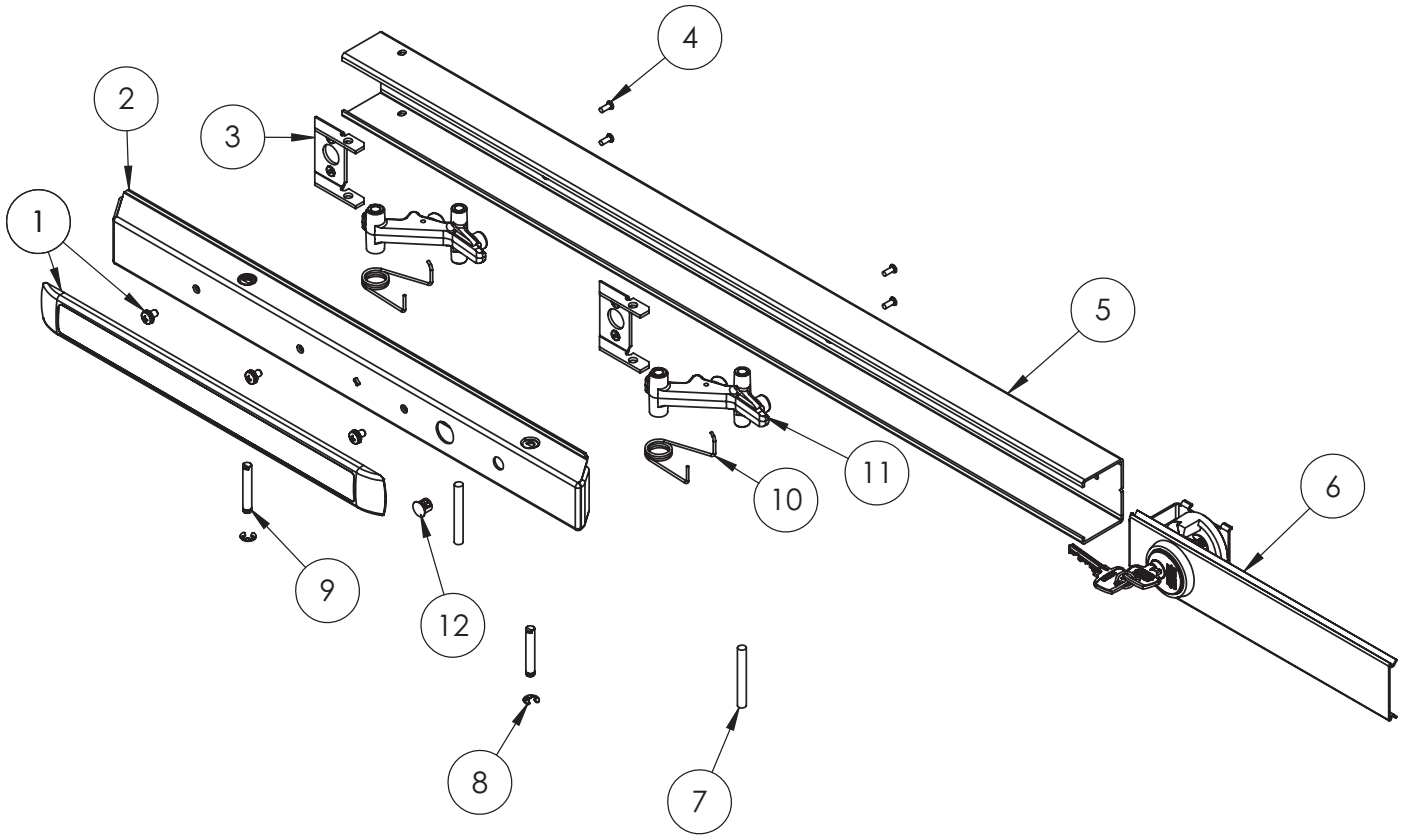

Assembly 68-2699 Shown Above

80 Series Rail Assemblies
12-19-
19-
12-19-5CH
19-5CH-



Assembly No.	Description	Option	Sellable
68-2918	E Wide Rail Assembly*	19-	Yes
68-2919	F Wide Rail Assembly*		Yes
68-2921	J Wide Rail Assembly*		Yes
68-2920	G Wide Rail Assembly*		Yes
68-2905	E Narrow Rail Assembly*		Yes
68-2906	F Narrow Rail Assembly*		Yes
68-2908	J Narrow Rail Assembly*		Yes
68-2907	G Narrow Rail Assembly*		Yes
68-2926	E Wide Rail Assembly*	12-19-	Yes
68-2927	F Wide Rail Assembly*		Yes
68-2929	J Wide Rail Assembly*		Yes
68-2928	G Wide Rail Assembly*		Yes
68-2913	E Narrow Rail Assembly*		Yes
68-2914	F Narrow Rail Assembly*		Yes
68-2916	J Narrow Rail Assembly*		Yes
68-2915	G Narrow Rail Assembly*		Yes

Assembly No.	Description	Option	Sellable
68-7540	E Wide Rail Assembly*	19-5CH-	Yes
68-7541	F Wide Rail Assembly*		Yes
68-7543	J Wide Rail Assembly*		Yes
68-7542	G Wide Rail Assembly*		Yes
68-8011	E Narrow Rail Assembly*		Yes
68-8107	F Narrow Rail Assembly*		Yes
68-8203	J Narrow Rail Assembly*		Yes
68-8299	G Narrow Rail Assembly*		Yes
68-7536	E Wide Rail Assembly*	12-19-5CH-	Yes
68-7537	F Wide Rail Assembly*		Yes
68-7538	J Wide Rail Assembly*		Yes
68-7539	G Wide Rail Assembly*		Yes
68-8027	E Narrow Rail Assembly*		Yes
68-8123	F Narrow Rail Assembly*		Yes
68-8219	J Narrow Rail Assembly*		Yes
68-8315	G Narrow Rail Assembly*		Yes

Item	Assy No.	Part No.	Description	Qty	Sellable
1	See Table Above	68-0583	Lockdown Button ¹	1	Yes
2		68-0736	Push Rail, E*	1	Yes
		68-0739	Push Rail, F*		Yes
		68-0737	Push Rail, J*		Yes
		68-0738	Push Rail, G*		Yes
3		01-0610	Wave Spring Washer ¹	1	Yes
4		68-0582	Lockdown Cam ¹	1	Yes
5		01-4466	SEMS Machine Screw ¹	1	Yes
6		68-0236	Spring, Rail Arm	2	Yes
		68-1832	Spring, Rail Arm (5CH-)	2	Yes
7		01-0098	Retaining Ring	2	Yes
8		68-0229	Pivot Pin, Push Rail	2	Yes
9		68-0945	Pivot Pin, Mounting Rail	2	Yes
10		68-0943	Bracket	2	Yes
11	68-0950	Mounting Rail, E*	1	Yes	
	68-0952	Mounting Rail, F*		Yes	
	68-0949	Mounting Rail, J*		Yes	
	68-0948	Mounting Rail, G*		Yes	
12	01-1236	#6-32X3/8" Machine Screw ¹	4	Yes	
13	68-0550	Mounting Rail Insert, E*	1	Yes	
	68-0549	Mounting Rail Insert, F*		Yes	
	68-0552	Mounting Rail Insert, J*		Yes	
	68-0551	Mounting Rail Insert, G*		Yes	
14	01-4537	Standard Hole Plug	1	Yes	

*Specify Finish
 1. Do not use on any 12- Rail Assembly

A8231.L 04/21

The warranty on SARGENT® products becomes void if the product is modified in any way, regardless of whether the modification causes or contributes to any alleged defect. If a SARGENT product is modified it may no longer meet industry certification and quality control standards applicable to the original product and is no longer a genuine SARGENT product.

80 Series Rail Assemblies
 12-19-
 19-
 12-19-5CH
 19-5CH-

SARGENT
ASSA ABLOY

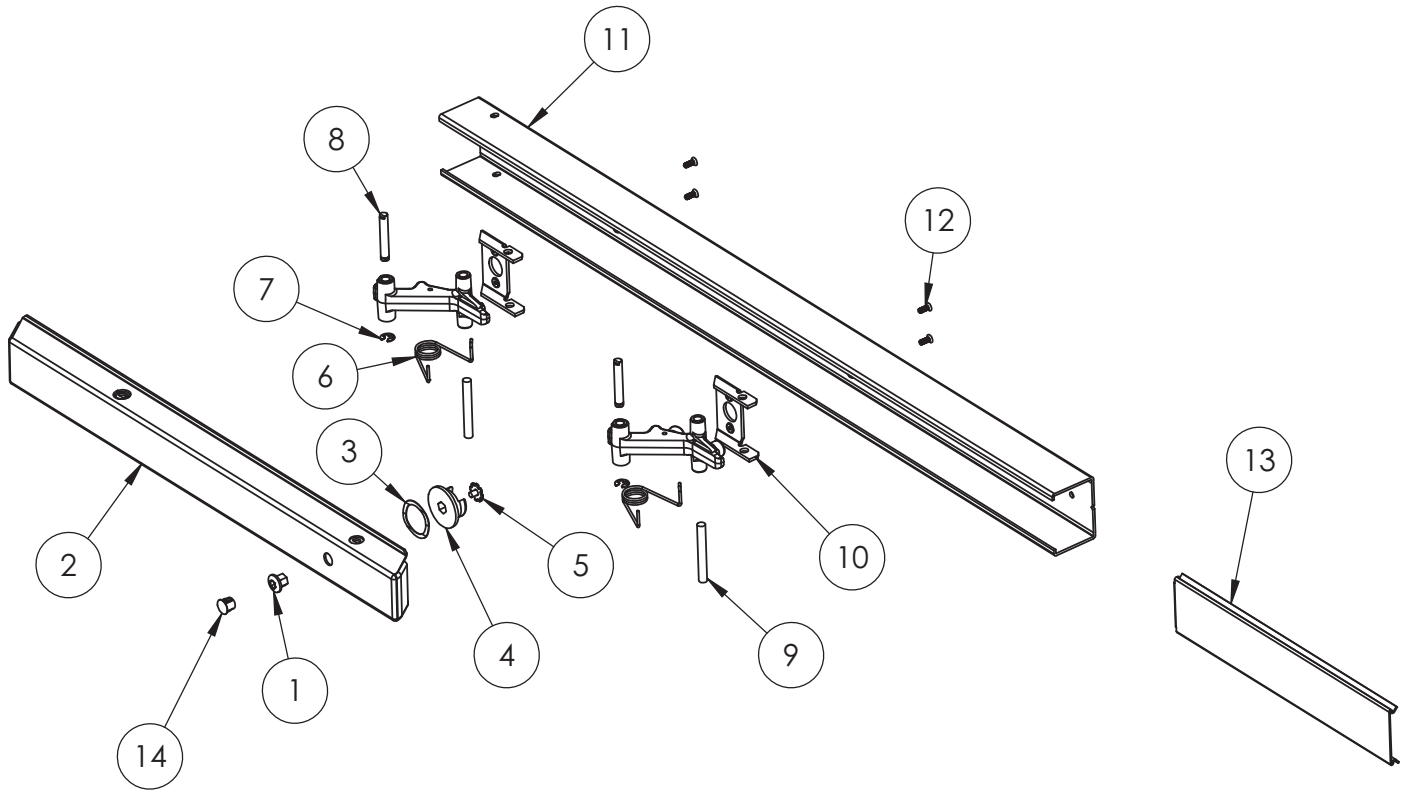

Assembly 68-2919 Shown Above

Experience a safer
 and more open world

The warranty on SARGENT® products becomes void if the product is modified in any way, regardless of whether the modification causes or contributes to any alleged defect. If a SARGENT product is modified it may no longer meet industry certification and quality control standards applicable to the original product and is no longer a genuine SARGENT product.

Copyright © 2017-2021, SARGENT Manufacturing Company. All rights reserved. Reproduction in whole or in part without the express written permission of SARGENT Manufacturing Company is prohibited.

5300 Series Parts Manual

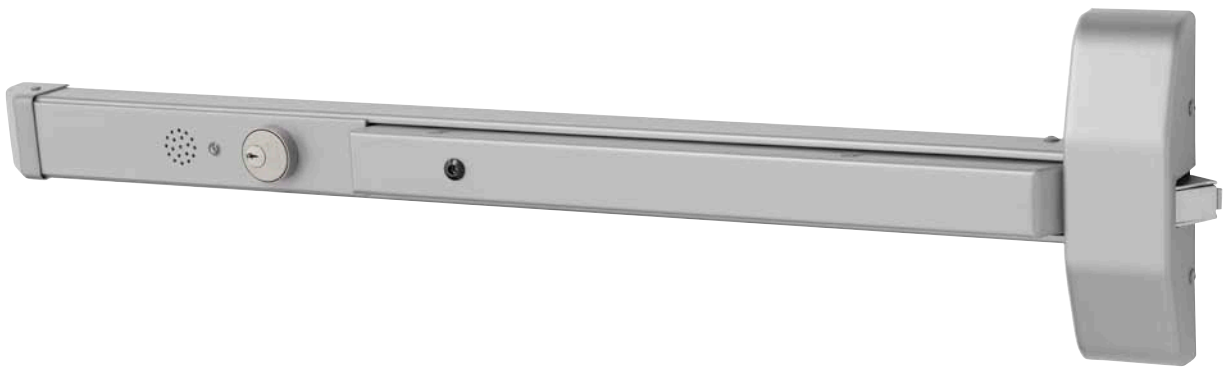

For assistance, contact SARGENT at
800-727-5477 or www.sargentlock.com

Experience a safer
and more open world

 **WARNING**

This product can expose you to lead which is known to the state of California to cause cancer and birth defects or other reproductive harm. For more information go to www.P65warnings.ca.gov.

A8266-A 11/19

Item	Part No.	Description	Qty	Sellable
1	68-0736	Push Rails: E ^{1,2}	1	
	68-0739	Push Rails: F ^{1,2}	1	
	68-0737	Push Rails: J ^{1,2}	1	
	68-0738	Push Rails: G ^{1,2}	1	
2	68-0950	Mounting Rail: E ^{1,2}	1	
	68-0952	Mounting Rail: F ^{1,2}	1	
	68-0948	Mounting Rail: J ^{1,2}	1	
	68-0949	Mounting Rail: G ^{1,2}	1	
3	52-5804	Insert Assembly: E ^{1,2}	1	
	52-2678	Insert Assembly: F ^{1,2}	1	
	52-2683	Insert Assembly: J ^{1,2}	1	
	52-2680	Insert Assembly: G ^{1,2}	1	
4	68-3609	Connecting Arm Assembly	2	
5	01-1236	CR-FHMS 6-32x0.375 ¹	4	
6	68-0236	Spring, Rail Arm	2	
7	68-0229	Pivot Pin (Push Rail)	2	
8	01-0098	Retaining Ring	2	
9	01-4537	Standard Hole Plug	1	
10	68-0943	Bracket	2	
11	68-0945	Pivot Pin Exit Device	2	

Notes:

- 1. Specify finish
- 2. Specify door width

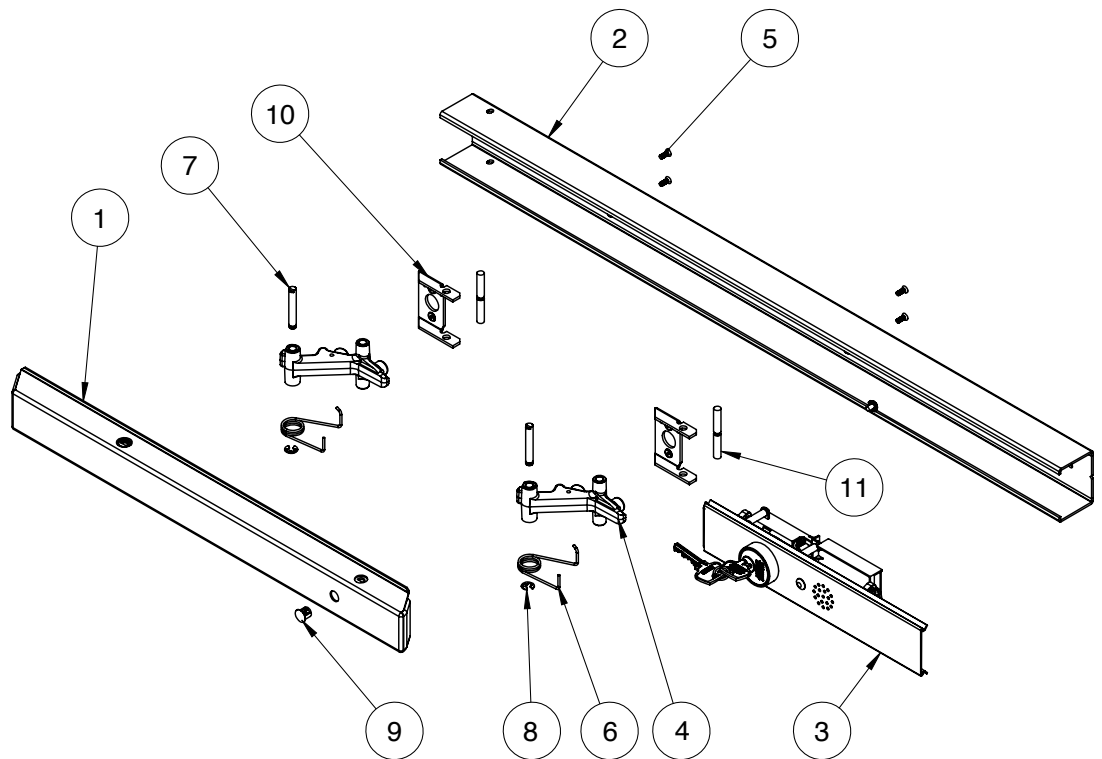

The warranty on SARGENT® products becomes void if the product is modified in any way, regardless of whether the modification causes or contributes to any alleged defect. If a SARGENT product is modified it may no longer meet industry certification and quality control standards applicable to the original product and is no longer a genuine SARGENT product.

Copyright© 2019, ASSA ABLOY Access and Egress Hardware Group, Inc. All rights reserved. Reproduction in whole or in part without the express written permission of ASSA ABLOY Access and Egress Hardware Group, Inc. is prohibited.

Item	Part No.	Description	Qty	Sellable
1	68-0736	Push Rails: E ^{1,2}	1	
	68-0739	Push Rails: F ^{1,2}	1	
	68-0737	Push Rails: J ^{1,2}	1	
	68-0738	Push Rails: G ^{1,2}	1	
2	68-0950	Mounting Rail: E ^{1,2}	1	
	68-0952	Mounting Rail: F ^{1,2}	1	
	68-0948	Mounting Rail: J ^{1,2}	1	
	68-0949	Mounting Rail: G ^{1,2}	1	
3	52-5804	Insert Assembly: E ^{1,2}	1	
	52-2678	Insert Assembly: F ^{1,2}	1	
	52-2683	Insert Assembly: J ^{1,2}	1	
	52-2680	Insert Assembly: G ^{1,2}	1	
4	68-3609	Connecting Arm Assembly	2	
5	01-1236	CR-FHMS 6-32x0.375 ¹	4	
6	68-0236	Spring, Rail Arm	2	
7	68-0229	Pivot Pin (Push Rail)	2	
8	01-0098	Retaining Ring	2	
9	01-4466	Machine Screw SEMS	1	
10	68-0943	Bracket	2	
11	68-0582	Standard Dogging Cam (20 & 60)	1	
12	68-0583	Lockdown Button (20 & 80)	1	
13	01-0610	Wave Spring Washer	1	
14	68-0945	Pivot Pin Exit Device	2	

Notes:

1. Specify finish
2. Specify door width

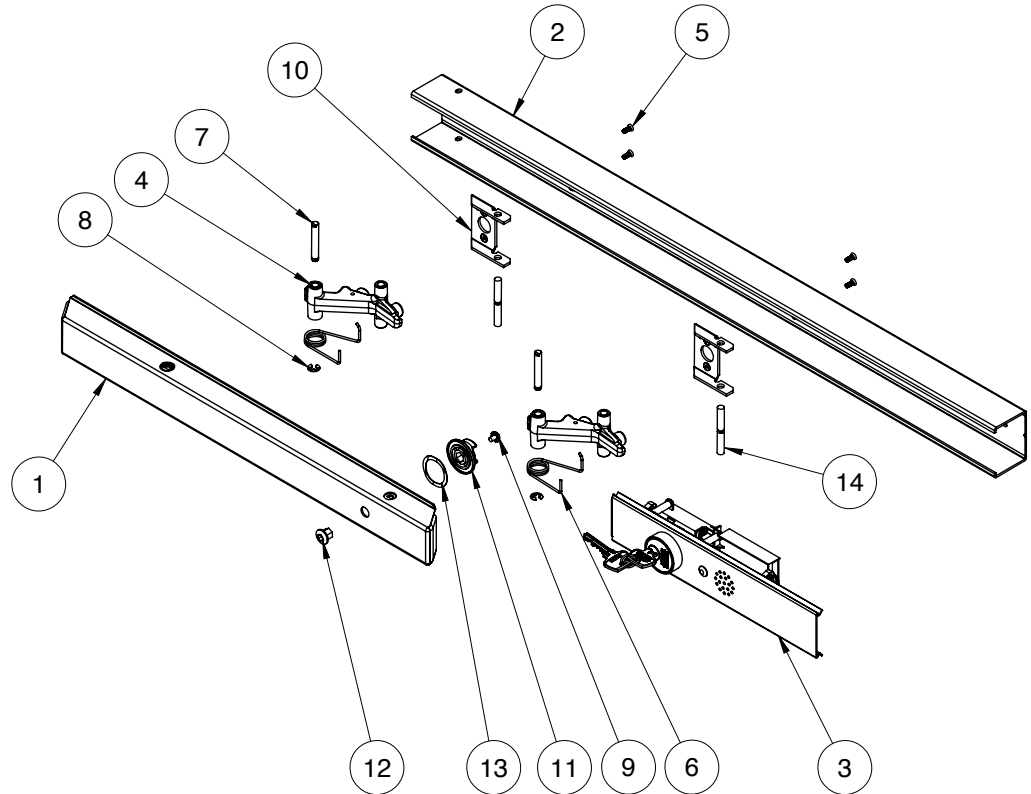

A8266:A 11/19

The warranty on SARGENT® products becomes void if the product is modified in any way, regardless of whether the modification causes or contributes to any alleged defect. If a SARGENT product is modified it may no longer meet industry certification and quality control standards applicable to the original product and is no longer a genuine SARGENT product.

Copyright© 2019, ASSA ABLOY Access and Egress Hardware Group, Inc. All rights reserved. Reproduction in whole or in part without the express written permission of ASSA ABLOY Access and Egress Hardware Group, Inc. is prohibited.