

80 Series Parts Manual



For assistance, contact SARGENT at
800-727-5477 or www.sargentlock.com

Experience a safer
and more open world

Copyright © 2017-2021, SARGENT Manufacturing Company. All rights reserved. Reproduction in whole or in part without the express written permission of SARGENT Manufacturing Company is prohibited.

 **WARNING**

This product can expose you to lead which is known to the state of California to cause cancer and birth defects or other reproductive harm. For more information go to www.P65warnings.ca.gov.

A82311L 04/21

Function	Assembly No.	Description	Sellable
8863	68-2109	LHRB	Yes
8863	68-2110	RHRB	Yes

Item	Assembly No.	Part No.	Description	Qty.	Sellable
1	See chart above	—	Chassis Assembly (LHRB)	1	No
		—	Chassis Assembly (RHRB)	1	No
2		68-0271	Pivot Pin Thumb Lever	1	Yes
3		68-0273	Bushing Thumb Lever	1	Yes
4		68-0260	Thumb Piece Lever LHRB	1	Yes
		68-0261	Thumb Piece Lever RHRB	1	No
5		97-0040	Bushing Latchbolt	1	Yes
6		98-0028	Spring Latchbolt	1	Yes
7		98-2034	Latchbolt Assy	1	Yes
8		01-0008	Groove Pin	1	No
9		01-0005	Retaining Ring	1	Yes
10		01-0013	Screw Latchbolt Pivot	1	Yes
11		01-4512	Pivot Pin Lift Arm	1	Yes
12	98-0018	Outside Cylinder Hub	1	Yes	
13	68-0241	Lift Arm	1	Yes	
14	N/A	68-0406	Cover ¹	1	No
15		68-3908	Cover Screw Pack ¹	1	Yes
Not Shown		68-2143	Screw Pack	1	Yes
		649	Strike Pack	1	Yes

1. Specify finish

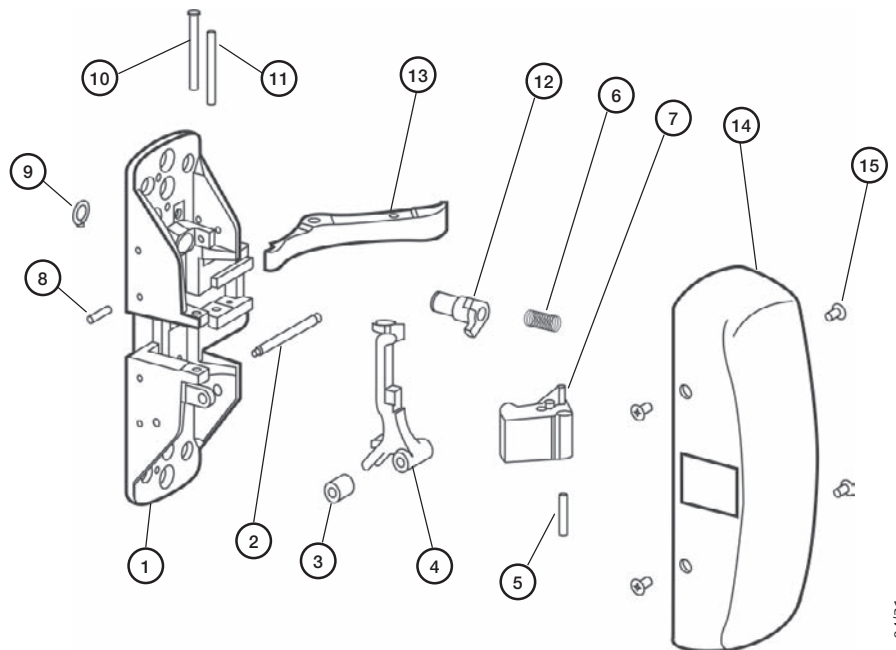

The warranty on SARGENT® products becomes void if the product is modified in any way, regardless of whether the modification causes or contributes to any alleged defect. If a SARGENT product is modified it may no longer meet industry certification and quality control standards applicable to the original product and is no longer a genuine SARGENT product.

Copyright © 2017-2021, SARGENT Manufacturing Company. All rights reserved. Reproduction in whole or in part without the express written permission of SARGENT Manufacturing Company is prohibited.