

1131 Series

Door Closers

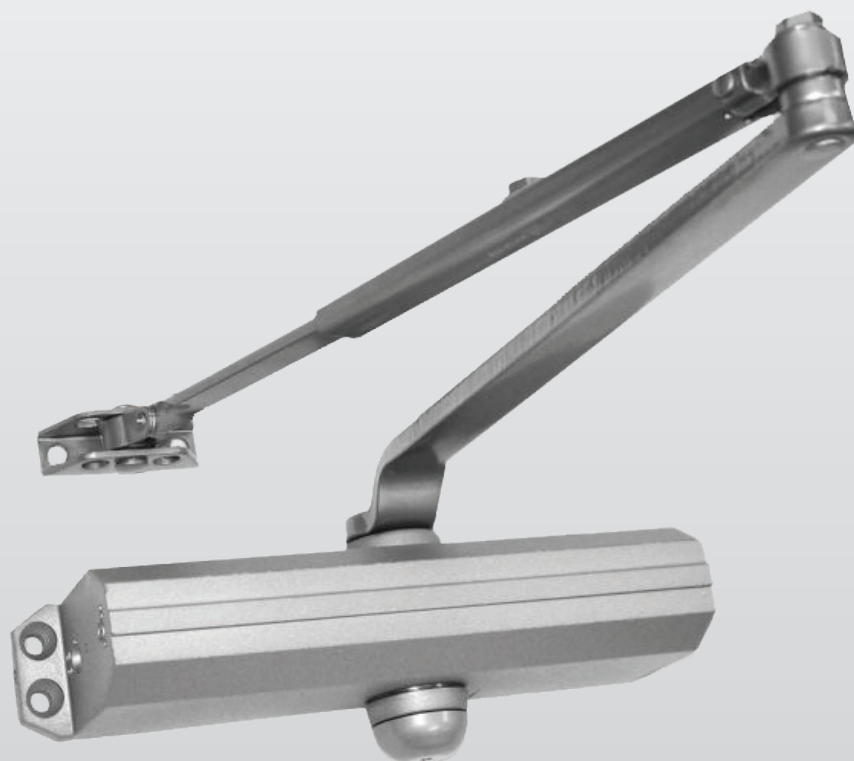

Table of Contents

1131 Series Door Closers

General Information.....	3
Applications	4
Applications & Accessories	5
Architectural Specifications	6
How To Order and Packaging	7

Any retrofit or other field modification to a fire rated opening can potentially impact the fire rating of the opening, and Sargent Manufacturing Company makes no representations or warranties concerning what such impact may be in any specific situation. When retrofitting any portion of an existing fire rated opening, or specifying and installing a new fire-rated opening, please consult with a code specialist or local code official (Authority Having Jurisdiction) to ensure compliance with all applicable codes and ratings.

On The Cover

- 1131 RU installed “Standard application”

General Information

1131 Series Door Closers

Features

- Reversible "Non-handed"
- Full rack and pinion
- High strength cast aluminum case
- Tri-packed for versatile mounting, inverted or parallel
- Arm leverage adjustment
- Heat treated high tensile springs
- One piece spindle heat treated for high strength
- Model available with spring adjustment
- Separate key controlled regulating valves for door closing and latching speed
- Two choices of finishes: EN for Aluminum Enamel, EB for Bronze Enamel to match 10B
- Valves are captivated to prohibit vandalism
- Adjustable backcheck valve is standard
- UL and ULC listed
- Typical uses hotel/motel guest rooms, assisted living centers, public housing, store fronts, office buildings
- Shall meet ANSI Grade 1 A156.4 requirements
- 25 year warranty
- Parallel Arm Conversion bracket included
- Mortise nuts and through bolts included
- Auxiliary door stop required
- Optional full cover available
- Wood and machine screws provided as standard

Non Hold Open "RU" Package



The RU package is provided with non hold open arm which includes additional bracket that allows installer the choice of standard, parallel or top jamb application. Used on Rated and Non Fire rated doors.

Standard application shown above.

Holder Arm "HU" Package

All applications for 1131 series closers shown in this catalog are also available with holder arms. Holding ranges are listed under the individual application. Specify "HU" arm when ordering.

The HU includes an extra bracket for field conversion from standard application to parallel arm application.

Series By Application

Description	Models
Adjustable from sizes 1 through 6: Door closers to meet handicapped requirements or for light through heavy weight interior doors	1131

Door Opening And Closing Cycle

The door opening cycle compresses the springs and positions the fluid to control the other cycles.

The backcheck cycle is controlled by the backcheck valve. This cycle slows the door before making contact with door stop. This can easily be turned off for doors that open more than 90°. (A door stop must be used to stop the door.)

Two separate valves control the door closing and latching speeds. The closing cycle controls the speed of door closing from the fully opened position to approximately five inches from the closed position. The latching cycle controls this last five inches.

1. Opening Cycle
2. Backcheck
3. Closing Speed
4. Latching Speed

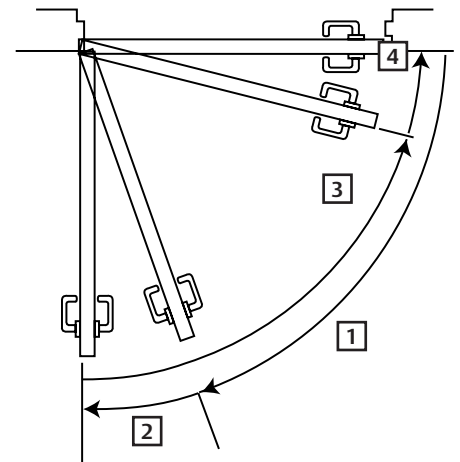

CAUTION: Door Closers for Low Opening Force Applications:

Door closers installed in openings required to meet the requirements of the Americans With Disabilities Act or ANSI/BHMA Standard A117.1, when adjusted to meet those requirements, may not provide adequate closing power to dependably close and latch the door based on opening or site conditions.

Applications

1131 Series Door Closers

SARGENT
ASSA ABLOY

Standard Application

Closer mounts on pull side of door. Two mounting positions allowing opening up to 180° if wall and frame conditions allow.

Standard Mounting: Standard mounting provides maximum power allowing door to open 100°. Holding range of holder arm (hold open arm): 85°-100°.

Alternate Mounting: Closer installed to allow for 180° opening. Range of hold open arm from 85-180°

Maximum door opening: 180° if wall and trim conditions allow. Holding range of holder arm (hold open arm): 85°-180°. If butt, frame and wall conditions permit, closer will allow door to open 180°. Minimum top rail width required 2-1/2" for regular and hold open arm.

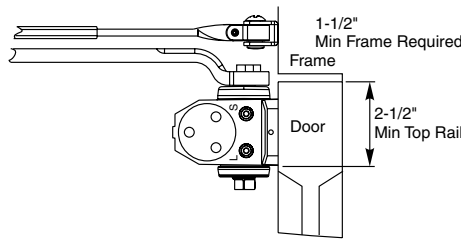
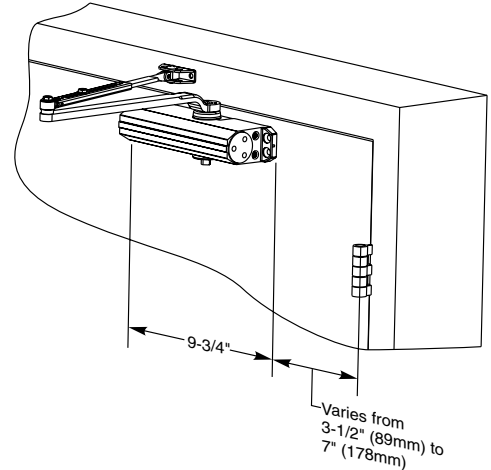
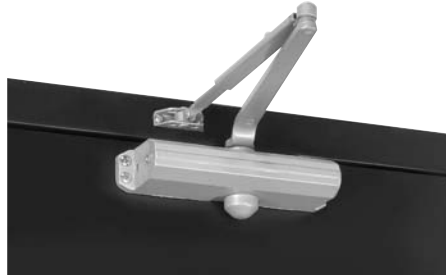

Approx. 180° Door opening with normal conditions

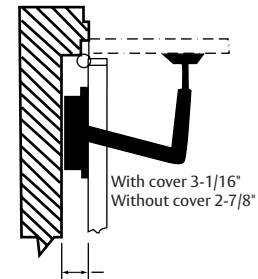
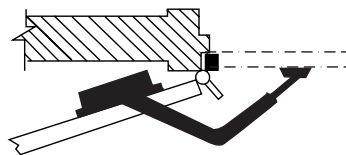

Parallel Arm Application

Closer mounts on top rail on stop side of door. Minimum top rail 5-1/4". As door opens, closer swings with door and gives full head room in door opening. For use on doors opening either in or out. Also used on two doors hung on the same frame with closer mounted between doors with a minimum of 5-1/4" in between doors. When two closers are used on different doors inside the same frame, the minimum door size is 46".

Standard Mounting: Standard mounting provides maximum power allowing door to open 100°. Holding range of holder arm (hold open arm): 85°-100°.

Alternate Mounting: Closer installed to allow for 180° opening. Range of hold open arm from 85-180°. Minimum width of stop required to mount foot bracket of arm is 1". Minimum mounting space required between two doors is 5-9/16" for regular arms and for holder arms.

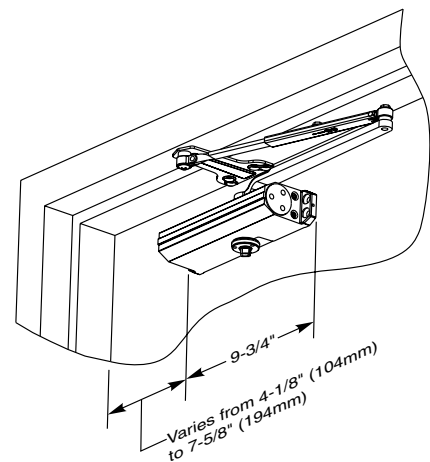
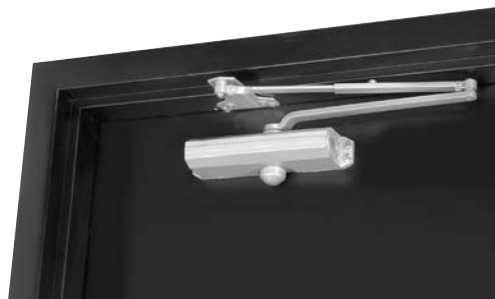

Copyright © 2016-2019, SARGENT Manufacturing Company. All rights reserved. Reproduction in whole or in part without the express written permission of SARGENT Manufacturing Company is prohibited. Patent pending and/or patent www.assaabloydss.com/patents.

Applications & Accessories

1131 Series Door Closers

Top Jamb Application

Closer mounts on top casing of push side of door.

As door opens, closer arm swings with door. Mounting for reveals up to 3".

Provides maximum power allowing door to open 100°. Holding range of holder arm (hold open arm): 85°-100°.

Alternate mounting: Closer installed to allow hinge to allow for 180° opening reveals less than 2". Range of hold open arm from 85-180°.

Minimum rail width on top casing required is 1-3/4". Minimum door rail width required to mount closer foot is 2-1/4", when frame without head stop is used (flush header).

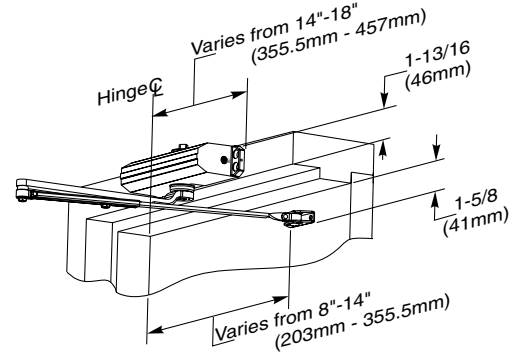
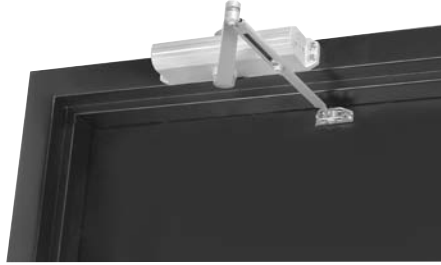

Consult factory if door weight exceeds 250 lbs.

Optional Accessories

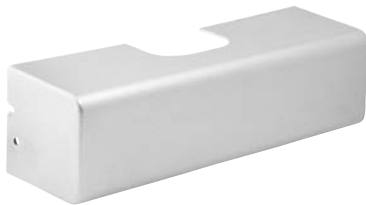

Full size non-handed high Impact cover secured by two machine screws

Specify suffix "C" when ordering.

To order cover separately, use P/N 60-0535 x finish

Brackets (Included)

Regular Parallel "RU" Arm Bracket

Converts regular standard arm to parallel arm

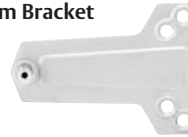

Hold-Open "HU" Arm Bracket

Converts the hold-open standard arm to hold-open parallel arm



581-1 Blade Stop Kit

Kit includes longer fasteners and 1/2" thick metal spacer for use with 1/2" blade stops commonly found on store front aluminum frames

Used with JP9 and JHP9 arms

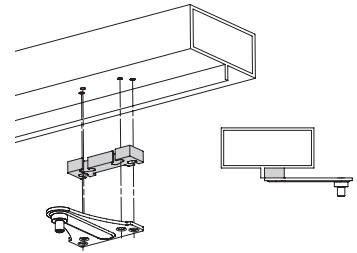

Copyright © 2016-2019, SARGENT Manufacturing Company. All rights reserved. Reproduction in whole or in part without the express written permission of SARGENT Manufacturing Company is prohibited. Patent pending and/or patent: www.assaabloydss.com/patents.

Architectural Specifications

2.0 DOOR CLOSERS

- A. Door closers shall be 1131 Series as manufactured by SARGENT Manufacturing Company, New Haven, CT.
- B. Door closers shall meet ANSI/BHMA A156.4, Grade 1 requirements.
- C. Door closers shall be UL listed (US and Canada) for use on fire doors.
- D. Door closer shall meet the requirements of UL 10C positive pressure fire tests.
- E. Provide closers adjustable from sizes 1-6.
- F. Closers shall be non-handed to meet a variety of door conditions and design requirements.
- G. Closing speed, latching speed and backcheck shall be controlled by separate key operated, captivated valves.
- H. Closers shall have heat treated rack and pinion construction.
- I. An increase of 15 percent in closing power shall be provided by means of adjustment of the arm leverage at the foot connection. (Standard Arm mount)
- J. Closer main arms shall be heavy duty steel.
- K. Door closer bodies:
 - 1. One piece door closer body shall be of high strength cast aluminum alloy.
 - 2. Adjustment valves shall be captivated and non-critical.
 - 3. Closer spindle shaft shall be sealed hydraulically with an "O" ring.
- L. Specify desired option: (SRI) Special Rust Inhibitor Process.
- M. Projection of closer body from door shall not exceed 2-3/16" (56mm).
- N. Closer covers shall be constructed of high impact plastic material of flame retardant grade, secured by machine screws.
- O. Closers shall be suitable for standard, top jamb, and parallel arm type applications when provided with proper brackets and arms.
- P. Door closers shall have a 25 year limited warranty.

How To Order & Packing

1131 Series Door Closers

How to order complete door closer

Example

Model #	1131	1131
Arm Type	RU or HU (Hold open)	1131RU
Finish	EB – Bronze Enamel to match 10B EN – Aluminum Enamel	1131 RU EB

NOTE:

- Door closer warranty becomes void if the closer is installed on the exterior side of a door in the exterior wall of a building.
- It is strongly recommended, and may be required on fire door assemblies, that doors having a door closer be hung on ball-bearing or anti-friction hinges or pivots. Consult local authority having jurisdiction.
- Failure to use fasteners supplied with closer may void factory warranty.
- Fasteners for fire/smoke door assemblies must conform to NFPA 80. In some applications additional fasteners may be mandated by NFPA 80 that are not shipped with standard SARGENT product, such as sleeve-nuts/sex-nuts or thru bolts and grommet nuts.
- Information provided is based on 1-3/4" (44mm) x 7' (2.13m) standard weight doors swinging to 110°. Other conditions (such as door height or weight; or wind/draft conditions) may require adjustment of spring setting, selection of a larger size closer or different closer.

Special Rust Inhibitor Process (SRI)

Additional process provides an extra layer of protection for extreme corrosive environments. Available with powder coated finishes only (closer body),specify SRI- when ordering.

Packing

Approximate shipping weights and piece count per case		
1131 Series	6 per carton	39 lbs case

The ASSA ABLOY Group is the global leader in access solutions. Every day, we help billions of people experience a more open world.

ASSA ABLOY Opening Solutions leads the development within door openings and products for access solutions in homes, businesses and institutions. Our offering includes doors, frames, door and window hardware, locks, perimeter fencing, access control and service.



SARGENT Manufacturing Company
100 Sargent Drive
New Haven, CT 06511 USA
800-727-5477
www.sargentlock.com

Founded in the early 1800s, SARGENT® is a market leader in locksets, cylinders, door closers, exit devices, electro-mechanical products and access control systems for new construction, renovation, and replacement applications. The company's customer base includes commercial construction, institutional, and industrial markets.
Copyright © 2016-2019, SARGENT Manufacturing Company. All rights reserved. Reproduction in whole or in part without the express written permission of SARGENT Manufacturing Company is prohibited. Patent pending and/or patent www.assaabloydss.com/patents.