

Experience a safer
and more open world

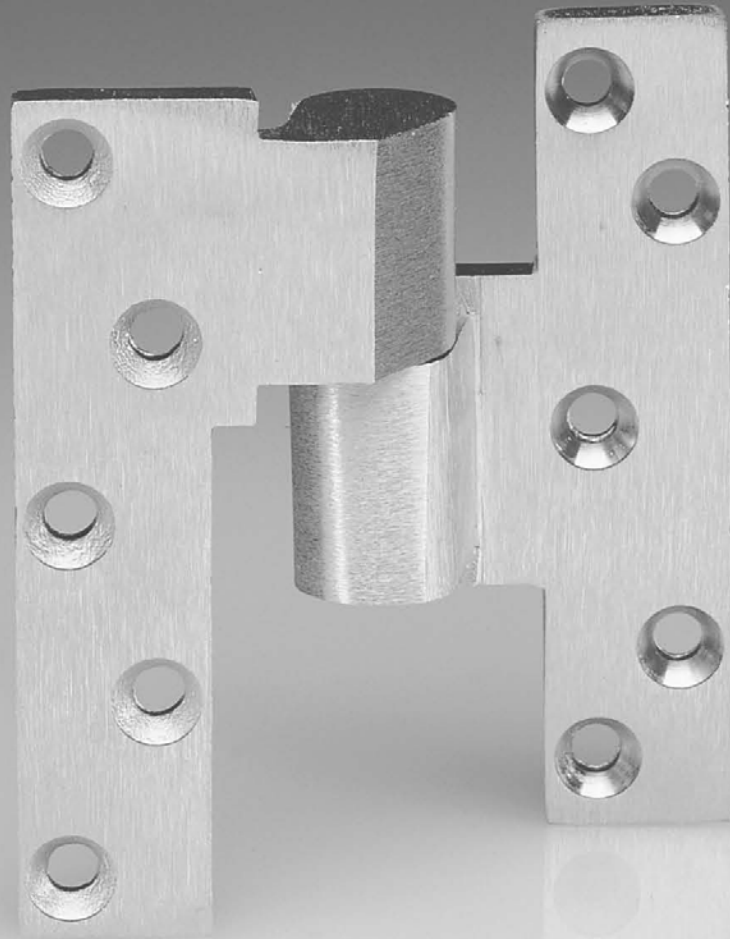

PIVOTS AND PIVOT SETS

Architectural Solutions for Durable
and Efficient Hanging of Doors

GENERAL INFORMATION, HOW TO SELECT PRODUCT

Pivot sets provide the best possible means of hanging a door. They are designed to work with the laws of physics to provide long-lasting performance and reliability.

- The weight of the door is supported at the bottom by the floor
 - Uses principles of gravity to its advantage
 - Door swings with less resistance
 - Heavier doors can be accommodated
- Reduced stress on frame
 - Fasteners are in shear, not tension
 - Eliminates door sag
 - Vertically adjustable
- Heavy-duty hardened steel spindles
 - Thrust bearing supports vertical load
 - Needle bearings and bushings for lateral force
 - Extra heavy-duty models also have an additional surface applied thrust bearing to handle heavier or high-traffic doors
- Offset pivots provide better weight distribution and can accommodate taller doors
- Intermediate pivots are used for alignment and to ensure proper installation of bottom pivot or floor closer
- Center hung pivots are used for aesthetics or if the pivot point is going to be moved nearer the lock edge of the door
- **PIVOTS DO NOT RETURN DOORS TO CENTER.** Pivots in this section are for door hanging means only. For door control see door closer catalog sections.

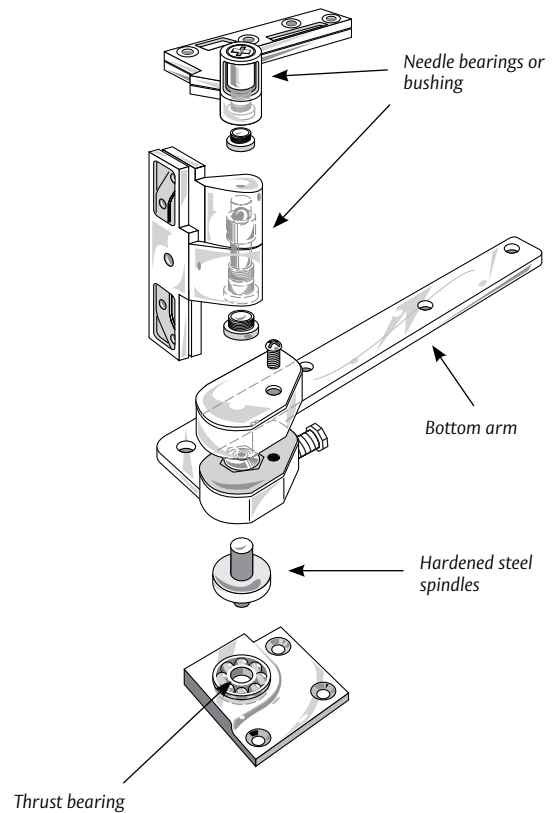

147 Pivot set and M19 Intermediate pivot shown (recommended)

1. OFFSET VS. CENTER HUNG APPLICATION

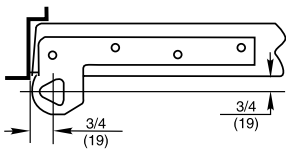

3/4" Offset

Pivot point located 3/4" from the heel edge of the door and 3/4" from face of door.

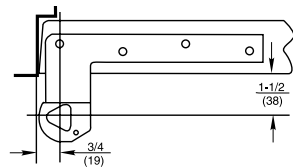

1-1/2" Offset

Pivot point located 3/4" from the heel edge of the door and 1-1/2" from face of door. Extended offsets should be used when there is cladding on the face of door or trim on the frame.

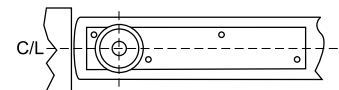

Center Hung

Pivot point centered in thickness of door.

2. SIZE OF DOOR (WIDTH, HEIGHT, THICKNESS)

Estimated door weights pounds per square foot (PSF)	DOOR THICKNESS		
	1-3/4"	2-1/4"	3"
Door Material	1-3/4"	2-1/4"	3"
Hollow Metal	6.5	7	—
Solid Core Wood	7	9	11.5
Aluminum/Glass Storefront	3.5	4	—
Bullet Resistant	20	21	—
MDF	7	9	11.5
Tempered Glass	GLASS THICKNESS		
	3/8"	1/2"	3/4"
Lead Lining (add to door weight)	LEAD THICKNESS		
	1/16"	1/8"	1/4"
3/4" Cladding (add to door weight)	CLADDING MATERIAL		
	Wood	Stone	Bronze
	3	10.5	28

Example: 3'6" x 8' x 1/2" Tempered Glass Door
Door: 28sq ft x 7lb./sq ft = 196lbs.
For doors of other sizes, consult factory

Example: 3' x 7' x 1-3/4" WD x 1/4" Lead lining
Door: 21sq ft x 7lb./sq ft = 147lbs.
Lead Lining: 9.75 = 204.75lbs.
Total Door weight: 351.75lbs.

3. CYCLES

APPLICATION	DAILY CYCLES	YEARLY CYCLES	
Large department store entrance	5,000	1,500,000	High
Large office building entrance	4,000	1,200,000	
Theater entrance	1,000	365,000	
School entrance	1,250	225,000	
School restroom door	1,250	225,000	
Store or bank entrance	500	150,000	
Office building restroom door	400	118,000	
School corridor door	80	15,000	Average
Office building corridor door	75	22,000	
Store restroom door	60	18,000	
Residential entrance door	40	15,000	Low
Residential restroom door	25	9,000	
Residential hallway door	10	3,600	
Residential closet door	6	2,200	



ASSA ABLOY

Experience a safer
and more open world

OPTIONS, CERTIFICATIONS, WARRANTY, SPECIFICATIONS

Door Thickness – Suffix 1-3/4", 2", 2-1/4", 2-1/2" or 3"

When ordering L series pivot for lead-lined doors, the thickness of the door must be given. The purpose of the L product is to have screws spaced so they straddle the lead in the center of the door. Also used when lead lining is under the skins of the door. Recommended for use on extra heavy or high traffic doors.

ElectroLynx® Connectors – Suffix QC – Number of Wires

The plug-in connectors, with easy color coded wire system, eliminate matching wires. Must be used with ASSA ABLOY doors, frames and hardware. Available 4, 6, 8 or 12 wires for most products.

Extended Spindle – Suffix extra length needed

Any special coverings or severe door undercuts will affect the spindle height. In these applications, an extended spindle may be required. Most standard spindle heights accommodate door undercuts up to 1/2". Extended spindles available in 1/2" increments up to 2" longer than standard. See template.

Fire Rated – Prefix F 

Pivots for fire rated doors (up to 3 hours) include a steel top pivot and must have additional steel intermediate pivots. For F519 pocket pivot, door assemblies must have been tested with pocket pivots.

Handing

All offset pivots and pivot sets are handed. Suffix RH or LH.

CERTIFICATIONS

See individual sections for compliance with ANSI A156.4 standards.

LIMITED WARRANTY

Pivot sets are warranted for 2 years for defect. See Norton Rixson Price Book for specific details of the limited warranty.

SPECIFICATIONS

All pivots and pivot sets shall be of one manufacturer. All heavy-duty pivots shall have a minimum of 2 bearings internal to the bottom pivot. One shall be a thrust bearing and the other a needle bearing. Separate bearing surfaces shall be in the top pivot. Lead-lined door units and high traffic pivots shall have additional thrust bearing. Fire rated pivot sets shall have steel top pivots. Fire rated doors require steel intermediate pivots.

Less Top Pivot – Suffix LTP

For conditions requiring special top pivots or for arch top doors, the pivot set should be ordered less top pivot – LTP. For offset installations, an additional load bearing intermediate (side jamb) M190 pivot is required. All intermediate pivots for that opening should be M190's, not M19's.

1-1/2" Offset – Suffix 1-1/2

Offset is the distance from the face of the door to the pivot point. Extended offsets should not be used unless there is cladding on the face of the door or there is trim to clear on the frame. 1-1/2" offset arms and pivots are for doors with cladding or trim that project 3/4" from the face of the door. The greater the offset the less weight can be carried by the pivot.

Special Layouts – Suffix SPLO#

Unique installations or specially engineered products are called special layouts. These numbers must be assigned by the technical support department and they must be called out specifically by their number when ordering.

Twenty-minute label – Suffix - 20 

This UL rating is for 20-minute assemblies. Product with this rating has an authorized label.

Model M190

Application

- Heavy-Duty Full Mortise
- Handed

Product Description & Features

- Used when frame condition does not allow standard top pivot
- Lateral load-bearing
- Maintains door alignment
- Aids in installing floor closers and bottom pivots
- Heavy-duty needle bearing
- 3/4" (19mm) offset standard
- Door edges must be beveled in 1/8" in 2"
- Non-ferrous base metal
- Doors 60" (1524mm) to 90" (2286mm) in height should use one intermediate pivot. Each additional 30" (762mm) warrants another intermediate pivot
- Furnished with wood and machine screws

Optional Features

- Available for 1-1/2" (38mm) offset

Compliance

- Available for fire door assemblies (ferrous material) – specify FM190
- For 20-minute label suffix "-20" to part number
- ANSI C07321/C07371



Technical Information

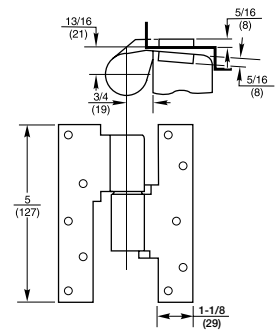

Model ML19

Application

- Full Mortise
- Lead-Lined, Heavy or High Traffic Doors
- Handed

Product Description & Features

- Load-bearing
- Screw holes spaced to straddle lead lining in center of door. Also use on extra heavy or high traffic door
- Maintains door alignment
- Aids in installing closers and pivots
- Door edges must be beveled in 1/8" in 2"
- Available to accommodate door thicknesses 1-3/4" (44mm), 2" (51mm), 2-1/4" (57mm), 2-1/2" (64mm), or 3" (76mm) – specify thickness when ordering
- Non-ferrous base material
- Doors 60" (1524mm) to 90" (2286mm) in height should use one intermediate pivot. Each additional 30" (762mm) warrants another intermediate pivot
- Furnished with wood and machine screws

Compliance

- Available for fire door assemblies – 1-3/4" (44mm) door only – specify FML19
- For 20-minute label suffix "-20" to the part number
- ANSI C07311

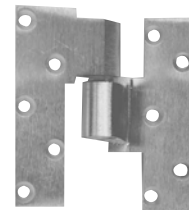

Technical Information

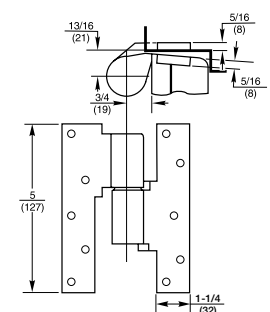

ASSA ABLOY

Experience a safer
and more open world