

CATALOG



ASSA ABLOY

Experience a safer
and more open world

HEAVY DUTY & SHALLOW DEPTH FLOOR CLOSERS

COMPLETE DOOR CONTROL FOR
EXTERIOR AND INTERIOR DOORS,
WHERE CONCEALMENT IS DESIRED

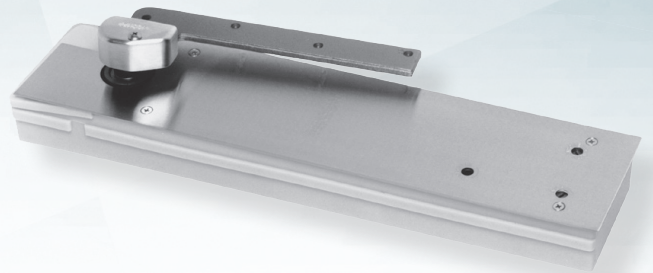
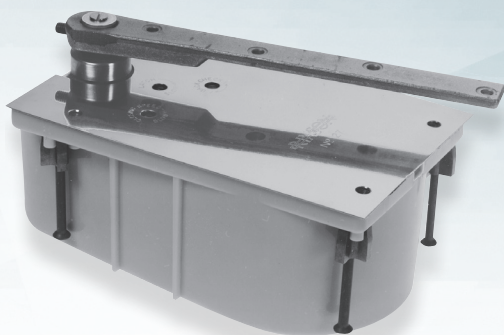

How to Select Product3-4

Heavy-Duty Floor Closers

General Information.....5
 Glossary of Terms.....6-7
 Certifications, Limited Warranty, Specifications.....7
 Offset Hung Models
 278
 27-180.....9
 127.....10
 42711
 L2712
 L27-180.....13
 Q/QT2714
 HM2715
 20.....16
 Intermediate Pivots & Hinges
 119, M19, M190.....17
 ML19, FA1918
 Independently Hung Model
 F32719
 Center Hung, Single Acting Models
 28.....20
 28 x 554 Arm21
 H28, H28 x 587 Arm22
 32823
 428.....24
 EH28, EH28 x 587 Arm.....25
 Center Hung, Double Acting Models
 30.....26
 4027
 H40, H40 x 587 Arm28
 Optional Center Hung Top Pivots
 345, H345.....29
 How To Order.....30
 Product Comparison Charts.....31-33
 Parts List.....34-45

Shallow Depth Floor Closers

General Information..... 46
 Limited Warranty, Specifications..... 46
 Glossary of Terms.....47
 Offset Hung Models
 5148
 Q/QT51.....49
 HM51.....50
 Intermediate Pivots & Hinges
 M19, M19051
 Independently Hung Model
 F53, F531052
 Intermediate Pivots
 51953
 Center Hung, Single Acting Models
 5054
 50 x 554 Arm.....55
 504056
 Center Hung, Double Acting Models
 5020.....57
 Optional Center Hung Top Pivots
 34558
 How To Order.....59
 Product Comparison Charts.....60
 Parts List.....61-66

HOW TO SELECT A PRODUCT

FLOOR CLOSERS

1. Offset Vs. Center Hung Application

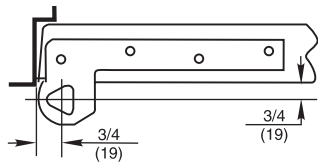

3/4" Offset

Pivot point located 3/4" from the heel edge of the door and 3/4" from face of door

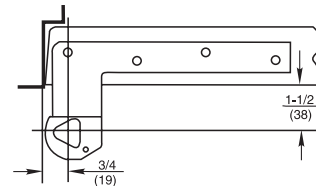

1-1/2" Offset

Pivot point located 3/4" from the heel edge of the door and 1-1/2" from face of door. Used on doors with cladding on face or trim on frame

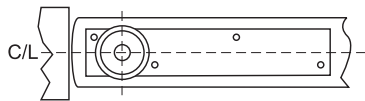

Center Hung

Pivot point centered in thickness of door. Distance from heel edge can vary 2-3/4" and up. **Not for use on fire rated doors.**

2. Size of Door (Width, Height, Thickness)

Door Material	Door Thickness		
	1-3/4"	2-1/4"	3"
Hollow Metal	6.5	7	—
Solid Core Wood	7	9	11.5
Aluminum/Glass Storefront	3.5	4	—
Bullet Resistant	20	21	
MDF	7	9	11.5
Glass Thickness			
Tempered Glass	3/8"	1/2"	3/4"
	5	7	9.75
Lead Thickness			
Lead Lining (add to door material weight)	1/16"	1/8"	1/4"
	5	8	9.75
Cladding Material			
3/4" Cladding (add to door material weight)	Wood	Stone	Bronze
	3	10.5	28

Example: 3' x 7' x 1-3/4" WD x 1/4" Lead lining
 Door: 21sq ft x 7lb./sq ft = 147lbs
 Lead Lining: 21sq ft x 9.75lb./sq ft = 204.75lbs
 Total Door weight 351.75lbs

Example: 3'6" x 8' x 1/2" Tempered Glass Door
 Door: 28sq ft x 7lb./sq ft = 196lbs

For doors of other sizes consult factory

3. Expected Frequency of Door Opening

Application	Daily	Yearly	
Large department store entrance	5,000	1,500,000	High
Large office building entrance	4,000	1,200,000	
Theater entrance	1,000	365,000	
School entrance	1,250	225,000	
School restroom door	1,250	225,000	
Store or bank entrance	500	150,000	
Office building restroom door	400	118,000	
School corridor door	80	15,000	Average
Office building corridor door	75	22,000	
Store restroom door	60	18,000	
Residential entrance door	40	15,000	
Residential restroom door	25	9,000	Low
Residential hallway door	10	3,600	
Residential closet door	6	2,200	

How to Determine Hand of Door

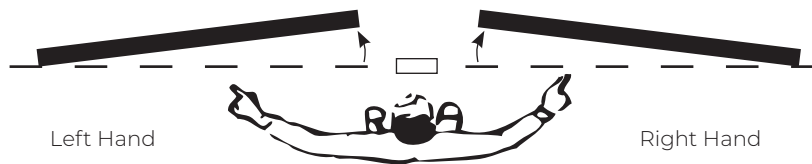

Face a door swinging open away from you. If it opens to the right, it is right handed. If it opens to the left, it is left handed.

GENERAL INFORMATION

FLOOR CLOSERS

Norton Rixson heavy-duty floor closers are ideal for supporting and controlling doors. Floor closers provide long-lasting performance and dependability. Heavy-duty closers are used on exterior or interior, medium to high traffic openings or for applications where the doors are very heavy.

Features and Benefits

- Weight of the door is supported by the bottom arm and floor
 - Door swings with less resistance
 - Reduces stress on the frame
 - Fasteners are in shear, not tension
 - Eliminates door sag
 - Doors can be adjusted vertically
- Bottom arm attaches directly to the closer spindle
 - A mechanical advantage that increases efficiency insuring that ICC/ANSI A117.1 compliant, lower opening forces will still close the door
 - One to one ratio of door swing to spindle rotation makes control more precise
- Closer is concealed in the floor
 - Aesthetics -the beauty of the opening is the focal point, not the closer
 - Vandal resistance -the mechanism is not exposed
 - Solution for arch top doors (offset models)
- Heavy-duty, hardened, one piece steel spindles
 - Designed to provide positive dead stop
 - Thrust bearings support vertical load
 - Needle bearings for lateral loads
 - L models have applied thrust bearings to handle extra heavy doors or doors with high traffic
- Helical torsion springs
 - Operates in the same direction as door movement – contributes to higher closer efficiency
 - Torsion spring has a longer life than compression springs

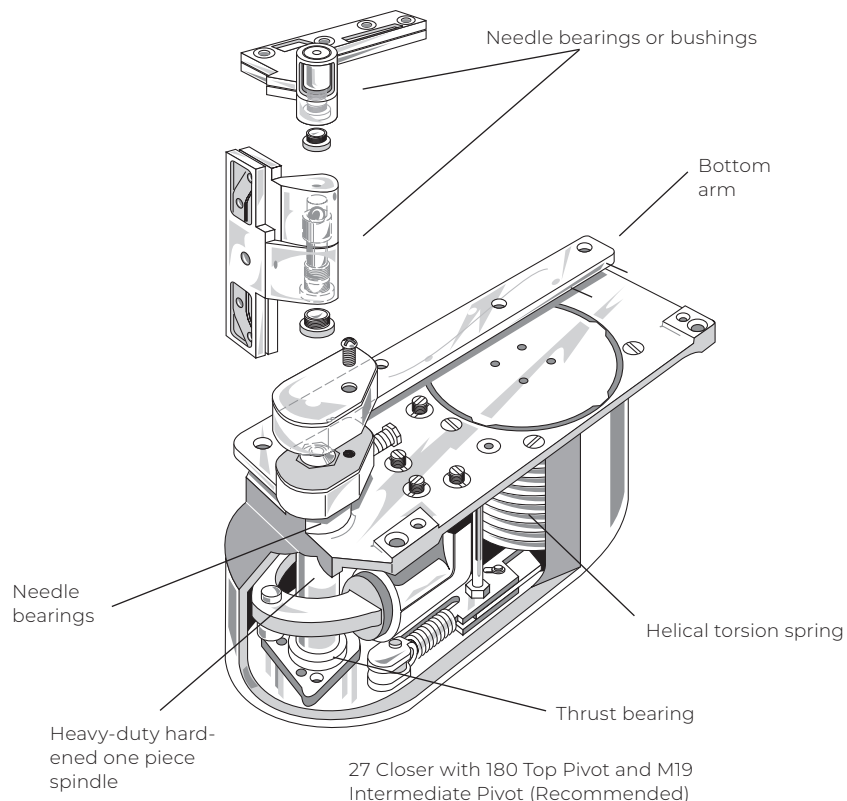

Automatic Hold Open – Suffix A

These closers hold the door open. This feature cannot be changed in the field. Models 27-180, 30 & 40 only.

Cold Weather Fluid – Suffix CWF

Cold weather fluid should be specified for exterior doors in consistently cold climates under 32° F for weeks at a time. The hydraulic fluid is of a lower viscosity to prevent sluggish closing. Cannot be used with the delayed action feature.

Cover Pan (Terrazzo) – Suffix Part Number

Closers should always be accessible. They should never be buried beneath flooring materials. A cover pan sits on top of the closer and has the flooring material set in it. This way the sight line for the floor is consistent. Cover pans may require closers with longer spindles. See cover pan template to determine spindle length needed.

Degree of Swing – Follows Model Number

Single acting heavy-duty floor closers have a deadstop. This means that the door cannot go past a certain point. If ordered as a hold open closer, the hold open position is exactly the same as the deadstop. The degrees available are 85°, 90°, 95° or 105° (180° for model 27 only). It is recommended that the maximum degree of swing be ordered.

Double acting closers have a deadstop at 103° and are available with hold open options at 90° or 100°.

Delayed Action – Prefix DA

After full open, permits door to remain ajar (at 70 degrees) for up to 40 seconds. Operates by separate valve and can be shut off if not needed. Not available on closers with hold open feature.

Door Thickness – Suffix 1-3/4, 2, 2-1/4, 2-1/2 or 3

When ordering L product for lead lined doors, the thickness of the door must be given. The purpose of the L product is to have screws spaced so that they straddle the lead in the center of the door. Also used when lead lining is under the skins of the door. Recommended for use on extra heavy or high traffic doors.

Extended Spindle – Suffix Extra Length

Any special floor coverings, or severe door undercuts, will affect the spindle height. In these applications an extended spindle may be required. See product template to determine if an extended spindle is needed. Extended spindles available in 1/2" increments up to 2" longer than standard.

Fire Rated – Prefix F

Closer packages for fire rated doors (up to 3 hours) include a steel top pivot and must have additional steel intermediate pivots. These closers are non-hold open.

Hand- Suffix RH or LH

All single acting floor closers are handed. All double acting floor closers (30, 40, H40) are non-handed.

Less All Parts – Suffix LAP

If a closer is needed for replacement, the arm, cover, cement case, top pivot and floor plate are omitted.

Less Cement Case – Suffix LCC

For existing installations or when cement case has been sent earlier in construction. Closer will be packaged without the cement case.

Less Floor Plate – Suffix LFP

When thresholds or cover pans are being used, the closer doesn't need the decorative floor plate.

Less Top Pivot – Suffix LTP

For unusual head conditions, where the top pivot cannot be used, the closer is shipped without the top pivot. For offset installations, an additional load bearing intermediate (side jamb) M190 pivot is required. All intermediate pivots for that opening should be M190's, not M19's.

Non Hold Open – Suffix N

These closers do not hold the door open. This feature cannot be changed in the field.

1-1/2" Offset – Suffix 1-1/2

Offset is the distance from the face of the door to the pivot point. Extended offsets should not be used unless there is cladding on the face of the door or there is trim to clear on the frame. 1-1/2" offset arms and pivots are for doors with cladding or trim that project 3/4" from the face of the door.

Physically Handicapped – Prefix PH

To comply with ICC/ANSI A117.1 established by the Americans with Disabilities Act. PH prefix indicates 5 pounds of opening force, based at 30" from centerline of pivot. PH closers may not be used on labeled fire doors or exterior doors. Norton Rixson accepts no responsibility for PH closers and door latching. Also, be advised that ADA guidelines DO NOT apply to fire rated openings or exterior doors.

8-1/2 Lbs. Opening Force – Prefix PH Suffix 8-1/2

This is a lighter than normal opening force. Be aware that this may not be strong enough to close fire rated or exterior doors. Norton Rixson accepts no responsibility for PH closers and door latching. Also, be advised that ADA guidelines DO NOT apply to fire rated openings or exterior doors.

GLOSSARY OF TERMS

FLOOR CLOSERS

Sealed Closer – Prefix SC

This option for exterior doors or interior doors, with heavy exposure to water or cleaning solvents, protects the body. The closer body is placed in the cement case. A stainless steel cover plate is then gasketed and fastened to the cement case. This must be ordered with closer and cannot be ordered less the cement case.

Selective Hold Open – Suffix S

These closers can be set to hold open or non-hold open. This is done via a screw control on the top of the closer. Available on Models 27 and 28 only.

Special Layouts – Suffix SPLO

Unique installations or specially engineered products are called special layouts. These numbers must be assigned by the technical support department and they must be called out specifically, by their number, when ordered.

Twenty Minute Label – Suffix -20

This UL rating is for 20 minute doors. Pivots are brass base material and include a visible label.

Wood Door – Prefix W

When using a center hung product with the centering arm (e.g. 28, 30 or 40) a special plate and less obtrusive adjusting screws are needed for wood doors. This plate is reinforcement to the deep mortise required for that arm, protecting veneer.

CERTIFICATIONS

See individual sections for compliance with ANSI A156.4 standards.

LIMITED WARRANTY

Norton Rixson heavy-duty floor closers models 27, 28, 30 and 40 are warranted for 10 years against defect. The model 20 closer carries a 2 year warranty. See Price Book for specific details of the limited warranty.

SPECIFICATION

Floor closers shall be heavy-duty model 27 (offset) or model 28 (center hung). All closers shall be handed. Choose appropriate functions and strengths to accommodate lead lining, extra high traffic, fire rating, independently hung or quick install models. These closers shall have separate and independent checking valves, to control latch speed, closing speed and adjustable hydraulic backcheck. All single acting closers shall have a built in dead stop feature. All closers shall have one piece spindle assembly. Extra heavy-duty closers shall have minimum of two thrust bearings and one needle bearing. Closers shall not have compression spring.

MODEL 27

Application

- Single Acting, Handed
- Exterior or Interior Doors
- Weight to 450 lbs.*
- Door Width up to 4'0" (1219mm)

Product Description & Features

- 180 top pivot included
- M19 intermediate pivot(s) required (order separately)
- Available non-hold open (N) or selective hold open (S) at same degree as dead stop
- Built-in positive dead stop prevents door from swinging beyond the desired opening degree (specify 85°, 90°, 95°, 105°)
- Separate and independent valves for closing speed, latch speed and backcheck
- Vertical door adjustment
- Available with floor plate or threshold installation (floor plate shown)
- Cylolac, rust-proof cement case
- For arch top doors or applications when the 180 top pivot cannot be used, supply at least two each M190 load-bearing intermediate pivots, mounted together at the top of the straight vertical edge

Optional Features

- Delayed action option-prefix "DA" (non-hold open closers only)
- Cold weather fluid available – specify "CWF" (not available for closers with "DA")
- Sealed closer option – specify "SC"
- Available 1-1/2" offset, for doors with 3/4" cladding or frames with applied molding, maximum door weight 250 lbs.
- Extended spindles available in 1/2" increments up to 2" longer than standard
- Doors 60" (1524mm) to 90" (2286mm) in height should use one intermediate pivot. Each additional 30" (762mm) warrants another intermediate pivot
- Furnished with wood and machine screws

Compliance

- Models available to meet ICC/ANSI A117.1 low opening force requirements, prefix "PH". (For 8-1/2 lbs. of opening force prefix PH and suffix 8-1/2 lbs.)
- For fire rated openings (up to 3 hour assemblies) prefix "F". This package will be supplied with a F180 steel top pivot and a non-hold open closer. FM19 intermediate pivot required (order separately)
- UL listed closers cannot have PH option
- For 20-minute labeled doors suffix "-20" to the part number
- ANSI/C06041/C06051

*Door size & weight guidelines are determined using the appropriate number of intermediate pivots

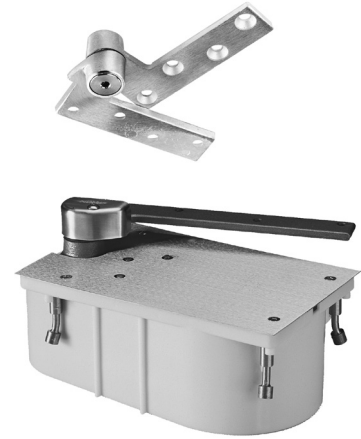

TECHNICAL INFORMATION

(Frame stop required)

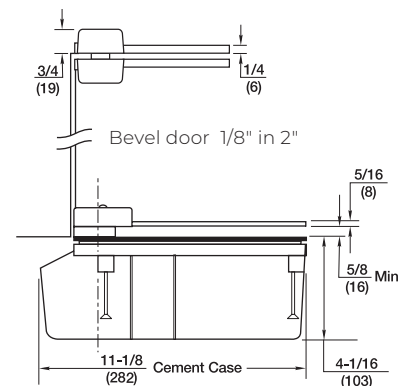
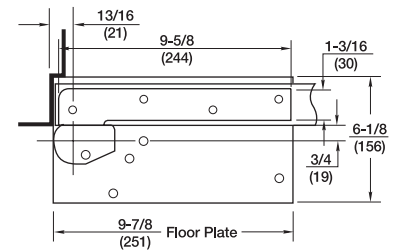
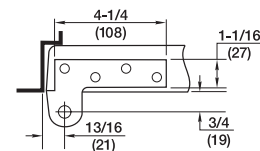

3/4" OFFSET HUNG FLOOR CLOSERS

MODEL 27-180

Application

- Single Acting, Handed
- Exterior or Interior Doors
- Weight to 450 lbs.*
- Door Width up to 4'0" (1219mm)

Product Description & Features

- 180 top pivot included
- M19 intermediate pivot(s) required (order separately)
- Available non-hold open (N) or automatic hold open (A)
- Maximum opening 180°, auxiliary floor or wall stop recommended
- Separate and independent valves for closing speed and latch speed
- Adjustable hydraulic backcheck
- Vertical door adjustment
- Available with floor plate or threshold installation (floor plate shown)
- Cicolac, rustproof cement case
- For arch top doors or applications where a 180 top pivot cannot be used, supply at least two each M190 load-bearing intermediate pivots, mounted together at the top of the vertical edge
- Doors 60" (1524mm) to 90" (2286mm) in height should use one intermediate pivot. Each additional 30" (762mm) warrants another intermediate pivot
- Not available with delayed action (DA)
- Furnished with wood and machine screws

Optional Features

- Cold weather option – specify "CWF"
- Sealed closer option – specify "SC"
- Available 1-1/2" offset, for doors with 3/4" cladding or frames with applied molding, maximum door weight 250 lbs.
- Extended spindles available in 1/2" increments up to 2" longer than standard

Compliance

- Models available to meet ICC/ANSI A117.1 low opening force requirements, prefix "PH". (For 8-1/2 lbs. of opening force prefix "PH" and suffix "8-1/2 lbs.")
- For fire rated openings (up to 3 hour assemblies) prefix "F". This package will be supplied with a F180 steel top pivot and a non-hold open closer. FM19 intermediate pivot required (order separately)
- UL labeled closers cannot have PH option
- For 20-minute labeled doors suffix "-20" to the part number

*Door size & weight guidelines are determined using the appropriate number of intermediate pivots



TECHNICAL INFORMATION

(Frame stop required)

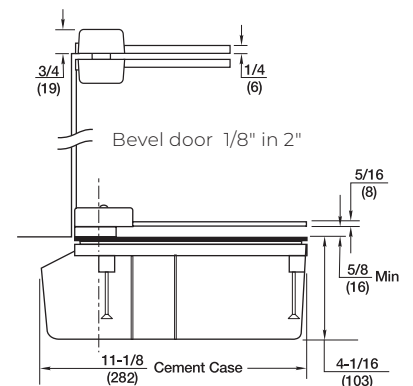
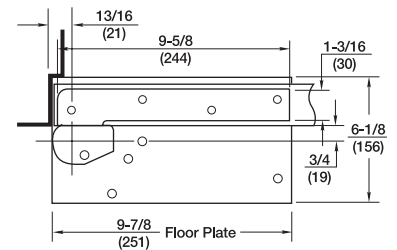
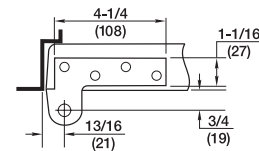

MODEL 127

Application

- Single Acting, Handed
- Exterior or Interior Doors
- Deep Reveal Applications
- Weight to 250 lbs.*
- Door Width up to 4'0" (1219mm)

Product Description & Features

- Recommended for applications where vertical movement of the door at installation is not possible, such as a door inset in a deep reveal or with no ceiling clearance
- Closer has a tapered spindle and uses a unique bottom arm to allow door installation
- 180 top pivot included
- 119 intermediate pivot(s) recommended for non-fire rated opening (order separately)
- Available non-hold open (N) or selective hold open (S) at same degree as dead stop
- Built-in positive dead stop prevents door from swinging beyond the desired opening degree (specify 85°, 90°, 95° or 105°)
- Separate and independent valves for closing speed, latch speed and backcheck
- Available with floor plate or threshold installation (floor plate shown)
- Cylolac, rustproof cement case
- For arch top doors or applications where a 180 top pivot cannot be used, supply at least two each M190 load-bearing intermediate pivots, mounted together at the top of the vertical edge. Do not use 119 intermediate pivot.
- Doors 60" (1524mm) to 90" (2286mm) in height should use one intermediate pivot. Each additional 30" (762mm) warrants another intermediate pivot

Optional Features

- Delayed action option – prefix "DA" (non-hold open closers only)
- Cold weather fluid option – specify "CWF" (not available for closers with "DA")
- Sealed closer option – specify "SC"
- Extended spindles available in 1/2" increments up to 2" longer than standard

Compliance

- Models available to meet ICC/ANSI A117.1 low opening force requirements, prefix "PH". (For 8-1/2 lbs. of opening force prefix PH and suffix 8-1/2 lbs.)
- For fire rated openings (up to 3 hour assemblies) prefix "F". This package will be supplied with a F180 steel top pivot and a non-hold open closer. FM19 intermediate pivot required (order separately)
- UL labeled closers cannot have PH option
- For 20-minute labeled doors suffix "-20" to the part number
- ANSI/C06041

*Door size & weight guidelines are determined using the appropriate number of intermediate pivots

*specify finish



TECHNICAL INFORMATION

(Frame stop required)

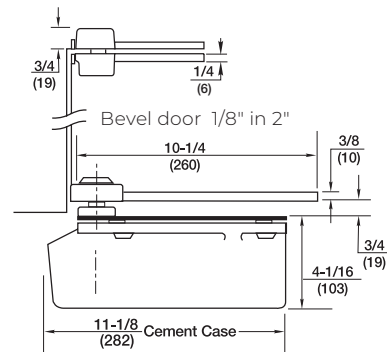
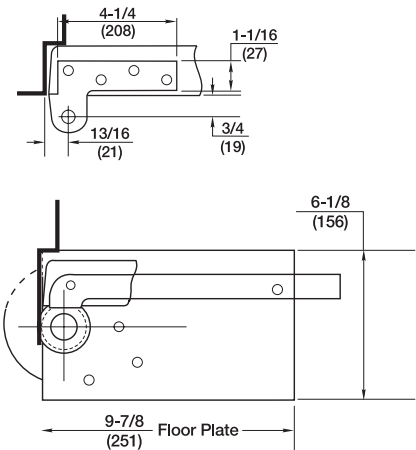

3/4" OFFSET HUNG FLOOR CLOSERS

MODEL 427

Application

- Single Acting, Handed
- Exterior or Interior Doors
- Deep Reveal/Alcove Applications
- Weight to 250 lbs.*
- Door Width up to 4'0" (1219mm)

Product Description & Features

- Recommended for applications where vertical movement of the door at installation is not possible, such as a door inset in an alcove with no ceiling or side jamb clearance
- Closer has a tapered spindle and uses a unique bottom arm
- 180 x 102 top pivot included
- 119 intermediate pivot(s) recommended (order separately)
- Available non-hold open (N) or selective hold open (S) at same degree as dead stop
- Built-in positive dead stop prevents door from swinging beyond the desired opening degree (specify 85°, 90°, 95° or 105°) Note: Alcove doors can rarely go beyond 90°
- Separate and independent valves for closing speed, latch speed and backcheck
- Available with floor plate or threshold installation (floor plate shown)
- Cyclocac rustproof cement case
- Doors 60" (1524mm) to 90" (2286mm) in height should use one intermediate pivot. Each additional 30" (762mm) warrants another intermediate pivot
- Not available for fire rated openings
- Furnished with wood and machine screws

Optional Features

- Delayed action option – prefix "DA" (non-hold open closers only)
- Cold weather fluid option – specify "CWF" (not available for closers with "DA")
- Sealed closer option – specify "SC"
- Extended spindles available in 1/2" increments up to 2" longer than standard

Compliance

- Models available to meet ICC/ANSI A117.1 low opening force requirements, prefix "PH". (For 8-1/2 lbs. of opening force prefix "PH" and suffix "8-1/2 lbs.")
- ANSI/C06041

**Door size & weight guidelines are determined using the appropriate number of intermediate pivots*



TECHNICAL INFORMATION

(Frame stop required)

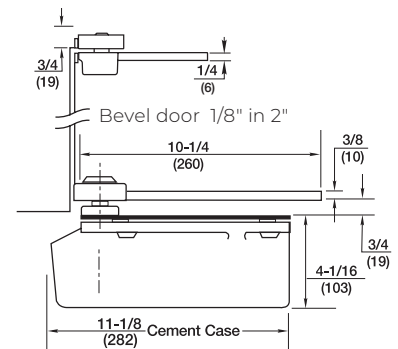
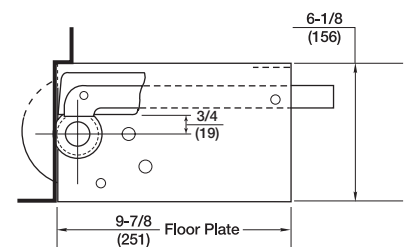
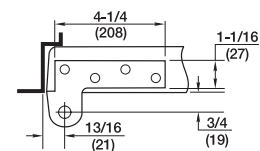

MODEL L27

Application

- Single Acting, Handed
- Exterior or Interior Doors
- Lead-Lined, Heavy, High Traffic Doors
- Weight to 1500 lbs.*
- Door Width up to 4'0" (1219mm)

Product Description & Features

- L180 top pivot included
- ML19 intermediate pivot(s) required (order separately)
- Heavy-duty bottom arm and top pivot with screw holes spaced to straddle lead lining, or for extra heavy or very high traffic doors.
- Available for the following lead-lined door thicknesses: 1-3/4" (44mm), 2" (51mm), 2-1/4" (57mm), 2-1/2" (63mm) or 3" (76mm)
- Available non-hold open (N) or selective hold open (S) at same degree as dead stop
- Built-in positive dead stop prevents door from swinging beyond the desired opening degree (specify 85°, 90°, 95° or 105°)
- Additional thrust bearing for greater load capacity
- Separate and independent valves for closing speed, latch speed and backcheck
- Vertical door adjustment
- Available with floor plate or threshold installation (floor plate shown)
- Cast iron cement case
- For arch top doors or applications where an L180 top pivot cannot be used, supply at least two each ML19-load bearing intermediate pivots, mounted together at the top of the vertical edge
- Doors 60" (1524mm) to 90" (2286mm) in height should use one intermediate pivot. Each additional 30" (762mm) warrants another intermediate pivot
- Furnished with wood and machine screws

Optional Features

- Delayed action option – prefix "DA" (non-hold open closers only)
- Cold weather fluid option – specify "CWF" (not available for closers with "DA")
- Sealed closer option – specify "SC"
- For extended offsets, consult factory
- Extended spindles available in 1/2" increments up to 2" longer than standard
- For extended offsets, consult factory

Compliance

- Models available to meet ICC/ANSI A117.1 low opening force requirements, prefix "PH". (For 8-1/2 lbs. of opening force prefix PH and suffix 8-1/2 lbs.)
- For fire rated openings (up to 3 hour assemblies) prefix "F". This package will be supplied with a FL180 steel top pivot and non-hold open closer. FML19 intermediate required (order separately). Note: UL listing for 1-3/4" thick doors only.
- UL labeled closers cannot have PH option
- For 20-minute labeled doors suffix "-20" to the part number
- ANSI/C06071

*Door size & weight guidelines are determined using the appropriate number of intermediate pivots

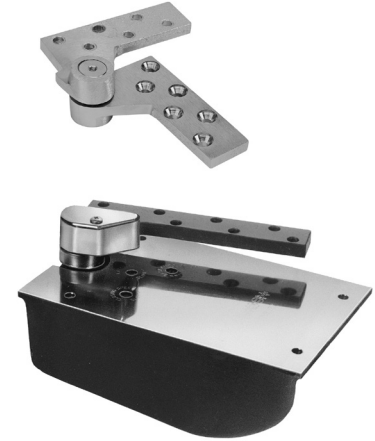

TECHNICAL INFORMATION

(Frame stop required)

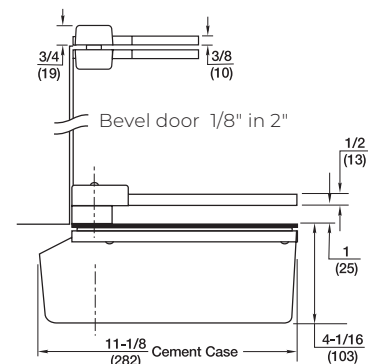
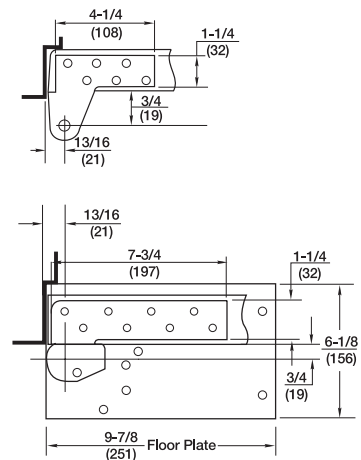

* 1-3/4" door thickness shown

3/4" OFFSET HUNG FLOOR CLOSERS

MODEL L27-180

Application

- Single Acting, Handed
- Exterior or Interior Doors
- Lead-Lined, Heavy, High Traffic Doors
- Weight to 1500 lbs.*
- Door Width up to 4'0" (1219mm)

Product Description & Features

- L180 top pivot included
- ML19 intermediate pivot(s) required (order separately)
- Heavy-duty bottom arm and top pivot with screw holes spaced to straddle lead lining, or for extra heavy or very high traffic doors.
- Available for the following lead-lined door thicknesses: 1-3/4" (44mm), 2" (51mm), 2-1/4" (57mm), 2-1/2" (63mm) or 3" (76mm)
- Available non-hold open (N) or automatic hold open (A) at 180°
- Built-in positive dead stop prevents door from swinging beyond 180° only
- Additional thrust bearing for greater load capacity
- Separate and independent valves for closing speed, latch speed and backcheck
- Vertical door adjustment
- Available with floor plate or threshold installation (floor plate shown)
- Cast iron cement case
- For arch top doors or applications where a L180 top pivot cannot be used, supply at least two each ML19 load bearing intermediate pivots, mounted together at the top of the vertical edge
- Doors 60" (1524mm) to 90" (2286mm) in height should use one intermediate pivot. Each additional 30" (762mm) warrants another intermediate pivot
- Furnished with wood and machine screws

Optional Features

- Delayed action option – prefix "DA" (non-hold open closers only)
- Cold weather fluid option – specify "CWF" (not available for closers with "DA")
- Sealed closer option – specify "SC"
- For extended offsets, consult factory
- Extended spindles available in 1/2" increments up to 2" longer than standard
- For extended offsets, consult factory

Compliance

- Models available to meet ICC/ANSI A117.1 low opening force requirements, prefix "PH". (For 8-1/2 lbs. of opening force prefix PH and suffix 8-1/2 lbs.)
- For fire rated openings (up to 3 hour assemblies) prefix "F". This package will be supplied with a FL180 steel top pivot and non-hold open closer. Furnish FML19 intermediate pivot (order separately). Note: UL listing for 1-3/4" thick doors only.
- UL labeled closers cannot have PH option
- For 20-minute labeled doors suffix "-20" to the part number
- ANSI/C06071

*Door size & weight guidelines are determined using the appropriate number of intermediate pivots

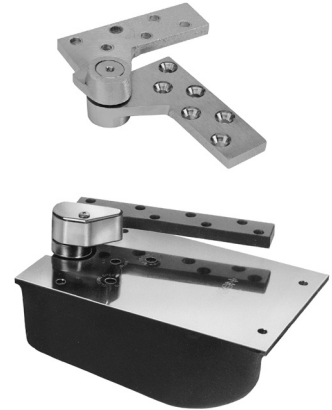

TECHNICAL INFORMATION

(Frame stop required)

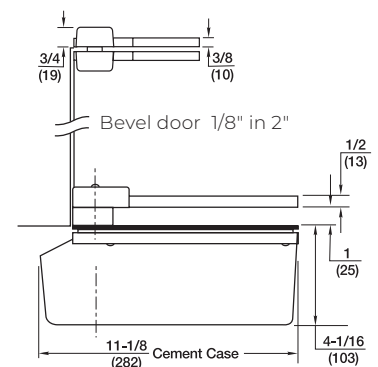
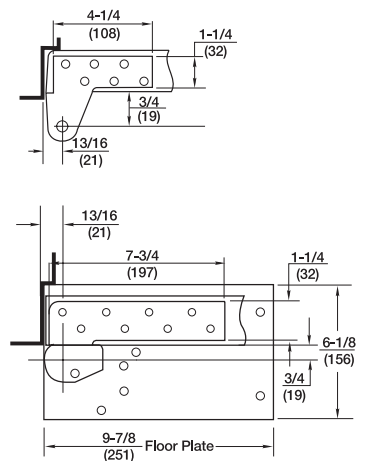

3/4" OFFSET HUNG FLOOR CLOSERS

MODEL Q27/QT27

Application

- Single Acting, Handed
- Exterior and Interior Doors
- Weight to 350 lbs.*
- Door Width up to 4'0" (1219mm)
- 1-3/4" Thick Only

Product Description & Features

- 180 top pivot included
- One M19 intermediate pivot included. *Closer cannot be ordered without the intermediate pivot*
- 3/4" offset only
- Available non-hold open (N) or selective hold open (S) at same degree as dead stop
- Built-in positive dead stop prevents door from swinging beyond the desired opening degree (specify 85°, 90°, 95°)
- Maximum door swing 95°
- Separate and independent valves for closing speed, latch speed and backcheck
- Vertical door adjustment
- Surface-attached bottom arm allows closer removal without demounting door
- Q closers have a floor plate (shown).
- For threshold application prefix "QT"
- Mortise arm with thru-bolt attachment
- Cylolac rustproof cement case
- Increased depth of cement case for easy closer removal
- For arch top doors, consult factory
- Doors 60" (1524mm) to 90" (2286mm) in height should use one intermediate pivot (included). Each additional 30" (762mm) or doors over 195 lbs. warrants another intermediate pivot
- Furnished with wood and machine screws

Optional Features

- Delayed action option – prefix "DA" (non-hold open closers only)
- Cold weather fluid option – specify "CWF" (not available for closers with "DA")
- Extended spindles available in 1/2" increments up to 2" longer than standard

Compliance

- Models available to meet ICC/ANSI A117.1 low opening force requirements, prefix "PH".
(For 8-1/2 lbs. of opening force prefix "PH" and suffix "8-1/2 lbs.")
- For fire rated openings (up to 3 hour assemblies) prefix F. This package will be supplied with a F180 steel top pivot, one FM19 intermediate pivot and a non-hold open closer
- UL labeled closers cannot have PH option
- For 20-minute labeled doors suffix "-20" to the part number
- ANSI/C06041/C06051

*Door size & weight guidelines are determined using the appropriate number of intermediate pivots



TECHNICAL INFORMATION

(Frame stop required)

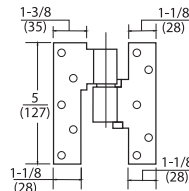
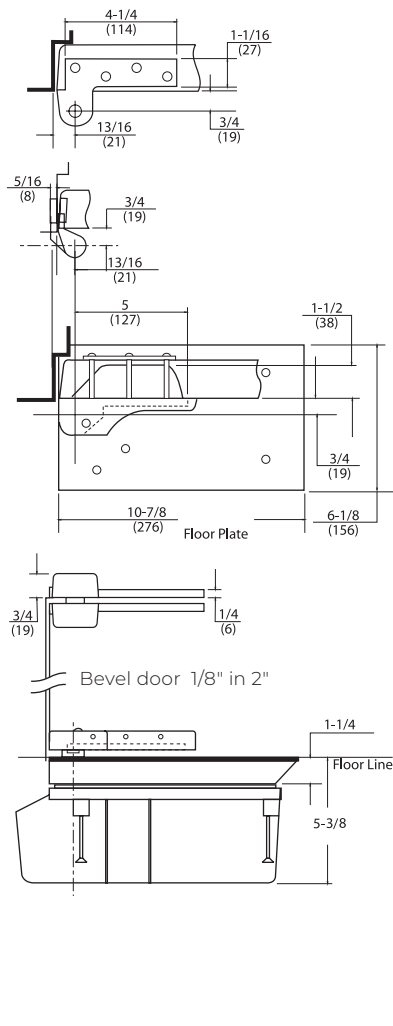

3/4" OFFSET HUNG FLOOR CLOSERS

MODEL HM27

Application

- Single Acting, Handed
- Exterior or Interior Doors
- 1-3/4" Hollow Metal Doors/Frames
- Weight to 250 lbs.
- Door Width up to 4'0" (1219mm)

Product Description & Features

- Designed for stock hollow metal doors and frames with standard weight 4-1/2" hinge preparation
- Includes three special steel 4-1/2" ball bearing standard weight hinges with 3/4" offset.
- Doors over 90" in height warrant an additional hinge
- Surface mounted bottom arm with thru-bolts
- Available non-hold open (N) or selective hold open (S) at same degree as dead stop
- Built-in positive dead stop prevents door from swinging beyond the desired opening degree (85°, 90°, 95°)
- Maximum door swing 95°
- Separate and independent valves for closing speed, latch speed and backcheck
- Available with floor plate or threshold installation (floor plate shown)
- Cyclocac rustproof cement case
- Furnished with 1/2 wood and full machine screws

Optional Features

- Delayed action option – prefix "DA" (non-hold open closers only)
- Cold weather fluid option – specify "CWF" (not available for closers with "DA")
- Sealed closer option – specify "SC"
- Extended spindles available in 1/2" increments up to 2" longer than standard

Compliance

- Models available to meet ICC/ANSI A117.1 low opening force requirements, prefix "PH". (For 8-1/2 lbs. of opening force prefix "PH" and suffix "8-1/2 lbs.")
- For fire rated opening (up to 3 hour assemblies) prefix "F". This package will be supplied with 3 steel hinges and a non-hold open closer
- UL labeled closers cannot have PH option
- ANSI/C06041/C06051



TECHNICAL INFORMATION

(Frame stop required)

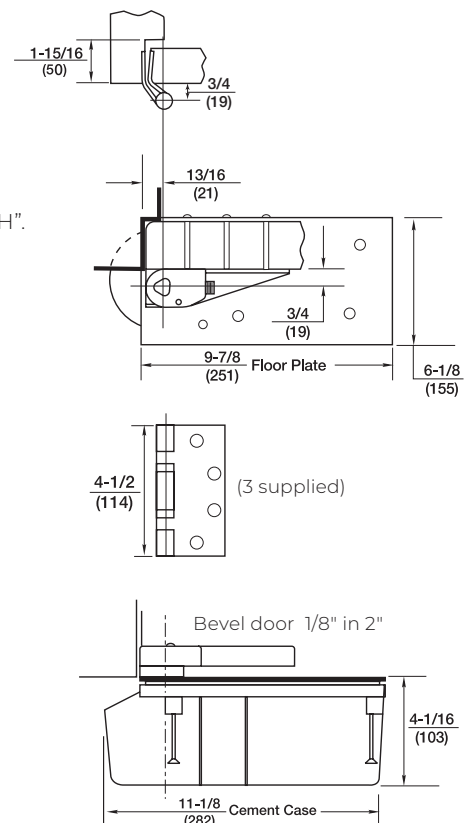

MODEL 20

Application

- Single Acting, Handed
- Interior Doors
- Weight to 200 lbs.*
- Door Width up to 3'0"

Product Description & Features

- 180 top pivot included
- M19 intermediate pivot(s) recommended (order separately)
- Allows 180° door swing (trim permitting)
- Available non-hold open only
- Single valve adjustable closing speed 70° to 0°
- Built-in hydraulic backcheck cushions opening from 140° to 180°
- Vertical door adjustment
- Available with floor plate or threshold installation (floor plate shown)
- Cast iron cement case
- Delayed action not available
- Doors 60" (1524mm) to 90" (2286mm) in height should use one intermediate pivot. Each additional 30" (762mm) warrants another intermediate pivot
- Furnished with wood and machine screws

Optional Features

- Extended spindles available in 1/2" increments up to 2" longer than standard

Compliance

- Models available to meet ICC/ANSI A117.1 low opening force requirements, prefix "PH". (For 8-1/2 lbs. of opening force prefix "PH" and suffix "8-1/2 lbs.")
- For fire rated openings (up to 3 hour assemblies) prefix F. This package will be supplied with a F180 steel top pivot and non hold open closer. FM19 intermediate pivot required (order separately)
- UL labeled closers cannot have PH option
- For 20-minute labeled doors suffix -20 to the part number
- ANSI/C06042/C06052

*Door size & weight guidelines are determined using the appropriate number of intermediate pivots



TECHNICAL INFORMATION

(Frame stop required)

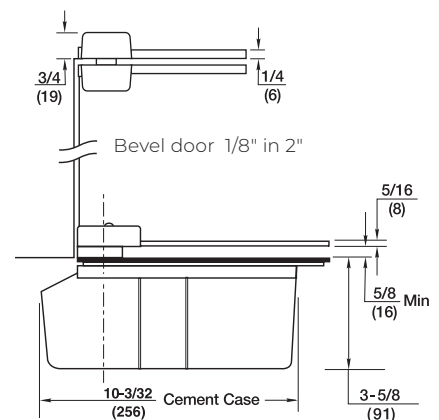
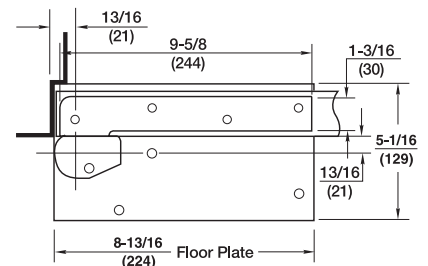
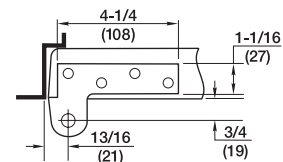

INTERMEDIATE PIVOTS

FLOOR CLOSERS

MODEL 119

Application

- Full Mortise
- Handed

Product Description & Features

- Not load-bearing
- Maintains door alignment
- Available 3/4" offset only
- Non-ferrous base material
- Recommended for use with Model 127 and 427 Floor Closers
- Bevel door 1/8" in 2"
- Furnished with wood and machine screws

Compliance

- ANSI/C07382

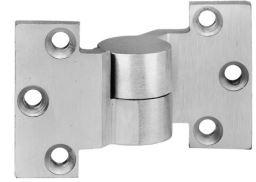

TECHNICAL INFORMATION

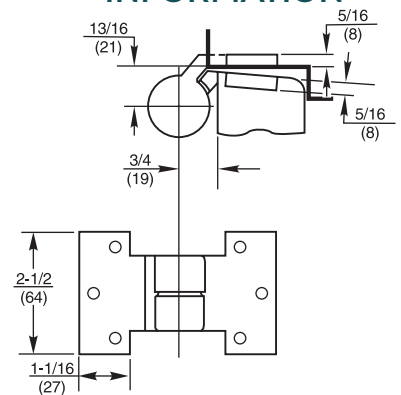

Model M19, M190

Application

- Full Mortise
- Handed

Product Description & Features

- M19, bushing, not load-bearing
- M190, bearing, load-bearing
- Maintains door alignment
- Aids in installing floor closers and bottom pivots
- Non-ferrous base material 3/4" offset standard
- Bevel door 1/8" in 2"
- For arch top doors or applications where a 180 top pivot cannot be used, supply at least two each M190 load bearing intermediate pivots, mounted together at the top of the vertical edge with a bottom pivot or floor closer
- Furnished with wood and machine screws

Optional Features

- Available 1-1/2 (38mm) offset for 3/4" cladding

Compliance

- Available for fire door assemblies (ferrous material) specify FM19 or FM190
- On labeled for fire doors NFPA80 requires an intermediate pivot for every additional 30" (762mm) of door height over 60" (1542mm)
- For 20-minute label suffix "-20" to the part number
- ANSI/C07321/C07371



TECHNICAL INFORMATION

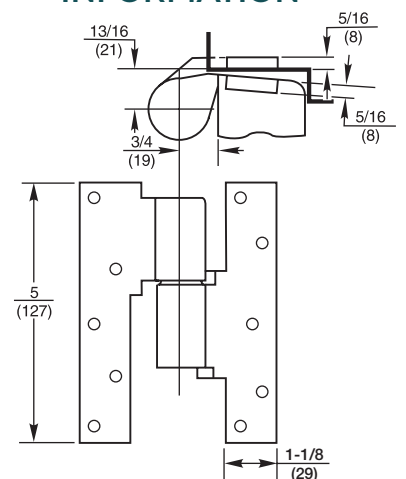

MODEL ML19

Application

- Heavy-Duty Full Mortise
- Handed

Product Description & Features

- Load-bearing
- Maintains door alignment
- Available to accommodate door thicknesses 1-3/4" (44mm), 2" (51mm), 2-1/4" (57mm), 2-1/2" (64mm), or 3" (76mm) – specify thickness when ordering
- Screw holes spaced to straddle lead lining in center of door. Use on extra heavy or high traffic doors.
- Aids in installing floor closers and bottom pivot
- Non-ferrous base material
- 3/4" offset, for extended offsets consult factory
- Bevel door 1/8" in 2"
- For arch top doors or applications where a 180 top pivot cannot be used, supply at least two each ML19 load bearing intermediate pivots, mounted together at the top of the vertical edge with a bottom pivot or floor closer
- Furnished with wood and machine screws

Compliance

- Available for fire door assemblies – 1-3/4" (44mm) door only – specify FML19
- On labeled fire door assemblies, NFPA80 requires an intermediate pivot for every additional 30" (762mm) of door height over 60" (1524mm)
- For 20-minute label suffix "-20" to part number
- ANSI/C07311



TECHNICAL INFORMATION

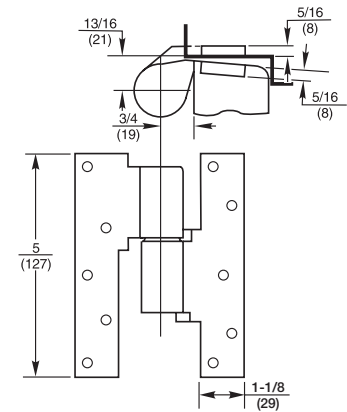

Model FA19

Application

- Full Mortise
- Handed

Product Description & Features

- Optional intermediate pivot for institutional use or installations where flat surfaces are objectionable
- Maintains door alignment
- Aids in installing bottom pivots
- Not load bearing
- 3/4" (19mm) offset
- Bevel door 1/8" in 2"
- Furnished with wood and machine Torx® screws

Compliance

- May be used with fire door assemblies
- Ferrous base material
- Doors up to 90" (2286mm) in height should use one intermediate pivot. Each additional 30" (762mm) warrants another intermediate pivot
- ANSI/C07361



TECHNICAL INFORMATION

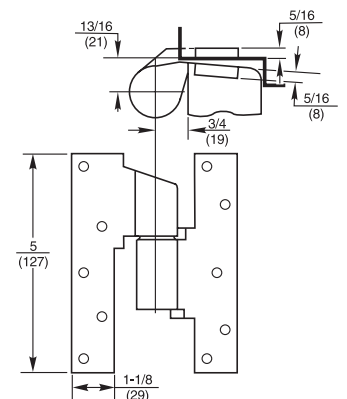

INDEPENDENTLY HUNG FLOOR CLOSERS

MODEL F327

Application

- Single Acting, Handed
- Interior or Exterior Doors
- Door Width up to 4'0" (1219mm)
- For Doors over 250 lbs. Consult Factory
- 1-3/4 doors only

Product Description & Features

- Used as a concealed floor closer for independently hung doors – butt hinges, pocket pivots, or continuous hinges
- Closer does not support weight of door
Note: Hanging means must be specified when ordering. Check the product template. If your hanging means are not listed, contact factory for a special layout and pricing
- Includes closer, mortised rail and arm with slider
- 90° maximum door swing
- Auxiliary stop recommended
- Separate and independent valves for closing speed, latch speed and backcheck
- Floor plate standard. For threshold applications a 1/2" extended spindle is required
- Cicolac rustproof cement case
- Not available in "PH", "DA", or Hold Open
- Furnished with wood and machine screws

Optional Features

- Cold weather fluid "CWF"
- Sealed closer option – specify "SC"
- Extended spindle available in 1/2" increments up to 2" longer than standard

Compliance

- This closer carries a UL Listing for 3 hour fire door assemblies. Fire rated hanging means required
- ANSI/C06031



TECHNICAL INFORMATION

(Frame stop required)

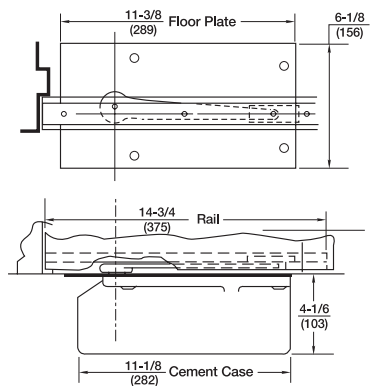

CENTER HUNG, SINGLE ACTING FLOOR CLOSERS

MODEL 28

Application

- Single Acting, Handed
- Exterior or Interior Doors
- Weight to 350 lbs.
- Centering Arm
- Sizes up to 4'0" x 8'6"* (1219 x 2591mm)

Product Description & Features

- 340 top pivot included
- Available non-hold open (N) or selective hold open (S) at same degree as dead stop
- Built-in positive dead stop prevents door from swinging beyond the desired opening degree (specify 85°, 90°, 95° or 105°)
- Centering arm with adjusting screws in face of door
- Separate and independent valves for closing speed, latch speed and backcheck
- Available with floor plate or threshold installation (floor plate shown)
- Cicolac, rustproof cement case
- Not allowed for fire rated doors
- Frame stop required on the header at the lock side. If not supplied by frame manufacturer, recommend use of 60131 (see Door Control Accessories catalog).
- Furnished with wood and machine screws

Optional Features

- Delayed action option – prefix "DA" (non-hold open closers only)
- Cold weather fluid option – specify "CWF" (not available for closers with "DA")
- Sealed closer option – specify "SC"
- Arm reinforcement bracket for wood doors - prefix W
- Extended spindles available in 1/2" increments up to 2" longer than standard

Compliance

- Models available to meet ICC/ANSI A117.1 low opening force requirements, prefix "PH". (For 8-1/2 lbs. of opening force prefix "PH" and suffix 8-1/2 lbs.)
- ANSI/C06021

* For doors taller than 8'6" use top pivot # 345 in lieu of 340



TECHNICAL INFORMATION

(Frame stop required at lock edge)

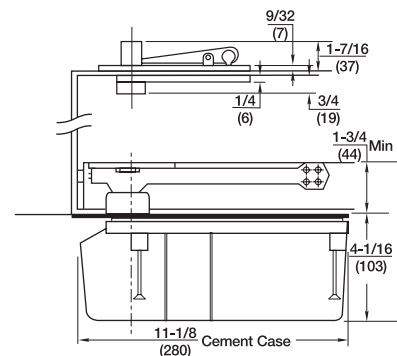
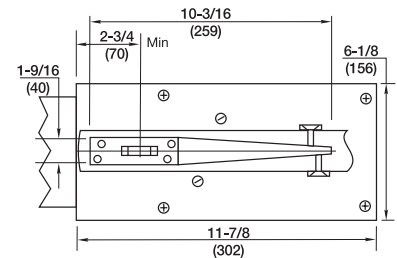

Pivot edge of door must be radiused.

CENTER HUNG, SINGLE ACTING FLOOR CLOSERS

MODEL 28 X 554 ARM

Application

- Single Acting, Handed
- Exterior or Interior Doors
- Weight to 350 lbs.
- Concealed Arm
- Sizes up to 4'0" x 8'6"* (1219 x 2591mm)

Product Description & Features

- 340 top pivot included
- Available non-hold open (N) or selective hold open (S) at same degree as dead stop
- Built-in positive dead stop prevents door from swinging beyond the desired opening degree (specify 85°, 90°, 95° or 105°)
- Concealed arm is designed to eliminate visible adjusting screws on face of door
- Arm bolt locks arm to closer spindle – adjustments made through heel of door
- Separate and independent valves for closing speed, latch speed and backcheck
- Available with floor plate or threshold installation (floor plate shown)
- Cycolac, rustproof cement case
- Not allowed for fire rated doors
- Frame stop required on the header at the lock side. If not supplied by frame manufacturer, recommend use of 60131 (see Door Control Accessories catalog).
- Furnished with wood and machine screws

Optional Features

- Delayed action option – prefix "DA" (non-hold open closers only)
- Cold weather fluid option – specify "CWF" (not available for closers with "DA")
- Sealed closer option – specify "SC"
- Extended spindles available in 1/2" increments up to 2" longer than standard

Compliance

- Models available to meet ICC/ANSI A117.1 low opening force requirements, prefix "PH". (For 8-1/2 lbs. of opening force prefix "PH" and suffix 8-1/2 lbs.)
- ANSI/C06021

* For doors taller than 8'6" use top pivot # 345 in lieu of 340



TECHNICAL INFORMATION

(Frame stop required at lock edge)

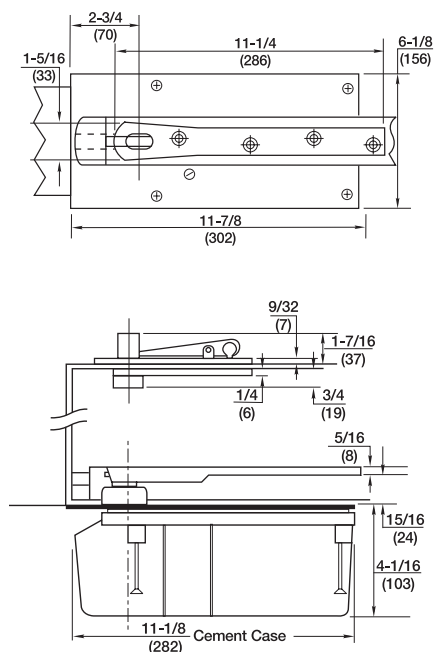

Pivot edge of door must be radiused.

CENTER HUNG, SINGLE ACTING FLOOR CLOSERS

MODEL H28

Application

- Single Acting, Handed
- Exterior or Interior Doors
- Extra Heavy High Traffic Doors
- Weight to 1000 lbs.
- Sizes up to 4'0" x 8'6"* (1219 x 2591mm)

Product Description & Features

- H340 top pivot included
- Available non-hold open (N) or selective hold open (S) at same degree as dead stop
- Built-in positive dead stop prevents door from swinging beyond the desired opening degree (specify 85°, 90°, 95° or 105°)
- For high traffic or extra heavy doors (2" min. thickness)
- Additional thrust bearing for greater load capacity
- Separate and independent valves for closing speed, latch speed and backcheck
- Available with floor plate or threshold installation (floor plate shown)
- Cast iron cement case
- Not allowed for fire rated doors
- Frame stop required at header on lock side. If not supplied by frame manufacturer, Norton Rixson 60131 recommended. Consult Door Control Accessories Catalog.
- Furnished with wood and machine screws

Optional Features

- Delayed action option – prefix "DA" (non-hold open closers only)
- Cold weather fluid option – specify "CWF" (not available for closers with "DA")
- Sealed closer option – specify "SC"
- Extended spindles available in 1/2" increments up to 2" longer than standard

Compliance

- Models available to meet ICC/ANSI A117.1 low opening force requirements, prefix "PH". (For 8-1/2 lbs. of opening force prefix "PH" and suffix "8-1/2 lbs.")
- ANSI/C06061

* For doors taller than 8'6" use top pivot H345 in lieu of H340

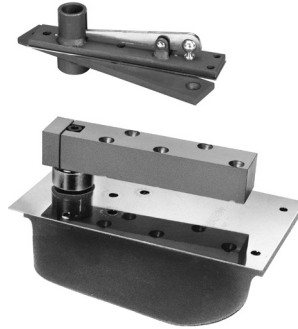

Technical Information

(Frame stop required at lock edge)

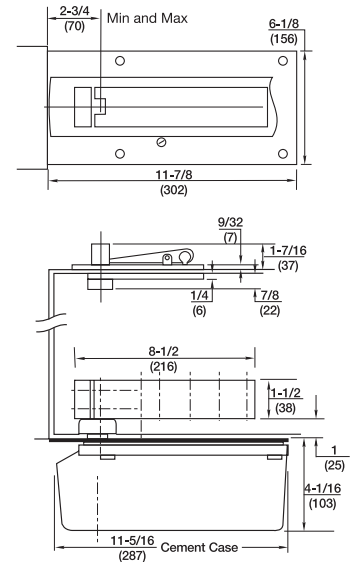

Pivot edge of door must be radiused.

MODEL H28 X 587 ARM

Product Description & Features

Identical to Model H28 except:

- Special side load arm for 1-3/4" thick doors
- Allows pivot point to be moved away from pivot edge of door minimum 2-3/4" backset

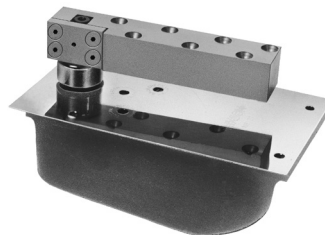

Technical Information

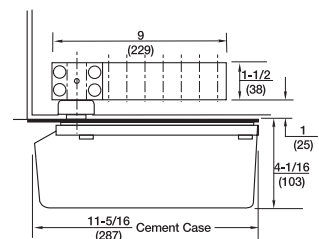

CENTER HUNG, SINGLE ACTING

FLOOR CLOSERS

MODEL 328

Application

- Single Acting, Handed
- Exterior or Interior Doors
- Glass Doors with Patch Fittings
- Weight up to 325 lbs.
- Size Up to 3'2" x 8'0"

Product Description & Features

- No arm or top pivot provided
- Patch fittings by others. Norton Rixson will provide spindle configuration to fit – provide details when ordering
- Available non-hold open (N) or selective hold open (S) at same degree as dead stop
- Built-in positive dead stop prevents door from swinging beyond the desired opening degree (specify 85°, 90°, 95° or 105°)
- Separate and independent valves for closing speed, latch speed and backcheck
- Floor plate standard. For threshold application an extended spindle is required
- Cylolac, rustproof cement case
- Not allowed for fire rated doors
- Frame stop required at header on lock side. If not supplied by frame manufacturer, Norton Rixson 60131 recommended. Consult Door Control Accessories Catalog.

Optional Features

- Delayed action option – prefix “DA” (non-hold open closers only)
- Cold weather fluid option – specify “CWF” (not available for closers with “DA”)
- Sealed closer option – specify “SC”
- For extended spindles, contact the factory

Compliance

- Models available to meet ICC/ANSI A117.1 low opening force requirements, prefix “PH”. (For 8-1/2 lbs. of opening force prefix “PH” and suffix “8-1/2 lbs.”)

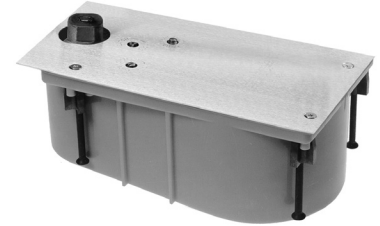

TECHNICAL INFORMATION

(Frame stop required at lock edge)

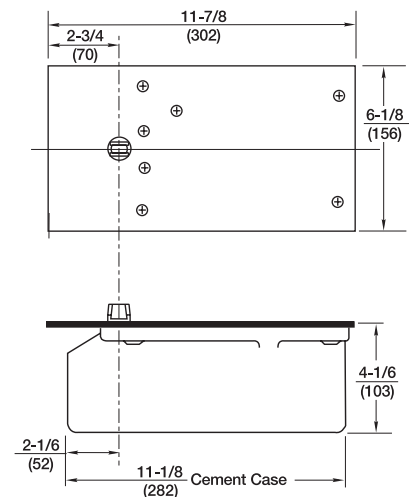

CENTER HUNG, SINGLE ACTING FLOOR CLOSERS

MODEL 428 (WITH PATCH FITTINGS)

Application

- Single Acting, Handed
- Exterior or Interior Doors
- Full Glass Doors
- Weight up to 325 lbs.
- Size Up to 3'2" x 8'0"

Product Description & Features

- Top and bottom patch fittings for tempered glass doors 3/8" - 1/2" thick
- Available non-hold open (N) or selective hold open (S) at same degree as dead stop
- Built-in positive dead stop prevents door from swinging beyond the desired opening degree (specify 85°, 90°, 95° or 105°)
- Separate and independent valves for closing speed, latch speed and backcheck
- Floor plate standard. For threshold application an extended spindle is required (floor plate shown)
- Cicolac, rustproof cement case
- Frame stop required at header on lock side
- 605, 629 and 630 finishes only

Optional Features

- Delayed action available – prefix "DA" (non-hold open closer only)
- Cold weather fluid option – specify "CWF" (not available for closers with "DA")
- Sealed closer option – specify "SC"
- For extended spindles, contact the factory. No vertical adjustment

Compliance

- Models available to meet ICC/ANSI A117.1 low opening force requirements, prefix "PH". (For 8-1/2 lbs. of opening force prefix "PH" and suffix "8-1/2 lbs.")



Technical Information

(Frame stop required at lock edge)

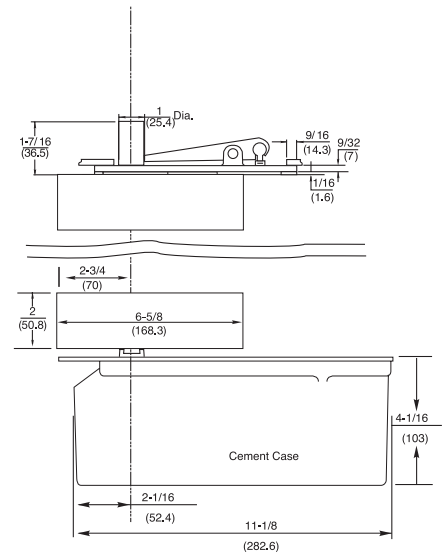

*specify finish

CENTER HUNG, SINGLE ACTING FLOOR CLOSERS

MODEL EH28

Application

- Single Acting, Handed
- Interior or Exterior Doors
- Floor Closer for Power Transfer
- Weight to 500 lbs.
- Sizes up to 4'0" x 8'6" (1219 x 2591mm)

Product Description & Features

- H340 top pivot included
- Available non-hold open (N) or selective hold open (S) at same degree as dead stop
- Built-in positive dead stop prevents door from swinging beyond the desired opening degree (specify 85°, 90°, 95° or 105°)
- Provides power transfer through closer spindle. Low voltage, Class II wiring (2 wire, 18 gauge only)
- 2" min. door thickness
- Additional thrust bearing for greater load capacity
- Separate and independent valves for closing speed, latch speed and backcheck
- Available with floor plate or threshold installation (floor plate shown)
- Cast iron cement case
- Not allowed for fire rated doors
- Frame stop required on header on lock side. If not supplied by frame manufacturer, Norton Rixson 60131 recommended. Consult Door Control Accessories Catalog.
- Furnished with wood and machine screws

Optional Features

- Delayed action option – prefix "DA"
- Cold weather fluid option – specify "CWF" (not available for closers with "DA")
- Sealed closer option – specify "SC"
- Extended spindles available in 1/2" increments up to 2" longer than standard

Compliance

- Models available to meet ICC/ANSI A117.1 low opening force requirements, prefix "PH". (For 8-1/2 lbs. of opening force prefix "PH" and suffix "8-1/2 lbs.")

* For doors taller than 8'6" use top pivot H345 in lieu of H340

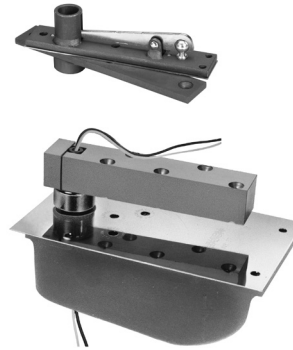

Technical Information

(Frame stop required at lock edge)

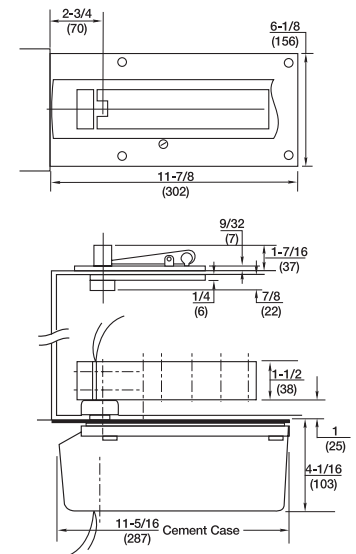

Not available with ElectroLynx®

Pivot edge of door must be radiused.

MODEL EH28 X 587 ARM

Product Description & Features

Identical to Model EH28 except:

- Special side load arm for 1-3/4" thick doors
- Allows pivot point to be moved away from pivot edge of door – minimum 2-3/4" backset

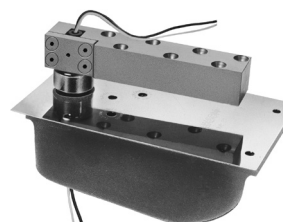

Technical Information

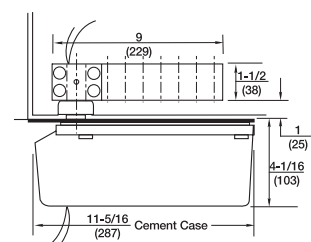

CENTER HUNG, DOUBLE ACTING FLOOR CLOSERS

MODEL 30

Application

- Double Acting, Non-handed
- Interior or Exterior[^] Doors
- Weight to 200 lbs.
- Sizes up to 4'0" x 8'6"* (1219 x 2591mm)

Product Description & Features

- 340 top pivot included
- Available non-hold open (N) or automatic hold open (A) at 90° (requires 93° swing) or 100° (requires 103° swing)
- Maximum door opening 103°
- Centering arm with adjustment screws in faces of door (critical for double acting doors)
- Adjustable closing speed valves for each direction of door swing
- Mechanism returns door to center
- Auxiliary door stop required, overhead or floor type
- Available with floor plate or threshold installation (floor plate shown)
- Steel cement case
- Not available in Delayed Action (DA)
- Not allowed for fire rated doors
- Furnished with wood and machine screws

Optional Features

- Cold weather fluid option – specify "CWF"
- Sealed closer option – specify "SC"
- Arm reinforcement bracket for wood doors – prefix "W"
- Extended spindles available in 1/2" increments up to 2" longer than standard

Compliance

- ANSI/C06012

* For doors taller than 8'6" use top pivot 345 in lieu of 340

[^]Primary means of egress should not use double-acting closers



Technical Information

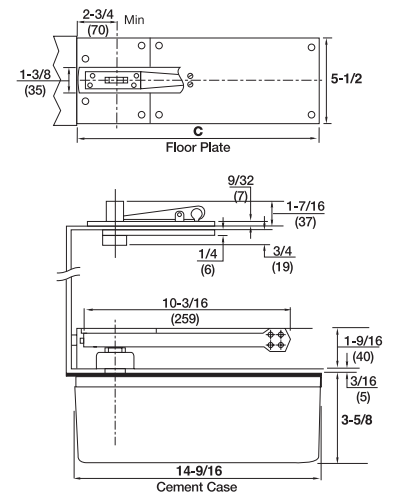

Pivot edge of door
must be radiused.

CENTER HUNG, DOUBLE ACTING FLOOR CLOSERS

MODEL 40

Application

- Double Acting, Non-handed
- Interior or Exterior[^] Doors
- Weight to 300 lbs.
- Sizes up to 4'0" x 8'6"* (1219 x 2591mm)

Product Description & Features

- 340 top pivot included
- Available non-hold open (N) or automatic hold open (A) at 90° (requires 93° swing) or 100° (requires 103° swing)
- Maximum door opening 103°
- Centering arm with adjustment screws in faces of door (critical for double acting doors)
- Adjustable closing speed valves for each direction of door swing
- Mechanism returns door to center
- Auxiliary door stop required, overhead or floor type
- Available with floor plate or threshold installation (floor plate shown)
- Steel cement case
- Not available in Delayed Action (DA)
- Not allowed for fire rated doors
- Furnished with wood and machine screws

Optional Features

- Cold weather fluid option – specify “CWF”
- Sealed closer option – specify “SC”
- Arm reinforcement bracket for wood doors – prefix “W”
- Extended spindles available in 1/2" increments up to 2" longer than standard

Compliance

- Models available to meet ICC/ANSI A117.1 low opening force requirements, prefix “PH”. (For 8-1/2 lbs. of opening force prefix PH and suffix 8-1/2 lbs.)
- ANSI/C06012

* For doors taller than 8'6" use top pivot 345 in lieu of 340

[^] Primary means of egress should not use double-acting closers



Technical Information

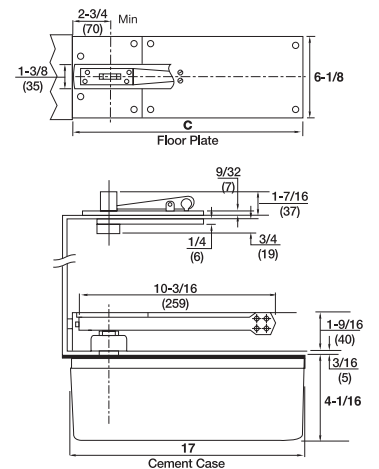

Pivot edge of door must be radiused.

CENTER HUNG, DOUBLE ACTING FLOOR CLOSERS

MODEL H40

Application

- Double Acting, Non-handed
- Interior or Exterior[^] Doors
- Weight to 1000 lbs.
- Sizes up to 4'0" x 8'6"* (1219 x 2591mm)

Product Description & Features

- H340 top pivot included
- Available non-hold open (N) or automatic hold open (A) at 90° (requires 93° swing) or 100° (requires 103° swing)
- Maximum door opening 103°
- For thick, extra heavy doors (2" min. thickness)
- Thrust bearing for greater load capacity
- Adjustable closing speed valves for each direction of door swing
- Mechanism returns door to center
- Available with floor plate or threshold installation (floor plate shown)
- Steel cement case
- Auxiliary door stop required, overhead or floor type
- This arm does not allow door centering adjustment. Not recommended for pairs of doors
- Not allowed for fire rated doors
- Furnished with wood and machine screws

Optional Features

- Cold weather fluid option – specify "CWF"
- Sealed closer option – specify "SC"
- Extended spindles available in 1/2" increments up to 2" longer than standard

Compliance

- Models available to meet ICC/ANSI A117.1 low opening force requirements, prefix "PH". (For 8-1/2 lbs. of opening force prefix PH and suffix 8-1/2 lbs.)
- ANSI/C06012

* For doors taller than 8'6" use to pivot H345 in lieu of H340

[^] Primary means of egress should not use double-acting closers

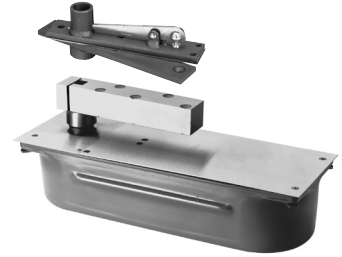

Technical Information

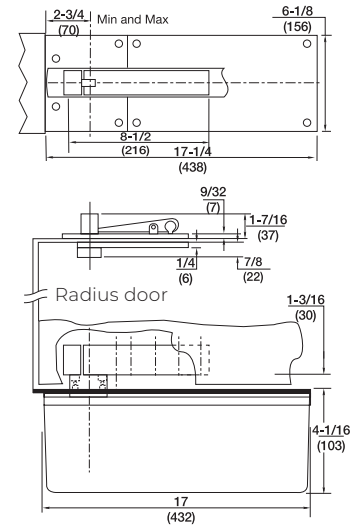

Pivot edge of door must be radiused.

MODEL H40 X 587 ARM

Product Description & Features

Identical to Model H40 except:

- Special side load arm for 1-3/4" thick doors
- Allows pivot point to be moved away from pivot edge of door. Minimum 2-3/4" backset

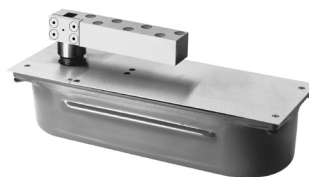

Technical Information

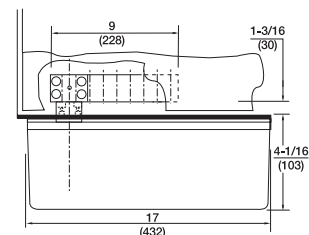

OPTIONAL CENTER HUNG TOP PIVOTS

FLOOR CLOSERS

345 TOP PIVOT

Application

- Fully Concealed
- Center Hung
- Non-handed
- Earthquake Tolerant
- Taller Doors

Product Description & Features

- Ideal for locations where dramatic building settling is possible. Also, for doors over 8'6" in height
- Long pivot pin engages in top of door 1-3/4" (44mm).
- Can be used with any center hung floor closer. Order the floor closer LTP (less top pivot) and the 345 top pivot separately
- Walking beam-type pivot – 1/2" (13mm) diameter pivot pin
- Oil impregnated sintered bronze bearing
- Completely concealed when door is closed
- Furnished with wood and machine screws

Compliance

- ANSI/C07021

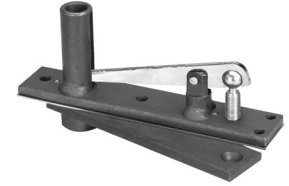

Technical Information

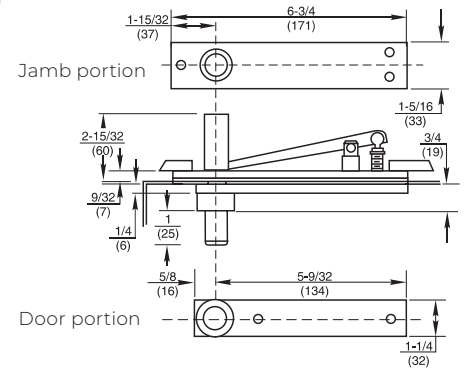

H345 TOP PIVOT

Application

- Fully Concealed
- Center Hung
- Non-handed
- Earthquake Tolerant
- Taller Doors

Product Description & Features

- Ideal for locations where dramatic building settling is possible or for doors over 8'6" in height
- Long pivot pin engages in top of door 1-3/4" (44mm)
- Can be used with heavy-duty (H) center hung floor closer. Order the floor closer LTP (less top pivot) and the H345 top pivot separately
- Walking beam-type pivot – 11/16" (18mm) diameter pivot pin
- Heavy-duty needle bearing
- Completely concealed when door is closed
- Furnished with wood and machine screws

Compliance

- ANSI/C07011



Technical Information

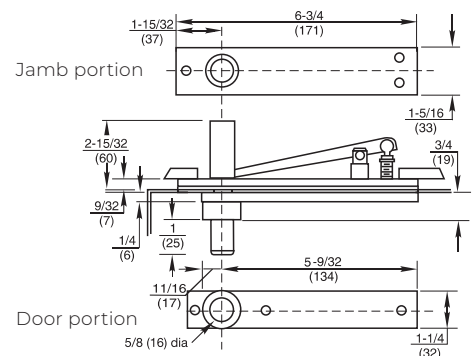

HOW TO ORDER

FLOOR CLOSERS

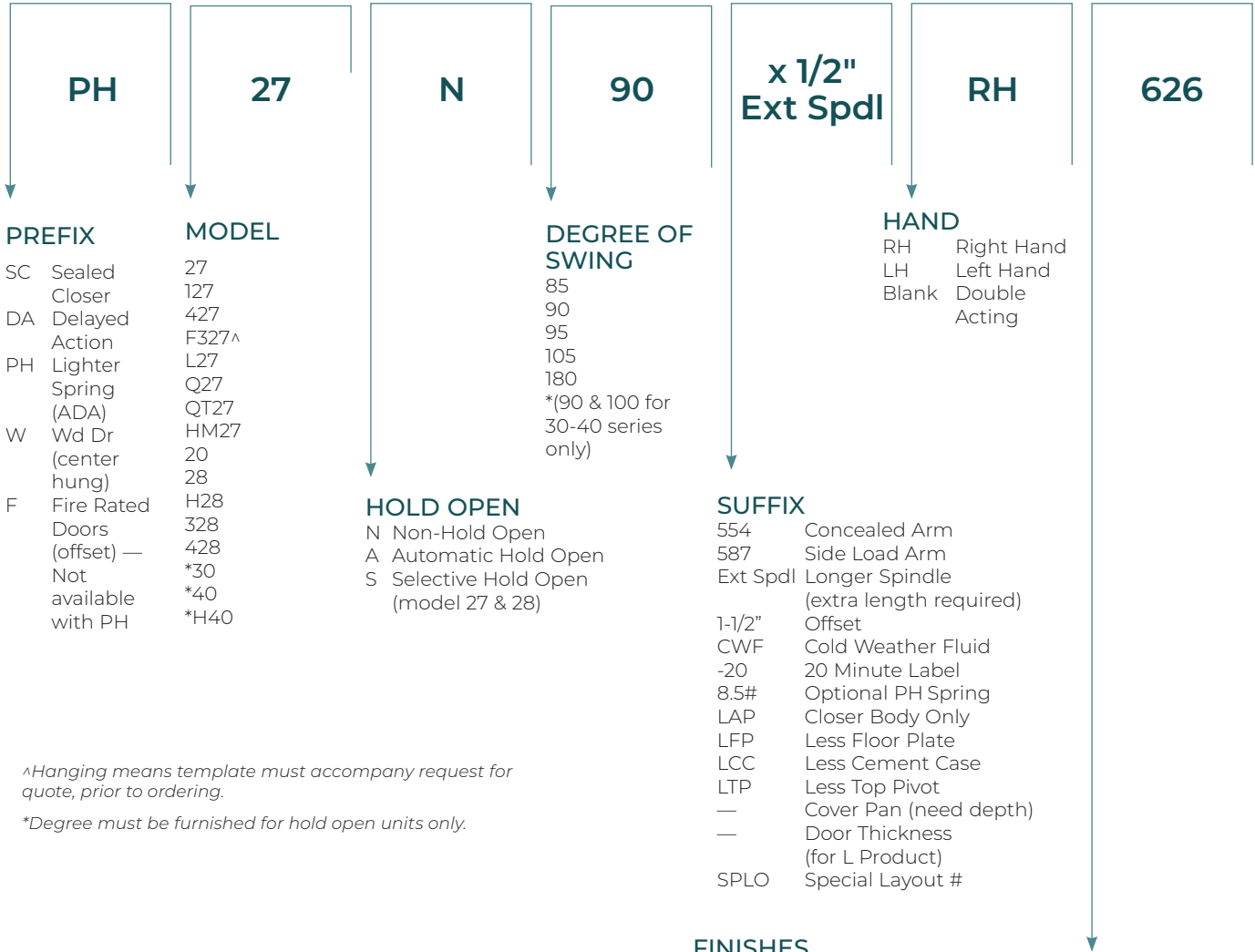

PREFIX

- SC Sealed Closer
- DA Delayed Action
- PH Lighter Spring (ADA)
- W Wd Dr (center hung)
- F Fire Rated Doors (offset) — Not available with PH

MODEL

- 27
- 127
- 427
- F327^
- L27
- Q27
- QT27
- HM27
- 20
- 28
- H28
- 328
- 428
- *30
- *40
- *H40

N

HOLD OPEN

- N Non-Hold Open
- A Automatic Hold Open
- S Selective Hold Open (model 27 & 28)

90

DEGREE OF SWING

- 85
- 90
- 95
- 105
- 180
- *(90 & 100 for 30-40 series only)

x 1/2" Ext Spdl

SUFFIX

- 554 Concealed Arm
- 587 Side Load Arm
- Ext Spdl Longer Spindle (extra length required)
- 1-1/2" Offset
- CWF Cold Weather Fluid
- 20 20 Minute Label
- 8.5# Optional PH Spring
- LAP Closer Body Only
- LFP Less Floor Plate
- LCC Less Cement Case
- LTP Less Top Pivot
- Cover Pan (need depth)
- Door Thickness (for L Product)
- SPLO Special Layout #

RH

HAND

- RH Right Hand
- LH Left Hand
- Blank Double Acting

626

FINISHES

Description	Specify Norton Rixson Designation (BHMA)
605	Bright Brass
606	Satin Brass
611	Bright Bronze
612	Satin Bronze
613	Antique Bronze
613E	Dark Oxidized Satin Bronze - equivalent
618	Bright Nickel
619	Satin Nickel
622	Flat Black
625	Bright Chrome
626	Satin Chrome
BSP	Black Suede Powder
WSP	White Suede Powder

^Hanging means template must accompany request for quote, prior to ordering.

*Degree must be furnished for hold open units only.

PRODUCT COMPARISON CHART

FLOOR CLOSERS

OFFSET HUNG

	20	27	27-180	127	427	HM27 ⁶	L27	L27-180	Q27, QT27 ⁷
Application	Replacement	Standard	Standard	Deep reveal	Deep reveal or alcove	Hollow metal doors and frames	Lead-lined, heavy or high traffic	Lead-lined, heavy or high traffic	Arm allows closer to be removed without demounting door
3/4" offset standard	•	•	•	•	•	•	•	•	•
1-1/2" offset optional ¹		•	•				consult factory	consult factory	
Handed	•	•	•	•	•	•	•	•	•
Exterior door		•	•	•	•	•	•	•	•
Interior door	•	•	•	•	•	•	•	•	•
Non-hold open	•	•	•	•	•	•	•	•	•
Selective hold open		•		•	•	•	•		•
Automatic hold open			•					•	
Door weight	200 lbs.	450 lbs.	450 lbs.	250 lbs.	250 lbs.	250 lbs.	1500 lbs.	1500 lbs.	350 lbs.
Maximum door swing ²	180°	105°	180°	105°	105°	95°	105°	180°	95°
Maximum door width	36"	48"	48"	48"	48"	48"	48"	48"	48"
Standard top pivot (included)	180	180	180	180	180x102	N/A	L180	L180	180
Intermediate pivot (order separately) ³	M19	M19	M19	119	119	N/A	ML19	ML19	(1) M19 included
Standard 1-3/4" door thickness	•	•	•	•	•	•	•	•	•
Optional door thicknesses available ⁴							•	•	
Extended spindles available ⁵	•	•	•	•	•	•	•	•	•
Options	PH, F, -20	SC, DA, PH, F, CWF, -20	SC, PH, F, CWF, -20	SC, DA, PH, F, CWF, -20	SC, DA, PH, CWF	SC, DA, PH, F, CWF, -20	SC, DA, PH, F, CWF, -20	SC, PH, F, -20	SC, DA, PH, F, CWF, -20
Furnished with wood and machine screws	•	•	•		•	•	•	•	•

Note: All offset closers have positive deadstop except models F327 and 20

1. Recommended door weight will be less when 1-1/2" offset is specified
2. Door swing must be specified when ordering several models. Models 27, 127, 427 and L27; specify 85°, 90°, 95° or 105°. Q/QT models; specify 85°, 90° or 95°
3. Doors 60" (1524mm) to 90" (2286mm) in height should use one intermediate pivot. Each additional 30" (762mm) of door height warrants another intermediate pivot
4. Can accommodate the following door thicknesses: 2", 2-1/4", 2-1/2" or 3". Specify when ordering
5. 1/2" increments up to 2"
6. Shipped with (3) special hinges
7. Q: includes floor plate, QT: for threshold applications
8. Delayed Action only available with NHO closers
9. CWF not available for closers with DA

Optional Features	Designation
Sealed Closer	SC
Delayed Action ⁸	DA
Physically Handicapped	PH
Fire Rated	F
Cold Weather Fluid ⁹	CWF
20 minute label	-20

CENTER HUNG, SINGLE ACTING

	28	28x554	328	428	EH28 ³	EH28x587 ^{3,4}	H28	H28x587 ⁴
Application	Standard	Standard; concealed arm eliminates visible adjusting screws	Glass doors with patch fittings (by others)	Full glass doors with patch fitting (by others)	Floor closer for power transfer through closer spindle	Floor closer for power transfer through closer spindle; side load arm	Extra Heavy, High Traffic Doors	Extra Heavy, High Traffic Doors; side load arm
Handed	•	•	•	•	•	•	•	•
Exterior door	•	•	•	•	•	•	•	•
Interior door	•	•	•	•	•	•	•	•
Non-hold open	•	•	•	•	•	•	•	•
Selective hold open	•	•	•	•	•	•	•	•
Door weight	350 lbs.	350 lbs.	325 lbs.	325 lbs.	500 lbs.	500 lbs.	1000 lbs.	1000 lbs.
Maximum door swing ¹	105°	105°	105°	105°	105°	105°	105°	105°
Maximum door width	48"	48"	38"	38"	48"	48"	48"	48"
Standard top pivot (included)	340	340	N/A	Special to fit patch fitting	H340	H340	H340	H340
Standard door thickness	1-3/4"	1-3/4"	N/A	3/8" - 1/2" thick tempered glass doors	2"	1-3/4"	2"	1-3/4"
Frame stop required	•	•	•	•	•	•	•	•
Extended spindles available ²	•	•	Consult factory	Consult factory	•	•	•	•
Optional Features	SC, DA, PH, W, CWF	SC, DA, PH, CWF	SC, DA, PH, CWF	SC, DA, PH, CWF	SC, DA, PH, CWF	SC, DA, PH, CWF	SC, DA, PH, CWF	SC, DA, PH, CWF
Furnished with wood and machine screws	•	•	•	•	•	•	•	•

Notes:

- Center hung closers are not allowed on fire rated doors
- Doors taller than 8'6", use 345 in lieu of 340 top pivot and H345 in lieu of H340 top pivot
- All single acting closers have positive deadstop

1. Door swing must be specified when ordering center hung single acting closers. Single acting closers: specify 85°, 90°, 95° or 105°

2. 1/2" increments up to 2"

3. Low voltage Class II wiring (2 wire, 18 gauge only)

4. Side load arm allows pivot point to be moved away from pivot edge of door; minimum 2-3/4" backset

5. Delayed Action only available with NHO closers

6. Cold Weather Fluid not available for closers with Delayed Action

Optional Features	Designation
Sealed Closer	SC
Delayed Action ⁵	DA
Physically Handicapped	PH
Wood Door	W
Cold Weather Fluid ⁶	CWF

PRODUCT COMPARISON CHART

FLOOR CLOSERS

CENTER HUNG, DOUBLE ACTING

	30	40	H40 ³	H40x587 ⁴
Application	Standard	Standard	Extra Heavy, High Traffic Doors	Extra Heavy, High Traffic Doors; Side Load Arm
Exterior door	•	•	•	•
Interior door	•	•	•	•
Non-hold open	•	•	•	•
Automatic hold open	•	•	•	•
Door weight	200 lbs.	300 lbs.	1000 lbs.	1000 lbs.
Maximum door swing ¹	103°	103°	103°	103°
Maximum door width	48"	48"	48"	48"
Standard top pivot (included)	340	340	H340	H340
Standard 1-3/4" door thickness	•	•	2" (min)	•
Extended spindles available ²	•	•	•	•
Optional Features	SC, PH, W, CWF	SC, PH, W, CWF	SC, PH, CWF	SC, PH, CWF
Furnished with wood and machine screws	•	•	•	•

Notes:

- Center hung closers are not allowed on fire rated doors
 - Primary means of egress should NOT use double acting closers
 - Doors taller than 8'6", use 345 in lieu of 340 top pivot and H345 in lieu of H340 top pivot
1. Door swing must be specified when ordering closers. Specify 90° or 100°. Door will swing 3° beyond specified degree.
 2. 1/2" increments up to 2"
 3. Arm does not allow centering adjustment; NOT recommended for pair of doors
 4. Side load arm allows pivot point to be moved away from pivot edge of door; minimum 2-3/4" backset
 5. CWF not available for closers with DA

Optional Features	Designation
Sealed Closer	SC
Physically Handicapped	PH
Wood Door	W
Cold Weather Fluid ⁵	CWF

MODEL 27

RIGHT HAND SHOWN
3/4" OFFSET

- (A) Pivot Stud
181770-ASY
- (B) Hex Cap
181778-*
- (C) Arm Cap & Screw
012142R*AS (RH, BRS)
012142L*AS (LH, BRS)
012144R*AS (RH, SS)
012144L*AS (LH, SS)
- (D) 3/4" Offset Arm x Locking
Screw
275177 (RH)
275176 (LH)
- (E) Arm Locking Screw Only
88905-PKG (5)
- (F) Arm Shims
275065-PKG (5)
- (G) Arm Bearing Washer
275062-PKG (5)
- (H) Spindle Shoulder Collar
259000-*
- (I) Floor Plate x Screws
274050R* (RH) NHO
274050L* (LH) NHO
274750R* (RH) SHO
274750L* (LH) SHO
- (J) Closer Body
LAP Specify Complete
Model
- (K) Cement Case x Screws
253000-PKG
- (L) 3/4" Offset Top Pivot
Assembly
180 (standard)
F180 (Fire Rated)
180-20 (20 minutes)
- (M) Bottom Arm Package
252050R* (RH)
252050L* (LH)
(Includes C,D, H, and
attaching screws)

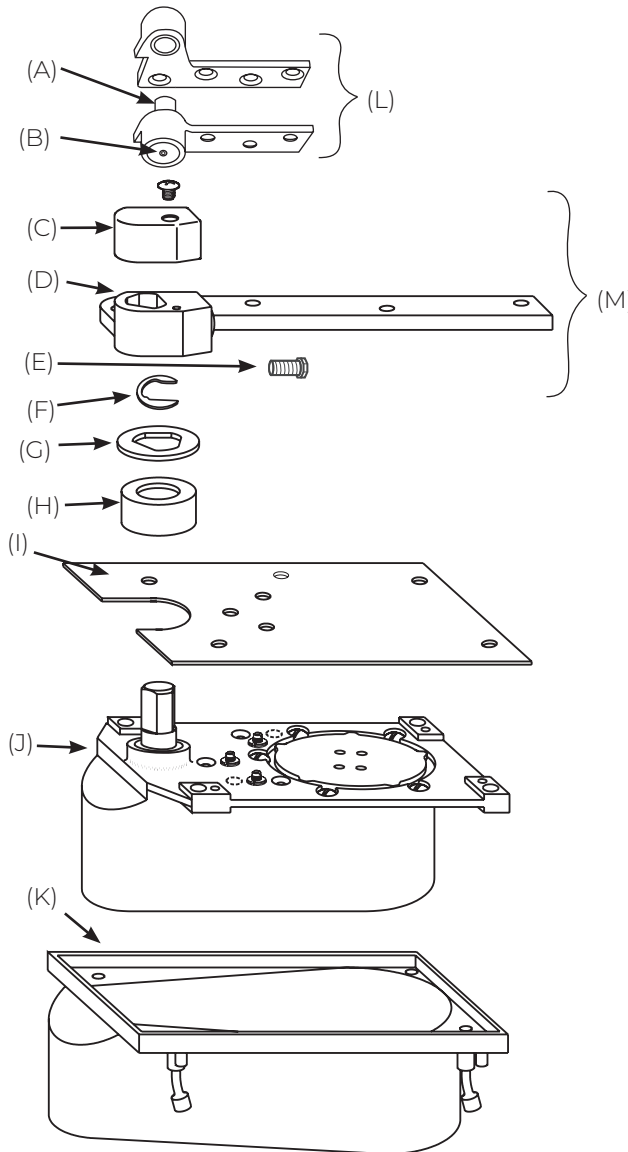

SCREW KITS

180 Top Pivot Screw Kit
107014-* Machine (2) Req
107114-* Wood (2) Req

Arm Screw Kit
107044 Machine
107144 Wood

Floor Plate Screw Kit
107004 -*

Cement Case Screw Kit
107046

FOR 27 x 1-1/2" OFFSET

1-1/2" Offset Top Pivot
180 x 1-1/2" (standard)
F180 x 1-1/2" (Fire Rated)
180 x 20 x 1-1/2" (20 minute)

1-1/2" Offset Arm x Locking Screw
275167-*

1-1/2" Bottom Arm Package
252060R*
252060L*

PARTS DRAWINGS

FLOOR CLOSERS

MODEL 127/427

RIGHT HAND SHOWN
3/4" OFFSET

- (A) Pivot Stud
181770-ASY
- (B) Hex Cap
181778-*
- (C) Arm Cap x Screw
12029-AS
- (D) 3/4" Offset Arm
12027 (RH)
12028 (LH)
- (E) Spindle Shoulder Collar
259000-*
- (F) Floor Plate with Screws
274050R* (RH) NHO
274050L* (LH) NHO
274750R* (RH) SHO
274750L* (LH) SHO
- (G) Closer Body (Specify
Complete Model
No. x LAP)
- (H) Cement Case with
Screws
253000 - PKG
- (I) 3/4" Offset Top Pivot
180 (standard)
F180 (Fire Rated)
180 x 20 (20 Minute)
- (J) Bottom Arm Package
652050R* (RH)
652050L* (LH)
(Includes C, D and
attaching screws)

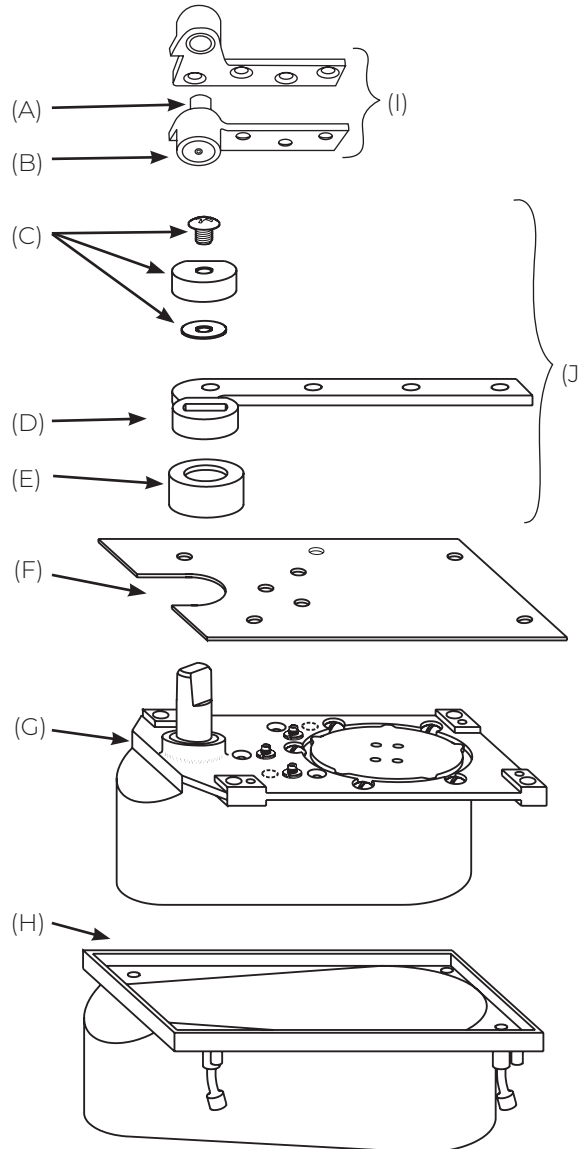

SCREW KITS

180 x 102 Screw Kit
107014-* 1 each Machine
107114-* 1 each Wood
107112-* 1 each Wood
107012-* 1 each Machine

180 Top Pivot Screw Kit
107014-* Machine (2) Req
107114-* Wood (2) Req

Arm Screw Kit
107044 Machine
107144 Wood

Floor Plate Screw Kit
107004-*

Cement Case Screw Kit
107046

MODEL 427

(D) 3/4" Offset Arm
12027 (RH)
12028 (LH)

Top Pivot
180 x 102

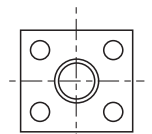

180 x 102

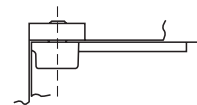

*specify finish

MODEL L27

RIGHT HAND SHOWN
3/4" OFFSET

- (A) Pivot Stud
181770-ASY
- (B) Hex Cap
181778-*
- (C) Arm Cap & Screw
012142R*AS (RH, BRS)
012142L*AS (LH, BRS)
012144R*AS (RH, SS)
012144L*AS (LH, SS)
- (D) Arm x Locking Screw
1-3/4" Door
18550-Asy (RH)
18650-Asy (LH)

2" Door
18551-Asy (RH)
18651-Asy (LH)

2-1/4" Door
18552-Asy (RH)
18652-Asy (LH)

2-1/2" Door
18553-Asy (RH)
18653-Asy (LH)

3" Door
18554-Asy (RH)
18654-Asy (LH)
- (E) Arm Locking Screw Only
88905-PKG (5)
- (F) Spindle Shoulder Collar
259500-*
- (G) Heavy-Duty Thrust Bearing
41204-PKG
(Includes 41207N spacer)
- (H) Floor Plate with Screws
274050R* (RH) NHO
274050L* (LH) NHO
274750R* (RH) SHO
274750L* (LH) SHO
- (I) Closer Body
(Specify Complete
Model No. x LAP)
(Includes G)
- (J) Cement Case with
Screws 253001-PKG

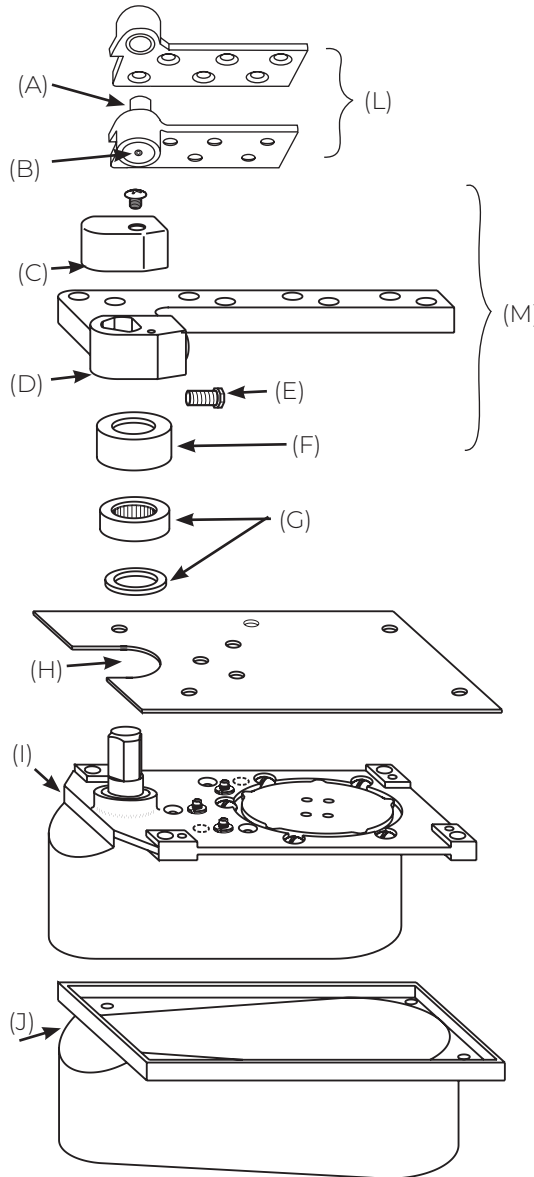

- (L) 3/4" Offset Top Pivot
L180 (standard)
FL180 (Fire Rated)
L180 x 20 (20 minute)
- (M) Bottom Arm Package
1-3/4" Door
252051R*(RH)
252051L* (LH)

2" Door
252052R* (RH)
252052L* (LH)

2-1/4" Door
252053R* (RH)
252053L* (LH)

2-1/2" Door
252054R* (RH)
252054L* (LH)

3" Door
252055R* (RH)
252055L* (LH)
(Includes: C, D, F and
attaching screws)

SCREW KITS

- L180 Screw Kit
107016-* Machine (2) Req
107116-* Wood (2) Req
- Arm Screw Kit
107048 Machine (2) Req
107144 Wood (2) Req
- Floor Plate Screw Kit
107004-*
- Cement Case Screw Kit
107046

*specify finish

PARTS DRAWINGS

FLOOR CLOSERS

MODEL Q27/QT27

**RIGHT HAND SHOWN
3/4" OFFSET ONLY**

- (A) Pivot Stud
181770-ASY
- (B) Hex Cap
181778-*
- (C) Arm Cap & Screw
73035R*AS (RH)
73035L*AS (LH)
- (D) Arm Mounting Screws
and Plate
73014-*
- (E) Removable Arm
73001R-ASY (RH)
73001L-ASY (LH)
- (F) Arm Locking Screw
Only
88905-PKG (5)
- (G) Arm Washer/Shim
Package - 275179
(Includes 275065 and
275178 Torque Washer)
- (H) Q Floor Plate with
Screws
294050R* (RH) (NHO)
294050L* (LH) (NHO)
294750R* (RH) (SHO)
294750L* (LH) (SHO)
- (I) Q27 Styrofoam Filler
73009
- (J) Closer Body
(Specify Complete
Model No. x LAP)
- (K) Cement Case with
Screws 253000-PKG
- (P) QT Styrofoam Filler
73017
- (R) Spindle Shoulder Collar
259000-*

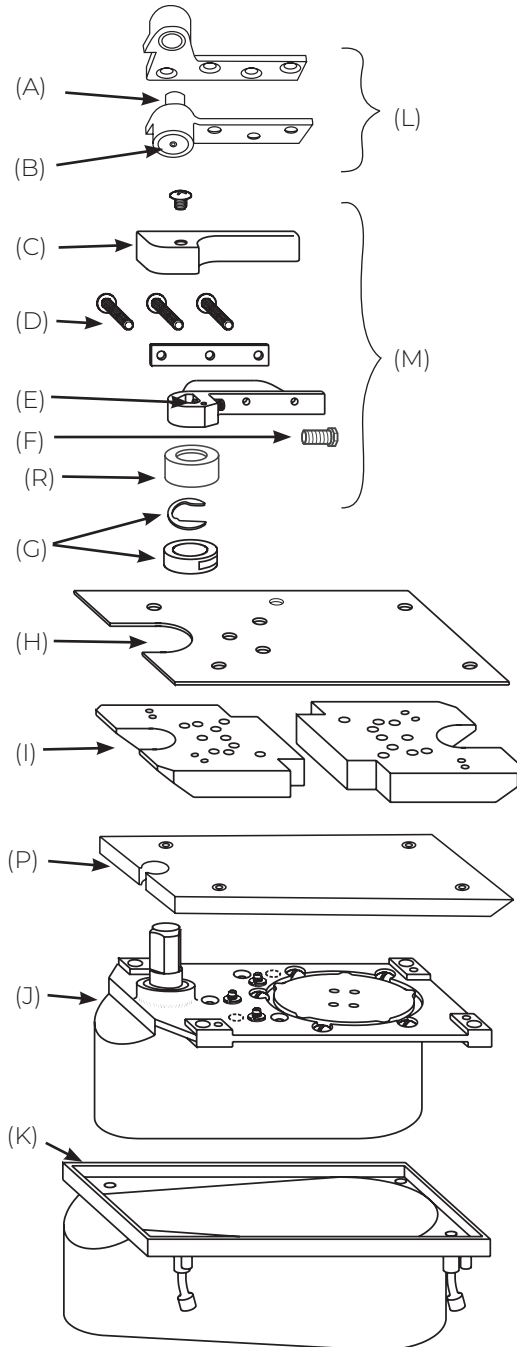

- (L) 3/4" Offset Top Pivot
180 (standard)
F180 (Fire Rated)
180 x 20 (20 minute)
- (M) Bottom Arm Package
222050R* (RH)
222050L* (LH)
(Includes C, D, E, R and
attaching screws)
- (N) 3/4" Offset Intermediate Pivot
M19 (standard)
FM19 (Fire Rated)
M19-20 (20 minute)

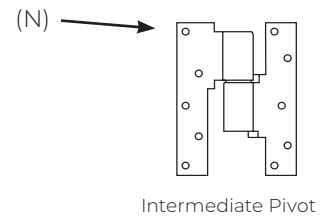

SCREW KITS

- 180 Screw Kit
107014-* Machine (2) Req
107114-* Wood (2) Req

- Q Floor Plate Screw Kit
107010-*

- Cement Case Screw Kit
107046

- M19 Intermediate Pivot Screw Kit
107015-* Machine (2) Req
107115-* Wood (2) Req

*specify finish

MODEL HM27

RIGHT HAND SHOWN
3/4" OFFSET

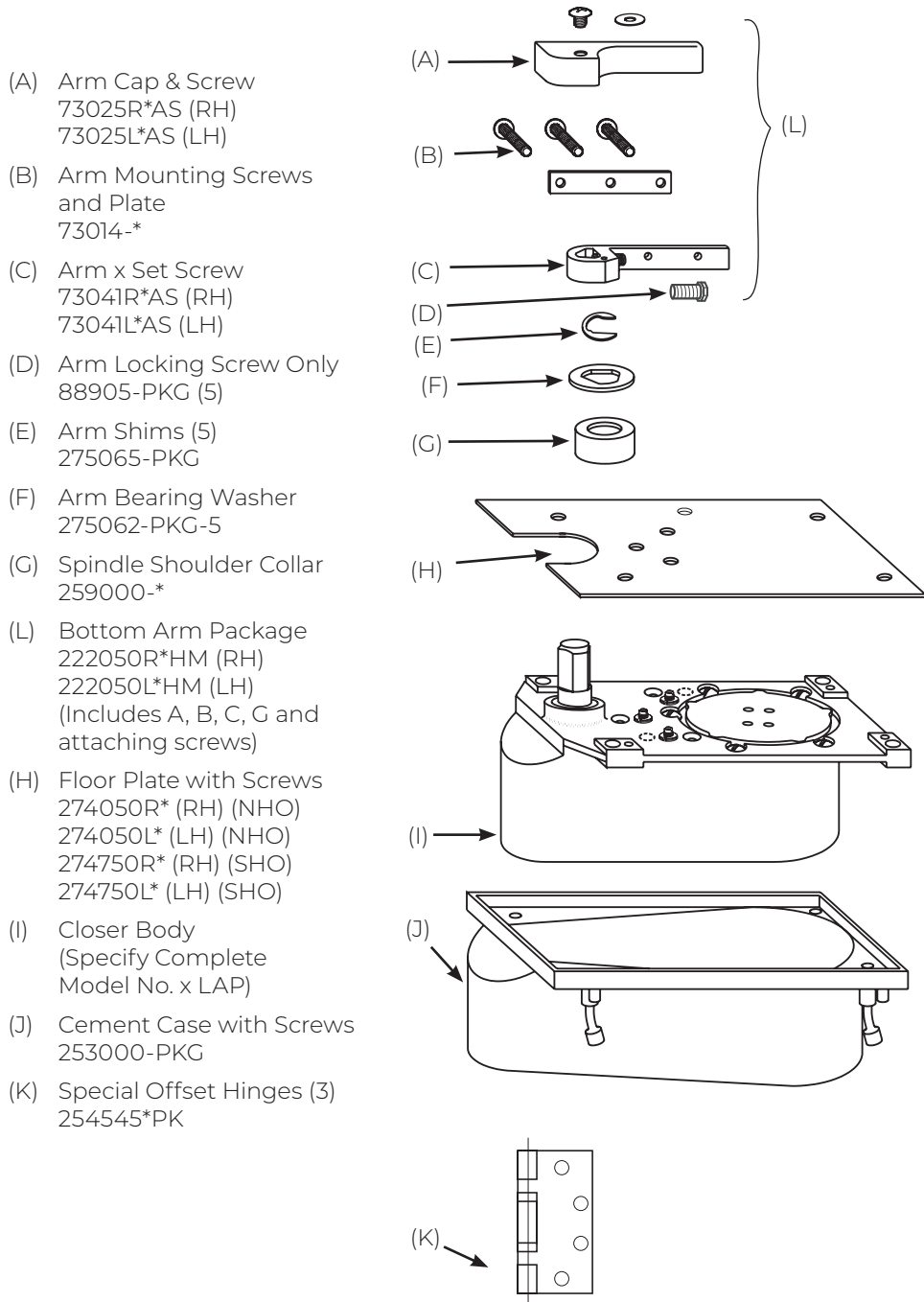

- (A) Arm Cap & Screw
73025R*AS (RH)
73025L*AS (LH)
- (B) Arm Mounting Screws
and Plate
73014-*
- (C) Arm x Set Screw
73041R*AS (RH)
73041L*AS (LH)
- (D) Arm Locking Screw Only
88905-PKG (5)
- (E) Arm Shims (5)
275065-PKG
- (F) Arm Bearing Washer
275062-PKG-5
- (G) Spindle Shoulder Collar
259000-*
- (L) Bottom Arm Package
222050R*HM (RH)
222050L*HM (LH)
(Includes A, B, C, G and
attaching screws)
- (H) Floor Plate with Screws
274050R* (RH) (NHO)
274050L* (LH) (NHO)
274750R* (RH) (SHO)
274750L* (LH) (SHO)
- (I) Closer Body
(Specify Complete
Model No. x LAP)
- (J) Cement Case with Screws
253000-PKG
- (K) Special Offset Hinges (3)
254545*PK

SCREW KITS

Floor Plate Screw Kit
107004-*

Cement Case Screw Kit
107046

Hinge Screw Kit
107519-*

*specify finish

PARTS DRAWINGS

FLOOR CLOSERS

MODEL 20

RIGHT HAND SHOWN
3/4" OFFSET

- (A) Pivot Stud
181770-ASY
- (B) Hex Cap
181778-*
- (C) Arm Cap & Screw
012142R*AS
(RH, BRS)
012142L*AS
(LH, BRS)
012144R*AS
(RH, SS)
012144L*AS
(LH, SS)
- (D) 3/4" Offset Arm x
Locking Screw
275177 (RH)
275176 (LH)
- (E) Arm Locking Screw Only
88905-PKG (5)
- (F) Arm Shims
275065-PKG (5)
- (G) Arm Bearing Washer
275062-PKG (5)
- (H) Spindle Shoulder Collar
259000-*
- (L) 3/4" Offset Top Pivot
180 (standard)
FL180 (Fire Rated)
180 - 20 (20 Minute)
- (M) Bottom Arm Package
252050R* (RH)
252050L* (LH)
(Includes C, D, H and
attaching screws)
- (I) Floor Plate with Screws
204050-*
- (J) Closer Body (Specify
Complete Model No. x LAP)
- (K) Cement Case with Screws
203000

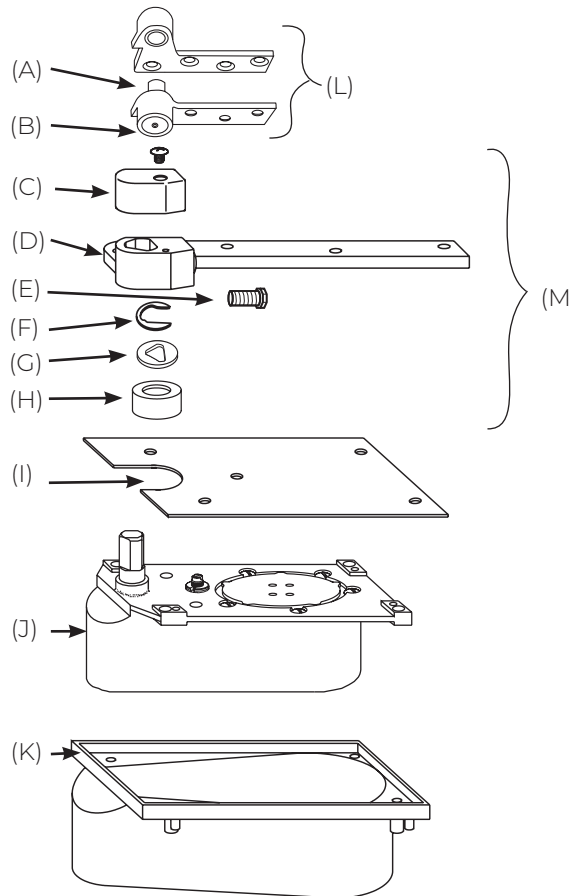

SCREW KITS

- 180 Screw Kit
- 107014-* Machine (2) Req
- 107114-* Wood (2) Req
- Arm Screw Kit
- 107044-* Machine (2) Req
- 107144-* Wood (2) Req
- Floor Plate Screw Kit
- 107004-*
- Cement Case Screw Kit
- 107046

*specify finish

MODEL F327

**RIGHT HAND SHOWN
INDEPENDENTLY HUNG**

- (A) Door Rail
327006
- (B) Bottom Arm Package
3252010-*
- (C) Floor Plate with Screws
3274010R* (RH)
3274010L* (LH)
- (D) Closer Body
(Specify Complete
Model No. x LAP)
- (E) Cement Case with
Screws
253000-PKG

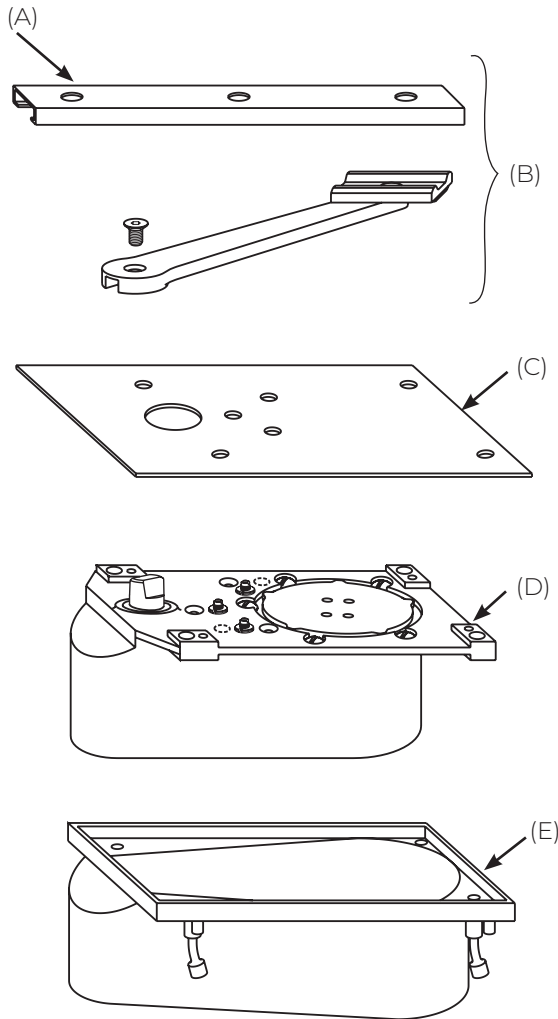

SCREW KITS

Slide Track Screw Kit
107033

Floor Plate Screw Kit
107004-*

Cement Case Screw Kit
107046

*specify finish

PARTS DRAWINGS

FLOOR CLOSERS

MODEL 28

- (A) Jamb Portion
3065
- (B) Finish Plate
012202-*PK(BRS)
012204-*PK(SS)
- (C) Door Portion
30243
- (E) Arm Plate Shims (.062)
46045-PKG (5)
Arm Plate Shims (.187)
46145-PKG (5)
- (F) Arm Plate & Stud Assy
46445
- (G) Arm Spindle Screw
01244010-PKG (5)
- (H) Arm Spindle Washer
01030-PKG (5)
- (I) Arm Set Screw Only
26087-PKG (5)
- (J) Arm & Arm Set Screw
282026M
- (K) Arm Alignment Screw &
Washer (2) of each
107032-*
- (L) Arm Spindle Collar
259000-*
- (M) Floor Plate with Screws
284020R* (RH) NHO
284020L* (LH) NHO
284720R* (RH) SHO
284720L* (LH) SHO
- (N) Closer Body
(Specify Complete
Model No. x LAP)
- (O) Cement Case with Screws
253000-PKG
- (P) Bottom Arm Package
(E-K)
282026-*

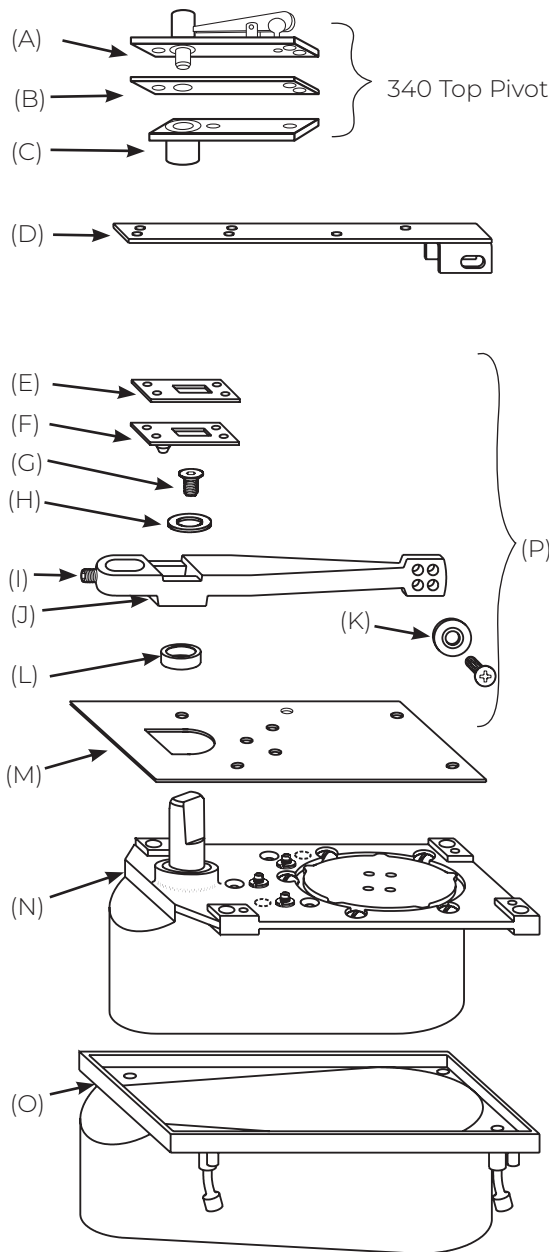

Wood Door Arm Package
282126 (includes D, E, F, J)

(D) W28 Wood Door Plate &
Shim Pkg
107066
(Includes 46145 & 46445)

554 Concealed Arm Package
282554
(Includes 107064)

SCREW KITS

340 Screw Kit
107329 Machine & Wood

Arm Screw Kit
107048-* Machine (2) Req
107144-* Wood (2) Req

554 Arm Screw Kit
107064

Floor Plate Screw Kit
107004-*

Cement Case Screw Kit
107046

*specify finish

MODEL H28

- (A) Jamb Portion
308548
- (B) Finish Plate
012202-*PK (BRS)
012204-*PK (SS)
- (C) Door Portion
30141
- (D) Standard End Load
Arm Package
(minimum 2" door
thickness)

262022
(Includes 107060, 107045,
and 107145)
- (E) Arm Spindle Collar
259500-*
- (F) Heavy-Duty Thrust
Bearing

41204-PKG (Includes
41207N)
- (G) Arm Shim Kit
107060
- (H) Floor Plate with Screws
NHO
284020R* (RH)
284020L* (LH)

SHO
284720R* (RH)
284720L* (LH)
- (I) Closer Body (Specify
Complete Model No. x
LAP)
(Includes 41204- PKG)
- (J) Cement Case with Screws
253001 - PKG

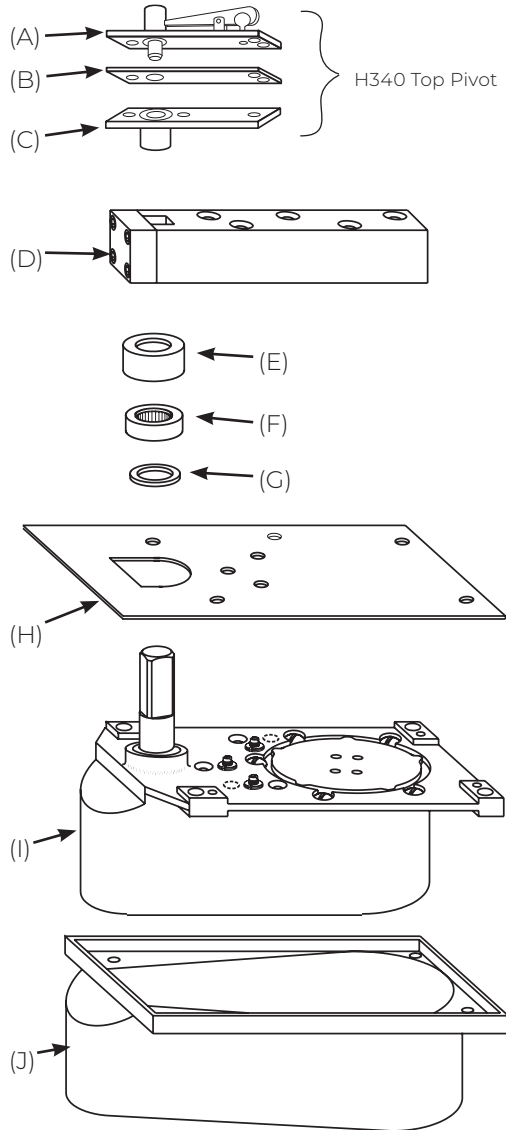

**587 SIDE LOAD ARM PACKAGE
FOR 1-3/4" DOOR**

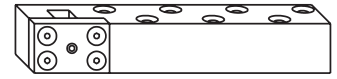

262587
(Includes G and attaching screws)

SCREW KITS

H340 Screw Kit
107329 Machine & Wood

587 Arm Screw Kit
107077 Machine
107145-* Wood

Arm Screw Kit
107045 Machine
107145 Wood

Floor Plate Screw Kit
107004-*

Cement Case Screw Kit
107046

*specify finish

PARTS DRAWINGS

FLOOR CLOSERS

MODEL 328/428

- (A) Jamb Portion
42801
- (B) Finish Plate
012202-*PK (BRS)
012204-*PK (SS)
- (C) Patch Fitting Cover
7495 - *
- (J) Bottom Pivot Insert
74101
- (K) Top Pivot Insert
74102

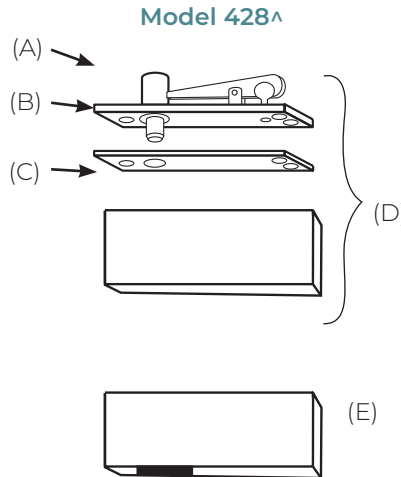

*^Model 428 includes patch fittings, top pivot, cement case, closer body and floor plate (D, E, F, G & H)

- (D) Top Patch
7494-* PK
(Includes C and K)
- (E) Bottom Patch
7495-* PK
(Includes C and J)

- (F) Floor Plate with
Screws NHO
NHO
284020R* (RH)
284020L* (LH)
SHO
284720R* (RH)
284720L* (LH)
- (G) Closer Body
(Specify Complete
Model No. x LAP)
- (H) Cement Case with
Screws
253000-PKG

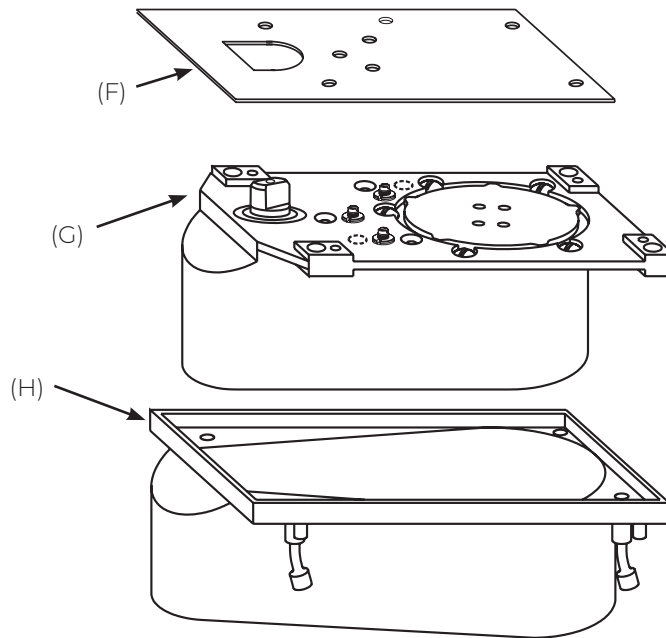

*specify finish

MODEL 30, 40

- (A) Jamb Portion
3065
- (B) Finish Plate
012202-*PK(BRS)
012204-*PK(SS)
- (C) Door Portion
30243
- (E) Arm Plate Shims
(.062) 46045-
PKG (5)
- (E) Arm Plate Shims (.187)
46145-PKG (5)
- (F) Arm Plate & Stud Assy
46445
- (G) Arm & Arm Set Screw
302026
- (H) Arm Set Screw Only
(5)
26087-PKG
- (I) Arm Alignment
Screw & Washer (2)
107032-*
- (J) Arm Spindle Collar
259000-*
- (K) Floor Plate with
Screws
(1 large and 1 small)
30 closer - 304020-
40 closer - 404020-*
- (L) Closer Body (Specify
Complete Model No. x
LAP)
- (M) Cement Case with
Screws
30 closer - 303000
40 closer - 403000

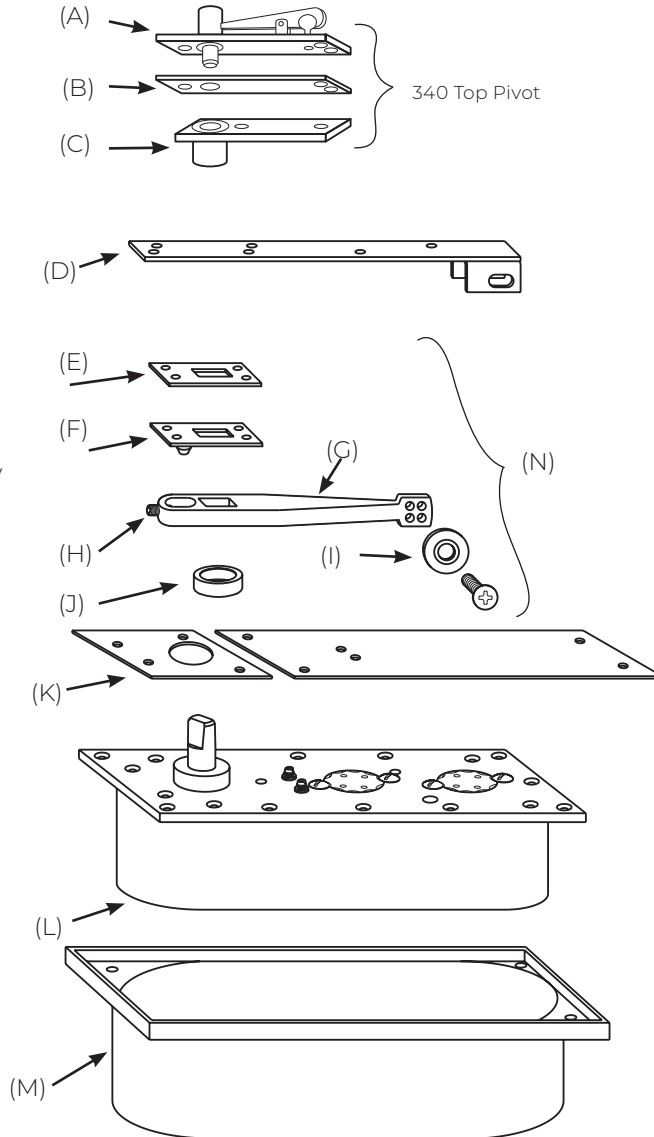

Wood Door Arm PKG
302126 (Includes D and G)

(D) Wood Door Plate & Shim PKG
107066 (Includes shims and
special arm centering screws)

(N) Bottom Arm Package
302026 -*
(Includes E, G, I, J and
attaching screws)

SCREW KITS

340 Screw Kit
107329 Machine & Wood

Arm Screw Kit
107048 Machine
107144 Wood

Floor Plate Screw Kit (2 req.)
107004-*

Cement Case Screw Kit
107014

*specify finish

PARTS DRAWINGS

FLOOR CLOSERS

MODEL H40

- (A) Jamb Portion
308548
- (B) Finish Plate
012202-*PK (BRS)
012204-*PK (SS)
- (C) Door Portion
30141
- (D) Standard End Load
Arm Package
(minimum 2" door
thickness)
262022
- (E) Arm Spindle Collar
259500-*
- (F) Heavy-Duty Thrust
Bearing
41204-PKG
- (G) Arm Shim Kit
107060
- (H) Floor Plate with
Screws
1 Large 1 Small
404020 -*
- (I) Closer Body (Specify
Complete Model No.
x LAP) (Includes
41204- PKG)
- (J) Cement Case with
Screws
403000

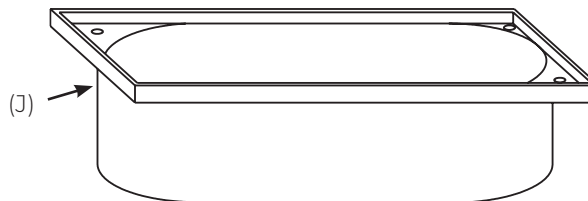
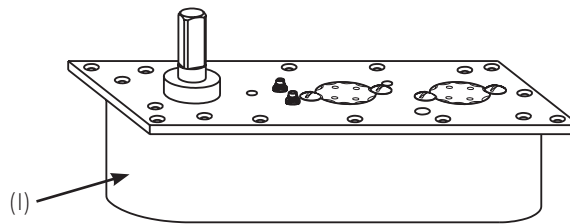
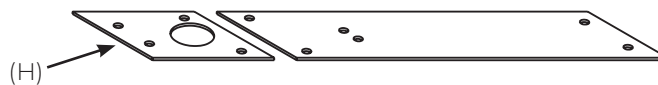
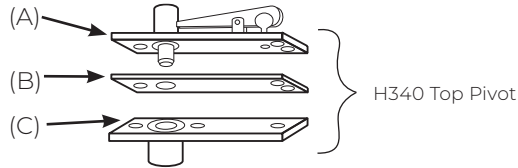

587 SIDE LOAD ARM PACKAGE FOR 1-3/4" DOOR

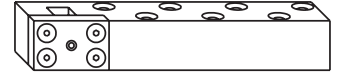

262587
(Includes G and attaching
screws)

SCREW KITS

H340 Screw Kit
107329 Machine & Wood

587 Arm Screw Kit
107077 Machine
107145 Wood

Arm Screw Kit
107045 Machine
107145 Wood

Floor Plate Screw Kit (2 req.)
107004-*

Cement Case Screw Kit
107014

*specify finish

FEATURES AND BENEFITS

Norton Rixson shallow depth floor closers provide long-lasting performance and reliability. Ideal for low to moderate traffic, interior doors, these closers are typically used in applications where traditional floor closer depth is too great. Shallow depth closers feature interchangeable spindle adapters, fixed spring sizes and separate and independent adjusting valves.

- Weight of the door is supported by the bottom arm and floor
 - Door swings with less resistance
 - Reduces stress on the frame
 - Fasteners are in shear, not tension
 - Eliminates door sag
 - Doors can be adjusted vertically
- Bottom arm attaches directly to the closer spindle
 - A mechanical advantage that increases efficiency insuring that ICC/ANSI A117.1 compliant, lower opening forces will still close the door
 - One to one ratio of door swing to spindle rotation makes control more precise
- Closer is concealed in the floor
 - Aesthetics -the beauty of the opening is the focal point, not the closer
 - Vandal resistance -the mechanism is not exposed
 - Solution for arch top doors (offset models)

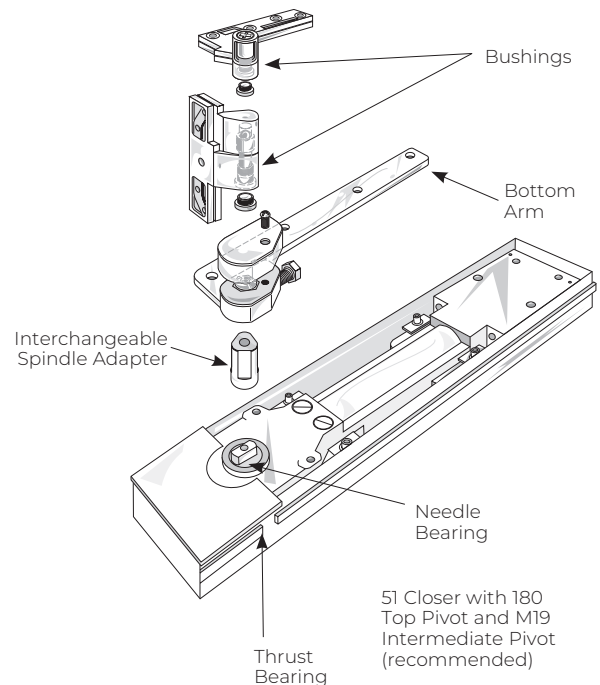

LIMITED WARRANTY

Norton Rixson shallow depth floor closers 50 and 51 series are warranted for 10 years against defect. See Price Book for specific details of the limited warranty.

SPECIFICATIONS

Interior door floor closers shall be models 50 (center hung), 51 (offset hung) or F53 (independently hung). These closers shall have separate and independent checking valves to control latch speed, closing speed and adjustable hydraulic backcheck. All closers shall have a minimum of two bearings internal to the closer. One shall be a thrust bearing and the other a needle bearing. Separate bearing surfaces shall be in the top pivot. Closers shall have cases no more than 2" deep. Fire rated model F51 shall have steel top pivots. Male spindle assemblies shall have removable spindle adapters, changeable in the field.

GLOSSARY OF TERMS

FLOOR CLOSERS

Delayed Action – Prefix DA

After full open permits door to remain ajar (at 70 degrees) for up to 40 seconds. Operates by separate valve and can be shut off if not needed. Not available on closers with hold open feature. Closers with DA feature do not have backcheck.

Wood Door – Prefix W

When using a center hung product with the centering arm (e.g., 5010 and 5020) a special plate and less obtrusive adjusting screws are needed for wood doors. This plate is reinforcement for the deep mortise required for that arm, protecting the veneer.

Fire Rated – Prefix F

Closer packages for fire rated doors (up to 3 hours) include a steel top pivot and must have additional steel intermediate pivots. These closers are non-hold open.

Twenty Minute Label – Suffix -20

This UL rating is for 20-minute doors. Pivots are brass-based material and include a visible label.

Less All Parts – Suffix LAP

If closer is needed for replacement, the arm, cover, cement case, top pivot and floor plate are omitted.

Less Floor Plate – Suffix LFP

When thresholds or cover pans are being used the closer doesn't need the decorative floor plate.

Less Cement Case – Suffix LCC

For existing installations or when cement case has been sent earlier in construction. Closer will be packaged without the cement case.

Less Top Pivot – Suffix LTP

For unusual head conditions where the top pivot cannot be used, the closer is shipped without the top pivot. For offset installations an additional load bearing intermediate (side jamb) M190 pivot is required. All intermediate pivots for that opening should be M190's, not M19's.

Non Hold Open – Suffix NBC

These closers do not hold the door open. This feature cannot be changed in the field.

Automatic Hold Open – Suffix ABC

These closers hold the door open. This feature cannot be changed in the field. Specify 90°, 105° or 180°.

Hand – Suffix RH or LH

All single acting floor closers are handed. All double acting floor closers (5020) are non-handed.

Extended Spindle – Suffix Extra Length

Any special coverings or severe door undercuts will require an extended spindle. See product template to determine if an extended spindle is needed. Extended spindles are available in 1/2" increments up to 2" longer than standard.

1-1/2" Offset – Suffix 1-1/2

Offset is the distance from the face of the door to the pivot point. Extended offsets should not be used unless there is cladding on the face of the door or there is trim to clear on the frame. 1-1/2" offset arms and pivots are for doors with cladding or trim that project 3/4" from the face of the door.

Cover Pan (Terrazzo) – Suffix Part Number

Closers should always be accessible. They should never be buried beneath flooring materials. A cover pan sits on top of the closer and has the flooring material set in it. This way the sight line for the floor is consistent. Cover pans may require closers with longer spindles. See cover pan template to determine spindle length needed.

Special Layouts – Suffix SPLO#

Unique installations or specially engineered products are called special layouts. These numbers must be assigned by the technical support department and they must be called out specifically by their number when ordered.

How to Determine Hand of Door



Face a door swinging open away from you. If it opens to the right, it is right handed. If it opens to the left, it is left handed.

MODEL 51

Application

- Interior Doors
- Weight to 250 lbs.*
- Door Width up to 4'0" (1219mm)

Features

- Single Acting
- Handed
- 180 top pivot included
- M19 intermediate pivot recommended (order separately)
- Order spring sizes 3 through 5:

Model	Door Width
5103	36" (914mm)
5104	42" (1067mm)
5105	48" (1219mm)

- Allows doors to swing 180°, trim permitting
- Available non-hold open (NBC) or automatic hold open (ABC) specify 90°, 105° or 180°
- Doors will swing 5° beyond hold open point
- Separate and independent valves for closing speed, latch speed and backcheck
- Available with floor plate or threshold installation (floor plate shown)
- Cylolac, rustproof cement case
- Vertical door adjustment
- Interchangeable spindle adapters
- Furnished with wood and machine screws
- For arch top doors or applications where a 180 top pivot cannot be used, supply at least two each M190 load bearing intermediate pivots, mounted together at the top of the vertical edge
- Doors up to 90" (2286mm) in height should use one intermediate pivot. Each additional 30" (762mm) warrants another intermediate pivot
- 2-year limited warranty

Optional Features

- Delayed action option – prefix "DA" (non-hold open only). Closer will not have backcheck
- Extended spindles available in 1/2" increments up to 2" longer than standard
- Available 1-1/2" offset, for doors with cladding or frames with applied molding. Maximum door weight 175 lbs.

Compliance

- For fire rated openings (up to 3 hour assemblies) prefix "F". This package will be supplied with a steel F180 top pivot and a non-hold open closer. FM19 intermediate pivot is required (order separately).
- For 20-minute label doors – suffix "-20" to the part number

**Door size & weight guidelines are determined using the appropriate number of intermediate pivots*



Technical Information

Frame stop required

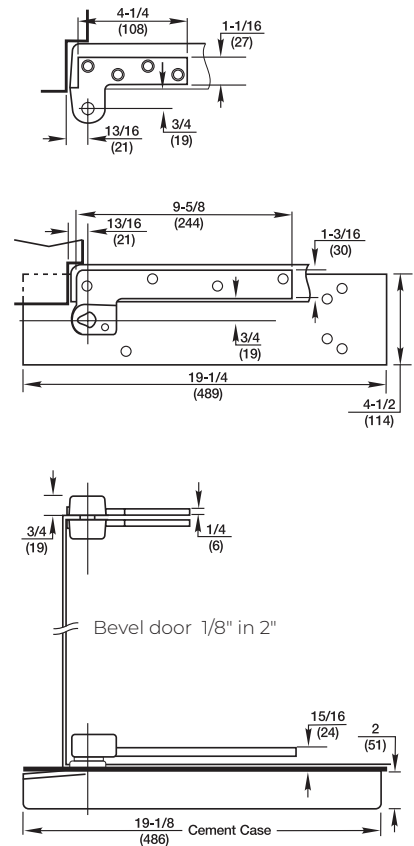

3/4" OFFSET HUNG FLOOR CLOSERS

MODEL Q /QT51

Application

- Interior Doors
- Weight to 250 lbs.*
- Door Width up to 4'0" (1219mm)
- 1-3/4" doors only

Features

- Single Acting
 - Handed
 - 180 top pivot included
 - For arch top doors, consult factory
 - One M19 intermediate pivot included
- Note: Closer cannot be ordered without the intermediate pivot*
- Order spring sizes 3 through 5

Model	Door Width
Q (QT) 5103	36" (914mm)
Q (QT) 5104	42" (1067mm)
Q (QT) 5105	48" (1219mm)

- Surface attached bottom arm allows closer removal without demounting door
- Mortise arm with thru bolt attachment
- Available non-hold open (NBC) or automatic hold-open (ABC) specify 90° or 105°
- Doors will swing 5° beyond hold open point
- Separate and independent valves for closing speed, latch speed and backcheck
- "Q" closers have a floor plate (shown)
- For threshold applications, prefix "QT" no floor plate will be supplied
- Cylolac, rustproof cement case
- Increased depth of cement case for easy closer removal
- Vertical door adjustment
- Interchangeable spindle adapters
- Furnished with machine and wood screws
- 3/4" offset only
- Doors up to 90" (2286mm) in height should use one intermediate pivot (included). Each additional 30" (762mm) warrants another intermediate pivot
- 2-year limited warranty

Optional Features

- Delayed-action option – prefix "DA" (non-hold open only). Closer will not have backcheck
- Extended spindles available in 1/2" increments up to 2" longer than standard

Compliance

- For fire rated openings (up to 3 hour assemblies), prefix "F". This package will be supplied with a steel F180 top pivot, one FM19 intermediate pivot and a non-hold open closer
- For 20-minute label doors suffix "20" to the part number



Technical Information

Frame stop required

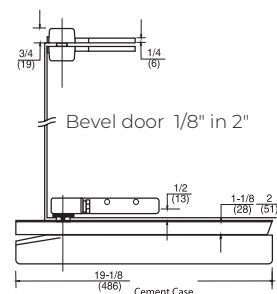
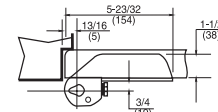
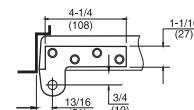

**Door size & weight guidelines are determined using the appropriate number of intermediate pivots*

3/4" OFFSET HUNG FLOOR CLOSERS

MODEL HM51

Application

- Interior Doors
- 1-3/4" Hollow Metal Doors & Frames
- Weight to 250 lbs.
- Door Width up to 4'0" (1219mm)

Features

- Single Acting
- Handed
- Designed for stock hollow metal doors and frames with standard weight 4-1/2" hinge preparation
- Three special steel 4-1/2" ball bearing standard weight hinges with 3/4" offset are included. Doors over 90" in height warrant an additional hinge.
- Order spring sizes 3 through 5:

Model	Door Width
HM5103	36" (914mm)
HM5104	42" (1067mm)
HM5105	48" (1219mm)

- Surface mounted bottom arm with thru bolts
- Available non-hold open (NBC) or automatic hold open (ABC) specify 90° or 105°
- Doors will swing 5° beyond hold open point
- Separate and independent valves for closing speed, latch speed and backcheck
- Available with floor plate or threshold installation (floor plate shown)
- Cicolac, rust proof cement case
- Interchangeable spindle adapters
- Furnished with 1/2 wood and full machine screws
- 2-year limited warranty

Optional Features

- Delayed action option – prefix "DA" (non-hold open closers only). Closer will not have backcheck
- Extended spindles available in 1/2" increments up to 2" longer than standard

Compliance

- For fire rated openings (up to 3-hour assemblies), prefix "F". This package will be supplied with three steel hinges and a non-hold open closer



Technical Information

Frame stop required

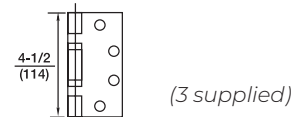
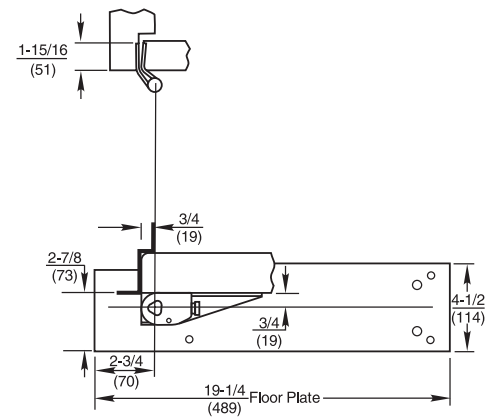

Bevel door 1/8" in 2"

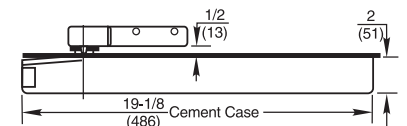

3/4" OFFSET HUNG FLOOR CLOSERS

MODEL M19

Application

- Full Mortise
- Handed

Features

- Not load bearing (pivot has a bushing)
- Maintains door alignment
- Aids in installing closers and floor closers
- Non ferrous base material
- 3/4" (19mm) offset standard
- Doors up to 90" (2286mm) in height should use one intermediate pivot. Each additional 30" (762mm) warrants another intermediate pivot
- For arch top doors or applications where a 180 top pivot cannot be used, supply at least two each M190 load bearing intermediate pivots, mounted together at the top of the vertical edge
- Furnished with wood and machine screws

Optional Features

- Available in 1-1/2" (38mm) offset

Compliance

- ANSI/C07321/C07371
- Available for fire door assemblies (ferrous material) specify FM19
- For 20-minute label suffix "-20" to the part number

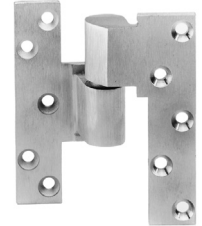

Technical Information

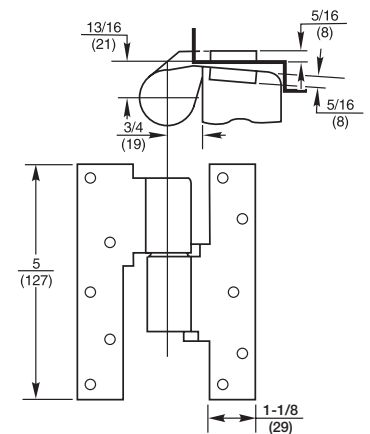

MODEL M190

Application

- Full Mortise
- Handed

Features

- Load bearing (pivot has a needle bearing)
- Maintains door alignment
- Aids in installing closers and floor closers
- Non ferrous base material
- 3/4" (19mm) offset standard
- Doors up to 90" (2286mm) in height should use one intermediate pivot. Each additional 30" (762mm) warrants another intermediate pivot
- For arch top doors or applications where a 180 top pivot cannot be used, supply at least two each M190 load bearing intermediate pivots, mounted together at the top of the vertical edge
- Furnished with wood and machine screws

Optional Features

- Available in 1-1/2" (38mm) offset

Compliance

- ANSI/C07321/C07371
- Available for fire door assemblies (ferrous material) specify FM190
- For 20-minute label suffix "-20" to the part number



Technical Information

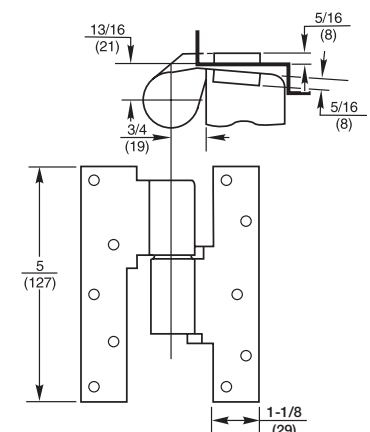

INDEPENDENTLY HUNG FLOOR CLOSERS



MODEL F53 AND F5310

Application

- Interior Doors
- Door Width up to 4'0" (1219mm)
- Weight to 250 lbs.

Features

- Single Acting
- Handed
- Used to conceal floor closer for independently hung doors (butt hinges, pocket pivots, etc)
- Closer does not support weight of door
- Order spring sizes 3 through 5:

Model	Door Width
F5303	36" (914mm)
F5304	42" (1067mm)
F5305	48" (1219mm)

- Auxiliary stop recommended
- Includes closer, mortised rail and arm with slider
- Maximum swing 90°
- Separate and independent valves for closing speed, latch speed and backcheck
- Floor plate standard. For threshold applications a 1/2" extended spindle is required
- Cicolac rustproof cement case
- Interchangeable spindle adapters
- Furnished with wood and machine screws
- 2-year limited warranty

Note: Hanging means used must be specified when ordering. Check product template. If hanging means is not listed, contact factory for special layout and pricing.

F5310 ONLY:

For use in 90° pocket door installations where closer is located in the pocket. Can only be used with F519 pocket pivots.

- Specially milled spindle allows positive latch speed control

Optional Features

- Not available in "DA" or hold open
- Extended spindles available in 1/2" increments up to 2" longer than standard

Compliance

- This closer carries a UL listing for 3-hour fire door assemblies. Fire rated hanging means required.

Technical Information

Frame stop required

Door shown parallel to frame

F53

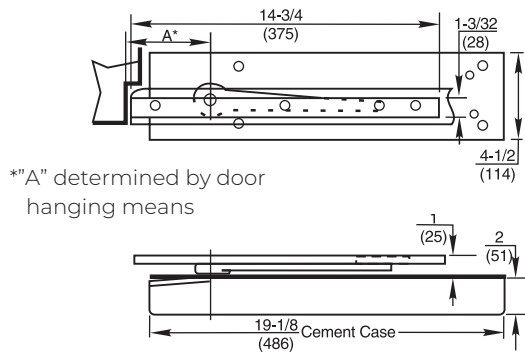

**"A" determined by door hanging means

F5310

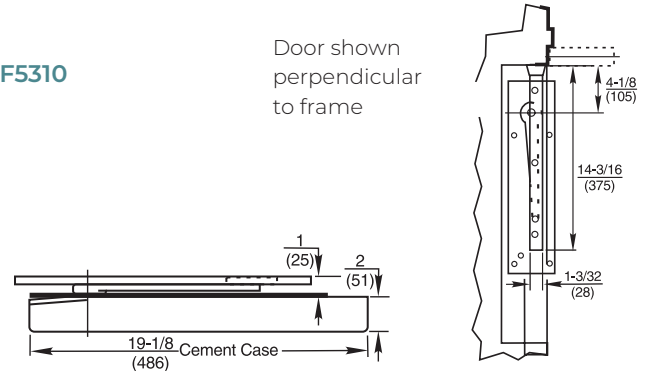

Door shown perpendicular to frame

INTERMEDIATE PIVOTS

FLOOR CLOSERS

MODEL 519

Application

- Pocket Door Pivot
- Non-Handed

Features

- Full mortise, pivot for pocket door applications
- Heavy-duty steel pivot with ball bearings
- Allows doors to swing 90°
- Minimum three pocket pivots per door
- Doors over 90" (2286mm) in height require four pocket pivots. Each additional 30" (762mm) warrants another pocket pivot
- Furnished with wood and machine screws

Compliance

- ANSI/A8911/C07611
- UL listed for all labeled pocket fire-door assemblies up to and including 3 hours
- Fire-rated door assemblies must have been tested with pocket pivots



Technical Information

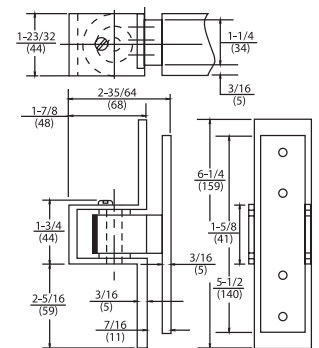

CENTER HUNG, SINGLE ACTING FLOOR CLOSERS

MODEL 50

Application

- Interior Doors
- Centering Arm
- Weight to 250 lbs.
- Door Sizes up to 4'0" x 8'0" (1219 x 2438mm)

Features

- Single Acting
- Handed
- 340 top pivot included
- Order spring sizes 3 through 5:

Model	Door Width
5013	36" (914mm)
5014	42" (1067mm)
5015	48" (1219mm)

- Centering arm with adjustment screws in faces of door
- Available non-hold open (NBC) or automatic hold open (ABC) specify 90° or 105°
- Separate and independent valves for closing speed, latch speed and backcheck
- Available with floor plate or threshold installation (floor plate shown)
- Cylolac, rustproof cement case
- Frame stop required at lock edge. If not supplied by frame manufacturer, recommend use of 60131 (see Door Control Accessories Catalog)
- Interchangeable spindle adapters
- Furnished with wood and machine screws
- 2-year limited warranty

Optional Features

- Delayed action option – prefix "DA" (non-hold open only). Closers will not have backcheck
- Extended spindles available in 1/2" increments up to 2" longer than standard
- Arm reinforcement bracket for wood doors prefix "W"



Technical Information

Frame stop required at lock edge

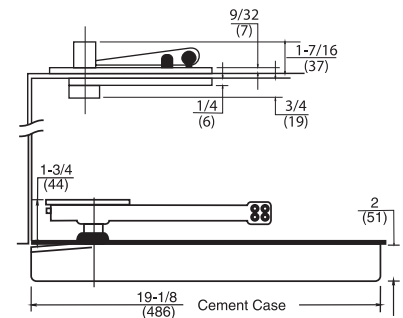
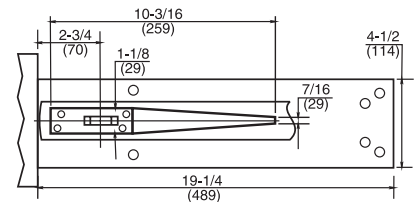

Door edges must be radiused

Note: Center hung closers are not allowed for use on fire rated doors.

CENTER HUNG, SINGLE ACTING FLOOR CLOSERS

MODEL 50 X 554 ARM

Application

- Interior Doors
- Concealed Arm
- Weight to 250 lbs.
- Door Sizes up to 4'0" x 8'0" (1219 x 2438mm)

Features

- Single Acting
- Handed
- 340 top pivot included
- Order spring sizes 3 through 5:

Model	Door Width
5013 x 554	36" (914mm)
5014 x 554	42" (1067mm)
5015 x 554	48" (1219mm)

- Concealed arm is designed to eliminate visible adjusting screws on face of door visible adjusting screws on face of door
- Arm bolt locks arm to closer spindle – adjustment made through heel of door
- Available non-hold open (NBC) or automatic hold open (ABC) specify 90° or 105°
- Separate and independent valves for closing speed, latch speed and backcheck
- Available with floor plate or threshold installation (floor plate shown)
- Cyclac, rustproof cement case
- Frame stop required at lock edge. If not supplied by frame manufacturer, recommend use of 60131 (see Door Control Accessories Catalog)
- Interchangeable spindle adapters
- Furnished with wood and machine screws
- 2-year limited warranty

Optional Features

- Delayed action option – prefix "DA" (non-hold open only) closer will not have backcheck
- Extended spindles available in 1/2" increments up to 2" longer than standard



Technical Information

Frame stop required at lock edge

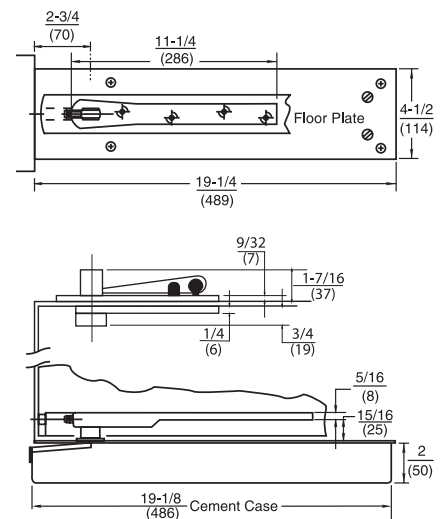

Door edges must be radiused

Note: Center hung closers are not allowed for use on fire rated doors.

CENTER HUNG, SINGLE ACTING FLOOR CLOSERS

MODEL 5040

Application

- Interior, Full Glass Doors
- Weight to 200 lbs.
- Door Sizes 3'6" x 8'0" (1067-2438mm)

Features

- Single acting
- Handed
- Special top pivot included
- Top and bottom patch fittings for tempered glass doors 3/8" - 1/2" thick
- Order spring sizes 3 and 4:

Model	Door Width
5043	36" (914mm)
5044	42" (1067mm)

- Available non-hold open (NBC) or automatic hold open (ABC) specify 90° or 105°
- Separate and independent valves for closing speed, latch speed and backcheck
- Floor plate standard. For threshold application, an extended spindle is required (floor plate shown). There is no vertical adjustment
- Cylolac rustproof cement case
- Interchangeable spindle adapters
- 2-year limited warranty

Optional Features

- Delayed action option – prefix "DA" (nonhold open only). Closers will not have backcheck. DA is not recommended for full glass doors
- For extended spindles contact factory



Technical Information

Frame stop required at lock edge

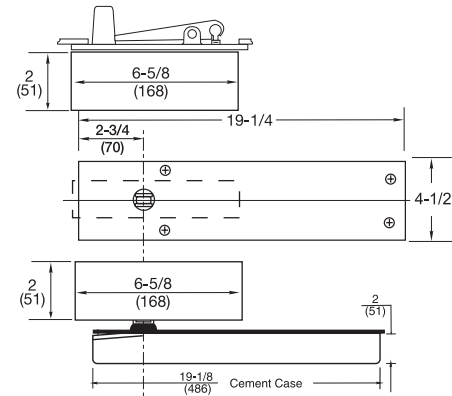

Note: 5040 closers are only available in the following finishes: 605, 629 and 630.

CENTER HUNG, DOUBLE ACTING FLOOR CLOSERS

MODEL 5020

Application

- Interior Doors
- Centering Arm
- Weight to 250 lbs.
- Door Sizes up to 4'0" x 8'0" (1219 x 2438mm)

Features

- Double Acting
- Non-handed
- 340 top pivot included
- Order spring sizes 3 through 5:

Model	Door Width
5023	36" (914mm)
5024	42" (1067mm)
5025	48" (1219mm)

- Centering arm with adjustment screws in faces of door (critical for double acting doors)
- Available non-hold open (NBC) or automatic hold open (ABC) specify 90°, 105°
- Door may only swing 130° in either direction
- Auxiliary stop required
- Separate and independent valves for closing speed, latch speed and backcheck
- Available with floor plate or threshold installation (floor plate shown)
- Cylolac, rustproof cement case
- Interchangeable spindle adapters
- Furnished with wood and machine screws
- 2-year limited warranty

Optional Features

- Delayed action option – prefix "DA" (nonhold open only). Closers will not have backcheck
- Extended spindles available in 1/2" increments up to 2" longer than standard
- Arm reinforcement bracket for wood doors – prefix "W"



Technical Information

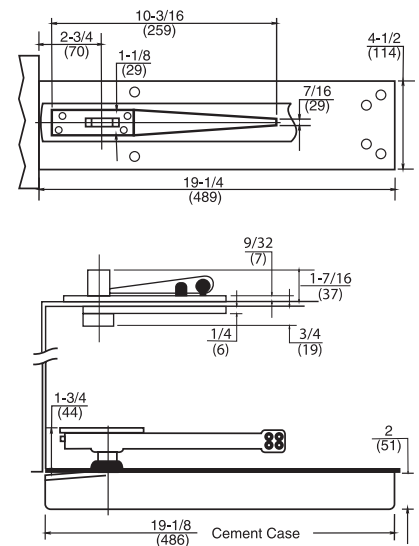

Door edges must be radiused

Note: Center hung closers are not allowed for use on fire rated doors.

OPTIONAL CENTER HUNG TOP PIVOT FLOOR CLOSERS

MODEL 345

Application

- Fully Concealed
- Non-handed
- Earthquake Tolerant
- Taller Doors (8'0" to 9'0")

Features

- Center Hung
- Non-Handed
- Ideal for locations where there is a fear that dramatic building settling is possible
- Long pivot pin engages in top of door 1-3/4" (44mm).
- Can be used with any center hung floor closer. Order the closer LTP (less top pivot) and the 345 top pivot separately
- Walking beam-type pivot - 1/2" (13mm) diameter pivot pin
- Oil-impregnated sintered bronze bearing
- Completely concealed when door is closed
- Furnished with wood and machine screws

Compliance

- ANSI/C07021

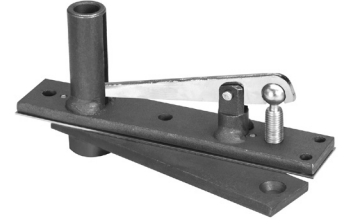

Technical Information

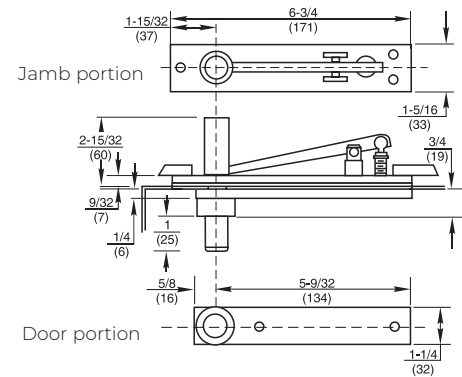

HOW TO ORDER

FLOOR CLOSERS

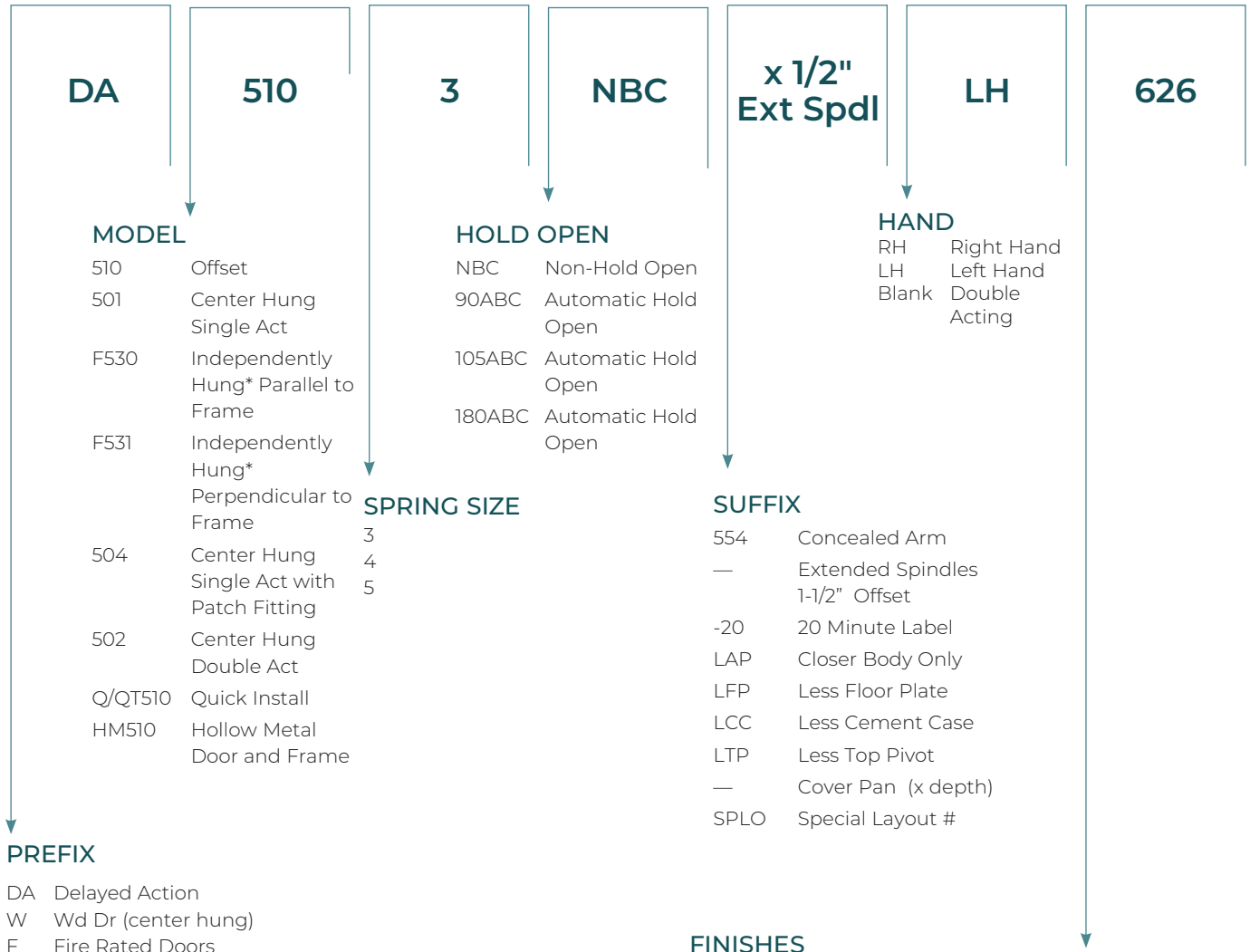

PREFIX
 DA Delayed Action
 W Wd Dr (center hung)
 F Fire Rated Doors

**Hanging means must be noted on purchase order.*

FINISHES

Description	Specify Norton Rixson Designation (BHMA)
605	Bright Brass
606	Satin Brass
611	Bright Bronze
612	Satin Bronze
613	Antique Bronze
613E	Dark Oxidized Satin Bronze - equivalent
618	Bright Nickel
619	Satin Nickel
622	Flat Black
625	Bright Chrome
626	Satin Chrome
BSP	Black Suede Powder
WSP	White Suede Powder

5040 only available in 605, 629 and 630

PRODUCT COMPARISON CHART

FLOOR CLOSERS

OFFSET HUNG	51	Q/QT51 ⁴	HM51 ³
Application	Standard	Surface attached bottom arm allows closer removal without demounting door	Stock hollow metal doors with standard weight 4-1/2" hinge prep
3/4" offset standard	*	*	*
1-1/2" offset optional¹	*		
Handed	*	*	*
Non-hold open	*	*	*
Automatic hold open	90°, 105° or 180°	90°, or 105°	90°, or 105°
Spring sizes	3, 4 or 5	3, 4 or 5	3, 4 or 5
Door weight	250 lbs.	250 lbs.	250 lbs.
Maximum door width	48"	48"	48"
Top pivot (included)	180 top pivot	180 top pivot	N/A
Extended spindles²	*	*	*
1-3/4" doors only		*	*
Options	DA, F, -20	DA, F, -20	DA, F

1. Recommended door weight will be approx. half when 1-1/2" offset is specified

2. 1/2" increments up to 2"

3. Shipped with (3) special hinges

4. Q: includes floor plate, QT: for threshold applications

5. Delayed Action only available with NHO closers

Optional Features	Designation
Delayed Action ⁵	DA
Fire-Rated	F
20 Minute Label	-20

CENTER HUNG	50	50 x 554 Arm	5020	5040
Application	Standard	Standard; concealed arm eliminates visible adjusting screws	Standard	Full glass doors
Single acting	*	*		*
Double acting			*	
Handed	*	*		*
Non-hold open	*			
Automatic hold open	90°, or 105°	90°, or 105°	90°, or 105°	90°, or 105°
Door weight	250 lbs.	250 lbs.	250 lbs.	200 lbs.
Spring sizes	3, 4 or 5	3, 4 or 5	3, 4 or 5	3, or 4
Maximum door width	48"	48"	48"	42"
Top pivot (included)	340 top pivot	340 top pivot	340 top pivot	Special top pivot
Extended spindles¹	*	*	*	Contact factory
Options	DA	DA, W	DA, W	

* Center hung closers are not allowed on fire rated doors

• Doors taller than 8'6", use 345 in lieu of 340 top pivot

1. 1/2" increments up to 2"

2. Delayed Action only available with NHO closers

Optional Features	Designation
Delayed Action ²	DA
Arm reinforcement bkt for Wood Doors	W

PARTS DRAWINGS

FLOOR CLOSERS

MODEL 51

RIGHT HAND SHOWN 3/4" OFFSET

- (A) Pivot Stud
181770-ASY
- (B) Hex Cap
181778-*
- (C) Arm Cap & Screw
012142R*AS (RH, BRS)
012142L*AS (LH, BRS)
012144R*AS (RH, SS)
012144L*AS (LH, SS)
- (D) 3/4" Offset Arm x
Locking Screw
275177 (RH)
275176 (LH)
- (E) Arm Locking Screw Only
PKG (5) 88905
- (G) Arm Bearing Washer
275062-PKG (5)
- (H) Spindle Washer
519000-*

For 51 x 1-1/2" Offset
180x1-1/2" (standard)
F180x1-1/2"
(fire rated up to 3
hours)

180-20x1-1/2"
(20 minutes)

1-1/2" Offset Arm x
Locking Screw
275167-*

1-1/2" Offset Bottom
Arm pkg
252060-*

*specify finish

- (M) 3/4" Offset Top Pivot Assembly
180 (standard)
F180 (fire rated up to 3 hours)
180-20 (20 minutes)

- (N) Bottom Arm
Package
(Includes C, D and
attaching screws)
252050R* (RH)
252050L* (LH)

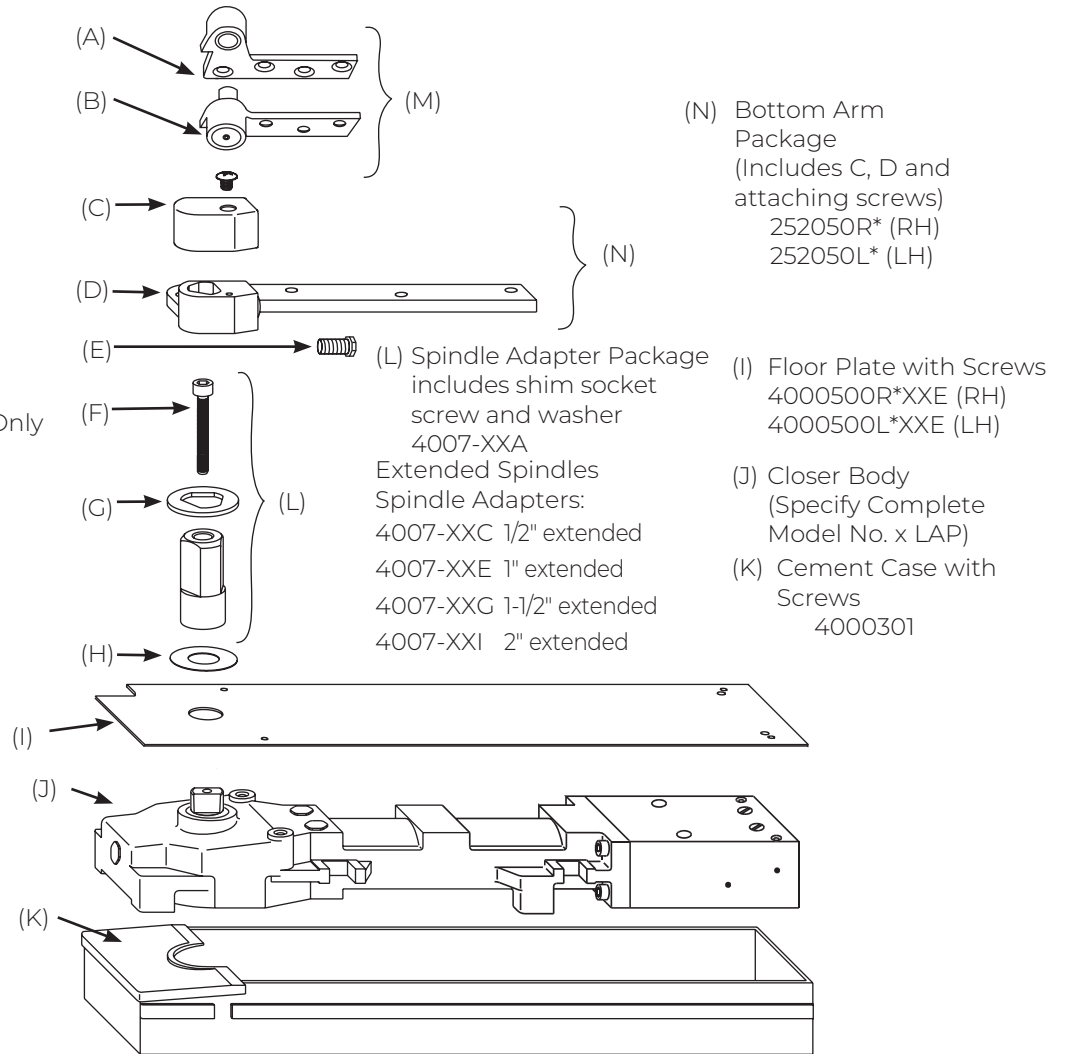

- (L) Spindle Adapter Package
includes shim socket
screw and washer
4007-XXA
Extended Spindles
Spindle Adapters:
4007-XXC 1/2" extended
4007-XXE 1" extended
4007-XXG 1-1/2" extended
4007-XXI 2" extended

- (I) Floor Plate with Screws
4000500R*XXE (RH)
4000500L*XXE (LH)

- (J) Closer Body
(Specify Complete
Model No. x LAP)
- (K) Cement Case with
Screws
4000301

SCREW KITS

- 180 Screw Kit
107014 Machine (2) Req
107114 Wood (2) Req
- Arm Screw Kit
107044 Machine
107144 Wood
- Floor Plate Screw Kit
107004-*
- Cement Case Screw Kit
107075

MODEL Q51/QT51

RIGHT HAND SHOWN
3/4" OFFSET

- (A) Pivot Stud
181770-ASY
- (B) Hex Cap
181778-*
- (C) Arm Cap & Screw
73035R*AS (RH, BRS)
73035L*AS (LH, BRS)
- (D) Q/QT51 Arm Mounting
Screws & Plate 73014-*
- (E) Removable Arm
73001R-ASY (RH)
73001L-ASY (LH)
- (F) Arm Locking Screw Only
88905-PKG (5)
- (G) Arm Washer & Shim
Package
275179
includes shim 275065 &
275178 torque washers
- (I) Spindle Washer
519000-*

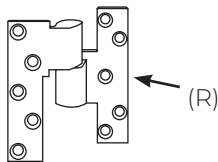

M19 Intermediate
Pivot

- (R) 3/4" Offset
Intermediate Pivot (I)
M19
FM19
Fire Rated
M19-20
20 Minute

*specify finish

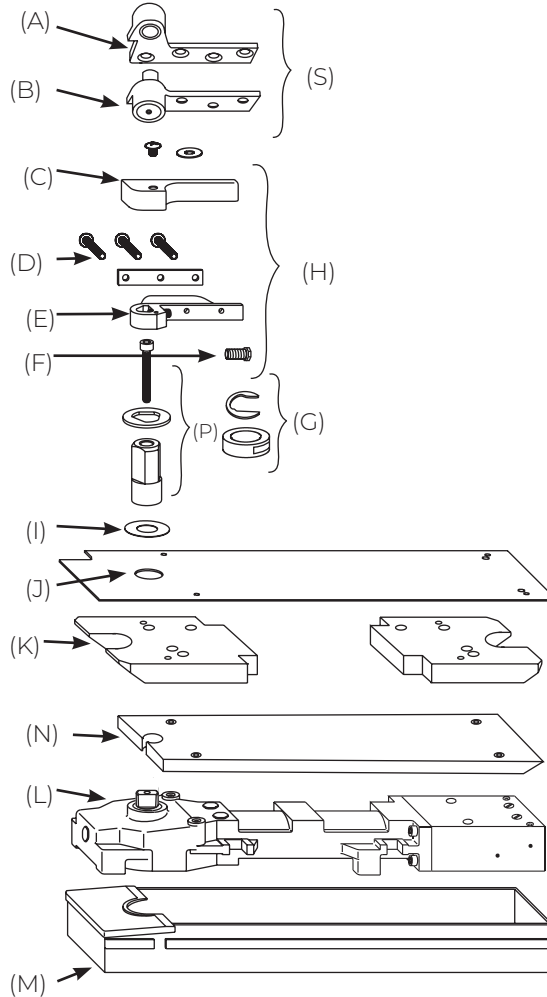

- (S) 3/4" Offset Top Pivot
180
FL180
Fire Rated
180 - 20
20 Minute
- (H) Bottom Arm Package
222050R* (RH)
222050L* (LH)
(Includes C, D, E, F)
- (P) Spindle Adapter
Package
4007-XXC
(Includes shims, socket
screw & washer)
Extended Spindles
Spindle Adapters:
4007-XXE 1/2" extended
4007-XXG 1" extended
- (J) Floor Plate w/Screws
4000501R* XXE
(RH), ("BC")
4000501L* XXE
(LH), ("BC")
- (K) Q51 Styrofoam Filler
4000023
- (N) QT51 Styrofoam Filler
4000019
- (L) Closer Body
(Specify complete
model no. x LAP)
- (M) Cement Case w/
Screws 4000301

SCREW KITS

- 180 Screw Kit
107014 Machine (2) Req
107114 Wood (2) Req
- Q Floor Plate Screw Kit
107010-*
- Cement Case Screw Kit
107075
- M19 Intermediate Pivot
Screw Kit
107015 Machine (2) Req
107115 Wood (2) Req

PARTS DRAWINGS

FLOOR CLOSERS

MODEL HM51

**RIGHT HAND SHOWN
3/4" OFFSET**

- (A) Arm Cap & Screw
73025R*AS (RH)
73025L*AS (LH)
- (B) HM51 Arm Mounting
Screws & Plate
73014-*
- (C) Arm & Screw
73041R*AS (RH)
73041L*AS (LH)
- (D) Arm Locking Screw
Only
88905 - (5)
- (E) Arm Bearing Washer
275062-PKG (5)
- (F) Spindle Washer
519000-*

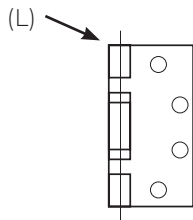
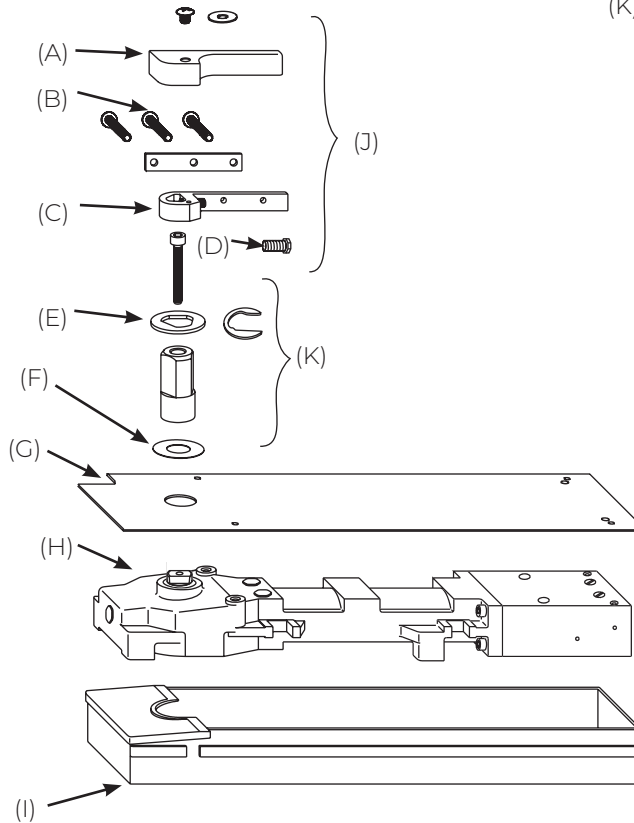

- (L) Special Offset Hinges (3)
254545R*PK
254545L*PK

- (J) Bottom Arm Package
222050R*HM (RH)
222050L*HM (LH)
(Includes A, B, C)

- (K) Spindle Adapter Package
4007-XXA

Extended Spindles
Spindle Adapters:
(Includes shims, arm washer
& socket screw)

- 4007-XXC 1/2" extended
- 4007-XXE 1" extended
- 4007-XXG 1-1/2" extended
- 4007-XXI 2" extended

- (G) Floor Plate w/Screws
4000501R* XXE (RH, "BC")
4000501L* XXE (LH, "BC")

- (H) Closer Body
(Specify complete
model no. x LAP)

- (I) Cement Case with Screws
4000301

SCREW KITS

- Floor Plate Screw Kit
107004-*
- Cement Case Screw Kit
107075
- Hinge screw kit
107519-*

*specify finish

MODEL F53 AND F5310

- (A) Door Rail
327006
- (C) Spindle Washer
519000-*

- (B) Bottom arm package
3252010-*
- (D) Floor Plate with screws
4000600-XXA
4000600-XXE ("BC")
- (E) Closer Body (specify
complete model no. LAP)
- (F) Cement case with screws
4000301

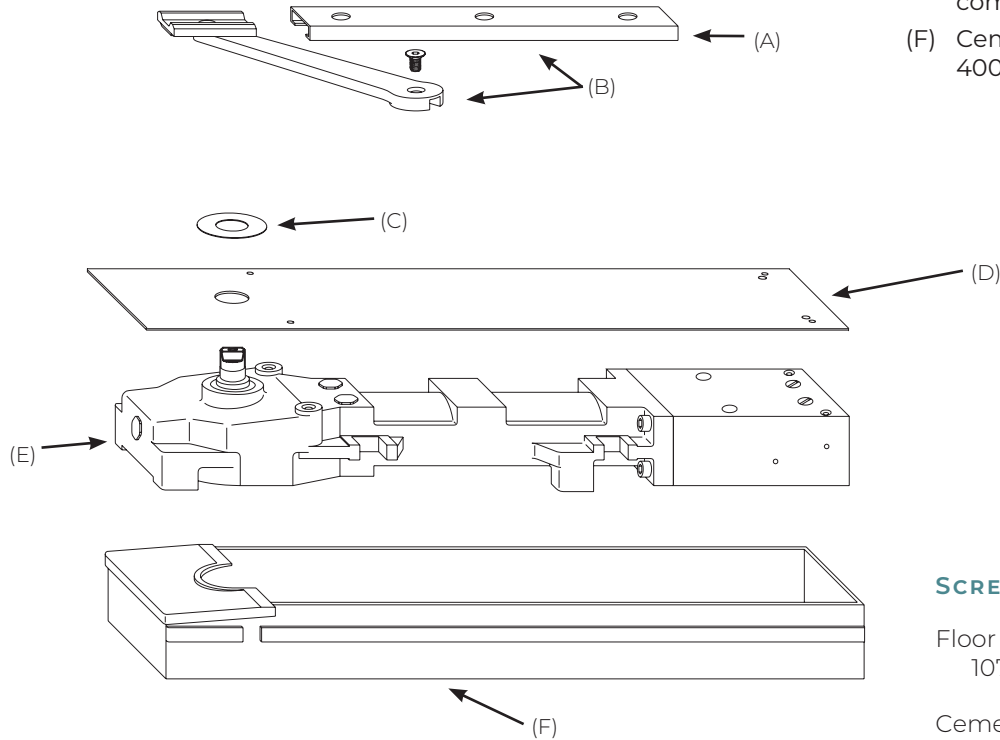

SCREW KITS

Floor Plate Screw Kit
107004-*

Cement Case Screw Kit
107075

Slide Track Screw Kit
107033

SPINDLE ADAPTER PACKAGE
includes socket screw

Extended Spindle Adapters

- 4009-XXC 1/2" extended
- 4009-XXE 1" extended
- 4009-XXG 1-1/2" extended
- 4009-XXI 2" extended

*specify finish

PARTS DRAWINGS

FLOOR CLOSERS

MODEL 50 AND 5020

(A) Jamb Portion
3065

(B) Finish Plate
012202-*PK(BRS)
012204-*PK(SS)

(C) Door Portion
30243

(D) W28 Wood Door
Plate/Shim Pkg
107066
(Includes E and F)
Wood door arm pkg.
282126
(Includes D and G)

(E) Arm Plate Shims (.062)
46045-PKG (5)
Arm Plate Shims (.187)
46145-PKG (5)

(F) Arm Plate & Stud Assy
46445

(G) Arm & Arm Set Screw
282026

(H) Arm Set Screw Only
26087-PKG (5)

(I) Arm Alignment
Screw & Washer
107032-*

(K) Spindle Washer
519000-*

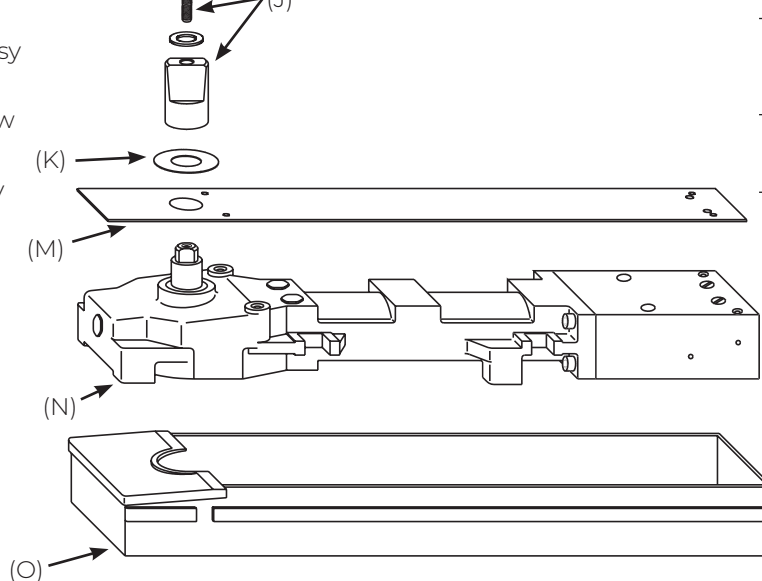
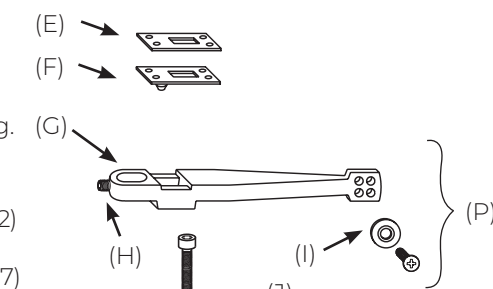
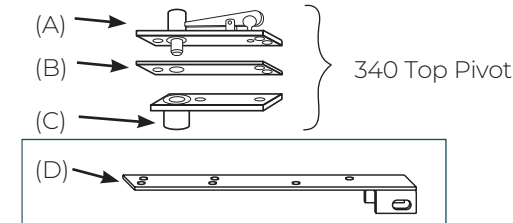

(L) 554 Concealed Arm Package
282554

Note: Cannot be used on model 5020

(M) Floor Plate with Screws
4000600-*XXE
4000600-*XXE ("BC")
4000600-*XXI ("DA")

(N) Closer Body
(Specify Complete
Model No. x LAP)

(O) Cement Case with Screws
4000301

(P) Bottom Arm Package
282026-
(Includes H, G and I)

(J) Spindle Adapter Package
4010-XXA
(Includes socket screw & shim)

Extended Spindles
Spindle Adapters
4010-XXC 1/2" extended
4010-XXE 1" extended
4010-XXG 1-1/2" extended
4010-XXI 2" extended

SCREW KITS

554 Arm Screw Kit
107064

Floor Plate Screw Kit
107004-*

Cement Case Screw Kit
107075

340 Screw Kit
107329 Machine
& Wood

Arm Screw Kit
107048 Machine
107144 Wood

*specify finish

MODEL 5040

RIGHT HAND SHOWN
3/4" OFFSET

(A) Jamb Portion
42801

(B) Finish Plate
012202-*PK (BRS)
012204-*PK (SS)

(C) Patch Filling
7495-*

(J) Bottom Pivot Insert
74101

(L) Top Pivot Insert
74102

(K) Spindle Washer
519000-*

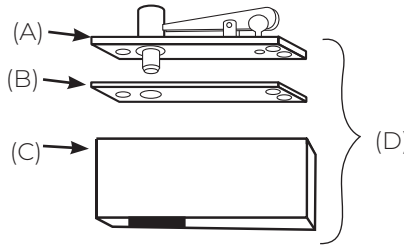

(D) Top Patch
7494* PK
(Includes C and L)

(M) Floor Plate with Screws
4000600-*XXE ("BC")

(N) Closer Body
(Specify Complete
Model No. x LAP)

(O) Cement Case with Screws
4000301

(E) Bottom Patch
7495*PK
(Includes C and J)

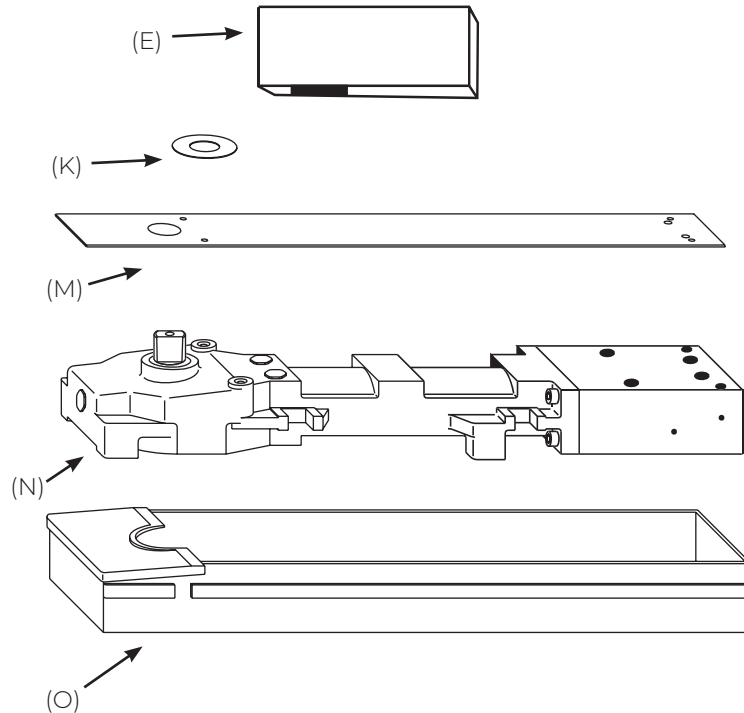

SCREW KITS

Floor Plate Screw Kit
107004-*

Cement Case Screw Kit
107075

340 Screw Kit
Machine & Wood
107329

NOTES

FLOOR CLOSERS

The ASSA ABLOY Group is the global leader in access solutions.
Every day, we help billions of people experience a more open world.

ASSA ABLOY Opening Solutions leads the development within door openings and products for access solutions in homes, businesses and institutions. Our offering includes doors, frames, door and window hardware, mechanical and smart locks, access control and service.



ASSA ABLOY

Since 1880, Norton Rixson door controls have been an integral part of schools, hospitals and businesses around the globe. When you need products and people that perform at the highest level, rely on Norton Rixson – From Open to Close.

NORTON RIXSON | WWW.NORTONRIXSON.COM

3000 Highway 74 East | Monroe, NC 28112 | Tel: 1 877 974 2255

ASSA ABLOY OPENING SOLUTIONS DOOR SECURITY SOLUTIONS CANADA | WWW.ASSAABLOYDSS.CA

160 Four Valley Drive | Vaughan, Ontario, L4K 4T9 Canada | Tel: 800 461 3007