

H600S-SW Series

For Sliding Panels up to 600 lbs.
Manufactured by P.C. Henderson

HENDERSON

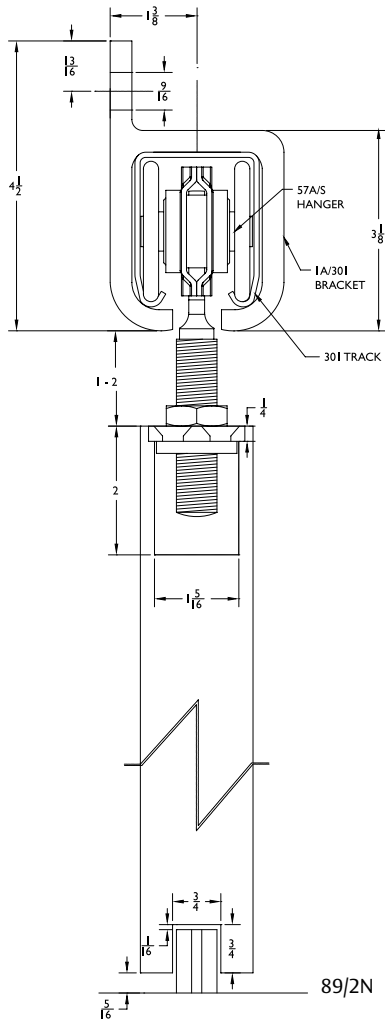

Configurations:

- Single
- Bi-parting

Installations:

- Side Wall Mount

Features:

- Side wall mount system
- Heavy duty zinc coated steel
- Ball bearing wheels
- 600 lb. panel capacity
- Galvanized steel track 301
- 2 year warranty

H600S-SW Kits Include:

- 1 ea **301** Galvanized Steel Track
- **1A/301** Side Wall Mount Track Brackets
(One at each end and no more than three feet in between)
- 2 ea **1A/301/EC** Aluminum Alloy End Caps
- 2 ea **57A/S** Zinc Coated Steel Body, Wheels, and Pendant Bolt Hangers
- 2 ea **HH3/301** Galvanized Steel In-Track Stops
- 1 ea **89/2N** Gray Nylon Mortise Guide

Standard Kit Sizes

Part Number	Material	Track Length	Door Width
H600S-SW/6	Steel	72"	36"
H600S-SW/8	Steel	96"	48"
H600S-SW/10	Steel	120"	60"
H600S-SW/12	Steel	144"	72"

Options: See page 49

- Bottom Channel **94A**
- Roller Guide **106R/94**
- Mortise Guides **102N**
- Side Wall Mortise Guides **102WN**
- Joining Bracket **1AX/301**