

# H1100A-SW Series

For Sliding Panels up to 1100 lbs.  
Manufactured by P.C. Henderson

HENDERSON

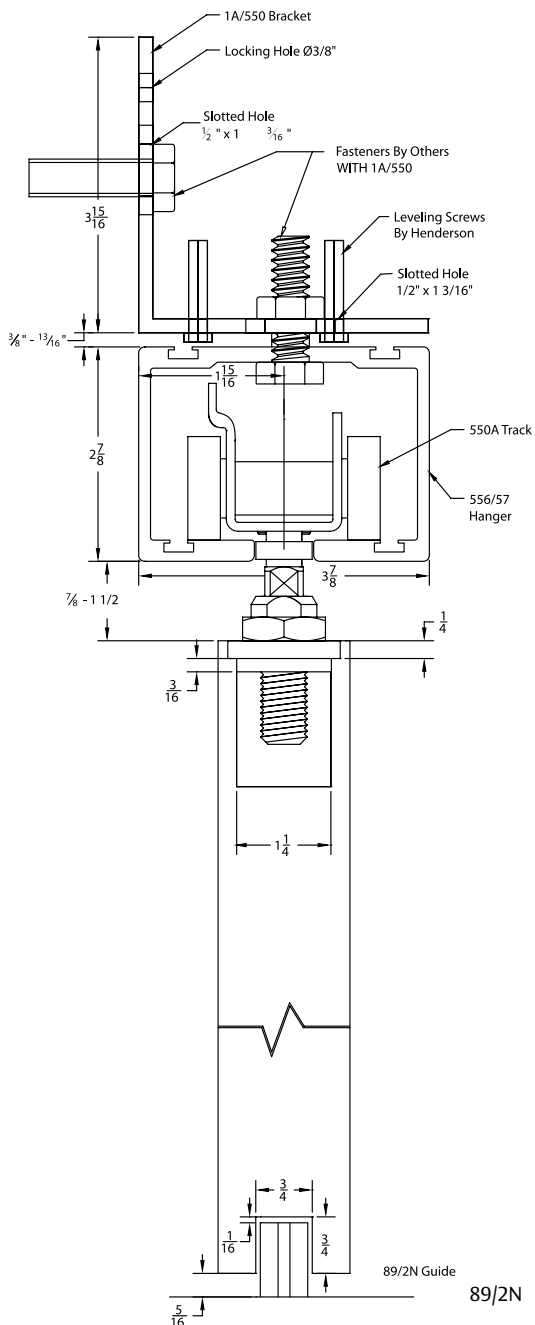

Ideally suited for large doors that require high performance and an attractive finish.

Typical applications are hotels, conference centers, shop-fronts and showrooms.

**Configurations:**

- Single
- Bi-parting

**Installations:**

- Side Wall Mount

**Features:**

- Heavy duty black painted steel body ball bearing wheels
- 1100 lb. panel capacity
- Mill finished aluminum track 550A
- 2 year warranty

**H1100A-SW Kits Include:**

- 1 ea **550A** Mill Finished Aluminum Track
- **1A/550** Aluminum Alloy Side Wall Track Bracket  
Fastners not included with 1A/550. (One at each end and no more than three feet in between)
- 2 ea **556/57** Painted Black Steel Body - Zinc Coated Steel Wheels and Pendant Bolt Hangers
- 2 ea **HH3/301** Galvanized Steel In-Track Stops
- 1 ea **89/2N** Gray Nylon Mortise Guide

Standard Kit Sizes			
Part Number	Material	Track Length	Door Width
H1100A-SW/6	Aluminum	72"	36"
H1100A-SW/8	Aluminum	96"	48"
H1100A-SW/10	Aluminum	120"	60"
H1100A-SW/12	Aluminum	144"	72"
H1100A-SW/16	Aluminum	197"	98"

**Options:** See page 49

- Bottom Channel **94A**
- Roller Guide **106R/94**