



GAP90™ AND GAP90DKB™

Fire Door Head/Jamb Gap Solutions— Up To 90 Minutes

PRODUCT CUT SHEET

PROJECT:
SUBMITTED BY:
DATE:
NOTES:

UL Certified for Head/Jamb Gaps
— Measuring over 1/8", and up to 5/16".



- ▶ 90-Minute Rated — for use on UL10B and UL10C Wood or Hollow Metal Fire Doors
- ▶ Restricts the Passage of Smoke
- ▶ Non-Handed
- ▶ Available in 36", 48", 84" and 96" Lengths
- ⓘ An NGP Strike Shim (9275 or 9225) may also be required for Proper Latchbolt Engagement
- ⓘ A Mounting Bracket (600D-28) is recommended when using Parallel Arm Closers

GAP90™

Requires installation of ALL components:
9945, 9400, 5075CL

GAP90DKB™

Requires installation of ALL components:
9945, 9400DKB, 5075B

9945 Steel Stop Extender

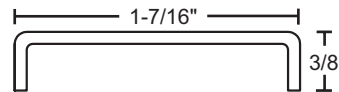

- ▶ 16-Gauge, Gray Primer Finish
- ▶ Furnished with #10 X1" TEK SMS
- ▶ Patent No.: US9,273,510B2

5075 Self-Adhesive TPE Seal

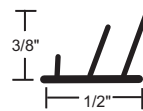

*Anti-Microbial not available in clear



5075B	BROWN
5075CL	CLEAR*

9400 NGP-Edge® Intumescent Seal with PVC Cover

- ▶ Self-Adhesive

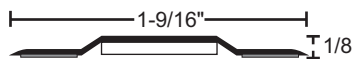

9400	GRAY
9400DKB	BROWN

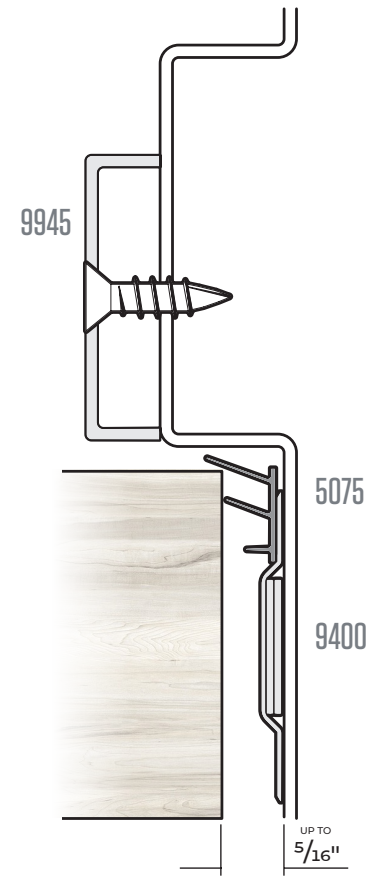

NGP-FDA-GAP-PCS-0919-A