

# 40 Series Mortise Cylinders & 34 Series Rim Cylinders

## Cylinders & Components

**SARGENT®**

**ASSA ABLOY**

### 40 Series Mortise Cylinder

- Cylinder: Solid brass, 1-5/32" (29mm) diameter
- Cap: Brass, bronze or stainless steel
- Furnished standard with No. 97 rosette and compression spring
- Optional Collars/Spacers available and ordered separately, refer to product catalogs for additional information
- See Cam Chart on Page 6 for cam required
- 6 pin standard; for 7 pin specify "7 pin", size 42 minimum
- No. 41 cylinder not available in 7 pin
- Mortise cylinder assemblies that are ordered without hardware are supplied with standard SARGENT offset cam 13-0664
- Cylinder finishes: 3, 4, 9, 10, 10B, 10BL, 15, 20D, 26, 26D, 32, 32D
- Plug finishes: 4, 15

		Length under cylinder head									
Cylinder No.		41	42	43	44	46	48	50	52	54	56
Dim. X		1-1/8" (29mm)	1-1/4" (32mm)	1-3/8" (35mm)	1-1/2" (38mm)	1-3/4" (44mm)	2" (51mm)	2-1/4" (57mm)	2-1/2" (64mm)	2-3/4" (70mm)	3" (76mm)

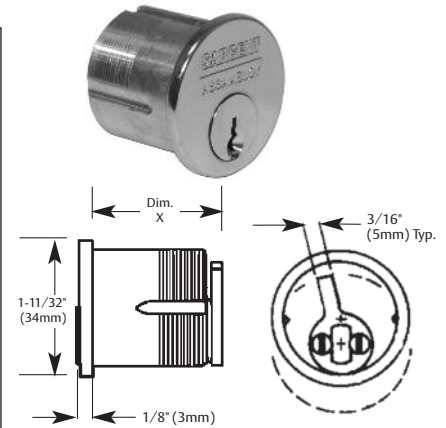

### 50-40 Series Hotel Type Cylinder

#### Features same as standard 40 Series cylinders except:

- For use with 7850 or 8250 lock only
- 6 pin only
- Contact factory for compatibility requirements for existing 6 pin systems
- Uses only cam #115 (13-2045)
- Guest and Master keys will only retract the latch bolt but not project or retract the dead bolt
- Emergency keys (catalog # 7268 EMK) retract the latchbolt and deadbolt and can also project the deadbolt
- C Series keyways supplied standard, specify if different keyway is required. On 1 bitted or KD, CA key way will be supplied if not otherwise specified
- Consult Sargent Key records dept. when adding Hotel cylinders to existing key systems for compatibility
- Length under cylinder head (Dim. X)  
50-43 1-3/8" (35mm); 50-44 1-1/2" (38mm)

### 78-40 Series Exposed Shell Only Cylinders

- Cylinder: Solid brass, 1-5/32" (29mm) diameter
- 6 pin standard, for 7 pin specify "7 pin"
- For use with SARGENT mortise locks with Escutcheon Trim (KE 3/4, LE 3/4) only
- See Function Table on Page 6 for cam required
- 78-41 6 pin; single cylinder function only except 50
- 78-42 6 or 7 pin; single cylinder functions only
- 78-43 6 or 7 pin; all functions except 50
- Plug finishes: 4, 15

### 34 Series Rim Type Cylinder

- 27/32" (21mm) screw pattern for through-bolted SARGENT exit devices
- Cylinder: Solid brass
- Cap: Brass, bronze or stainless steel
- Furnished standard with No. 97 rosette and compression spring, "break-off" screws and back plate
- 6 pin standard, for 7 pin specify "7 pin"
- Horizontal tail piece only
- Cylinder finishes: 3, 4, 9, 10, 10B, 10BL, 15, 20D, 26, 26D, 32, 32D
- Plug finishes: 4, 15

No. of Pins	Door Thickness when used with outside trim	Dim. A (Min.)	Dim. B (Min.)
6	2-3/8" to 3-1/4" (60mm to 82mm)	1-1/16" (27mm)	2-3/8" (60mm)
7	2-1/2" to 3-1/2" (64mm to 89mm)	1-7/32" (31mm)	2-3/8" (60mm)

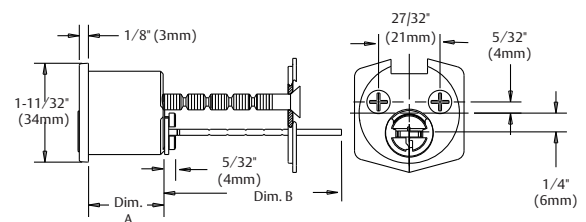

Copyright © 2006, 2008-2010, Sargent Manufacturing Company, an ASSA ABLOY Group company. All rights reserved. Reproduction in whole or in part without the express written permission of Sargent Manufacturing Company is prohibited.

All cylinders are standard 6 pin and are supplied with 2 nickel silver keys unless noted. In cylinders ordered for 5 pin systems, the (6th) last chamber will be empty.

For cylinders in competitive keyways, see Page 10.

Cylinders are supplied random keyed unless specified 1 bitted or master keyed. For master keyed orders provide keying details as requested on SARGENT Keyed Order Lead Sheets, located in the price book or contact customer service.

90622-C 11/1/10





# Cams for Mortise Cylinder and Installation Tools for 6300 & 7300 Cylinders

## Cylinders & Components





**SARGENT®**

**ASSA ABLOY**

### Cams For Conventional Mortise Cylinders\* in SARGENT Keyways









				
<b>Standard Cam</b> (13-0664)	<b>#105</b> (13-0665)	<b>22-Standard</b> (13-0662)	<b>22-105</b> (13-0663)	<b>#115</b> (13-2045)
Standard open slotted cam provided on all 40 Series - standard. Except: 16, 50 & 92 function Mortise Locks	Short cam used for 16 & 92 function locks (Inside Cylinder) (Was -3 & -8)	Cam used for Construction Key Systems (22-), except for 16 & 92 function inside cylinder & 50 function mortise locks	Cam used for Construction Key Systems (22-), 16 & 92 function mortise locks (Inside Cylinders)	Cam used for Hotel (7850/8250) function cylinders (was -2)

### Miscellaneous Cams\*

				
<b>#101</b> (13-0512)	<b>#104</b> (13-0513)	<b>#113</b> (13-0921)	<b>#106</b> (13-0938)	<b>#112</b> (13-0097)
Adams Rite 1850, 4700	Adams Rite 4070, 4350, 4250, 4516, 4150	SARGENT 4370 Series key switches	"Open" Schlage "L"	"Open" Misc.

### Cams for 6300 Large Format Interchangeable (Removable) Core Mortise Cylinders (Factory assembled to housing)

- 6300 Cams are factory installed and are not removable
- 6300 Cams are not sold separately
- Specify required Cam as a suffix: 63-44-105 cam
- For Standard Cam: No Suffix is required

	<b>Standard</b> 6300 Series Cam		<b>-105</b> Cam for 6300 Series 16 & 92 function locks
	<b>-115</b> Cam for 6300 Series 50 function locks		<b>-101</b> ADAMS RITE 1850 4710
	<b>-104</b> ADAMS RITE 4050, 4150, 4250, 4350, 4070, 4516		<b>-113</b> 4370 Series key switch
	<b>-106</b> Schlage "L"		<b>-112</b> Wide Straight

\* Two screws attach cam to cylinder, order as an 01-1121, when needed

### 432 RC 6300 Large Format Interchangeable (Removable) Core Installation Tool



### 432 IC 7300 Small Format Interchangeable Core Installation Tool



- The 432 RC and 432 IC are tools to assist in installing SARGENT Large Format Interchangeable (Removable) Core and Small Format Interchangeable Core Mortise Housings. These tools make it easy to thread a cylinder body into a Mortise lock and can also help check the cylinder function in a lock before installing the cylinder core.
- Order: 432 RC for the SARGENT Large Format Interchangeable (Removable) Core Installation Tool
- Order: 432 IC for the Small Format Interchangeable Core Install Tool

Copyright © 2006, 2008-2010, Sargent Manufacturing Company, an ASSA ABLOY Group company. All rights reserved. Reproduction in whole or in part without the express written permission of Sargent Manufacturing Company is prohibited.

90622-C 11/11/10

# Cylinders for Bored, Auxiliary, Integrallock and Mail Box Locks

## Cylinders & Components

**SARGENT®**

**ASSA ABLOY**

### 10, 7, 6500 & 7500 (Lever) Line Standard Cylinders

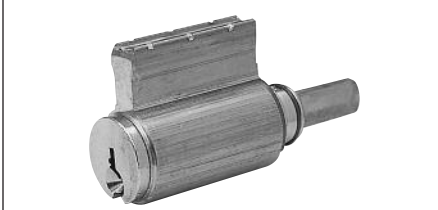

Part Numbers:

C10-1 (13-3266) for all functions (except 50)  
C10-2 (13-3492) for Hotel 50 function

### 8 and 9 Line Cylinders (Knob Locks)

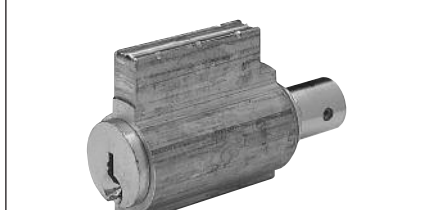

Part Numbers:

C8-1 (13-2194) for all functions (except 50)  
C8-2 (13-2195) for Hotel 50 function

### T-Zone (11 Line) Cylinder



Part Numbers:

C11-1 (13-4145) for all functions (except 50)  
C11-2 (13-4146) for Hotel 50 function

### 6 Line Cylinder

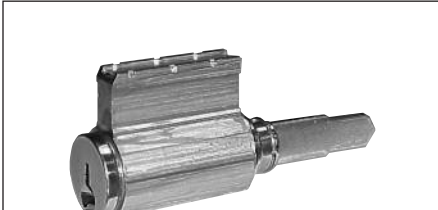

Part Numbers: Knob Function

C6-1 (13-3129)	S & N	All except 50
C6-1B (13-3130)	B	All except 50
C6-2 (13-3108)	S & N	50 Function
C6-2B (13-3109)	B	50 Function

### 4101 Mailbox Cylinder

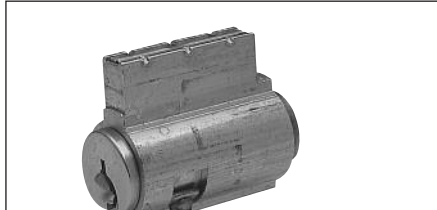

Consult mailbox manufacturer to determine compatibility of cylinder and mailbox. 5 or 6 pin systems

- 2 cut day keys provided
- US Postal regulations prohibit master keyed cylinder

### 460, 470 and 480 Deadbolt & 7500 Interconnected Deadbolt Cylinders



Part Numbers: Function

C480-1 (13-3456)	454, 474, 484
C480-2 (13-3457)	7500DB, 455, 485, 487
C480-3 (13-3458)	456, 475, 486
C460-1 (13-3495)	464
C460-2 (13-3496)	465

### 7600 Integrallock Cylinder

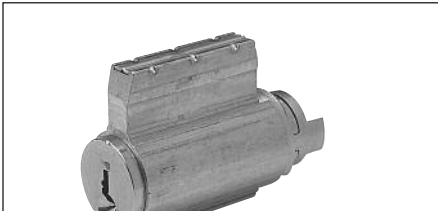

Part Number:

C7600-1 (13-3987) for all functions (except 26, 27, 50)

### 5 and 5500 Line Cylinders



Part Numbers:

C5500-1 (13-3526) for all functions (except 5 line 50)  
C5500-2 (13-3708) 5 line 50 function hotel

### 758/858 Padlock Cylinder



Part Numbers:

C-750-1 for 758/858 Padlocks  
04 Finish only

All cylinders are 6 pin and are supplied with 2 nickel silver keys unless noted. When cylinders are ordered keyed to 5 pin systems, the (6th) last chamber will be empty. Cylinder finishes: 4 and 15.

For cylinders in competitive keyways, see Page 10.

Cylinders are supplied random keyed unless specified 1 bitted or master keyed. For master keyed orders provide keying details as requested on SARGENT Keyed Order Lead Sheets, located in the price book or contact customer service.

Cylinders ordered from SARGENT Turbo program are supplied as 1 bitted as standard unless otherwise specified

Copyright © 2006, 2008-2010, Sargent Manufacturing Company, an ASSA ABLOY Group company. All rights reserved. Reproduction in whole or in part without the express written permission of Sargent Manufacturing Company is prohibited.

90622-C 11/1/10

# 6300 Series Large Format Interchangeable (Removable) Cores

## Cylinders & Components

**SARGENT®**

**ASSA ABLOY**

### 60- Prefix Disposable Plastic Core



- During the construction phase in non restricted areas, disposable plastic cores can be used, eliminating use and distribution of the actual keys
- Once construction is near completion, the permanent keyed cores will be installed and the building secured; permanent keyed cores are ordered separately as 6300 Cores
- Disposable cores are available for Mortise, Exits and most cylindrical lock sets
- Operate with coin or flat screw driver
- One piece design allows for easy installation
- To order separately: Use p/n 13-5177
- Mortise Sizes available: 60-42, 60-43, 60-44 & 60-46
- Available 6300 Mortise Cams on Pg 6
- Specify required Cam as a suffix: 60-44-105 cam
- For Standard Cam: No Suffix is required
- Plastic Cores p/n is 13-5177

### 64- Prefix Construction Keyed Large Format Interchangeable (Removable) Core Keyed Cylinders

- The SARGENT 6400 interchangeable brass construction core enables doors to be locked during project construction period
- Using 6400 cores prevents keys for the permanent key system from becoming available during the construction process
- After construction is completed, the 6400 brass cores are removed and replaced with 6300 keyed-permanent interchangeable Cores
- A special control key releases the locking sleeve of the cylinder core allowing immediate removal of the core
- Construction cores are all keyed alike in one KA keyset
- Furnished with 6 keys and 1 control as standard
- Plug face dimpled for easy identification
- Order as a 64- prefix with products
- Mortise Sizes available: 64-42, 64-43, 64-44 and 64-46
- Available 6300 Mortise Cams on Page 6
- Specify required Cam as a suffix: 64-44-105 cam
- For Standard Cam: No Suffix is required
- Order as a 64- prefix with products

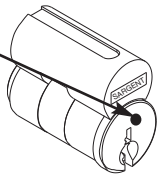

6400 Brass Core

### 6300 Permanent Large Format Interchangeable (Removable) Cores Cylinders

- SARGENT LFIC (Removable) Core Cylinders and Master Key Systems are available for a quick change of cylinders for increased security. It is not necessary to remove the lock from a door to rekey the opening
- Special "control" key is used to release a locking cam allowing immediate removal of the core
- Available for use in many SARGENT products (Exit Devices, Mortise locks, Bored locks and padlocks)
- LFIC Key Systems can also include conventional cylinders operated by the same Master/change keys when the 6300 quick change feature is not needed.
- Can be master or grand-master keyed
- 2 Change keys provided
- 6 pin standard
- 1 bitted available for field keying
- 1 bitted cylinders supplied with 2 key blanks, pins and springs in chambers in 3 and 4 only.
- HA keyway will be supplied unless otherwise specified.
- Wide variety of master key systems available
- Permanent (keyed Large Format Interchangeable) cores supplied with hardware unless specified otherwise
- Available in the following SARGENT keyway families: A, B, C, G, H, K, L, N, R, and V
- Also available in the following single key sections: CR and S
- Control key is 6272 CTL, ordered separately
- Finishes: 4, 15
- Ordering as a: 6300 LFIC Core x finish and give all keying information

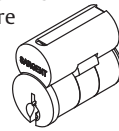

### 65-6300 Unassembled Core Only

- Unassembled core for field rekeying. Includes Control Sleeve and two key blanks
- Springs and pins to be ordered separately (see Pages 14 & 15)
- 65- Prefix - Uncombine Cores
- Finishes: 4, 15
- HA key way will be supplied standard, unless otherwise specified
- Order as: 65-6300 x finish x keyway (6 pin only)

### 6300 Series Parts Only

- 13-0795 Plug, Finishes: 4, 15
  - 13-3424 Inner Shell & Slide Assy, Finishes: 4, 15
  - 13-0796 Control Sleeve
  - 01-0660 Plug retaining ring
  - 13-0797 Slide for Cylinders with a box around the word SARGENT (Mfg prior to 4/06)
  - 13-1341 Slide for Cylinders WITHOUT a box around the word SARGENT (Mfg after 3/06)
- For pins, springs & keying kits see Pages 14 & 15.

### 63-34 Rim Cylinder

- Housing: Solid brass
- Cap: Brass, bronze or stainless steel
- Furnished standard with No. 97 rosette and compression ring
- Includes the same tailpiece and screw hole pattern as the #34 cylinder
- Finishes: 3, 4, 10, 10BL, 20D, 26, 26D, 32, 32D.
- Order as: 63-34 x Finish
- Also available: 60-34 & 64-34 Rim Cylinders

### 63-40 Series Mortise Cylinders Standard & Hotel Function Cylinders



- Cylinder: Solid brass 1-5/32" diameter
- Cap: Brass, bronze and stainless steel
- Furnished standard with No. 97 rosette and compression ring
- Optional Collars/Spacers available and ordered separately, refer to product catalogs for additional information
- HA Standard Keyway (Except Hotel)
- For hotel functions, "C" series keyway supplied standard (size #43 (1-3/8") only).
- Hotel emergency key is 7269 EMK, ordered separately
- Other SARGENT keyways available
- Mortise Sizes available: 63-42, 63-43, 63-44 & 63-46
- Available 6300 Mortise Cams on Pg 6
- Specify required Cam as a suffix: 63-44-105 cam
- For Standard Cam: No Suffix is required
- Finishes: 3, 4, 9, 10, 10B, 10BL, 15, 20D, 26, 26D, 32, 32D
- Order as: 63-42 x Finish
- 60-42 same as above, but supplied with plastic disposable plastic core

### 63-40 Series Mortise Cylinder Sizes

Cylinder #	63-42	63-43	63-44	63-46
Length	1-1/4" (32mm)	1-3/8" (35mm)	1-1/2" (38mm)	1-3/4" (44mm)

### 436-1 Slide Block Kit

- Includes fixture and staking tool for use only with the (10)- 6300 Series Cylinders manufactured after March 2006 for the ease of top loading in the field
- The kit includes 100 each slides p/n 13-1341, Staking Block and staking tool
- Cylinders manufactured after March 2006 will not include the box around the SARGENT logo and can be used with this kit

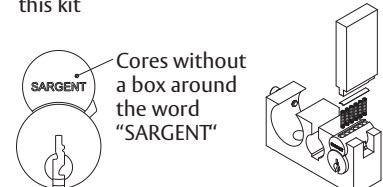

Cores without a box around the word "SARGENT"