

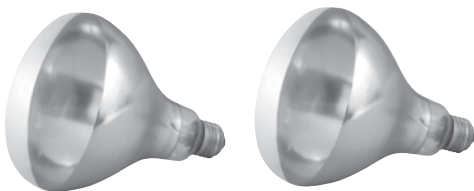

Professional Freestanding Heat Lamp for Restaurant

Operating Instruction Manual



Includes 2 Clear, Infrared
250W/120V Bulbs



EHL-2



Item No.	Power Rate	Voltage	Dimensions (H x W x D)	Feature
EHL -2	500W (2 Bulb) (250W each bulb)	120V~60Hz	23.25" x 14.0" x 15.75" 591mm x 35.6mm x 400mm	Heavy duty 14Ga Aluminum; 6 ft. Long Cord

BEFORE OPERATING ANY EQUIPMENT, READ AND FAMILIARIZE YOURSELF WITH THESE USE AND SAFETY INSTRUCTIONS

Congratulations on your purchase of this WINCO® commercial equipment. When used as intended and with proper care and maintenance, you are sure to experience years of reliable operation from this equipment. To ensure best results, it is important that you read and follow the instructions in this manual carefully. **It is important to keep these instructions in a safe place for future reference.**

Professional Freestanding Heat Lamp

Important For Future Reference

Please complete this information and retain this manual for the life of the product. For Warranty Service and/or parts, this information is required. Please see Page 8 for More information on your Warranty and how to register.

EHL-2

Model Number

Serial Number

Date Purchased



WARNING: IMPROPER INSTALLATION, ADJUSTMENT, ALTERATION, SERVICE OR MAINTENANCE CAN CAUSE PROPERTY DAMAGE, INJURY, OR DEATH. READ THE INSTALLATION, OPERATION, AND MAINTENANCE INSTRUCTIONS THOROUGHLY BEFORE INSTALLING OR SERVICING THIS EQUIPMENT.

AVERTISSEMENT: TOUTE INSTALLATION, RÉGLAGE, MODIFICATION, RÉPARATION OU ENTRETIEN INCORRECT PEUT OCCASIONNER DES DOMMAGES MATÉRIELS, DES BLESSURES GRAVES OU LA MORT. LIRE LES INTRUCTIONS D'INSTALLATION, D'UTILISATION ET D'ENTRETIEN ATTENTIVEMENT AVANT D'INSTALLER OU DE RÉPARER CET APPAREIL.



CAUTION: THESE MODELS ARE DESIGNED, BUILT, AND SOLD FOR COMMERCIAL USE ONLY. IF THESE MODELS ARE POSITIONED SO THE GENERAL PUBLIC CAN USE THE EQUIPMENT, MAKE SURE THAT CAUTION SIGNS, WARNINGS, AND OPERATING INSTRUCTIONS ARE CLEARLY POSTED NEAR EACH UNIT SO THAT ANYONE USING THE EQUIPMENT WILL USE IT CORRECTLY AND NOT INJURE THEMSELVES OR HARM THE EQUIPMENT.

ATTENTION: CES MODÈLES SONT CONÇUS, FABRIQUÉS, ET VENDUS POUR UN USAGE COMMERCIAL SEULEMENT. SI CES MODÈLES SONT PLACÉS POUR QUE LE GRAND PUBLIC PUISSE LES UTILISER, ASSUREZ-VOUS QUE LES CONSIGNES D'ATTENTION, D'AVERTISSEMENT, ET LES INSTRUCTIONS D'UTILISATION SOIENT CLAIEMENT AFFICHÉES PRÈS DE CHAQUE UNITÉ DE SORTE QUE N'IMPORTE QUEL UTILISATEUR DE L'APPAREIL L'EMPLOIE CORRECTEMENT ET NE SE BLESSE PAS OU N'ENDOMMAGE PAS L'APPAREIL.



WARNING: A FACTORY AUTHORIZED SERVICE PROVIDER SHOULD HANDLE ALL MAINTENANCE AND REPAIR. BEFORE DOING ANY MAINTENANCE OR REPAIR, ARRANGE FOR SERVICE.

AVERTISSEMENT: UN TECHNICIEN AUTORISÉ PAR L'USINE DEVRA EFFECTUER TOUT L'ENTRETIEN ET LES RÉPARATIONS. AVANT DE FAIRE TOUT ENTRETIEN OU RÉPARATION, VEUILLEZ CONTACTER WINCO.



Introduction

Congratulations on the purchase of your WINCO® countertop appliance. Please take time to carefully read through this manual to ensure the machine is operated and maintained properly, to ensure the best possible performance from the product for many years.

WINCO will not accept liability for the following if:

- The instructions in this manual have not been followed correctly.
- Non-authorized personnel have tampered with the machine.
- Non-original spare parts are used.
- The machine has not been handled and cleaned correctly.
- There is any use damage to the unit.

Professional Freestanding Heat Lamp

Table of Contents	
Specifications.....	1
Package Contents	3
Unpacking the Equipment	4
Function and Purpose	4
Warning Labels.....	4
Installation Guidelines	4
Safety Precautions	5
Features	6
Operation	6
Cleaning the Unit	6
Troubleshooting.....	7
Service & Repair	7
Warranty	8

Package Contents

All units come with an Operating Instruction Manual and the following:

- EHL-2 unit
- 2 clear, infrared bulbs - 500W (250W ea), 120V

WINCO® prides itself on quality and service, ensuring that at the time of packing, all products are supplied fully functional and free of damage. Should you find any damage as result of freight, please contact your WINCO® dealer immediately.

To ensure safe installation and operation, please carefully read and understand the following statements.

Unless the operator is adequately trained and supervised there is a possibility of injury. Owners of this equipment are responsible to make certain that this equipment is used properly and safely, and that all of the instructions contained in this manual are followed. Adherence to the requirements of local, state or federal law is required.

Owners should not permit anyone to use this equipment unless they are over 18 years old, adequately trained, supervised, and have read and understood this manual.

Owners should also ensure that no customers, visitors or other unauthorized personnel come in contact with this equipment. It is the responsibility of the owner and the operator to remain alert to any hazards posed by the function of this equipment.

If an operator is ever uncertain about a particular task or the proper method of using this equipment, they should ask an experienced supervisor.

Unpacking the Equipment

DISPOSE OF ALL PACKAGING MATERIALS IN AN ENVIRONMENTALLY RESPONSIBLE MANNER.

1. Remove all packing materials and tape, as well as any protective plastic and cardboard, from the unit.
2. Clean any glue residue left over from the plastic or tape.
3. Place the unit in the desired position and height.

SAVE THE ORIGINAL BOX AND PACKAGING FOR USE IN PACKAGING AND SHIPPING THE EQUIPMENT IF SERVICES ARE NEEDED.

Function and Purpose

This unit is intended to be used in commercial foodservice operations only. It is not intended for household, industrial or laboratory use.

Before using this equipment all surfaces should be cleaned and **dried thoroughly**. Failure to clean surfaces before using the unit could cause food contamination.

Warning Labels

This manual contains a number of precautions to follow to help promote safe use of this equipment. Throughout the manual you will see additional warnings to help alert you to potential hazards.

Warnings affecting your personal safety are indicated by:



Warnings related to possible damage to equipment are indicated by:



WARNING



CAUTION

NOTE

NOTE is used to notify users of installation, operation, or maintenance information that is important but not hazard-related.

Please remember that this manual and the warning labels do not replace the need to be alert, to properly train and supervise operators, and to use common sense when using this equipment.

Installation Guidelines

These precautions should be followed at all times. Failure to follow these precautions could result in injury to yourself and others.

TO REDUCE RISK OF INJURY OR DAMAGE TO THE UNIT:

1. Read this manual thoroughly before installation and operation. DO NOT proceed with installation and operation if you have any questions or do not understand anything in this manual. Contact your representative or the manufacturer first.
2. Remove the unit and bulbs from the box. Once your unit has been removed from the packaging, be certain that all protective plastics and residues are removed from all surfaces.
3. Select a location for the unit that has a level, solid, non-skid surface that is nonflammable and away from water hazards or sinks, and is in a well-lit work area.
4. Inspect the unit to ensure all parts have been provided.
5. Proper connections and power supply are essential for efficient performance.

Proper Grounding

This machine is provided with a three-pronged grounding plug. The outlet to which this plug is connected must be properly grounded. If the receptacle is not the proper grounding type, contact an electrician. DO NOT, under any circumstances, cut or remove the third ground prong from the power cord or use any adapter plug.

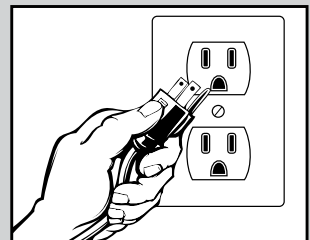

**USE A GROUNDED OUTLET
DO NOT ADD AN ADAPTOR
TO THE PLUG**

6. When using electrical appliances, basic precautions must always be followed to reduce the risk of fire, electric shock and injury.
7. Clean this appliance thoroughly before and after each use. Refer to cleaning instructions on page 9.



WARNING

Plug heat lamp into grounded outlet with correct voltage and sufficient power capacity. Refer to Product Identification label on the warmer for voltage and wattage requirements. The heat lamp is designed for use on alternating current (AC) only.

Safety Precautions



CAUTION

This equipment gets HOT. Make sure all flammable/combustible materials are set away from this equipment.

TO AVOID SERIOUS PERSONAL INJURY

1. **DO NOT** operate the unit before reading the instruction manual first.
2. **ALWAYS** disconnect or unplug electrical power before cleaning, servicing or adjusting any parts or attachments.
3. **NEVER** bypass, alter or modify this equipment in any way from its original condition. Doing so may create hazards and will void warranty.
4. **NEVER** operate the unit with a damaged power cord or plug.
5. **NEVER** leave the unit on overnight.
6. **NEVER** use the unit as a heating source for your kitchen, space, or room.



CAUTION

IMPORTANT SAFEGUARDS & SAFETY INSTRUCTIONS
When using electrical food equipment, basic safety precautions should always be followed.

7. **DO NOT** touch hot surfaces. This appliance is Hot when in use. To avoid burns, do not let bare skin touch hot surfaces.
8. **CAUTION:** To protect against risk of electrical shock, do not immerse in water, dishwasher or any other liquid.
9. **ALWAYS** unplug unit when not in use, before putting on or taking off parts, and before cleaning.
10. **CAUTION:** The use of attachments not recommended or sold by the manufacturer may cause fire, electrical shock or injury.
11. **DO NOT** use outdoors.
12. **DO NOT** place on or near a hot gas or electric burner, or in a heated oven. Keep combustible materials such as drapes and other furnishings, away from appliance.
13. **DO NOT** use this equipment for any use other than the use intended by the manufacturer.
14. **DO NOT** pull by the cord to disconnect.

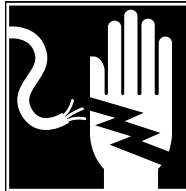

WARNING

Electrical Shock Hazard.

Keep water and other liquids from entering the inside of the unit. Liquid inside the unit could cause an electrical shock.

Do not spray water or cleaning products. Liquid could contact the electrical components and cause a short circuit or an electrical shock. Do not use unit if power cord is damaged or has been modified.

15. **NEVER** plug equipment in where water floods the area.
16. **ALWAYS** place the appliance on a firm, stable surface.



CAUTION

Extreme caution is necessary when any appliance is used by or near children or when the appliance is left unattended.



WARNING

Burn Hazard.

The unit lamp surfaces become HOT during use. Extreme caution is necessary when the appliance is left unattended.

USE CAUTION WHEN TOUCHING THE UNIT.

17. **ALWAYS** unplug appliance when not in use and before cleaning, adjusting, or maintaining this product. To disconnect this appliance, turn switch off and remove plug from power source.
18. **ALWAYS** allow the unit to cool down to room temperature after use and before dismantling for cleaning; the unit will be too hot to handle immediately after use.

Features: EHL-2

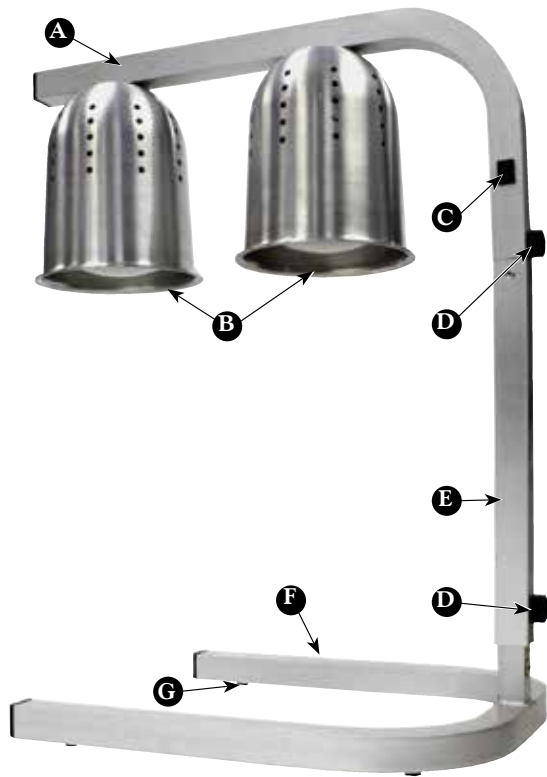

- A LAMP BAR** Mounting bar for lamp housing.
- B LAMP HOUSING** Housing for heat lamps
- C POWER ON/OFF SWITCHES** Turns power to the unit on/off.
- D LOCKING NUT** Locks the adjustable main bar in place to keep heat lamps at optimal height.
- E MAIN BAR** Raises and lowers height of lamp bar.
- F LAMP BASE**
Wide stance for stability. Standard food trays will fit between base.
- G RUBBER FEET**
Prevents unit from slipping.

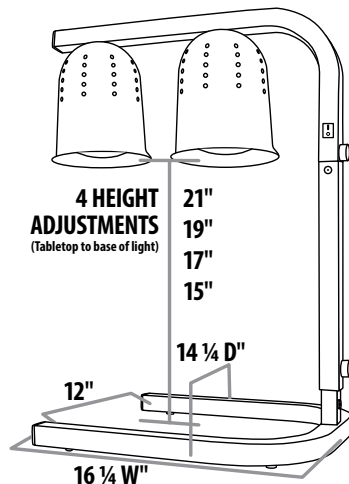

Dimensions and Height Adjustments

Preparation

1. Set unit on a flat surface.
2. Install bulbs with the specified wattage rating as indicated on the warmer.
3. If unit fails to work properly when first operated, Call Winco customer service @ 1-888-946-2682 or 1-973-916-9958

Operation

BEFORE OPERATING UNIT, ENSURE THAT THE UNIT IS ON A STURDY, LEVEL SURFACE.

1. Plug cord into grounded electrical outlet of the correct voltage. Electrical shock can occur if appliance is not grounded.
2. Place food products in a pan, located directly under the bulbs for best results.
3. Turn unit off when not in use.
4. To disconnect appliance, turn switch off and remove plug from power source.

Cleaning

NOTE

Proper maintenance plays an important part in the life span and functioning of the heat lamp.

1. Unplug the cord and let heat lamp cool before cleaning or moving.
2. This unit can be cleaned with a damp sponge and mild soap. Rinse with clean water and wipe dry.
3. Do not immerse in water or other liquid. Do not clean with a water jet.

Troubleshooting

If your WINCO® Heat Lamp does not operate, please check the following before placing a service call:

ISSUE	MIGHT BE CAUSED BY	RECOMMENDED SOLUTION
Lamps are not on	Unit is not plugged in	Make sure unit is plugged in, and power cord is not broken or damaged
	Power switch is off	Make sure power switch is in the ON position
	Bulb(s) are not screwed in	Screw in each bulb - DO NOT over-tighten, this may damage the bulb(s)
	Bulb(s) are burnt out/broken	Replace the bulb(s)
Lamps are not heating food	Wrong bulb(s)	Install 250W HEAT LAMP BULBS Only, not regular light bulbs
Lamps burn out often	Over tightening the bulb(s)	Over tightening the bulbs may cause damage that will decrease the lifespan of the bulb.
	Bulb(s) are not tight enough	If the bulb is not in full contact with the screw shell and socket, it will cause electrical arcing and pitting of the contact surface, decreasing the lifespan of the bulb.

Safety

A WINCO® Approved Service Technician should carry out repairs if necessary. Do not remove any components on this product.

If the power cord is damaged, it must be replaced by a WINCO Approved Service Technician in order to avoid a hazard.

Service and Repair

To avoid serious injury or damage, **NEVER** attempt to repair the unit or replace a damaged power cord yourself.

To initiate warranty service contact: support@wincous.com or call: 973-295-3899

DO NOT send unit to WINCO® without first contacting customer service.

See "Limited Warranty" section on page 8 for more details.

Limited warranty does not cover the EHL-BR or EHL-BW bulbs.

Limited Warranty

WINCO® warrants to the original purchaser of new equipment that said equipment, when installed in accordance with our instructions within North America and subjected to normal use, is free from defects in material or workmanship for a period of 1 year. The labor warranty is one year from original installation or 18 months from actual factory shipment date, whichever date occurs first.

THIS WARRANTY IS IN LIEU OF ALL OTHER WARRANTIES, WHETHER EXPRESSED OR IMPLIED. WINCO EXPRESSLY DISCLAIMS ANY IMPLIED WARRANTY OF MERCHANTABILITY OR EXPRESSED OR IMPLIED WARRANTY OF FITNESS FOR A PARTICULAR PURPOSE.

WINCO'S OBLIGATION AND LIABILITY UNDER THIS WARRANTY IS EXPRESSLY LIMITED TO REPAIRING AND REPLACING EQUIPMENT THAT PROVES TO BE DEFECTIVE IN MATERIAL OR WORKMANSHIP WITHIN THE APPLICABLE WARRANTY PERIOD.

IN NO EVENT SHALL WINCO BE LIABLE FOR INCIDENTAL OR CONSEQUENTIAL DAMAGES TO BUYER OR ANY THIRD PARTY, INCLUDING, WITHOUT LIMITATION, LOSS OF PROPERTY, PERSONAL INJURY, LOSS OF BUSINESS OR PROFITS OR OTHER ECONOMIC LOSSES, OR STATUTORY OR EXEMPLARY DAMAGES, WHETHER IN NEGLIGENCE, WARRANTY, STRICT LIABILITY, OR OTHERWISE.

This warranty is given only to the first purchaser from a retail dealer. No warranty is given to subsequent transferees.

Warranty does not cover product failures caused by: failure to maintain, neglect, abuse, damage due to excess water, fire, normal wear, improper set up and use. Periodic maintenance is not covered.

This warranty is not in force until such time as a properly completed and digitally signed Installation/Warranty Registration has been received by WINCO within 30 days from the date of installation.

WARRANTY SERVICE

To initiate warranty service contact: support@wincous.com
or call: 973-295-3899

DO NOT send unit to WINCO without first contacting our customer service department.

REGISTER ONLINE AT:

<http://support.wincous.com>

Proof of purchase is required to extend warranty more than 1 year from date of shipment from the factory.

THE FOREGOING WARRANTY PROVISIONS ARE A COMPLETE AND EXCLUSIVE STATEMENT BETWEEN THE BUYER AND SELLER. WINCO NEITHER ASSUMES NOR AUTHORIZES ANY PERSONS TO ASSUME FOR IT ANY OTHER OBLIGATION OR LIABILITY IN CONNECTION WITH SAID EQUIPMENT.

Examples of items not covered under warranty, but not limited to just these items:

1. Acts of God, fire, water damage, burglary, accident, theft.
2. Freight damage.
3. Improper installation or alteration of equipment.
4. Use of generic or after market parts.
5. Repairs made by anyone other than a WINCO designated service provider.
6. Lubrication.
7. Expendable wear parts, adjustable feet, blown fuses, lamps, etc.
8. Cleaning of equipment.
9. Misuse or abuse.

WARRANTY REGISTRATION

SCAN THE QR CODE WITH YOUR MOBILE DEVICE



or go to

<http://support.wincous.com>

TO FILL OUT AND SUBMIT YOUR WARRANTY REGISTRATION.

~ Keep this manual in a safe place for future reference ~