

# AMERICAN RANGE®

A  Company

Project \_\_\_\_\_

Item # \_\_\_\_\_

Quantity \_\_\_\_\_

## GAS CONVECTION OVEN

GAS TYPE:  NATURAL  LP



M-1

M-2

### STANDARD FEATURES

- Bakery depth models 90,000 BTU/hr. total heat output per oven
- All stainless steel front, sides and top
- 50/50 dependant double door, swings open 135°, one handed operation opens and closes both doors simultaneously
- Door options:
  - Two glass doors (GG)
  - Glass door, right (GL)
  - Glass door, left (GR)
  - Two solid doors (SS)
- Porcelainized oven interior for easy cleaning
- Five chrome racks with 12 position chrome rack guides
- Oven cavity accommodates a full size sheet pan side-to-side on bakery depth models
- Electronic spark igniter
- 1/2 H.P. two speed oven blower motor with maximum of 9 amp draw. Includes 6 foot power cord
- Oven cool switch for rapid cool down
- Burner "on" light
- 1 hour timer
- Thermostat control from 200°F to 500°F (93°C to 260°C)

### OPTIONAL FEATURES

- Cooling / storage racks (5 racks with 2 support guides single oven only)
- 208/240 V motor and/or transformer
- Direct vent adapter
- Heavy duty swivel casters



**Model Shown M-1GG**  
(Bakery Depth)

*Shown with optional casters and adjustable cooling / storage rack.*

### DESCRIPTION

**American Range, model M-1 single or M-2 double, standard depth convection oven** with 90,000 BTU/hr., temperature range from 200°F to 500°F. A half horsepower fan offers low and high speed fan options for baking and roasting. Porcelainized oven cavity includes a 12 position rack guide to accommodate five chrome racks which will hold 18" x 26" sheet pans horizontally or 12" x 20" hotel pans one per rack. The oven includes a 1 hour timer and a cool down mode. Stainless steel doors with a glass window or a solid door swing 135° for easy one handed operation



DESIGNED & BUILT IN USA  
PROFESSIONAL COOKING EQUIPMENT

A70390 RevA 04042023

# AMERICAN RANGE®

A  Company

13592 Desmond St Pacoima CA 91331  
T. 818.897.0808 Toll Free: 888.753.9898  
[www.AmericanRange.com](http://www.AmericanRange.com)

# MAJESTIC GAS BAKERY DEPTH CONVECTION OVEN

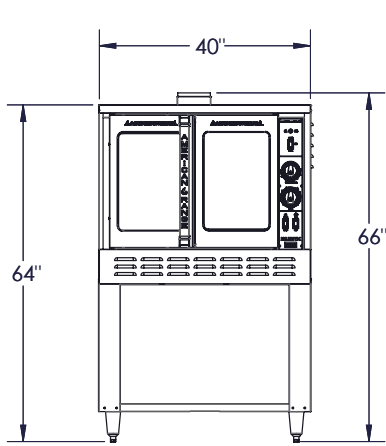

M-1 FRONT VIEW

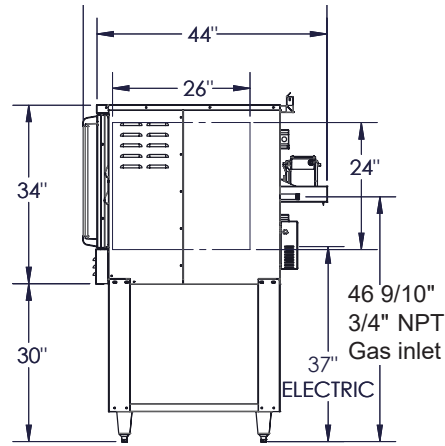

SIDE VIEW

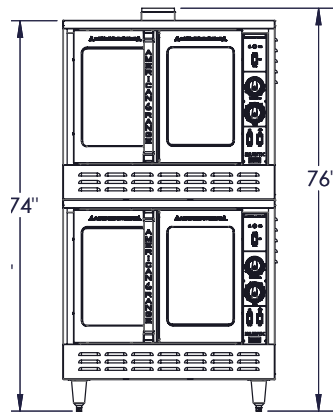

M-2 FRONT VIEW

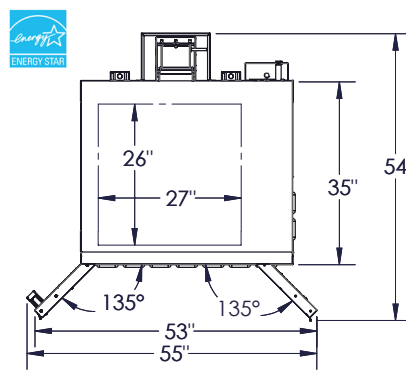

TOP VIEW

MODEL	WIDTH (MM)	DEPTH (MM)	HEIGHT (MM)	BTU	(KW)	BURNERS	Ship Weight*	
							LBS	(KG)
M-1	40" (1016)	46" (1169)	66" (1626)	90,000	(26)	2	640	(291)
M-2	40" (1016)	46" (1169)	76" (1931)	180,000	(52)	4	1280	(582)

Add two letter code to model number for door preference  
 Door options: GG- Two glass doors, GR- Glass door, right, GL- Glass door, left

### Installation Instructions:

Ovens must be installed in accordance with local codes or in their absence with the

1. National Fuel Gas Code: ANSI Z223.1; CAN/CGA-B149.1 Natural Fuel and Propane Installation Code, as applicable. Compliance with codes is the responsibility of the Owner and Installer.
2. An adequate ventilation system is required. Refer to National Fire Protection Association Standard No. 96, Standard for Ventilation Control and Fire Protection of Commercial Cooking Operations
3. This appliance is intended for commercial use. NOT intended for Residential Use.
4. Specify installation elevation if above 2000 feet (610m)
5. Please specify gas type when ordering
6. GAS INLET SIZE (All Models): One 3/4" NPT gas connections provided at rear. One 3/4" NPT gas pressure regulators are provided and must be installed (by others) when unit is connected to gas supply.
7. COMBUSTIBLE WALL CLEARANCES:  
 For use only on non-combustible floors. Legs or casters are required, or 2" (51) overhang is required when curb mounted. Clearance from non-combustible walls is 0". When unit is placed next to combustible walls, clearances must exceed 12" (305) from sides, and 4" (102) from rear.

CONVECTION OVEN ELECTRICAL		
VOLTAGE	PHASE	AMPS
120	1	4

MANIFOLD PRESSURE		
NATURAL GAS	PROPANE GAS	MANIFOLD SIZE
5.0" W.C.	10.0" W.C.	3/4" (19MM)

NMFCCODE: 25970-2 Class: 85

\*Shipping weight includes packaging and is approximate.

15 amps three prong cord provided



13592 Desmond St Pacoima CA 91331  
 T. 818.897.0808 Toll Free: 888.753.9898  
 www.AmericanRange.com