

AMERICAN RANGE®

A  Company

Project _____

Item # _____

Quantity _____

AF-DS FRYER DUMP STATION



AF-DS

STANDARD FEATURES

- All stainless steel front and sides.
- 10 gauge all welded body construction.
- 6" legs or optional casters.
- 304 stainless steel support throughout the unit.
- Two year limited warranty, parts and labor.

AVAILABLE OPTIONS

- Four casters front two with locking brakes.
- Stainless steel Splash Guard (easily removable without tools).
- Joiner Strip: Connects two fryers and prevents oil from getting in between the fryers or drain station.



Model Shown AF-DS

Shown with optional casters



A70194 RevC 11012023

AMERICAN RANGE®

A  Company

13592 Desmond St Pacoima CA 91331
T. 818.897.0808 Toll Free: 888.753.9898
www.AmericanRange.com

AF-DS FRYER DUMP STATION WITH STORAGE

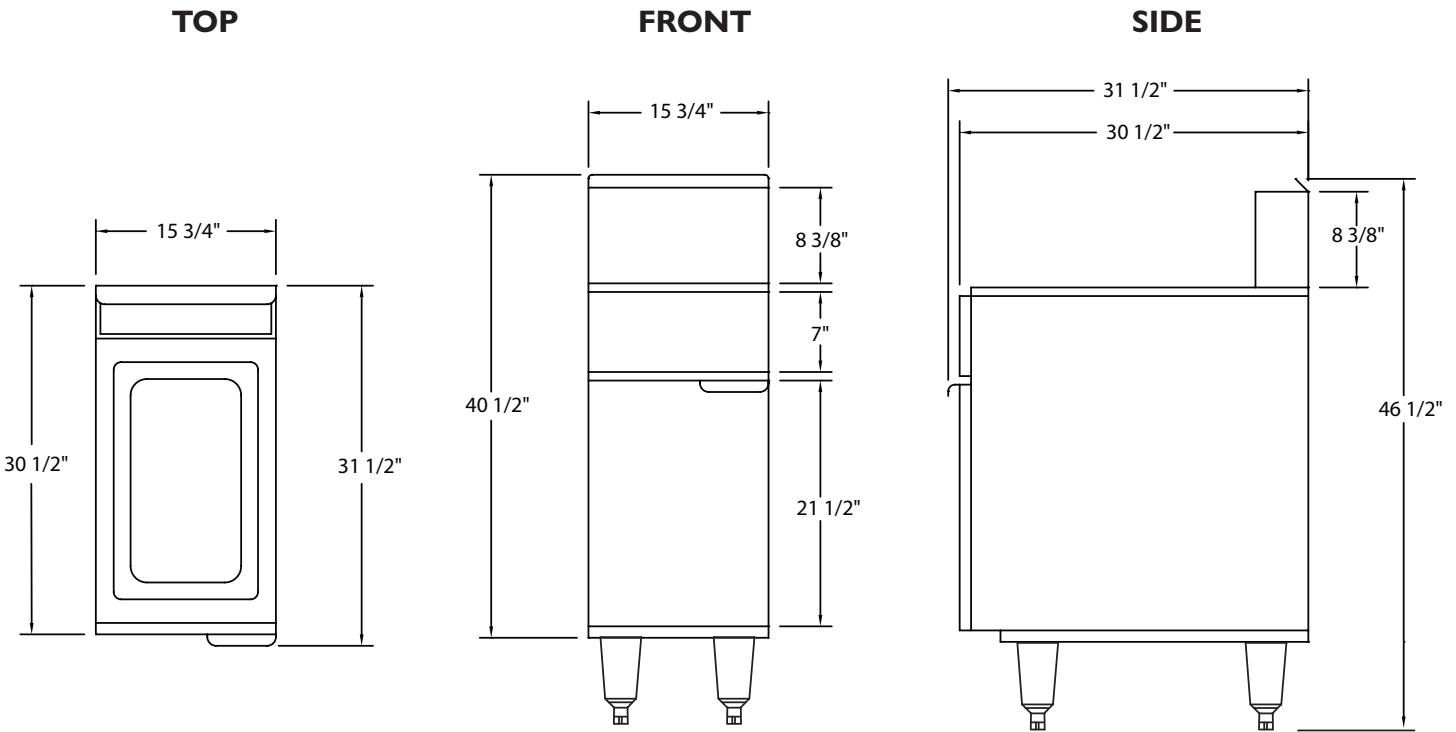

Shipping Weight*

| MODEL | WIDTH (MM) | DEPTH (MM) | HEIGHT (MM) | BURNERS | DRAIN AREA | BTU | (kW) | LBS | (KG) |
|-------|------------------|------------------|-------------------|---------|---|-----|------|-----|------|
| AF-DS | 15 3/4" (400 mm) | 30-1/2" (800 mm) | 46-1/2" (1181 mm) | 2 | (1) 12 3/4" x 20" x 4" (222 mm x 356 mm) | NA | NA | 95 | (43) |

Specify type of gas and altitude if over 2000 feet.

Please specify gas type when ordering.

American Range is a quality manufacturer of commercial cooking equipment. Due to continuing product improvements, these specifications are subject to change without prior notice.

NMFCCODE: 25970-2 Class: 85

*Shipping weight includes packaging and is approximate.

DESIGNED & BUILT IN USA
PROFESSIONAL COOKING EQUIPMENT



AMERICAN RANGE
A **Hatco** Company

13592 Desmond St Pacoima CA 91331
T. 818.897.0808 Toll Free: 888.753.9898
www.AmericanRange.com