

PLUS Crescent Grab Bar

Curved Support Rail

Technical Data Sheet

Product Specification

The product shall be a grab bar with a curved handle. The product shall have flange covers that conceal the mounting hardware. All components of the product shall be constructed of #304 stainless steel, suitable for use in wet environments. The grab rail portion of the product shall be 1.25" / 3.2cm in diameter. The product shall have a weight capacity of 500lbs / 227kg. Product shall comply with ADA Guidelines, specifying the structural strength of grab bars, tubs and shower seats. The grab rail shall be HealthCraft model PLUS-CGB-____ (see table below for appropriate product code).



Key Features

- Elegant Design with Integrated Support
- Solid Construction and Mounting
- Suitable For Use in a Wet Environment
- 500lbs / 227kg Weight Capacity

Codes and Standards

- ADA 609.2 Cross Section
- ADA 609.3 Spacing
- ADA 609.8 Structural Strength



Specified Model

| Model | Finish | Material |
|--------------|-----------------|----------------------|
| PLUS-CGB-BLK | Matte Black | #304 Stainless Steel |
| PLUS-CGB-BS | Brushed | |
| PLUS-CGB-CP | Polished Chrome | |

PLUS Crescent Grab Bar

Curved Support Rail

Technical Data Sheet

Product Dimensions

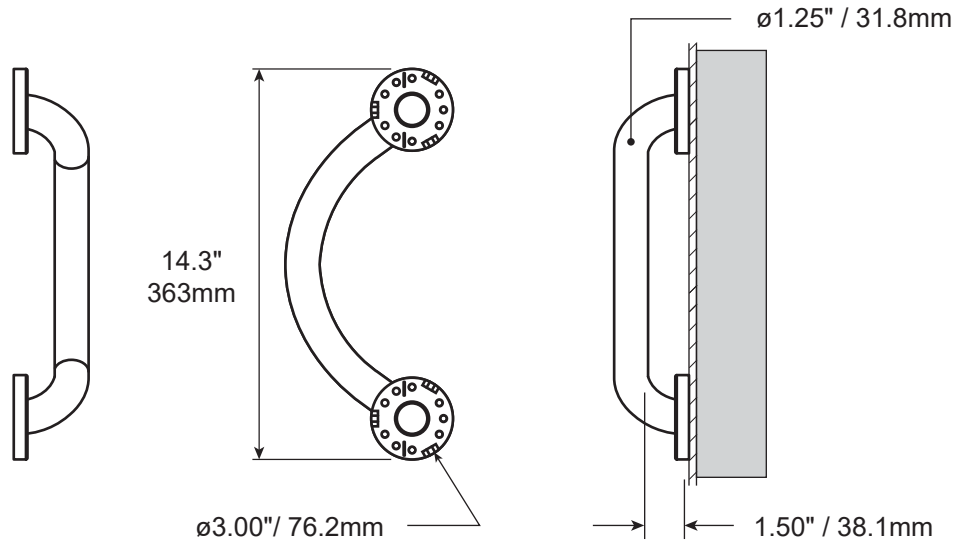

Shipping Dimensions

| Model | Height (H) | Width (W) | Depth (D) | Weight |
|-------|---------------|----------------|----------------|------------------|
| CGB | 3.15" / 8.0cm | 15.2" / 38.5cm | 7.28" / 18.5cm | 1.20lbs / 0.54kg |

