

# FLIP TRAP

## INSTALLATION INSTRUCTIONS

### Flip Trap

#### PARTS

- 2 – wood bars, one with through holes
- 2 – metal rods
- 1 – trap cloth

#### TOOLS NEEDED

hammer or mallet

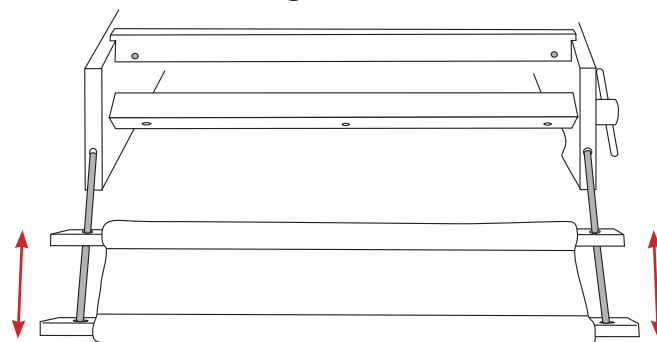
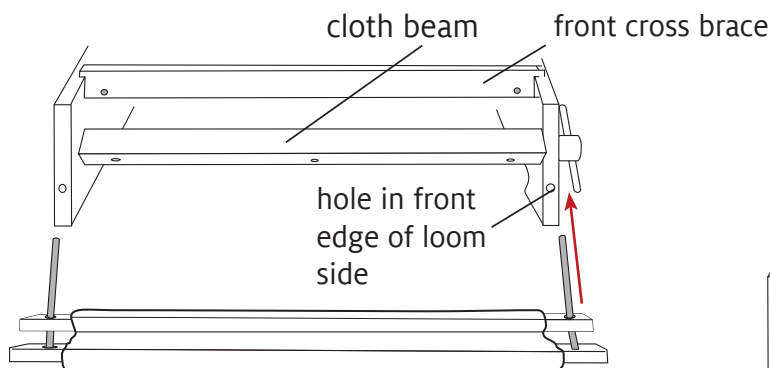
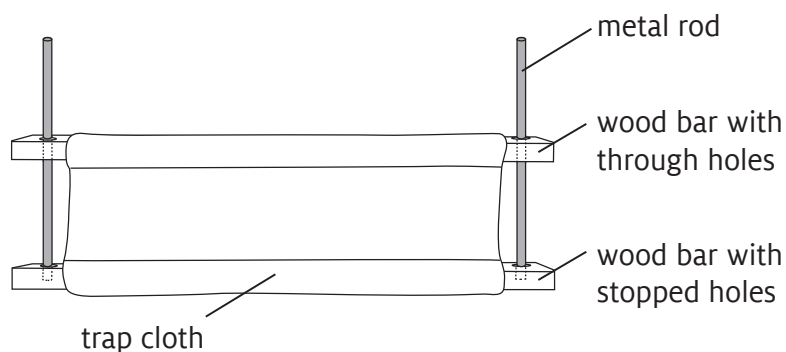

### Assembly

1. Slide the wood bars through the sleeves in the long sides of the trap cloth.
2. Push the metal rods **through** the holes in the first wood bar, then **into** the stopped holes of the second.
3. Squeeze the two wooden bars together so that most of the metal rods are pushed through.
4. Insert the free ends of the metal rods into the holes in the front of the Flip loom sides.
5. Push metal rods into place (or gently tap with a hammer or mallet).
6. Extend the first wood bar up along the metal rods until the trap cloth is pulled taut.



Find out more at [schachtspindle.com](http://schachtspindle.com)  
Schacht Spindle Company 6101 Ben Place Boulder, CO 80301  
p. 303.442.3212 f. 303.447.9273

© 2017 Schacht Spindle Company, Inc.