



SERDI

4.5

Very accurate, all-purpose machine to ream the guides and cut the valve seats. Triple air-float patented centering system and powerful spindle with built-in motor.

Highly versatile machine producing an accurate machining of the valve seats from the smallest to the biggest diameter. This machine can repair any existing engine, from the micro-engine up to the big stationary engine. The light-weight floating assembly can machine cylinder heads with guide diameters as small as 4 mm (0.16").



Machining capacity from 16mm to 120mm / 0.6" to 4.72".

Patented lightweight workhead : built-in spindle motor and triple air-float centering system. Minimal workhead inertia and maximum floatation for unmatched centering sensitivity.

Mechanical clamping of the work head on the machine bed with pneumatic clamping jack and vacuum system.

Fully integrated spindle motor, variable speed from 40 to 840 RPM, paired to a 2.2 kW Siemens inverter. Digital spindle speed rotation and depth read out.

Modern modular machine bed made of iron cast, designed for improved rigidity.

Computer enhanced static and dynamic characteristics provide the latest in machining technology.

Fully pneumatic and electric machine.

Fitted with the new SERDI tooling that decreases the cutting force by 30%, this machine will cut the hardest seats.

Patent U.S.A. N° 5,769,576
European Patent N° 0833711

www.SERDI.com

SERVICE QUALITY RELIABILITY

World Class Technology



SERDI

SPINDLE SPECIFICATIONS



A 2.2 KW built-in motor-spindle with maximum torque from 40 to 385 rpm and a maximum speed of 840 rpm.

Stator cooled by heat sink

Rigid heavy duty motorspindle of 3.15 in (80 mm) diameter for machining without chatter.

Get the best machining accuracy thanks to a high precision tooth rack and a whole spindle assembly rigid and concentric to the valve guide.

MOTOR SPINDLE TORQUE CURVE

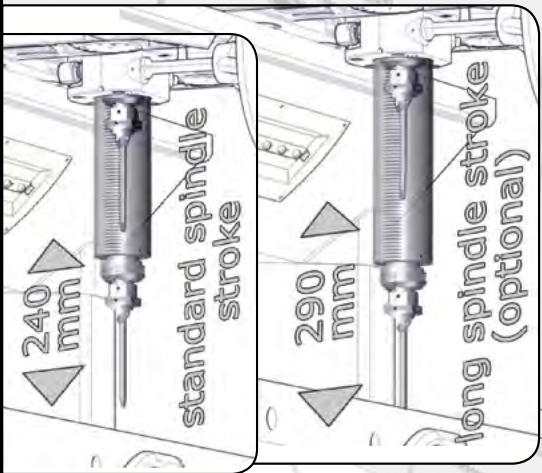
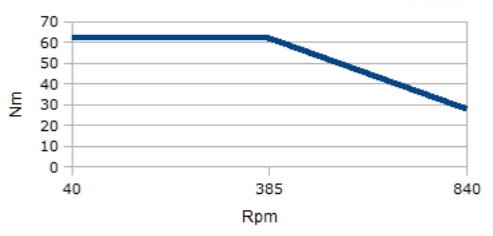

TRIPLE

Our triple air cu
spindle decreas
floating parts w
which improve

It does automa
guide regardle
or angular de
pilot

LED LIGHTNING

The machining head and beam are both equipped with LED lightning for an increased lighth ratio and a better energy saving.



PARKING AREA

This extra length on the beam (optional) is available to ease the mounting and unmounting of large and heavy cylinder heads on the floating table.

TOOL SHARPENER

Diamond wheel cutting bit sharpener

INTEGRATED VACUUM TESTER

For a fast valve sealing check before removing the cylinder head.

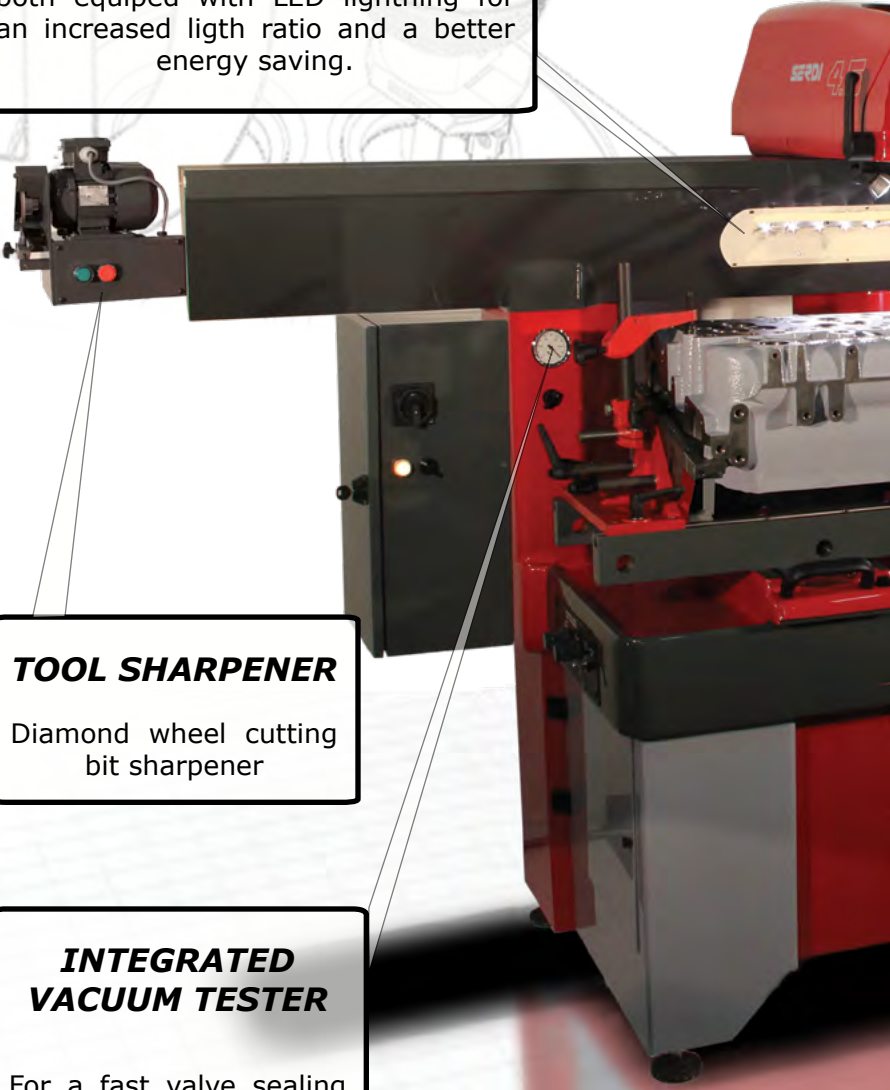

AIR CUSHION

...shion and built-in motor
...es dramatically the free
...weight during centering
...es speed and accuracy.

...tically align each valve
...ss of any misalignment
...flection thanks to live
...t technology.

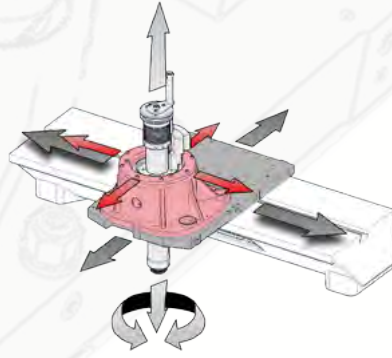

CONTROL PANEL



Spindle control buttons located just behind the handwheel to change with ease the spindle speed rotation, switch spindle direction or reset the depth control measurement.

Digital depth control accurate until 0.0004 in (0.01 mm).

Two switch buttons to fastly enable both sphere and cylinder cushions, or lock them.

Large handwheel for a better control of machining depth.

AIR FLOATING SUPPORT TABLE



Cylinder heads up to 350 kgs can be moved back and forth without any effort and then locked by two powerful pneumatic jacks.

Applications:

Heavy diesel:



Stationary engines:



Marine:



Racing:



Motorcycle:



Automotive:



4.5

TECHNICAL FEATURES

Space requirements

Length (standard)	mm / inch	2000/68.9
- with optional parking area	mm/inch	2200/86
Width	mm / inch	1150/45.3
Height	mm / inch	2320/91.4

Max cylinder head dimensions

Length	mm / inch	unlimited
Width	mm / inch	500/19.7
Height	mm / inch	475/18.7

Table travel

	mm/inch	160/6.7
--	---------	---------

Machining capacity Ø min - max

	mm	16 to 120
	inch	0.6 to 4.73

Workhead travel

Lengthwise (standard)	mm / inch	990/39
- with optional parking area	mm/inch	1440/56.7
Crosswise	mm / inch	40/1.6
Sphere-cylinder travel	mm / inch	14/0.5

Spindle

Max. spindle inclination	degrees	5
Spindle travel standard	mm / inch	240/9.4
- with long spindle option	mm/inch	290/11.4
Spindle motor power	KW / HP	2.2 / 3
Spindle rotation speed	RPM	40 to 840

Connections

Power supply	4kVA-230V-AC-1Ph-50/60 Hz
Pneumatic supply	bar / psi 6/87
Max. air flow	l/mn -CFM 400/15
Noise level at 300 RPM	DbA 72
Noise level at 800 RPM	DbA 82
Net weight approx. with parking area	kg / lbs 1500/3439 1650/3637

BASIC EQUIPMENT

Clamping system kit 020641

011915	Universal quick clamp x 2
010416	Short clamping bar x 2
010426	Long clamping bar x 2
010432	End clamping plate x 2
011425	Clamping block x 2
013958	Tilting fixture
014039	U parallel x 2
010434	2 Parallels 30x50x242 mm (1.18x1.97x9.53in)
017577	2 High parallels 20x38x300mm (0.787x1.5x11.8in)
009796	Set of 6 long pins
017576	Set of 6 short pins

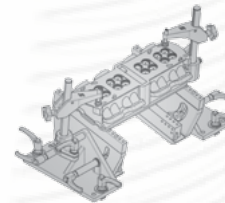

Optional accessories

034048
Toolrack



033828
Carbide bit sharpener



405580
Setting device SERDI 4200



024298
Bubble level



MACHINES SERDI S.R.

23, avenue des vieux moulins
B.P. 380
74012 Annecy Cedex
France

☎ 00 33 4 50 65 63 00

Fax: 00 33 4 50 52 99 92

www.serdi.com

Email: export@serdi.com

SERDI CORP.

1526 Litton Drive
Stone mountain
Georgia 30083
USA

☎ (770) 493 82 20

Fax: (770) 493 83 23

Your distributor:

Our machines are
designed and made in
France

Our tooling is made in
France and in the USA

