

4

3

2

1

B

B

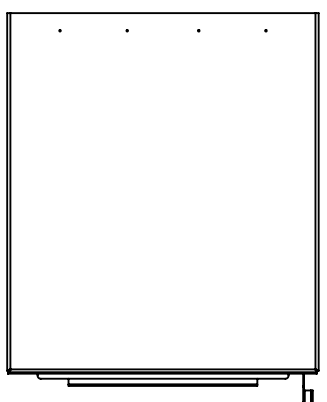
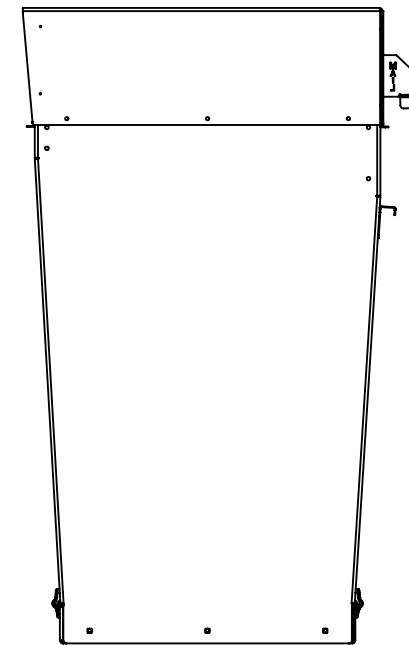

24.34

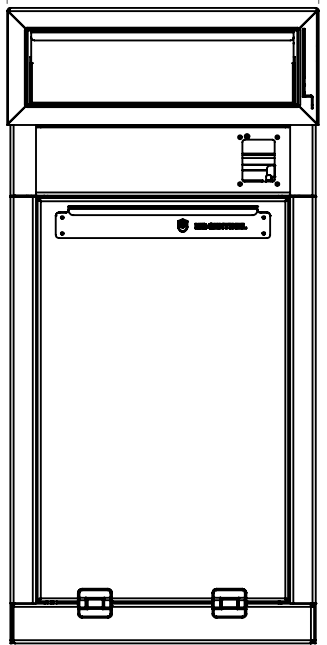

23.86

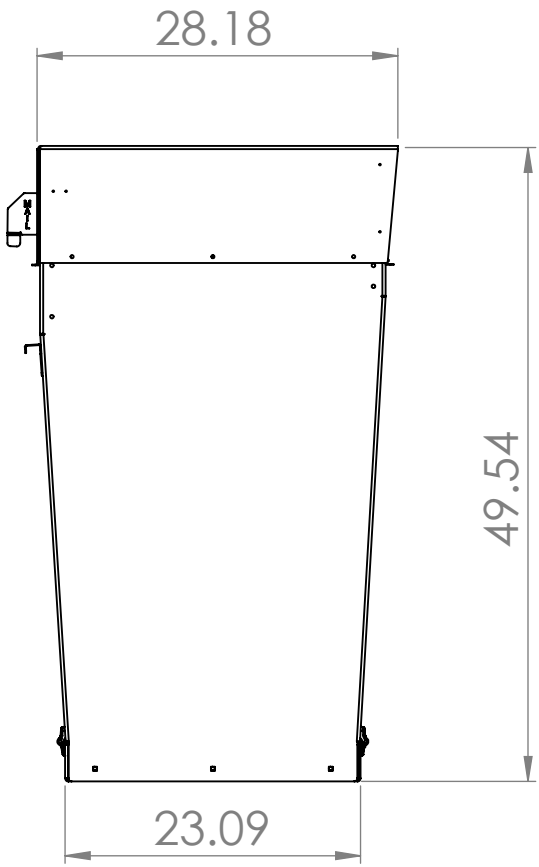

28.18

49.54

23.09

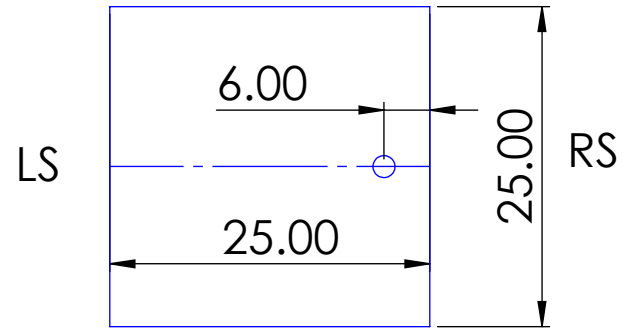
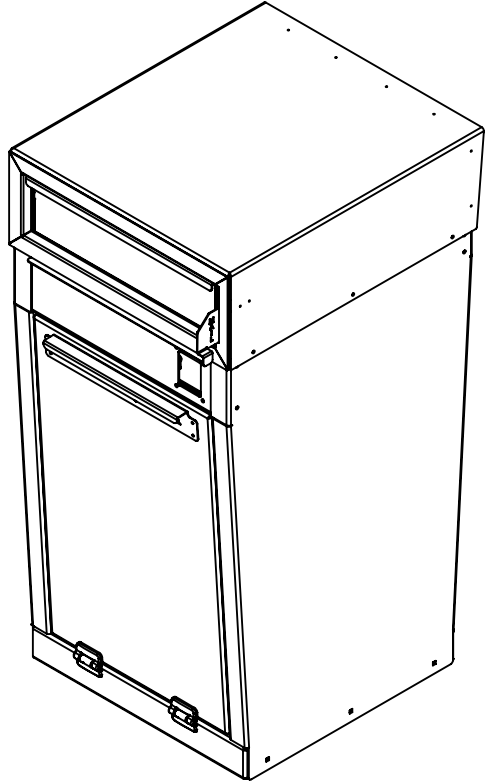

FRONT

*** CONCRETE PAD SHOULD BE 2" LARGER ON EACH SIDE THAN UNIT. PAD SHOULD BE 2" ABOVE GRADE. CONDUIT SHOULD BE PLACED IN PAD NEAR RIGHT SIDE OF UNIT. ****

A

A

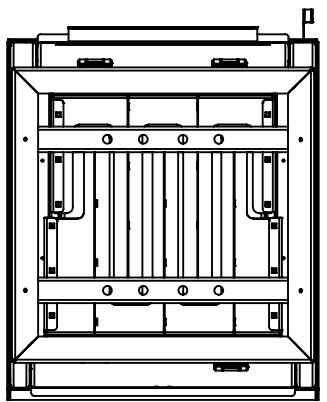

PROPRIETARY AND CONFIDENTIAL
 THE INFORMATION CONTAINED IN THIS DRAWING IS THE SOLE PROPERTY OF <INSERT COMPANY NAME HERE>. ANY REPRODUCTION IN PART OR AS A WHOLE WITHOUT THE WRITTEN PERMISSION OF <INSERT COMPANY NAME HERE> IS PROHIBITED.

		UNLESS OTHERWISE SPECIFIED:	NAME	DATE	MB SENTINEL		
		DIMENSIONS ARE IN INCHES	DRAWN				TITLE:
		TOLERANCES:	CHECKED		BOX SENTINEL LETTER TS		
		FRACTIONAL ±	ENG APPR.				
		ANGULAR: MACH ± BEND ±	MFG APPR.		SIZE	DWG. NO.	REV
		TWO PLACE DECIMAL ±	Q.A.		B	MBS-24-ARCH	NA
		THREE PLACE DECIMAL ±	COMMENTS:		SCALE: 1:15	WEIGHT:	SHEET 1 OF 1
NEXT ASSY	USED ON	MATERIAL					
		ASSY					
		FINISH					
		POWDERCOAT					
APPLICATION		DO NOT SCALE DRAWING					

4

3

2

1