

*Healthy Choice*<sup>®</sup>  
AF350

# 3.5L Air Fryer

with a beautiful gold trim



Model: AF350 | Batch: PR4491

**CAUTION:**

**TO AVOID DAMAGE TO YOUR BENCH TOP AND SPLASH BACK, DO NOT PLACE AIRFRYER DIRECTLY ON BENCH TOP.**

**Use air fryer on heat proof material and on a dry, level and even surface. Leave a minimum distance of 20cm from walls and other heat sensitive materials.**

**This appliance is intended for household use only.**

**Please read and retain these instructions for future reference.**

The illustrations used in the manual are to illustrate the operation method and structure of the product. Where there is a small difference between the physical item and the illustrations, please take the physical as the standard.

**CAUTION:**

TO AVOID DAMAGE TO YOUR BENCH TOP AND SPLASH BACK, DO NOT PLACE AIR FRYER DIRECTLY ON BENCH TOP.

Please use air fryer on heat proof material and on a dry, level and even surface. Leave a minimum distance of 20cm from walls and other heat sensitive materials.

Do not place the appliance against a wall or against a wall or against other appliances.

Hot air up to 160 Degrees expels through the rear vent of the appliance.

Leave at least 20cm clearance around the entire appliance, including directly above it.

Additional care should be taken when placing appliances on bench top surfaces or near splash backs where such materials (Acrylics, timber, stone etc.) do not have the high heat resistant properties.

Place the appliance on top of a heat resistant material between bench and appliance and further away from wall surfaces/ splash backs.

**IMPORTANT SAFEGUARDS:**

**When using electrical appliances, basic safety precautions should always be followed, including the following.**

1. Read instructions carefully before use.
2. Remove and safely disregard any packaging material and labels before using this product for the first time. Ensure children and babies do not play with plastic bags or any packaging materials.
3. Do not touch hot surfaces.
4. Before use, check that your local voltage corresponds with the specifications shown on the appliance nameplate located under the appliance.
5. Do not turn on power until this appliance and parts are in place as required. Make sure the door is closed before plugging and switching on the power.
6. To protect against electric shock, do not immerse the cord, plug, or this appliance in water or other liquid.
7. Close supervision is necessary when any appliance is used near children.

8. Unplug from outlet when not in use and before cleaning. Allow the appliance to cool down (if relevant) before putting on or taking off parts, and before cleaning the air fryer.

9. Do not operate the any appliance with a damaged cord or plug or after the appliance or is dropped or damaged in any manner, take it to the store where the appliance was purchased or call customer service for further assistance.

10. Do not use the appliance for other than intended use. It is for household use only. It is not to be used outdoors or for commercial purposes.

11. This appliance is intended to be used in household and similar applications such as:

-staff kitchen areas in shops, offices and other working environments;

-farm houses;

-by clients in hotels, motels and other residential type environments;

-bed and breakfast type environments

12. The air fryer should be operated on a separate electrical power point from other operating appliances. If the power point is overloaded with other appliances, this air fryer may not work properly.

13. Extreme caution must be used when moving an air fryer containing hot food.

14. Do not place on or near a hot gas or electric burner, or in a heated oven. Also keep away from the flammable material such as curtains, draperies when it is working.

14. Leave enough open space from other subject when in use.

15. Do not let cord hang over the edge of table or counter or touch hot surface.

16. Do not leave the cord hanging.

17. Do not unplug the air fryer by pulling on the cord.

18. Do not cover the air fryer while in use.

19. This appliance is not designed to be used by people (including children) with a physical, sensory or mental impairment, or people without knowledge or experience, unless they are supervised or given prior instructions concerning the use of the appliance by someone responsible for their safety. Children must be supervised to ensure that they do not play with the air fryer.

#### **SHORT CORD INSTRUCTIONS:**

Do not use with an extension cord. A short power supply cord is provided to reduce the risks resulting from being entangled in or tripping over a long cord.

## **PREPARATION FOR USE:**

Before using the air fryer for the first time:

**Warning: when using for the first time, the air fryer may emit slight odour which is not harmful and will disappear after a few minutes. This is because a protective oil was applied to protect parts from possible friction in transport.**

Carefully unpack the air fryer and remove all the packing materials. Select a flat, heat-resistant Non-flammable surface to place the air fryer.

Use sponge and soapy water to remove any dust on the surface that may happen during packing and transport. Allow it to dry before use.

Remove any stickers or labels from the appliance – other than the rating label.

Thoroughly clean the frying basket and grill tray with hot water and some liquid dish washing soap, using a non-abrasive sponge.

Note: You can also clean these parts in the dishwasher.

## **AUTOMATIC SWITCH OFF:**

This appliance is equipped with a timer. When the timer has counted down to 0, the appliance alerts a bell sound and switches off automatically. To switch off the appliance manually, turn the timer knob anticlockwise to 0. The fan will continue running to cool down the appliance for up to 30 seconds.

**THE UNIT:**

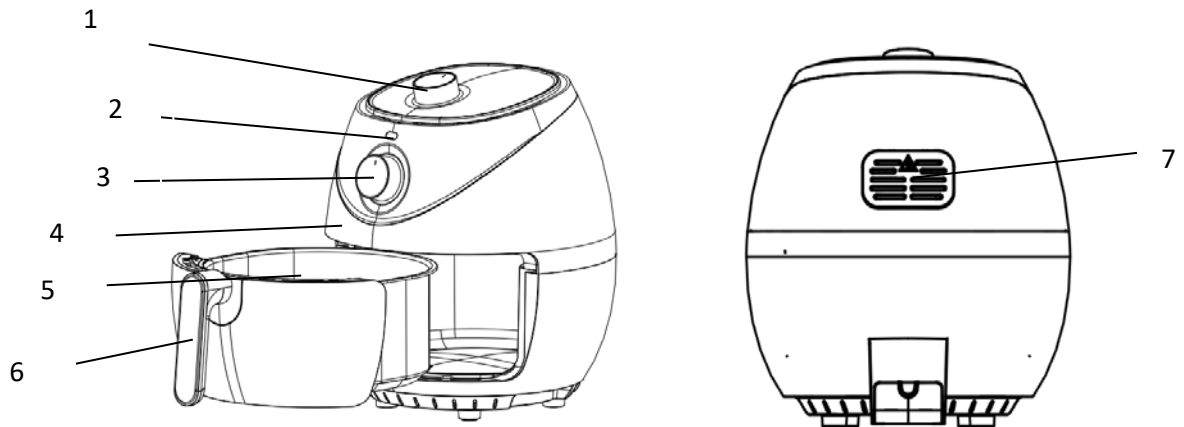

- 1. Temperature control dial
- 2. Power indicator
- 3. Timer dial
- 4. Main housing
- 5. Frying basket (goes into the air fryer)
- 6. Basket handle
- 7. Air outlet

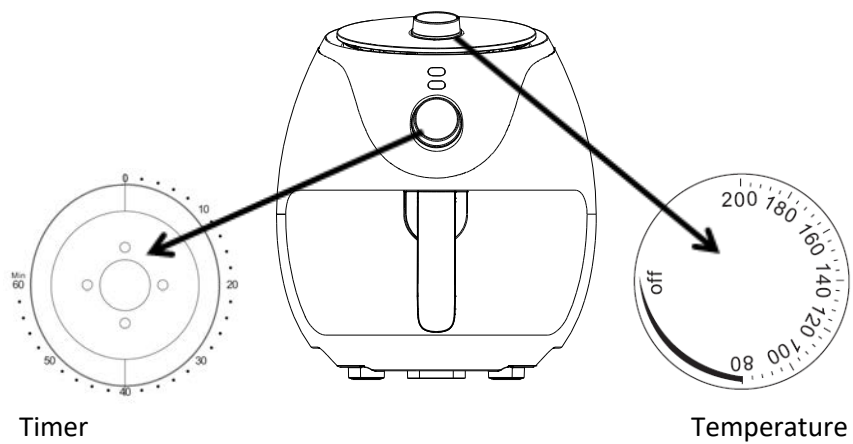

The grill tray needs to be inside the frying basket when the air fryer is being used.

The silicone rubbers stay on the grill tray, they are food safe and will not melt.

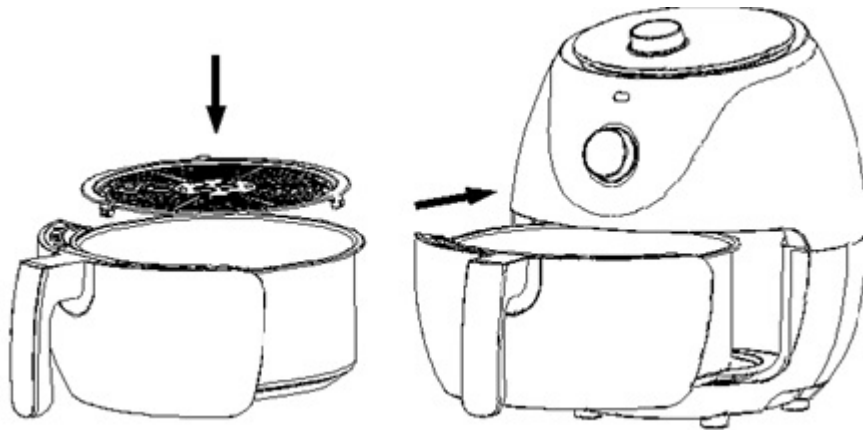

### PREPARING FOR USE:

1. Place the appliance on a stable, horizontal and level surface that is also heat resistant.
2. Place the grill tray in the frying basket.
  - Do not fill the frying basket with oil or any other liquid.
  - Do not put anything on top of the appliance. This disrupts the airflow.

### USING THE AIR FRYER:

This is an air fryer that works on hot air. Do not fill the fry pot with oil or frying fat.

1. Plug in the appliance to the mains power supply.
2. Carefully pull the frying basket out of the air fryer. Ensure the grill tray is inside the frying basket. Put the food into the frying basket.

- Note: Never fill the frying basket beyond the amount indicated in the table shown in the section. COOKING TIMES AND TEMPERATURES, as this could affect the quality of the food. Never cook food without the grill tray in place.

3. Slide the frying basket back into the air fryer.
4. Turn the temperature control knob to the required temperature. To switch on the appliance, turn the timer knob to the required preparation time. Add 3 minutes to the preparation time when the appliance is cold.

- Note: You can also let the appliance preheat without any food inside.

In that case, turn the timer knob to a little more than 3 minutes and set your chosen cooking temperature.

Wait until the timer light goes out (after 3 minutes).

Then fill the frying basket with food and turn the timer knob to the required preparation time.

5. The timer indicator (red) will remain on while the air fryer is operating. The timer starts counting down the set preparation time.

6. Excess oil from the food is collected at the bottom of the frying basket.

7. Some foods require shaking halfway through the preparation time. To shake the food, pull the frying basket out of the appliance by the handle and shake it. Then slide the frying basket back into the air fryer.

- Tip: If you set the timer to half the preparation time, you hear the timer bell when you have to shake the ingredients. However, this means that you have to set the timer again for the remaining

preparation time after shaking.

8. When you hear the timer bell, the set preparation time has elapsed. Pull the frying basket out of the appliance and place it on a heat-resistant surface.

- Note: You can also switch off the appliance manually. To do this, turn the timer knob anticlockwise to 0.

9. Check if the food is thoroughly cooked. If the food isn't ready yet, simply slide the frying basket back into the appliance and set the timer to a few extra minutes.

10. After hot air frying, the frying basket, grill tray and the food are all hot. Depending on the type of recipe in the air fryer, steam may escape from the frying basket. Use tongs (not included) to remove the cooked food out of the frying basket.

The air fryer is ready to be used again.

### COOKING TIMES AND TEMPERATURES:

- This table helps you to select the basic settings for the food you want to prepare.  
Note: Keep in mind that these settings are only for reference. As ingredients differ in origin, size, shape as well as brand, we cannot guarantee the best setting for your ingredients.
- Due to the Rapid Air Technology instantly reheating the air inside the appliance, pulling the frying basket out during hot air frying will disturb the process.
- Shaking smaller ingredients halfway through the preparation time prevents uneven cooking.
- You can coat fresh potatoes with a little oil for a crispy result.
- Do not prepare extremely greasy foods such as sausages in the air fryer.
- Snacks like frozen spring rolls that can be prepared in an oven can also be prepared in the air fryer.
- You can also use the air fryer to reheat food by setting the temperature to 150°C and the timer to around 10 minutes.

RECIPE	WEIGHT	TIME	TEMP	SHAKE	EXTRA INFO
<i>POTATOES &amp; CHIPS</i>					
Thin frozen chips	300 – 700g	15 – 20 min	200°C	Halfway through	
Thick frozen chips	300 – 700g	15 – 20 min	200°C	Halfway through	
Homemade fries	300 – 800g	23 – min	180°C	Halfway through	Add ½ tbsp oil
Homemade potato cubes	500 – 600g	20 – 25 min	200°C	Halfway through	Add ½ tbsp oil
Rosti	250g	18 – 22 min	180°C		
Potato gratin	500g	20 – 20 min	180°C		
<i>MEAT &amp; POULTRY</i>					
Steak	100 – 500g	12 – 22 min	180°C		Turn over if needed

Pork chops	100 – 500g	10 – 20 min	180°C		Turn over if needed
Hamburger	100 – 500g	10 – 15 min	180°C		Turn over if needed
Sausage rolls	100 – 500g	13 – 15 min	200°C		Turn over if needed
Drumsticks	100 – 500g	18 – 25 min	180°C	Halfway through	
Chicken breast	100 – 500g	15 – 20 min	180°C		Turn over if needed
<b>SNACKS</b>					
Spring rolls	100 – 400g	10 – 15 min	200°C	Halfway through	Use oven ready
Frozen fish fingers	100 – 500g	10 – 15 min	200°C	Halfway through	Use oven ready
Mozzarella sticks	100 – 400g	12 min	200°C		Use oven ready
Stuffed vegetables	100 – 400g	12 min	160°C		Use oven ready

#### **TIPS:**

- A smaller amount of food requires a slightly shorter preparation time; a larger amount of food needs a slightly longer preparation time.
- It is recommended not to fill the frying basket of the air fryer beyond  $\frac{3}{4}$  of its capacity. The maximum amount of ingredients that can be prepared depends on the kind of food you want to prepare.
- Shaking smaller ingredients halfway through the preparation time optimizes the end result and can help prevent unevenly fried ingredients.
- Use pre-made dough to prepare filled snacks quickly and easily. Pre-made dough also requires a shorter preparation time than home-made dough.
- Place a baking tin (not included) or oven dish (not included) in the air fryer pot if you want to bake a cake or quiche or if you want to fry fragile ingredients or filled ingredients
- You can also use the air fryer to reheat ingredients. To reheat ingredients, set the temperature to 150°C for up to 10 minutes.
- If you use oven-ready snacks, do not add oil because they are usually pre-fried and become golden brown and crispy when prepared in the air fryer.
- If you use oven-ready snacks and they do not become crispy and stay pale, please check the following:
  - a. The amount of ingredients: Put smaller batches of ingredients in the fry pot. Cover the bottom of the fry pot with just one layer. Smaller batches are fried more evenly.
  - b. The preparation time: If you have not preheated the appliance before you put in the snacks, make sure you add 3 minutes extra to the preparation time when you set the timer.
  - c. Most snacks need the preparation time indicated for the oven to become fully cooked.
  - d. If your croquettes or snacks burst when you prepare them in the air fryer, choose a shorter preparation time.

#### **CLEANING:**



Clean the appliance after every use. The grill tray, frying basket and the inside of the appliance have a non-stick coating. Do not use metal kitchen utensils or abrasive cleaning materials to clean these parts, as this may damage the non-stick coating.

1. Unplug the appliance from the mains power supply and allow it to cool down.
2. Wipe the outside of the appliance with a moist cloth.
3. Clean the frying basket and grill tray with hot water, some dish washing liquid soap and a non-abrasive sponge. You can use a degreasing liquid to remove stubborn spots. If food residue is stuck to the frying basket or the grill tray, fill the frying basket with hot water and some dish washing liquid soap. Put the grill tray in the frying basket and let the grill tray and the frying basket soak for approximately 10 minutes.
4. Lightly brush the heating element with a cleaning brush to remove any crumbs.

**STORAGE:**

1. Unplug the appliance from the mains power supply and allow it to cool down.
2. Make sure all parts are clean and dry.
3. Store in an upright position with the frying basket closed.

**TROUBLESHOOTING:**

Problem	Possible cause	Solution
The air fryer does not work.	The appliance is not plugged into the mains power supply.	Plug the appliance into the mains power supply and check to ensure the power supply is properly working.
	You have not set the timer.	Turn the timer knob to the required Preparation time to switch on the appliance.
The food is not thoroughly cooked.	There is too much food in the frying basket.	Put smaller batches of food in the frying basket. Smaller batches are fried more evenly.
	The set temperature is too low.	Turn the temperature control knob to the required temperature setting.
	The preparation time is too short.	Turn the timer knob to the required preparation time.
The food is unevenly cooked.	Certain types of food need to be shaken halfway through the preparation time.	Check to see if your recipe requires a shake halfway through the preparation time.
The frying basket will not slide into the appliance properly.	There is too much food in the frying basket.	Never fill the frying basket beyond the amount indicated in the table shown in the section COOKING TIMES AND TEMPERATURES.

White smoke comes out of the appliance.	You are preparing greasy ingredients.	While cooking greasy food, oil leaks to the bottom of the frying basket producing white smoke; this will not harm the appliance and the food is safe.
---	---------------------------------------	---

**SPECIFICATIONS:**

Voltage	220-240V
Power	1500W
Timer range:	0 – 60 minutes
Temperature range:	80 – 200 degrees
Capacity of fry pot	3.5 Litres

**LENOXX**

[www.lenoxx.com.au](http://www.lenoxx.com.au)

 1300 666 848

 LenoxxElectronics

 LenoxxElectronics

 @LenoxxAustralia