

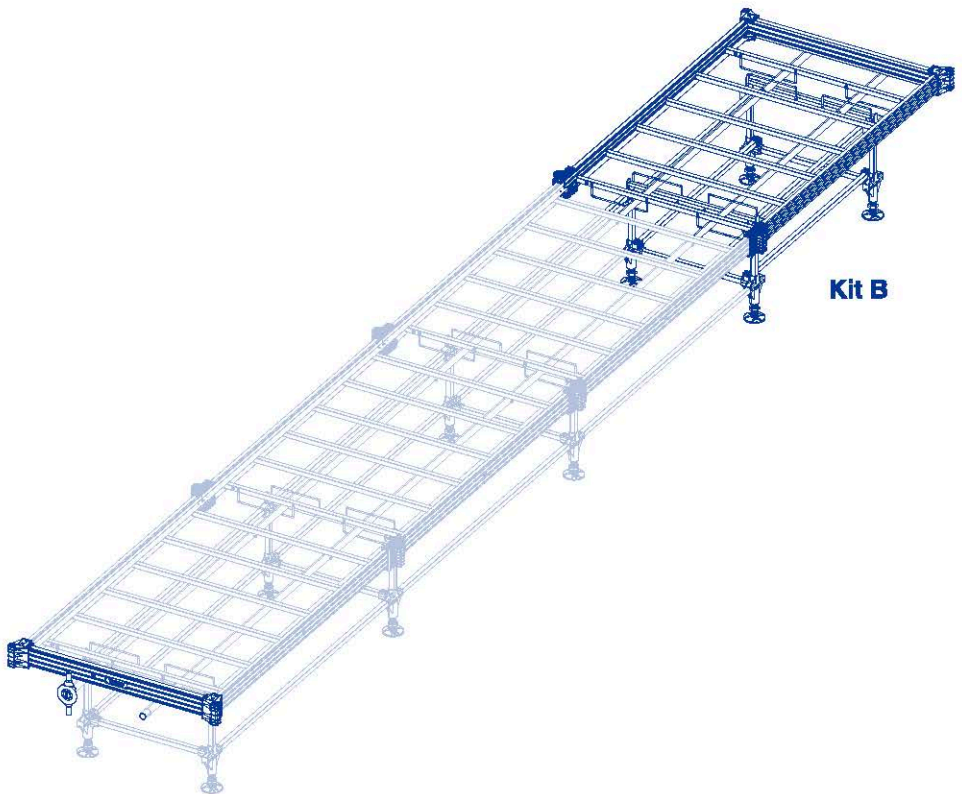

Rolling Bench

Kit B

Assembly instructions



Kit - Start



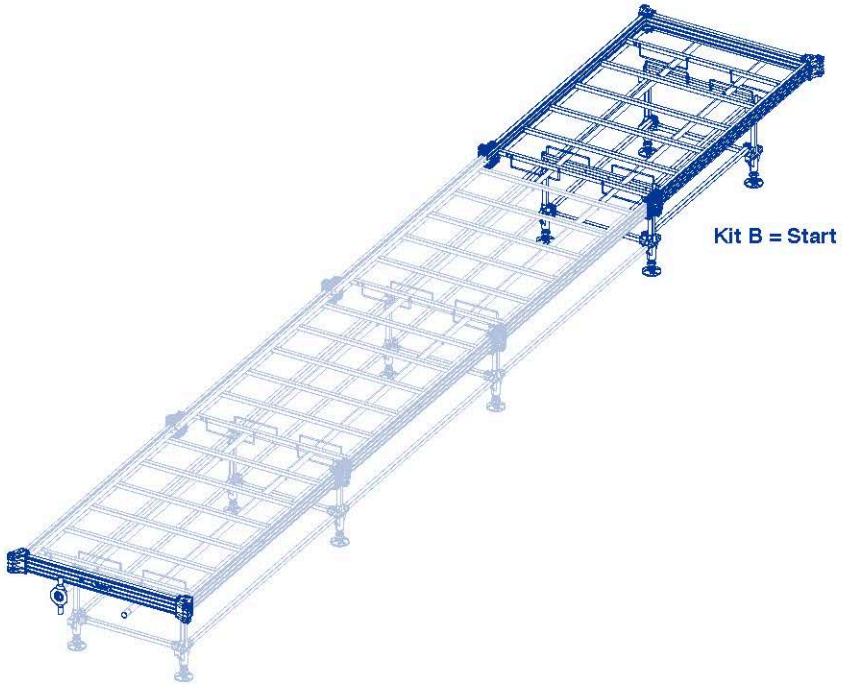











It's important to always start with Kit B when you start building a new table.



Kit - Warning



Take note that before you screw the table in the floor you have to:

- Level the entire table
- Adjust the water dripping slope
- Adjust the length of the Kit B
- Make sure that the top of the table is in straight line



Part	Qty	Description	Part	Qty	Description
# 1	X13	Mounting Nut (M6)	# A1	X2	Right Angle Plastic Connector 
# 2	X9	Mounting Bolt (M6*55L)	# B1	X2	Right Angle Plastic Connector 
# 3	X68	Mounting Bolt (M6*18L)	# B2	X2	Straight Plastic Connector 
# 4	X65	Mounting Washer	# B4	X4	Leg 
# 5	X2	Square Bar (Short)	# B-R	X1	Right Aluminum Side 
# 6	X2	V-Shape Bar	# B-L	X1	Left Aluminum Side 
# 7	X8	Mounting Bolt (M6*8L)	# A-A	X1	Aluminum Side 
# 8	X4	Square Bar (Long)	# B-B	X1	End Aluminum Side 
# 9	X8	Small Plastic Piece	# 20	X16	Plastic Cap (41*41) 
# 10	X2	Rolling Bar Kit B	# 21	X8	Square Plastic Cap (30*30) 
# 11	X2	Metal Trust With Side Holes	# 22	X2	Round Plastic Cap (D=42) 
# 12	X4	Metal Trust	# 23	X1	Round Plastic Cap (D=38) 
# 13	X8	Right Angle Metal Connector	Also includes assembly tools:		
# 18	X4	Straight Metal Connector	• Hex Wrench 4mm (x2) 		
# 19	X1	Turnable Handle	• Open-Ended Wrench 10mm (x2) 		
# C-1	X4	U-Shape Part (Long)			
# C-2	X4	U-Shape Part (Short)			

Kit B - Parts

Part Qty

- # 1 X6 
- # 2 X4 
- # 3 X6 

Part Qty

- # 4 X4 
- # 5 X1 
- # 6 X1 

Part Qty

- # B4 X2 
- # C-2 X2 

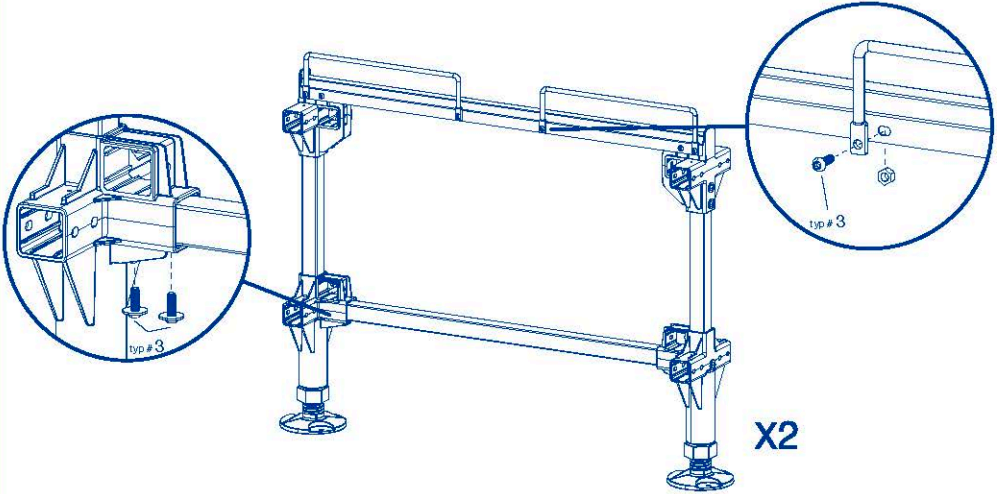
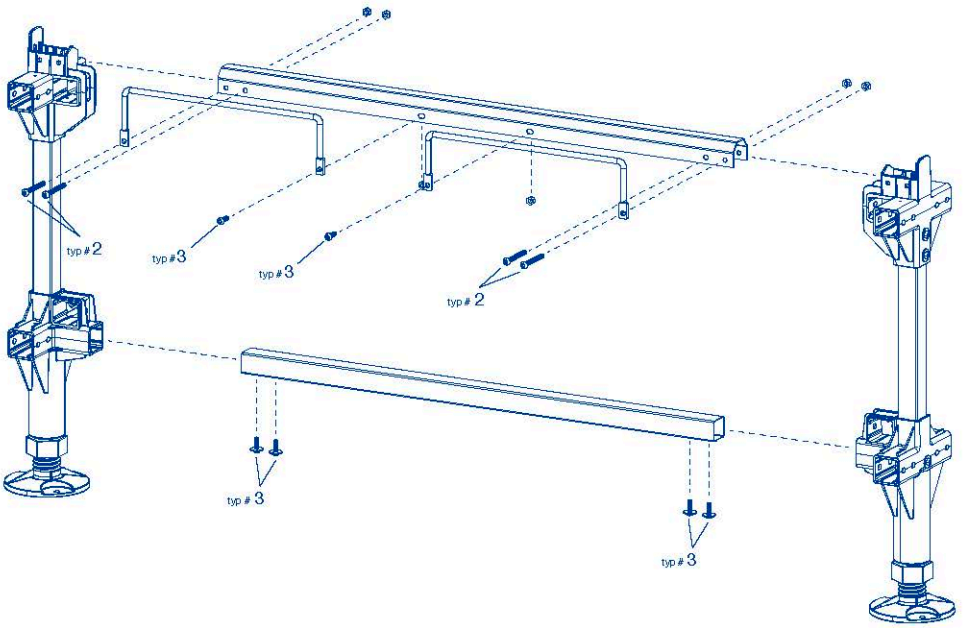

Kit B - Step 1

Part Qty

3 X4

4 X4



Part Qty

8 X4

9 X4



Part Qty

21 X16

X1



X4

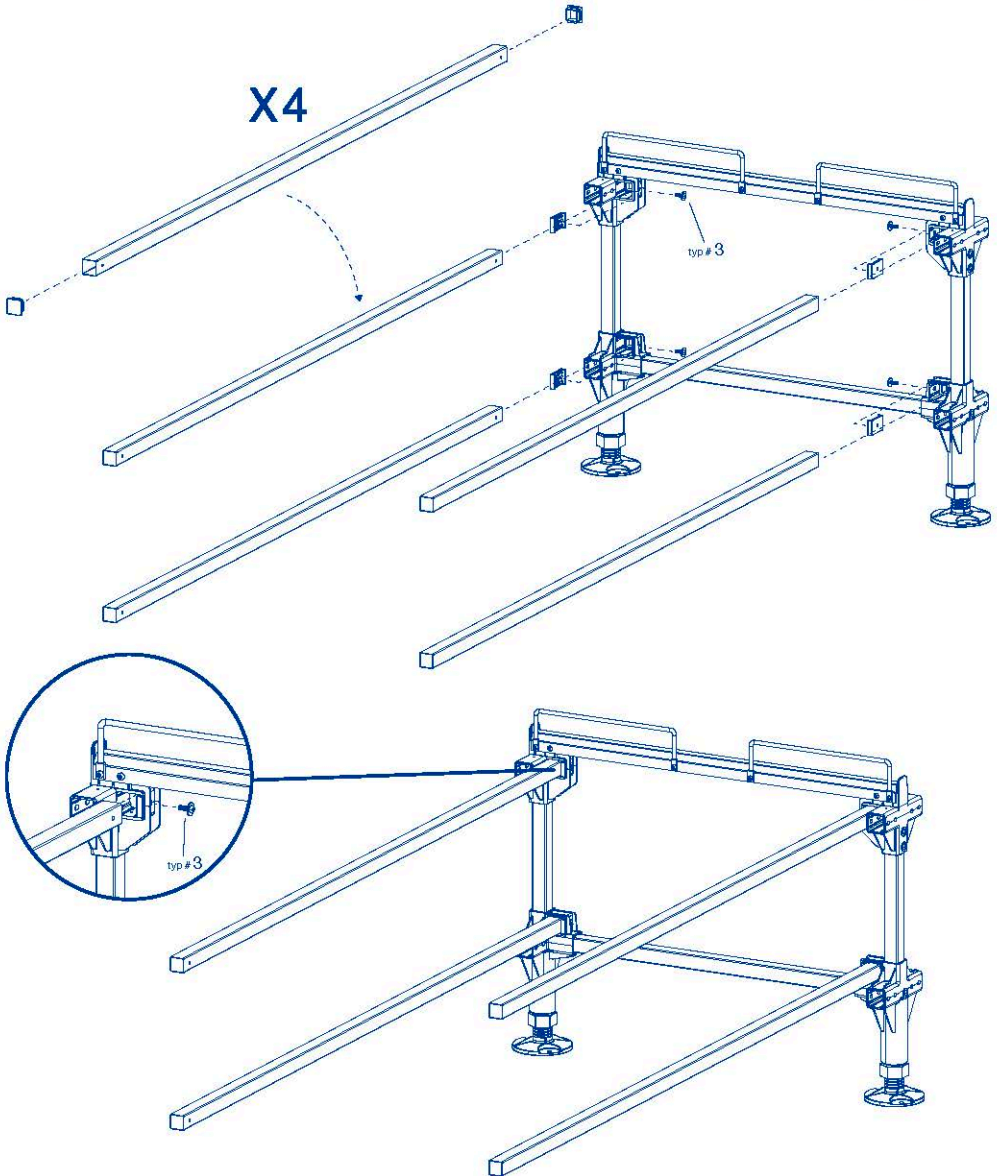

Kit B - Step 2

Part Qty

3 X4

4 X4



Part Qty

9 X4



Part Qty

X1

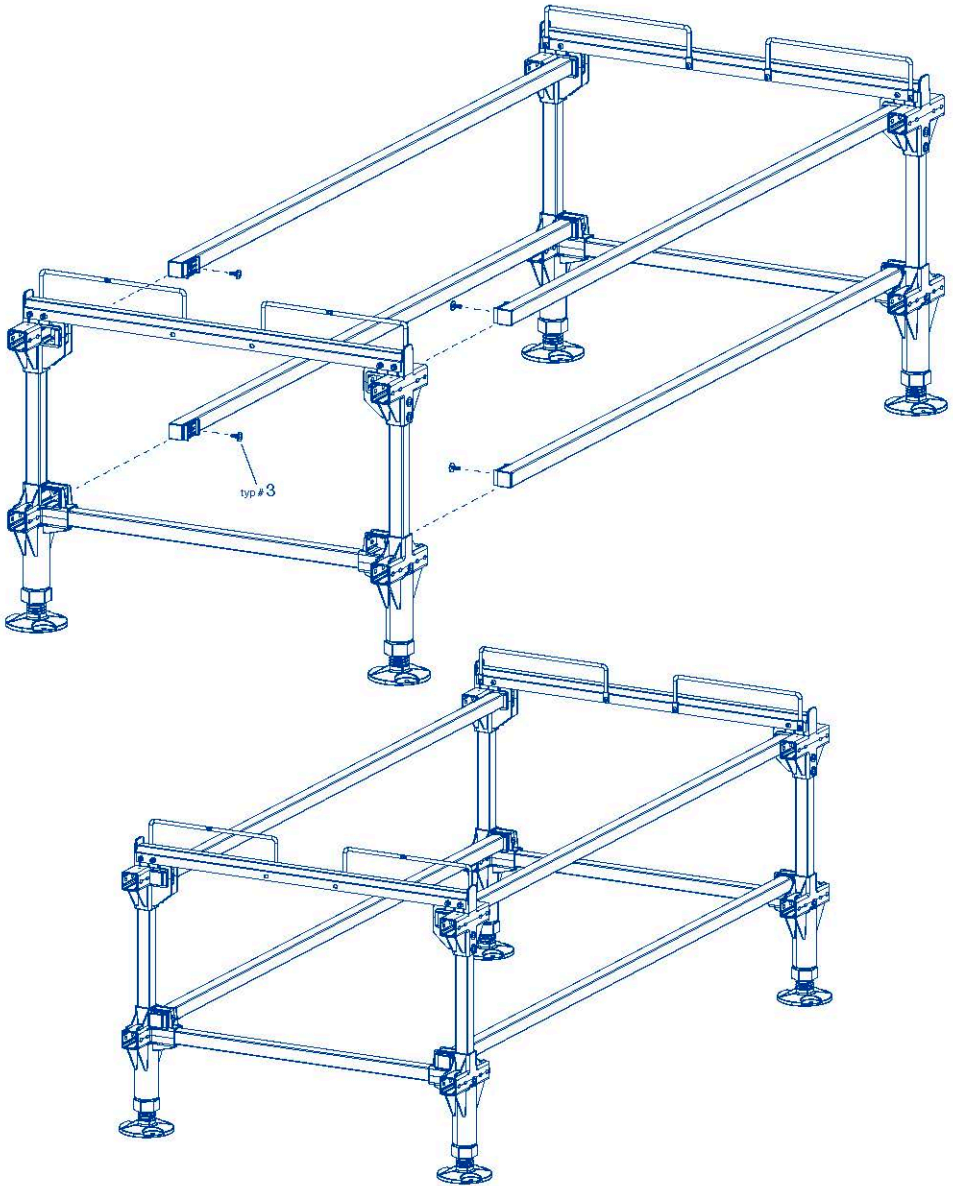

Kit B - Step 3

Part Qty

20 X12

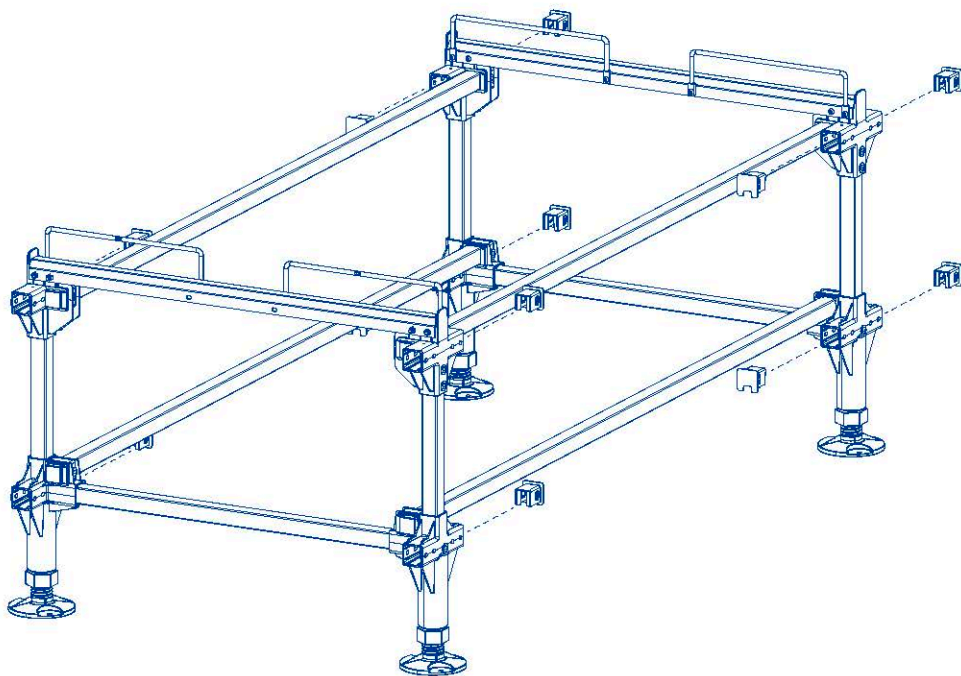

Kit B - Step 4

Part Qty

10 X2



Part Qty

22 X2

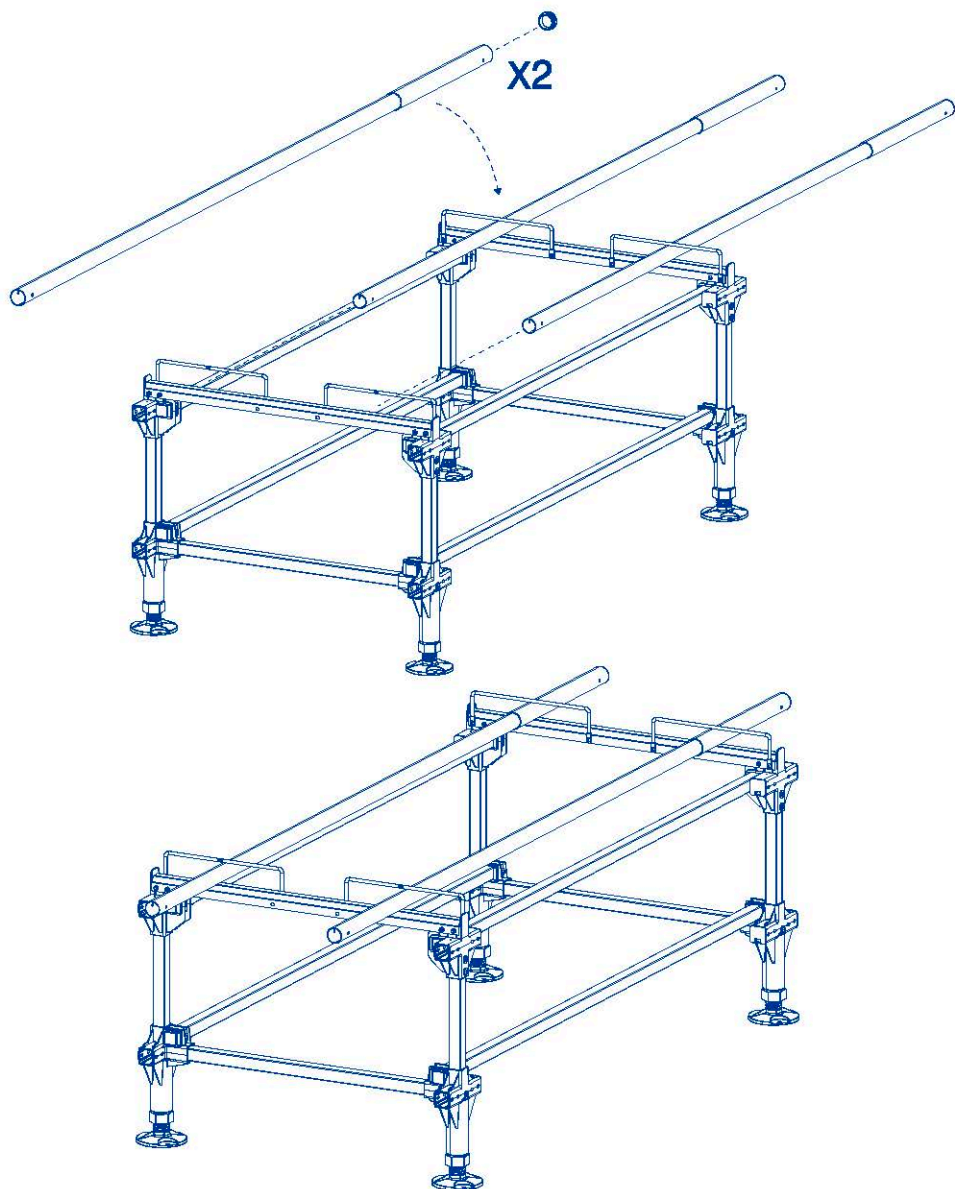

Kit B - Step 5

Part Qty

3 X12



4 X12



Part Qty

11 X2



12 X4



Part Qty

B-R X1



B-L X1

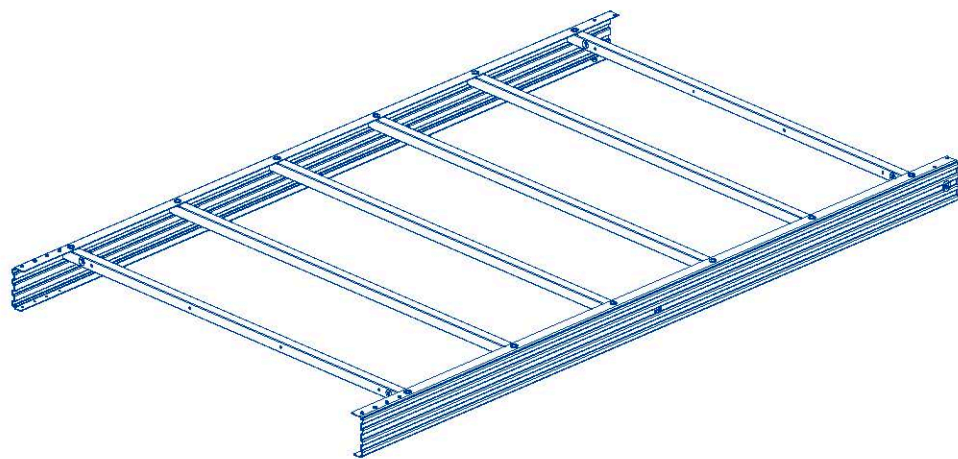
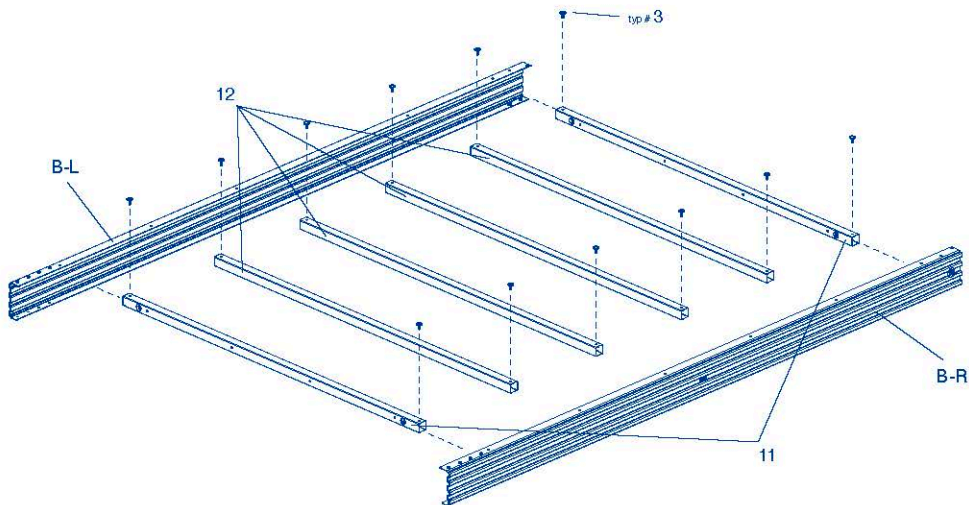

Kit B - Step 6

Part Qty

B1 X2



Part Qty

B-B X1

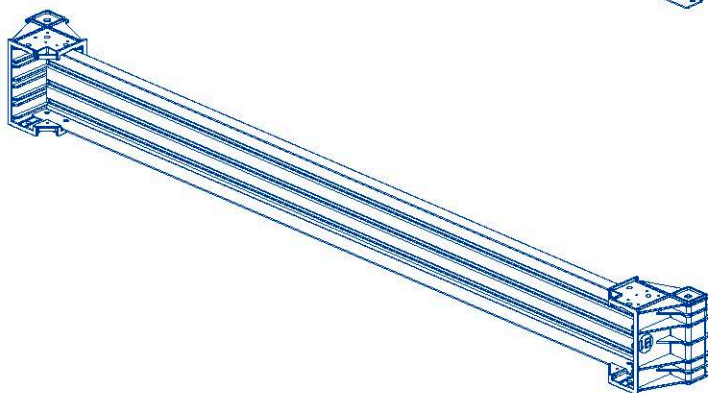
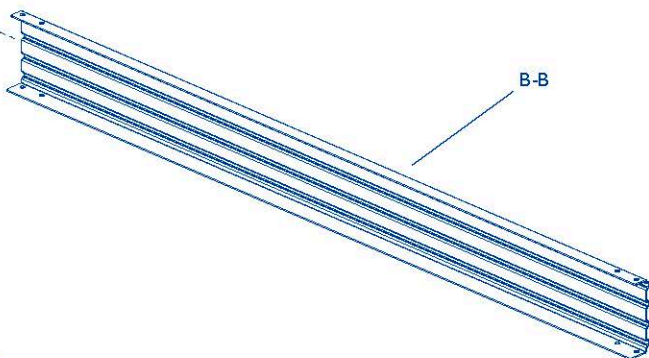

NOTE: Angle Plastic Connectors
A1 and End Aluminum Sides
A-A must be kept apart for Kit A.

Kit B - Step 7

Part Qty

3 X12

4 X12



Part Qty

13 X4



Part Qty

X1

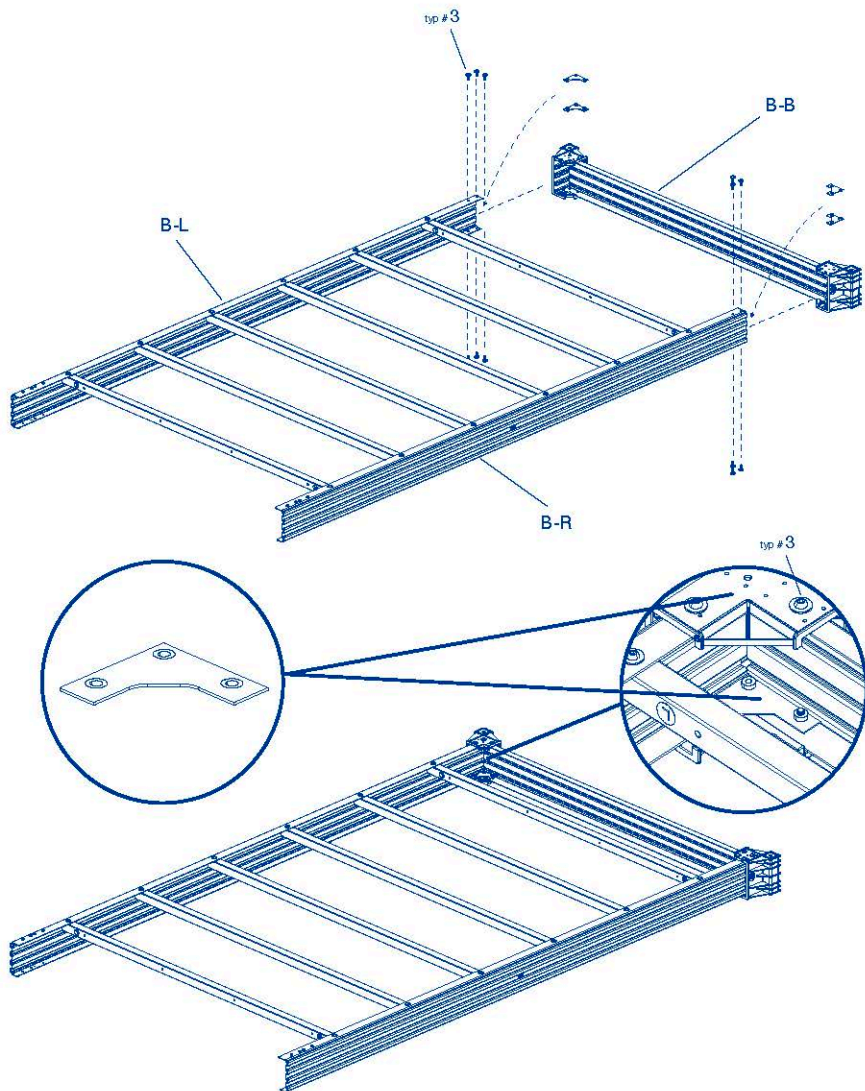

Kit B - Step 8

Part Qty

3 X8



Part Qty

4 X8



Part Qty

B2 X2

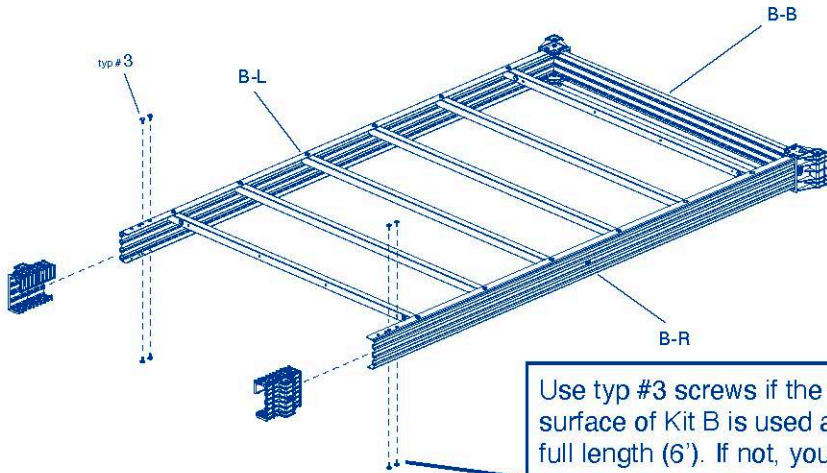

Use typ #3 screws if the table surface of Kit B is used at its full length (6'). If not, you need to use the typ #7 screws instead of the typ #3 screws.

7 X8

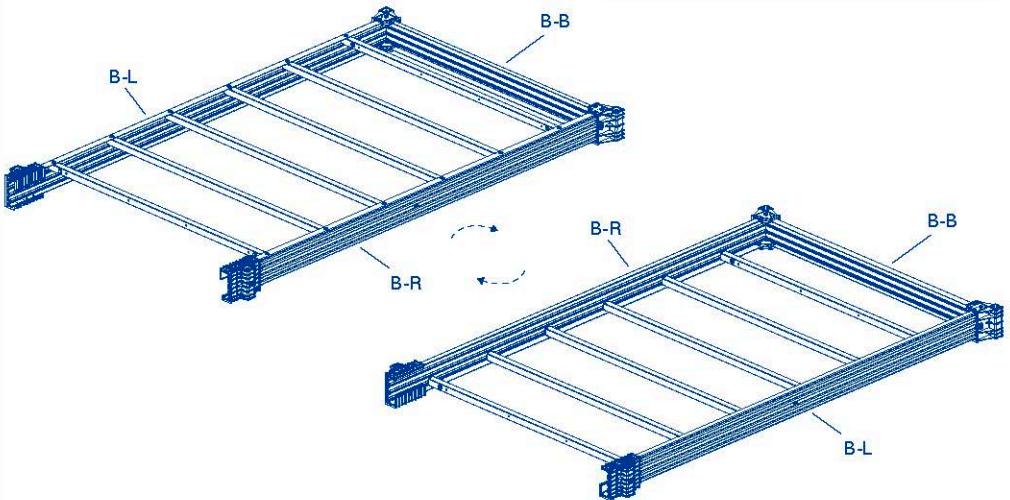

Kit B - Step 9

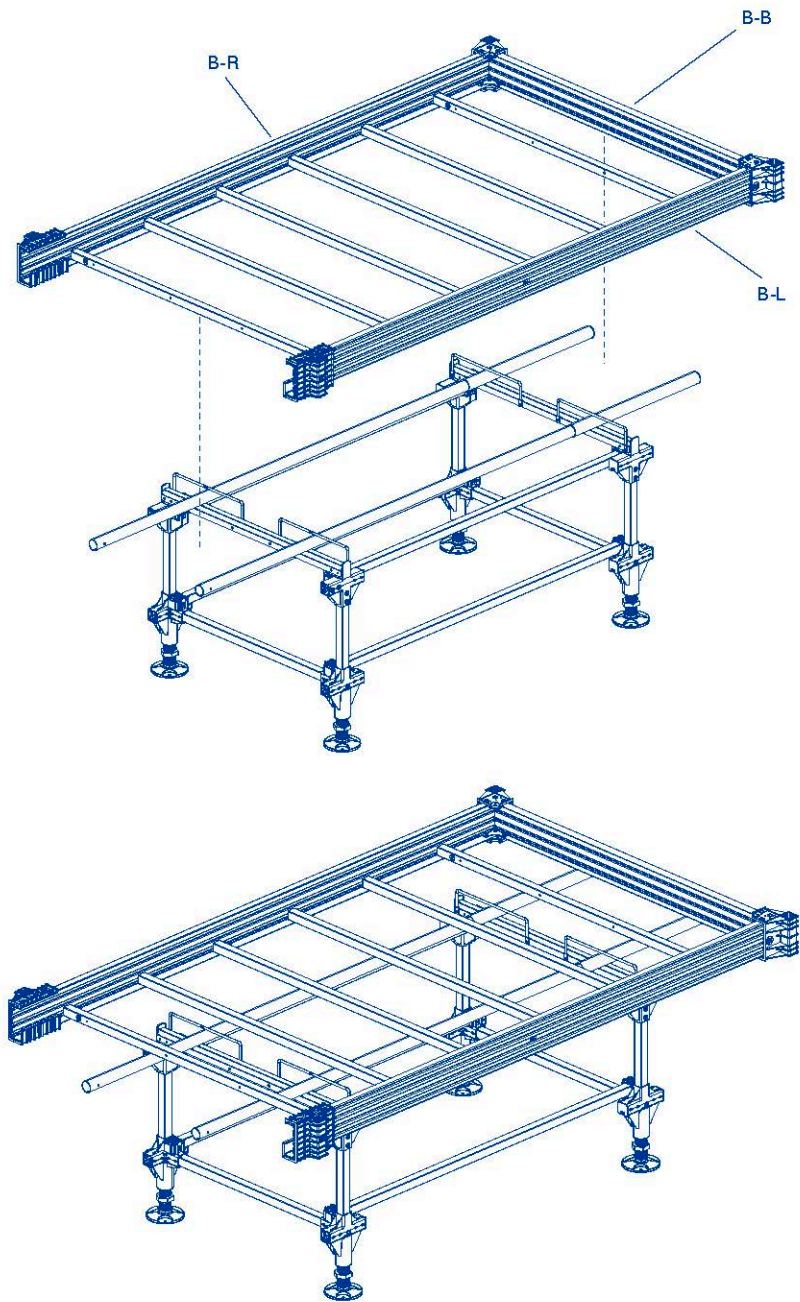

Kit B - Step 10

Part Qty

3 X8



Part Qty

4 X8



Part Qty

C-1 X4

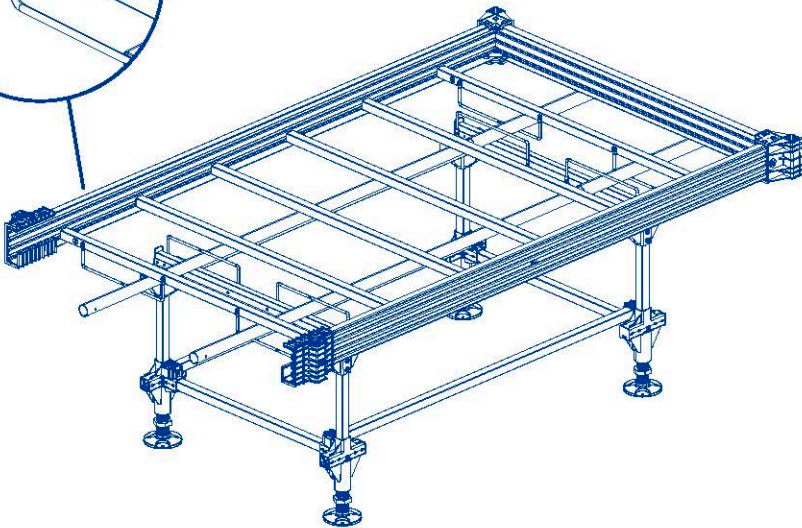
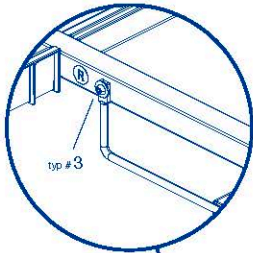
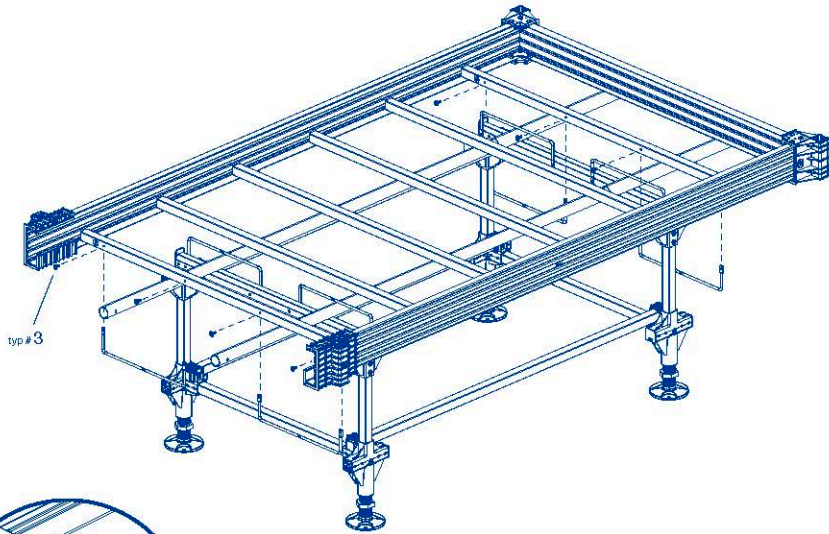

Kit B - Step 11

Remains Parts

The remaining parts need to be used to close the table when the length is determined. The steps of the assembling of those parts are illustrated in the Kit's A booklet.

Part	Qty	Description	Part	Qty	Description
# 1	X1	Mounting Nut (M6)	# 19	X1	Turnable Handle
# 2	X1	Mounting Bolt (M6*55L)	# A1	X2	Right Angle Plastic Connector
# 3	X12	Mounting Bolt (M6*18L)	# A-A	X1	Aluminum Side
# 4	X13	Mounting Washer	# 20	X4	Plastic Cap (41*41)
# 13	X4	Right Angle Metal Connector	# 23	X1	Round Plastic Cap (D=38)
# 18	X4	Straight Metal Connector			

Keep those parts for Kit A's booklet.

IMPORTANT NOTE

Plastic tray with drain
must always be
installed on Kit B.



Rolling Bench

Kit A

Assembly instructions

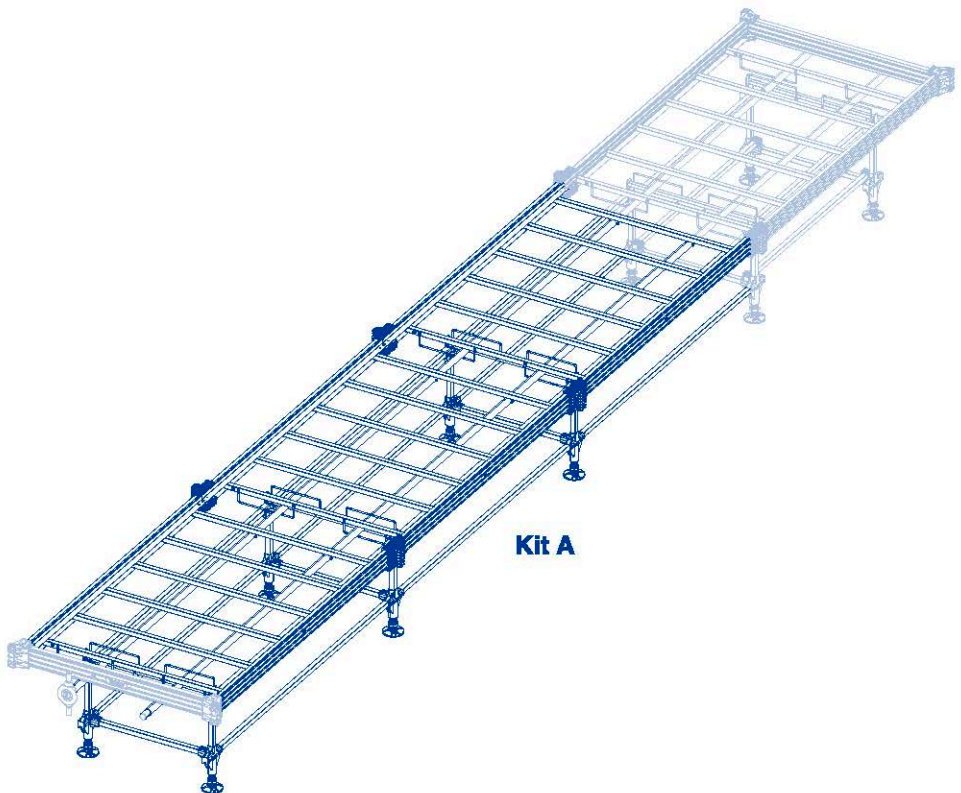

Kit - Start



















It's important to always start with Kit B when you start building a new table.



Kit - Warning

Take note that before you screw the table in the floor you have to :

- Level the entire table
- Adjust the water dripping slope
- Adjust the length of the Kit B
- Make sure that the top of the table is in straight line



Part	Qty	Description	Part	Qty	Description
# 1	X8	Mounting Nut (M6) 	# A1	X2	Right Angle Plastic Connector 
# 2	X6	Mounting Bolt (M6*55L) 	# A2	X2	Straight Plastic Connector 
# 3	X54	Mounting Bolt (M6*18L) 	# A4	X2	Leg 
# 4	X50	Mounting Washer 	# A-R	X1	Right Aluminum Side 
# 6	X1	V-Shape Part 	# A-L	X1	Left Aluminum Side 
# 11	X1	Metal Trust With Side Holes 	# C-1	X2	U-Shape Part (Long) 
# 12	X5	Metal Trust 	# C-2	X2	U-Shape Part (Short) 
# 14	X1	Square Bar (Short) 			
# 15	X4	Square Bar (Long) 			
# 16	X2	Rolling Bar of Kit A 			
# 17	X4	AA Straight Metal Connector 			

Also Includes assembly tools:



- Hex Wrench 4mm (x2) 
- Open-Ended Wrench 10mm (x2) 

Kit A - Parts

Part Qty

- # 1 X6 
- # 2 X4 
- # 3 X6 

Part Qty

- # 4 X4 
- # 6 X1 
- # 14 X1 

Part Qty

- # A4 X2 
- # C-2 X2 

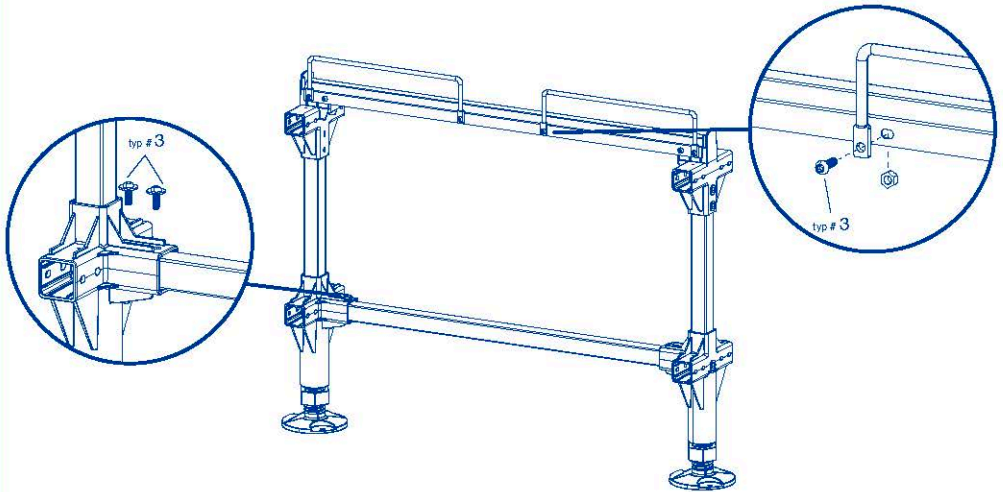
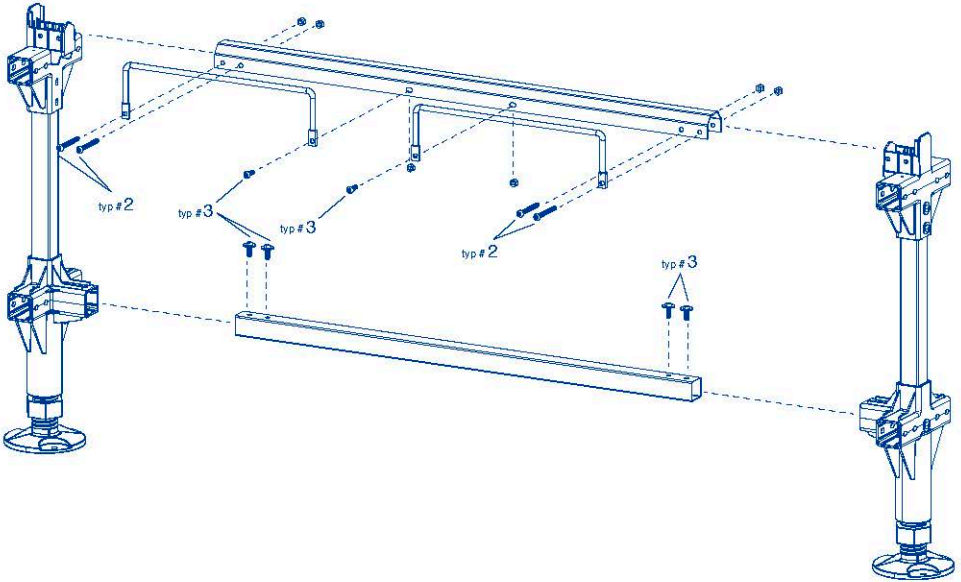

Kit A - Step 1

Part Qty

3 X8

4 X8



Part Qty

15 X4



Part Qty

X1

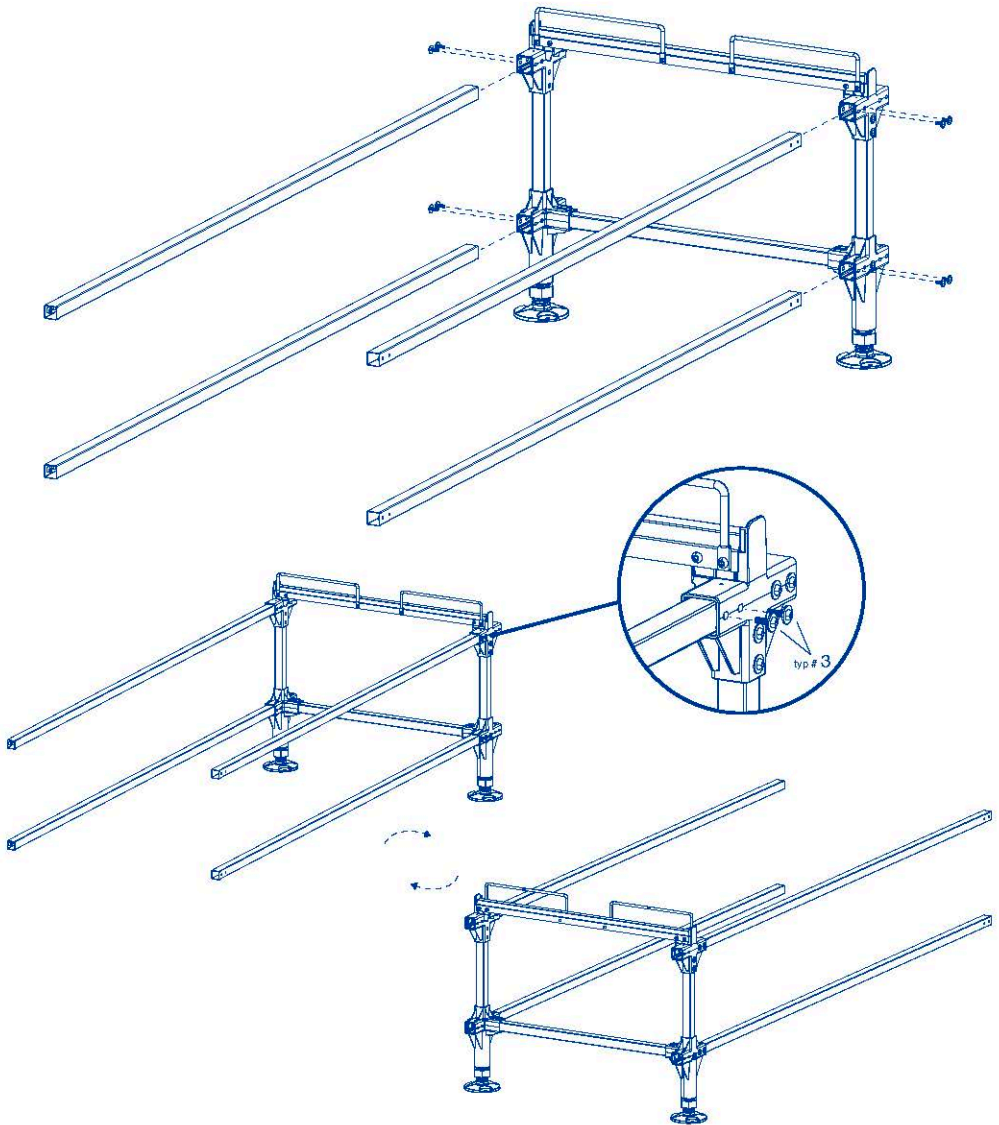

Kit A - Step 2

Part Qty

3 X8



Part Qty

4 X8



Part Qty

X1

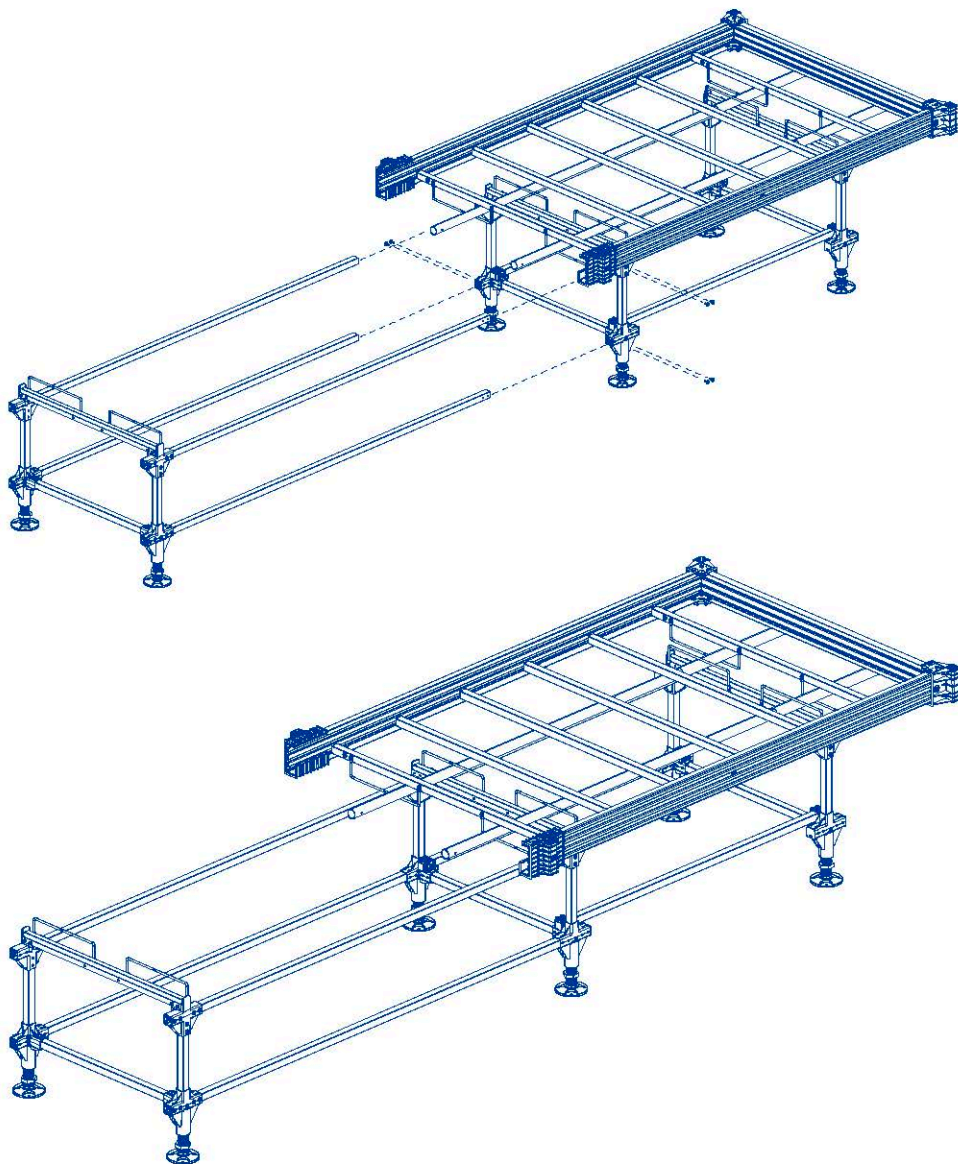

Kit A - Step 3

Part Qty

1 X2



2 X2



Part Qty

4 X2



Part Qty

16 X2

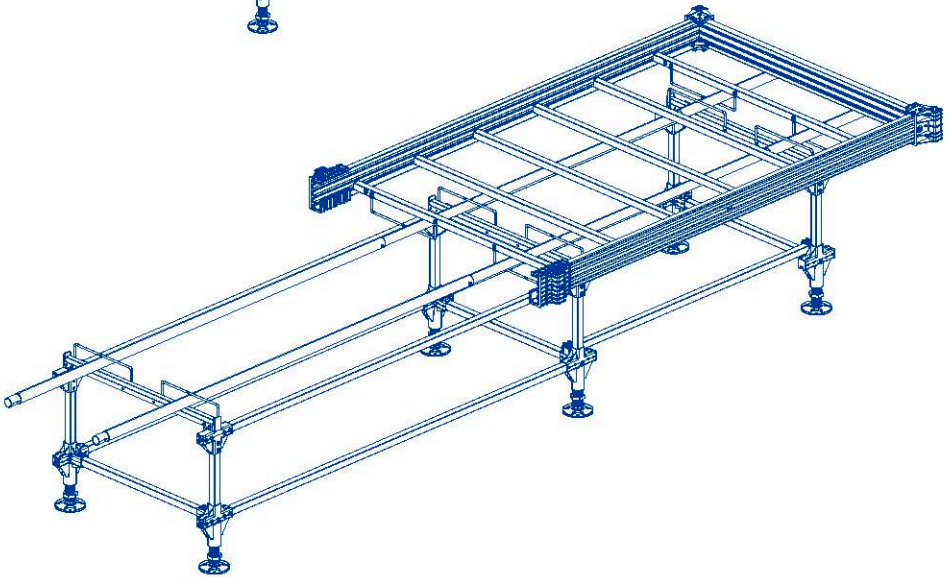
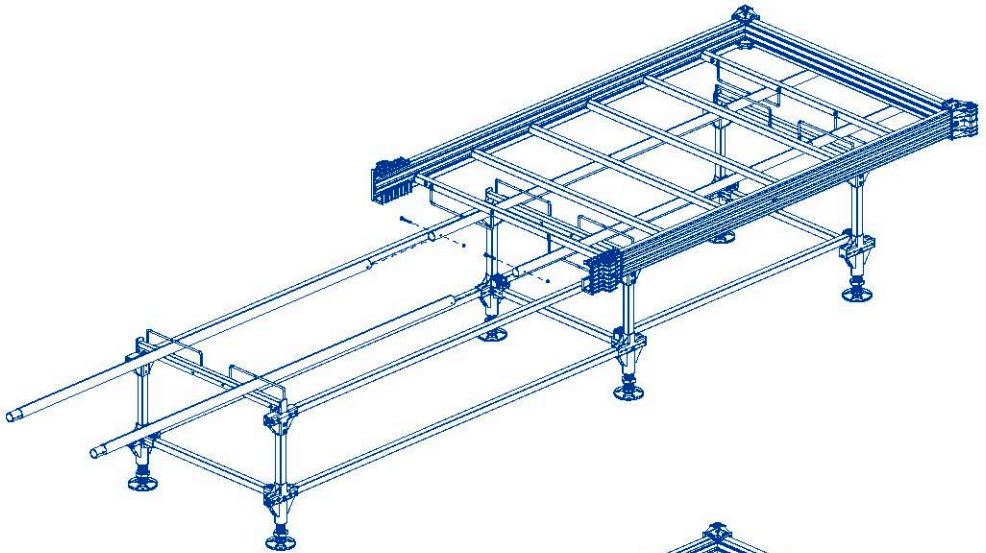

Kit A - Step 4

Part Qty

3 X12



4 X12



Part Qty

11 X1



12 X5



Part Qty

A-R X1



A-L X1

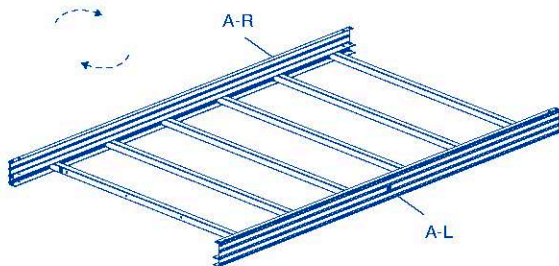
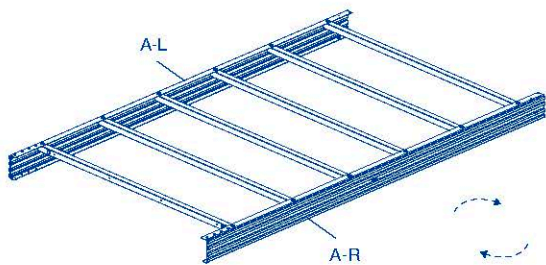
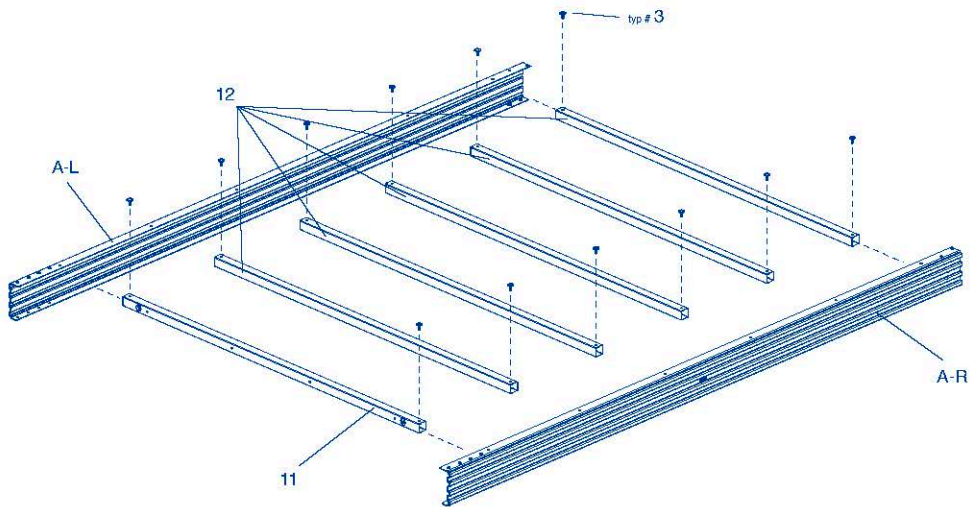

Kit A - Step 5

Part Qty

3 X8



4 X8



Part Qty

18 X4



Part Qty

X1



* For more informations, go to the **Kit A - Details** page.

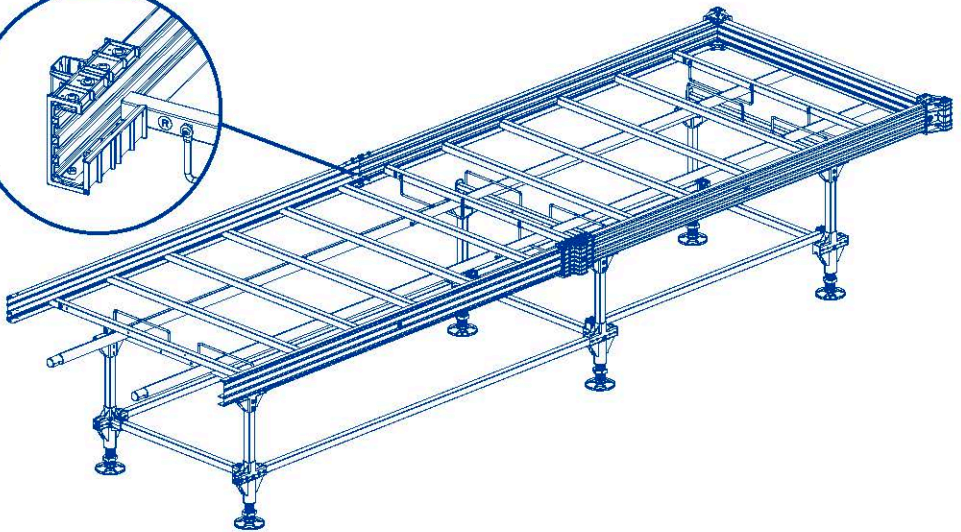
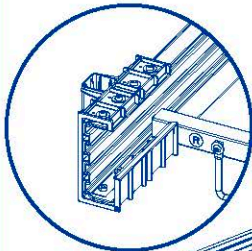
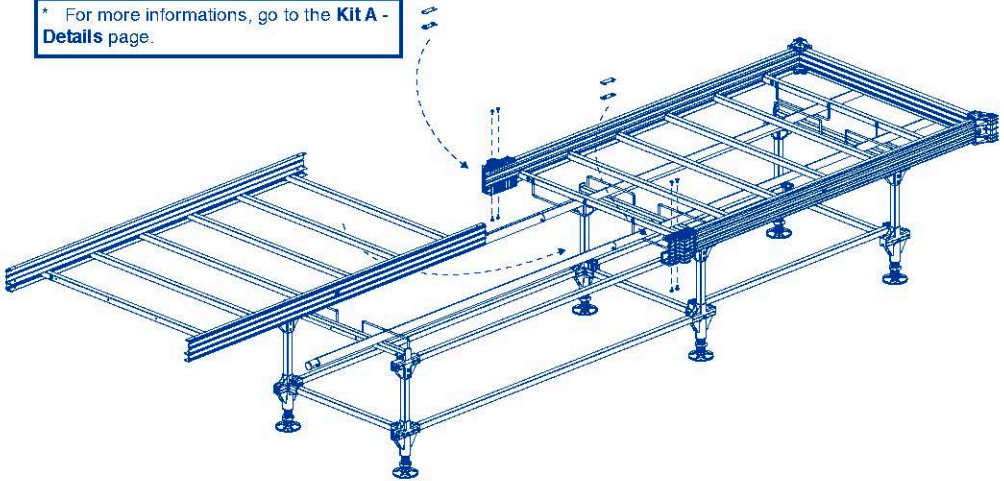

Kit A - Step 6

Part Qty

3 X4



Part Qty

C-1 X2

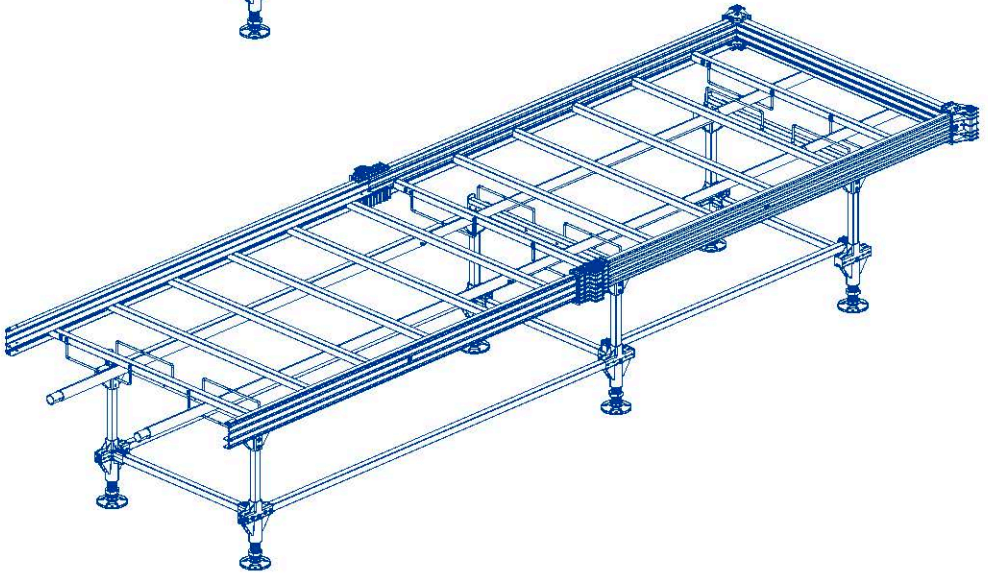
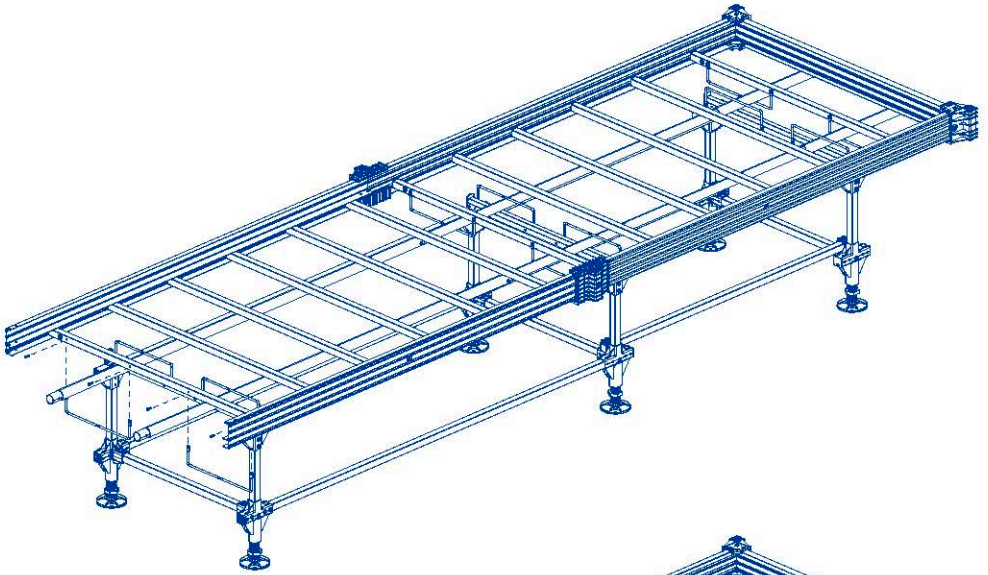

Kit A - Step 7

Part Qty

3 X8



4 X8



Part Qty

17 X4



A2 X2



Part Qty

X1



* For more informations, go to the **Kit A - Details** page.

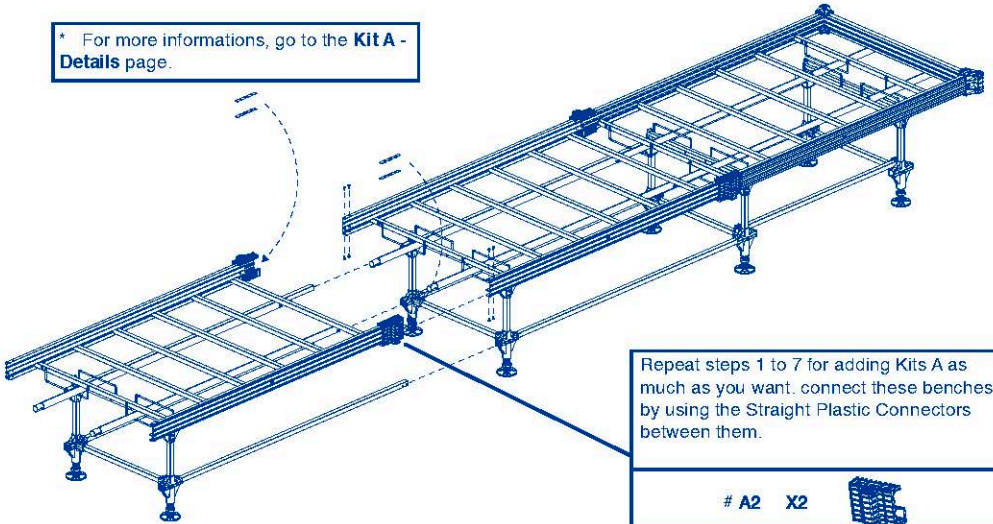

Repeat steps 1 to 7 for adding Kits A as much as you want, connect these benches by using the Straight Plastic Connectors between them.

A2 X2

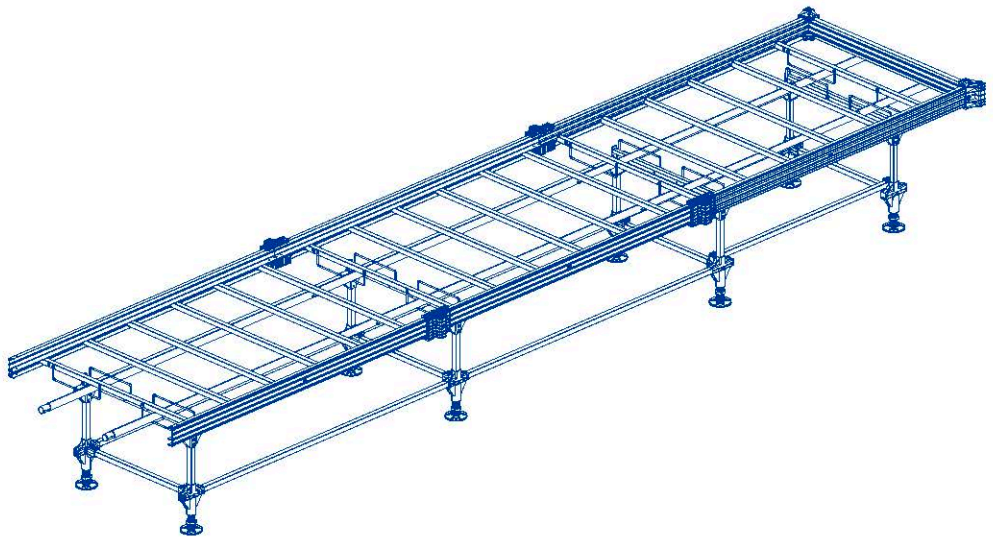

Kit A - Step 8

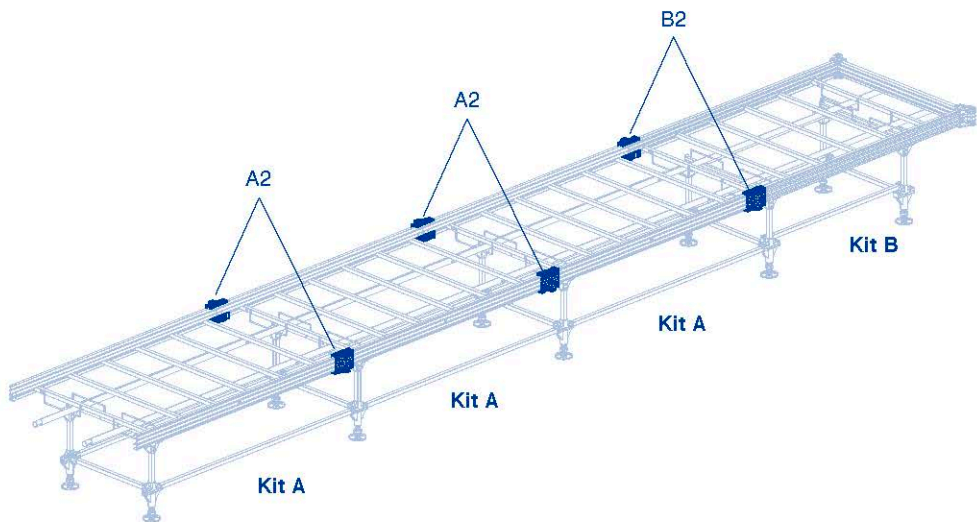

Kit A + Kit A

Use Straight Plastic Connectors (A2) to connect all the Kit A together.

Kit A + Kit B

Use Straight Plastic Connectors (B2) to connect a Kit A and a Kit B together.

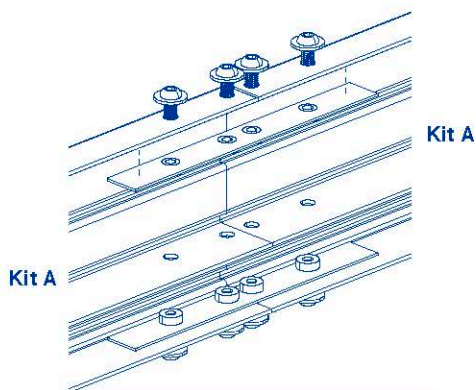

Kit A + Kit A

Use Straight Metal Connectors (#17) to connect all the Kit A together.

17 X4

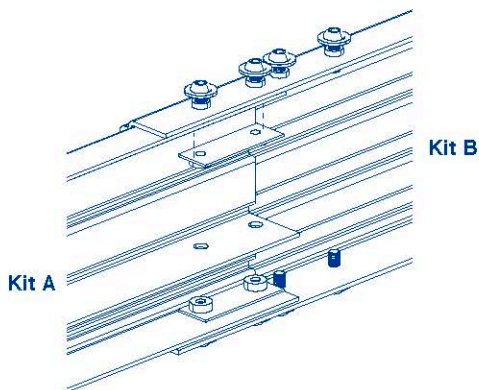

Kit A + Kit B

Use Straight Metal Connectors (#18) to connect a Kit A and a Kit B together.

18 X4



Kit A - Details

Part Qty

3 X4



4 X4



Part Qty

13 X4



A-A X1



Part Qty

A1 X2

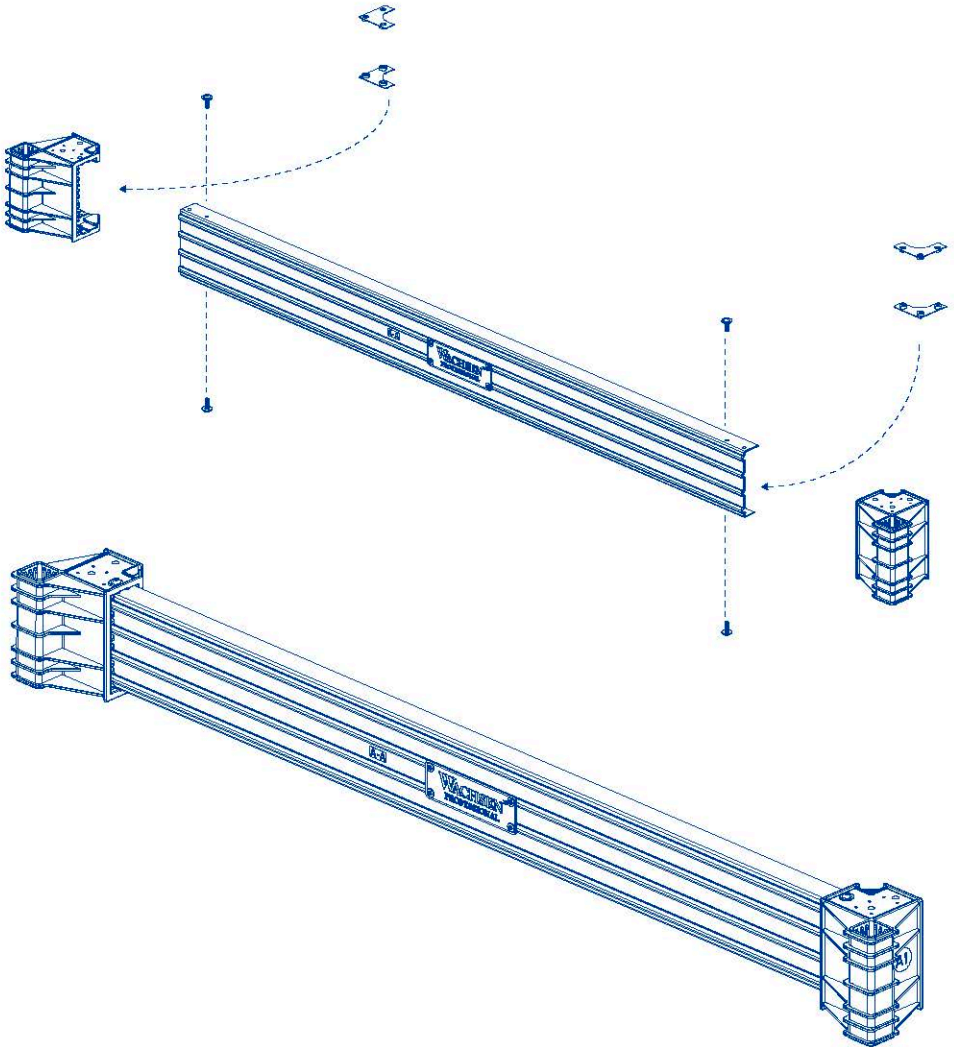

Kit A - Step 9

Part Qty

3 X8



Part Qty

4 X8



Part Qty

X1

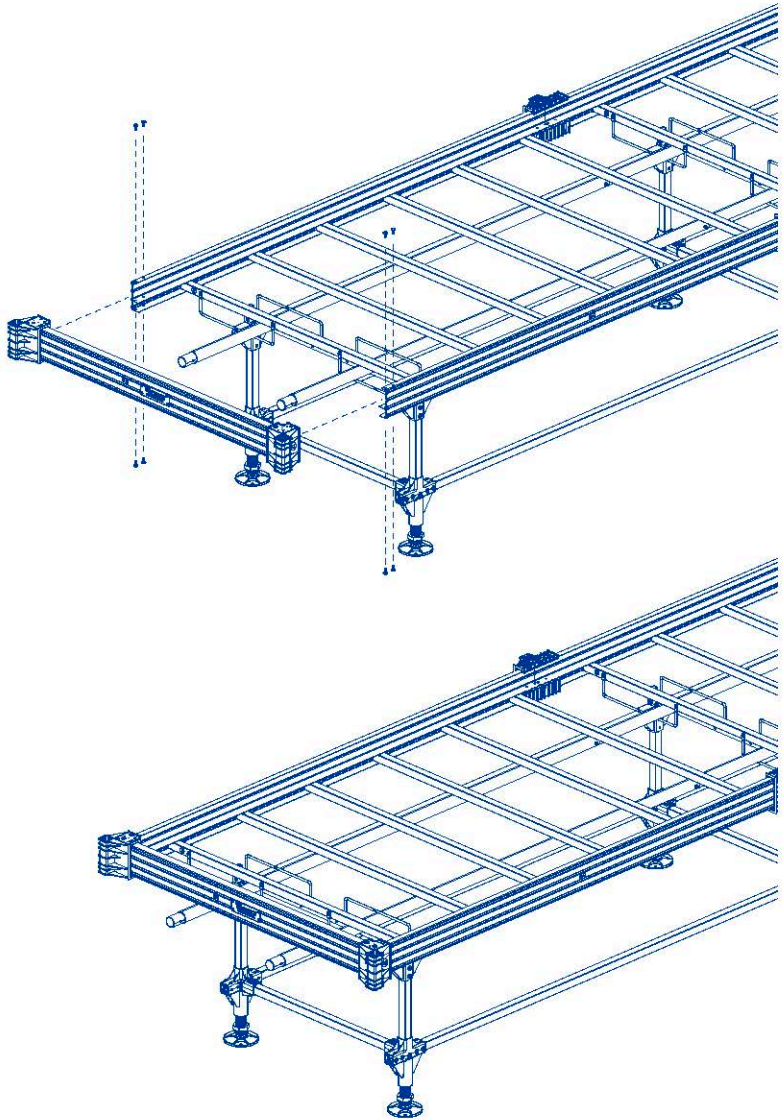

Kit A - Step 10

Part Qty

1 X1



2 X1



Part Qty

4 X1



19 X1



Part Qty

23 X1

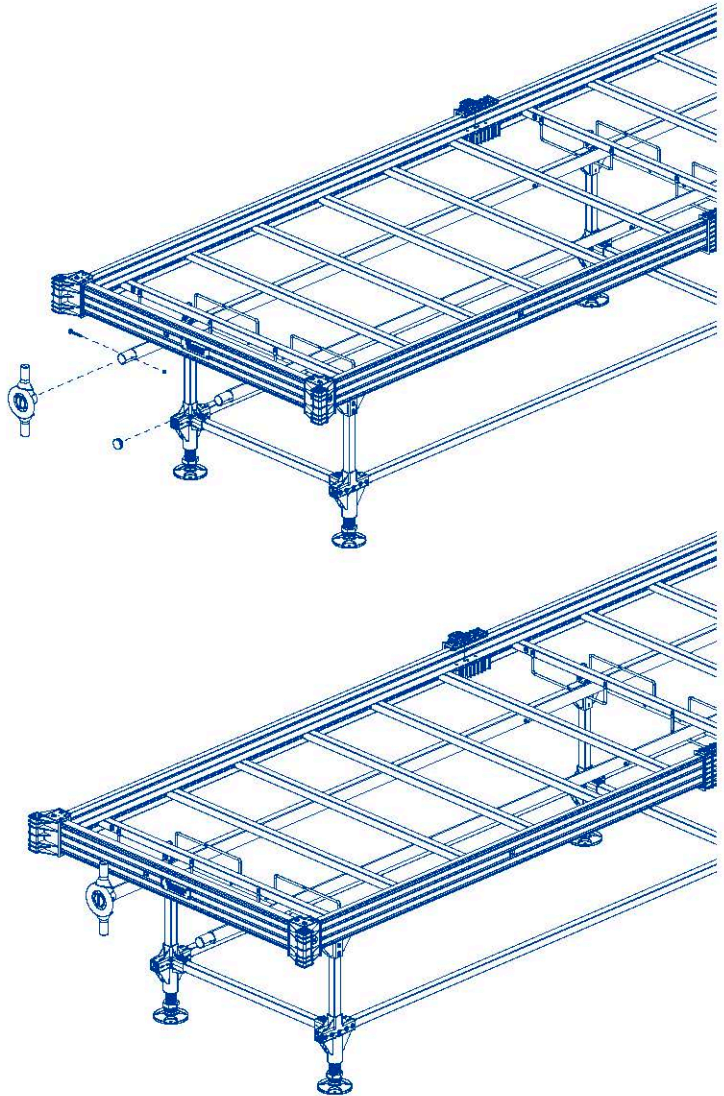

Kit A - Step 11

Part Qty

20 X4

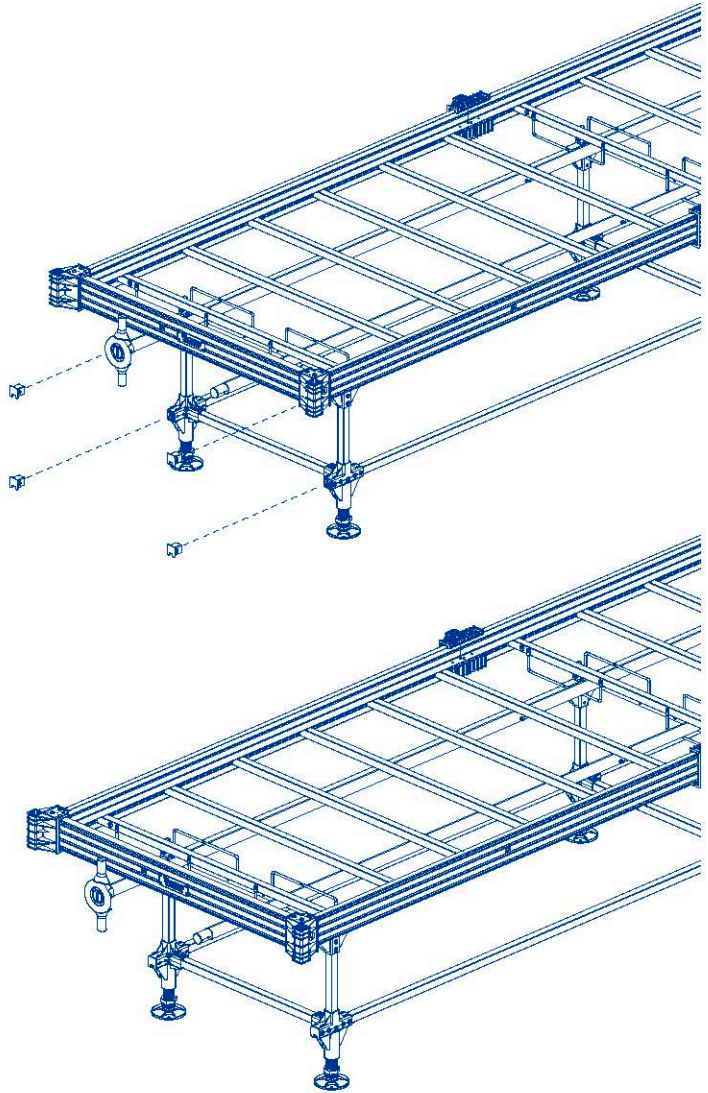

Kit A - Step 12

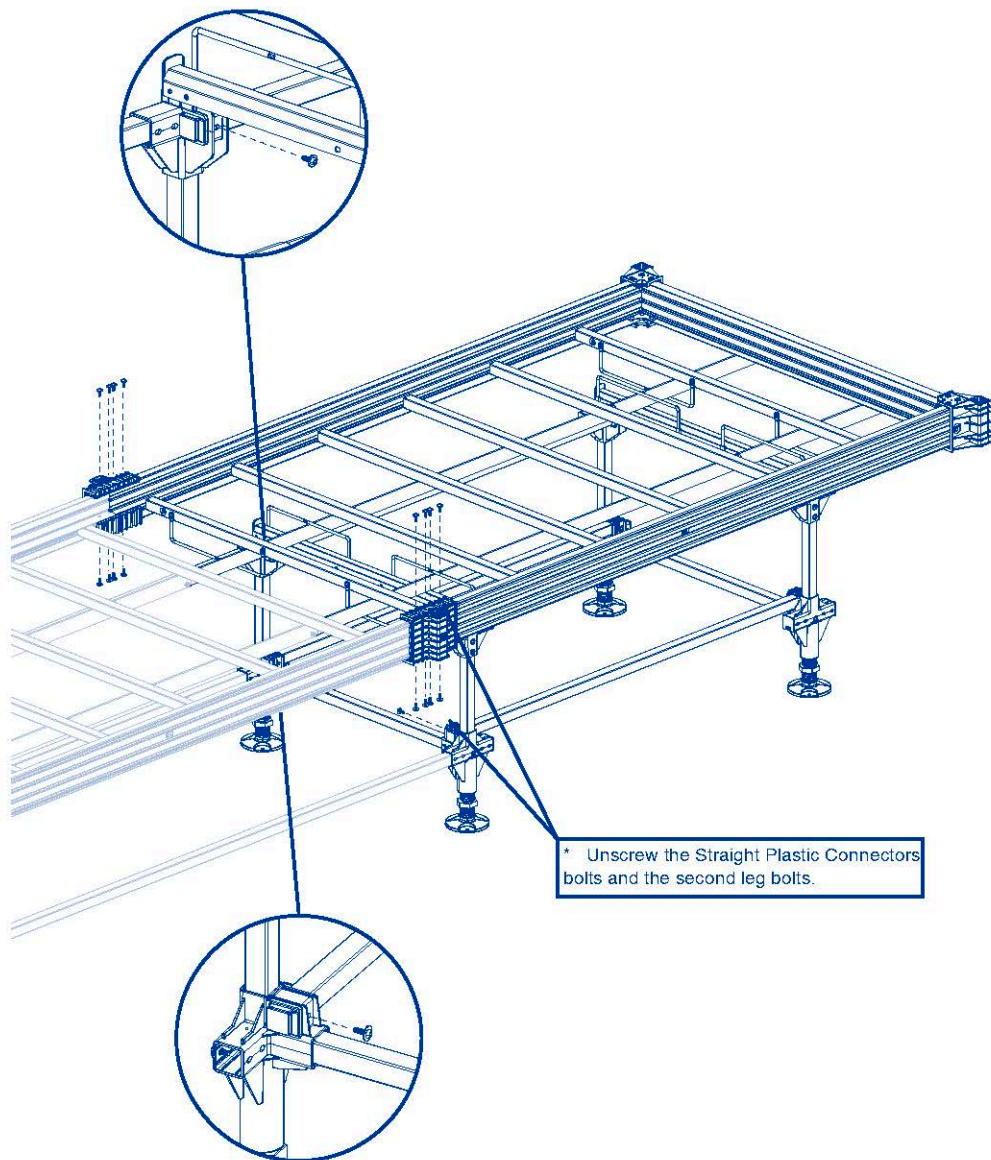

Kit B - Adjustment

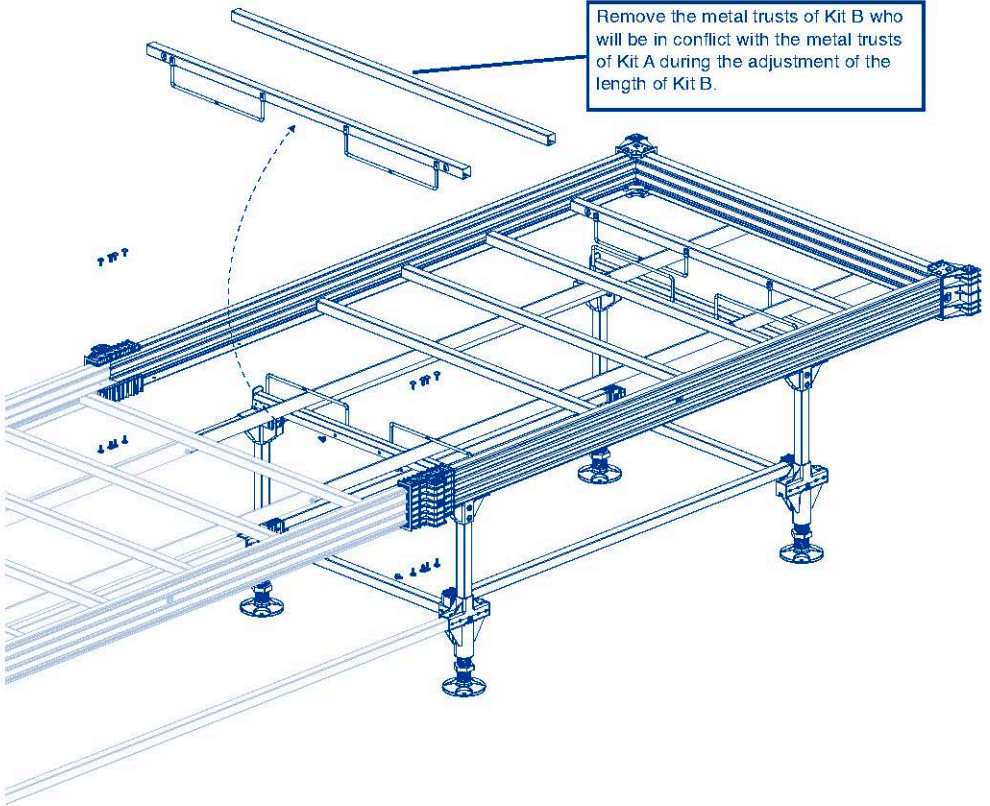

Kit B - Adjustment

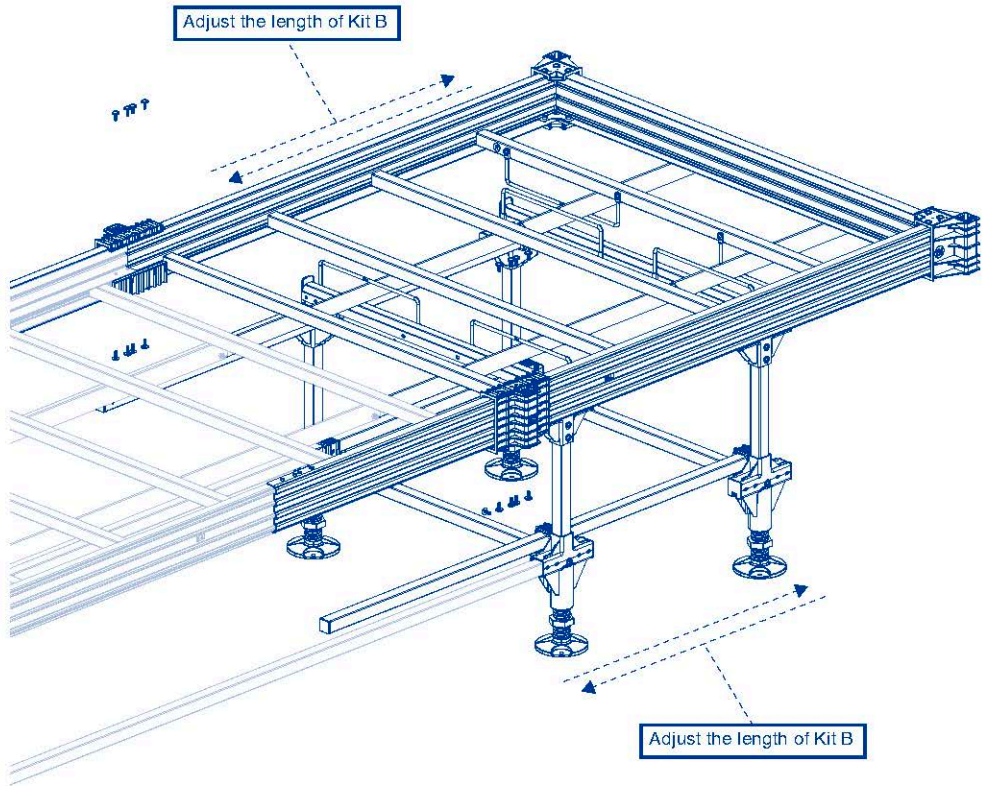

Kit B - Adjustment

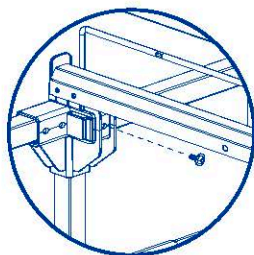

* If you want to re-screw the Straight Plastic Connectors bolts and the second leg bolts we suggest using self-tapping screws (not included).

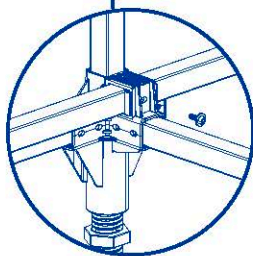
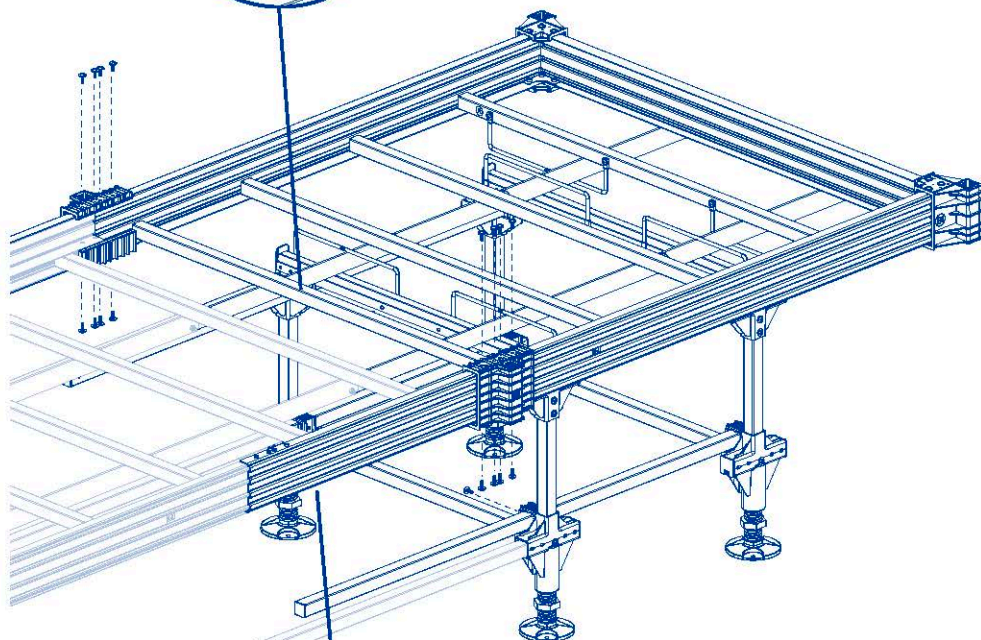

Kit B - Adjustment

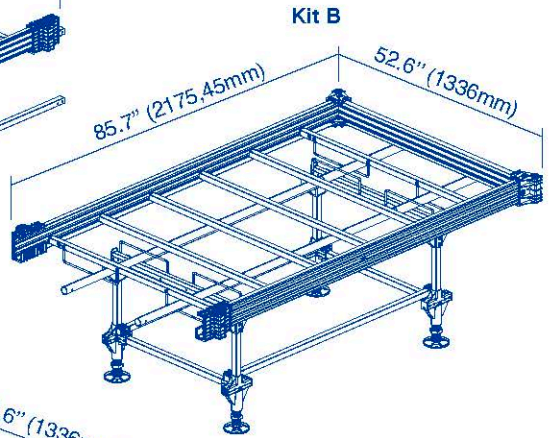
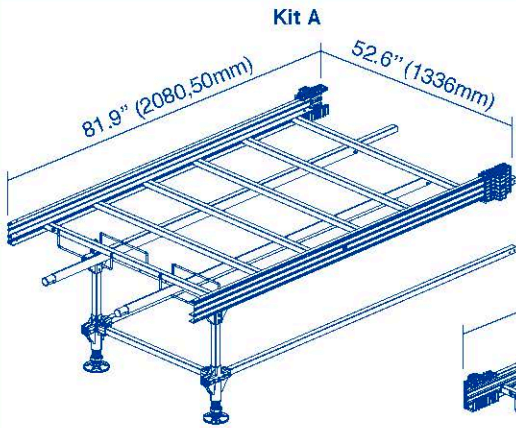

**Kit A + Kit B
Minimum length**

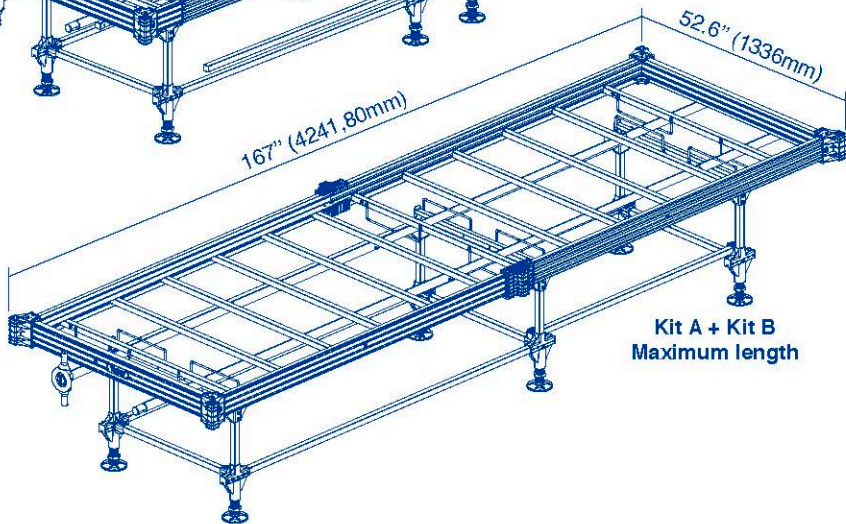
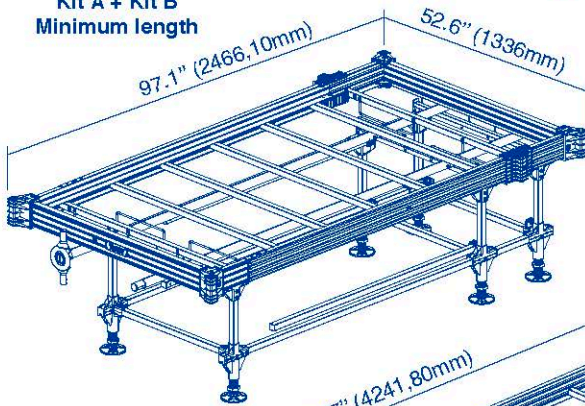



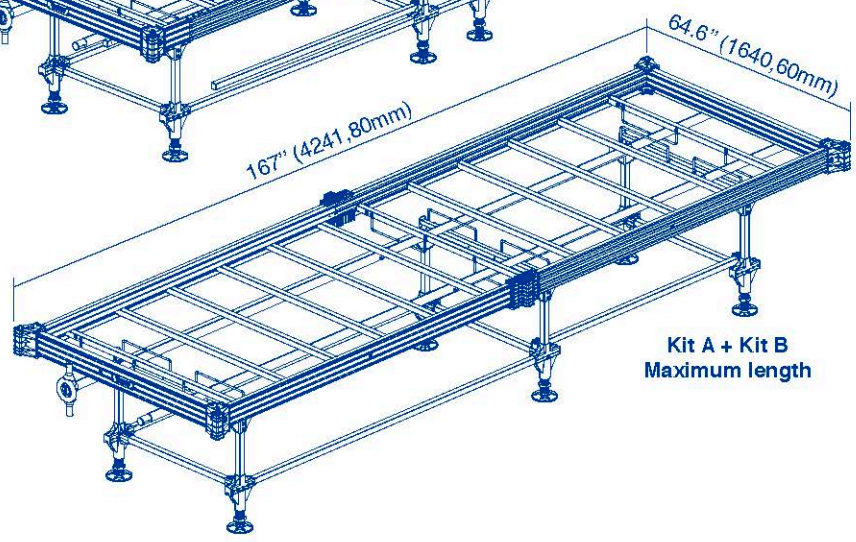
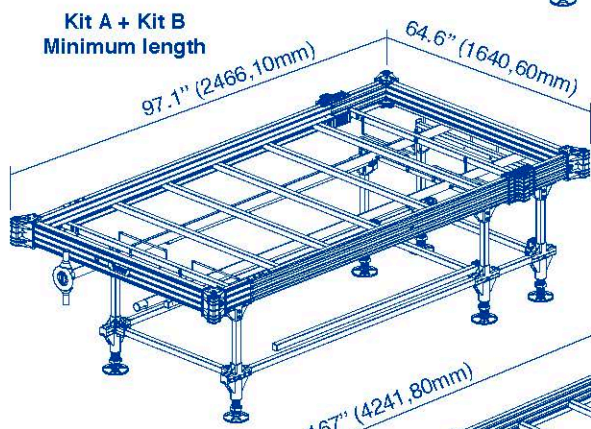
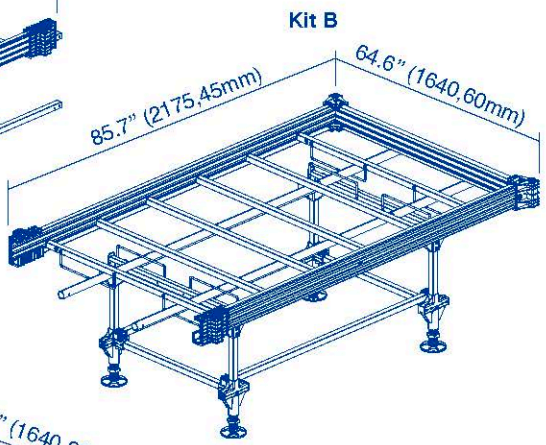
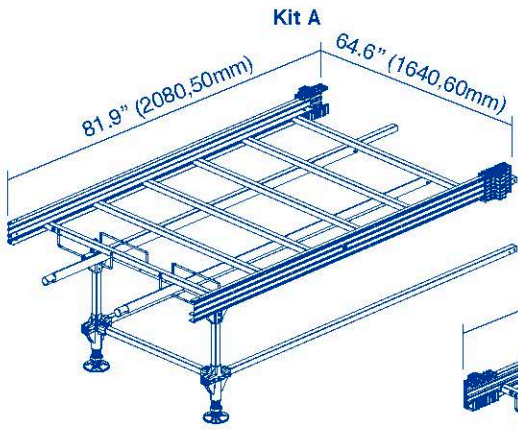







Kit A - 4'



Kit A - 5'

Parts from Kit B

The remaining parts need to be used to close the table when the length is determined.

Part	Qty	Description		Part	Qty	Description	
# 1	X1	Mounting Nut (M6)		# 19	X1	Turnable Handle	
# 2	X1	Mounting Bolt (M6*55L)		# A1	X2	Right Angle Plastic Connector	
# 3	X12	Mounting Bolt (M6*18L)		# A-A	X1	Aluminum Side	
# 4	X13	Mounting Washer		# 20	X4	Plastic Cap (41*41)	
# 13	X4	Right Angle Metal Connector		# 23	X1	Round Plastic Cap (D=38)	
# 18	X4	Straight Metal Connector	