



**idrolab**<sup>TM</sup>  
— HYDROPONICS —

# IDRORACK 3 ASSEMBLY INSTRUCTION



COMMERCIAL CULTIVATION SUPPLY  
[WWW.IDROLABHYDROPONICS.COM](http://WWW.IDROLABHYDROPONICS.COM)

# INTRODUCTION

## PRELIMINARY INDICATIONS

### BEFORE STARTING

Carefully read instructions before starting assembling your new modular cultivation bench.

### NOTE

Equip yourself in advance of the following tools, not included with the benches, to successfully and properly complete the assembly of your new modular cultivation bench:

- Battery-powered screwdriver with clutch
- Impact drill
- Glue gun
- Laser level
- Normal level
- Wire chalker
- Meter
- Detergent
- Clean cloths
- Cement anchors with fine hexagonal head screw
- Wrenches  
8mm – 10mm - 13mm
- Ratchets  
8mm – 10mm - 13mm
- Hexagonal socket wrenches  
8mm – 10mm – 13mm

### SETTING UP THE CLUTCH OF THE SCREWDRIVER

Use the lowest clutch level of the screwdriver. Once the head of the screw is in contact with the support surface, finish fastening manually with a wrench and a ratchet.

Be very careful when fastening screws with the battery-powered screwdriver. Excessive fastening will result in damaging the screw as well as the area of the support where you are fastening on.

### SAFETY PRECAUTIONS

Read and follow carefully all the information before starting the assembly. Not following the advises and instructions may result serious personal injuries, damage to products and to the environment where installation occurs.

- Modular cultivation bench must always be fastened with high-quality anchors on cement surface free of relevant signs of deterioration.
- Never load more than 150Kg/m<sup>2</sup> on the cultivation bench
- Use the modular cultivation bench only after you are sure to have successfully finished all of the assembling operations

Idrolab Hydroponics is not liable for any damaged caused to person and things from the improper use of the supplied materials.

# IDRORACK 3 START KIT

## COMPONENTS

X 120

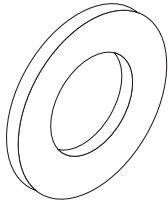

WASHERS M6

X 60

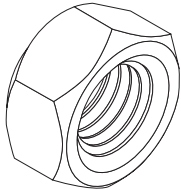

NUTS M6



X 12

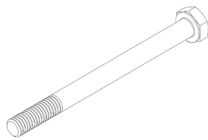

SCREWS M6X100

1

X 24

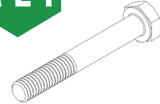

SCREWS M6X70

2

X 24



SCREWS M6X40

3

X 4

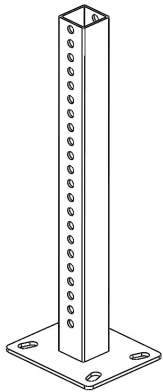

LEG

4

X 6

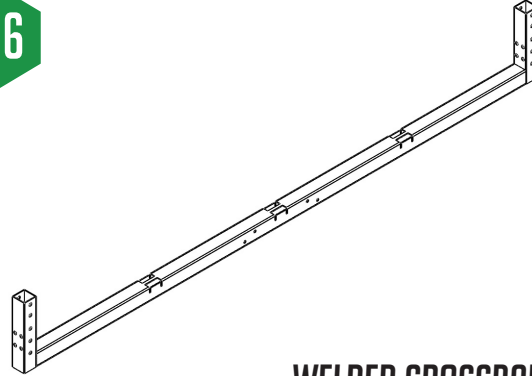

WELDED CROSSBAR

5

X 6



SIDE BOARD 1010MM

6

X 9

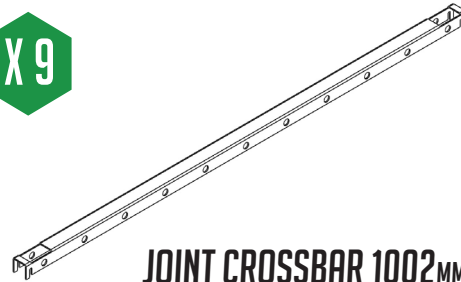

JOINT CROSSBAR 1002MM

7

X 4



CURRENTS 2065MM

8

# IDRORACK 3 MODULAR KIT

## COMPONENTS



X 84

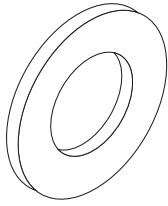

WASHERS M6

X 42

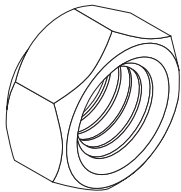

NUTS M6

X 6

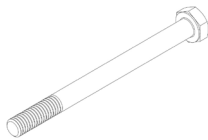

SCREWS M6X100

1.1

X 12

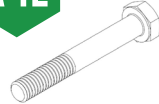

SCREWS M6X70

1.2

X 24



SCREWS M6X40

1.3

X 2

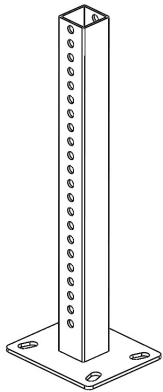

LEG

1.4

X 3

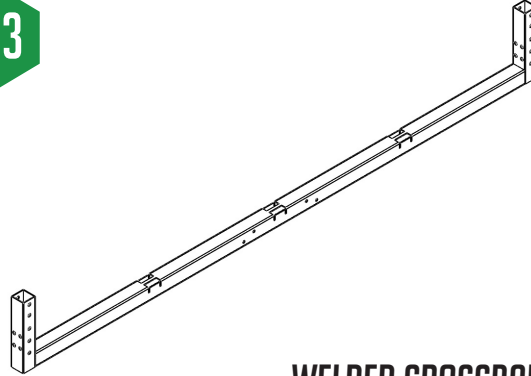

WELDED CROSSBAR

1.5

X 6



SIDE BOARD 1200MM

1.6

X 9

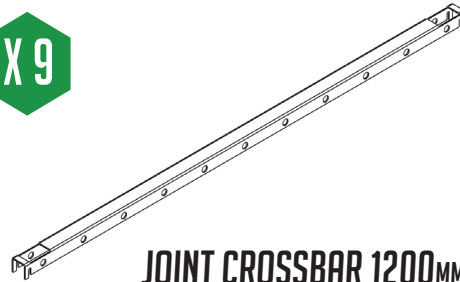

JOINT CROSSBAR 1200MM

1.7

X 2



CURRENTS 2065MM

1.8

# IDRORACK 3 END KIT

## COMPONENTS

X 42

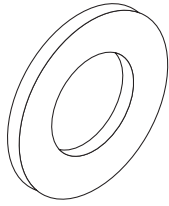

WASHERS M6

X 84

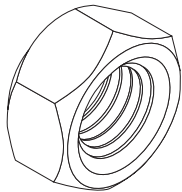

NUTS M6



X 6

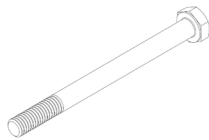

SCREWS M6X100

2.1

X 12

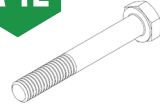

SCREWS M6X70

2.2

X 24



SCREWS M6X40

2.3

X 2

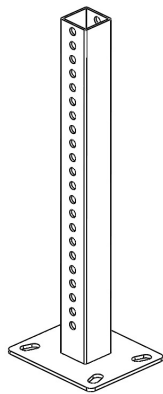

LEG

2.4

X 3

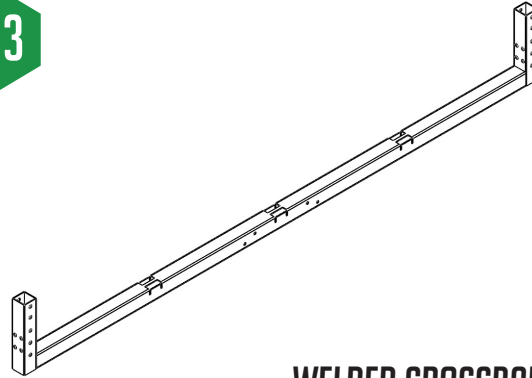

WELDED CROSSBAR

2.5

X 6



SIDE BOARD 1010MM

2.6

X 9

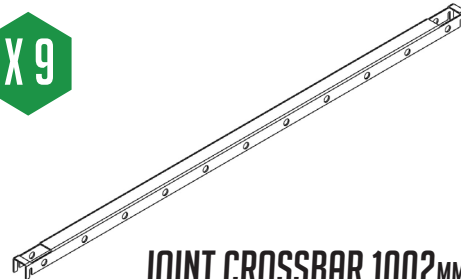

JOINT CROSSBAR 1002MM

2.7

X 2



CURRENTS 2065MM

2.8

# SIZING

## COMPONENTS

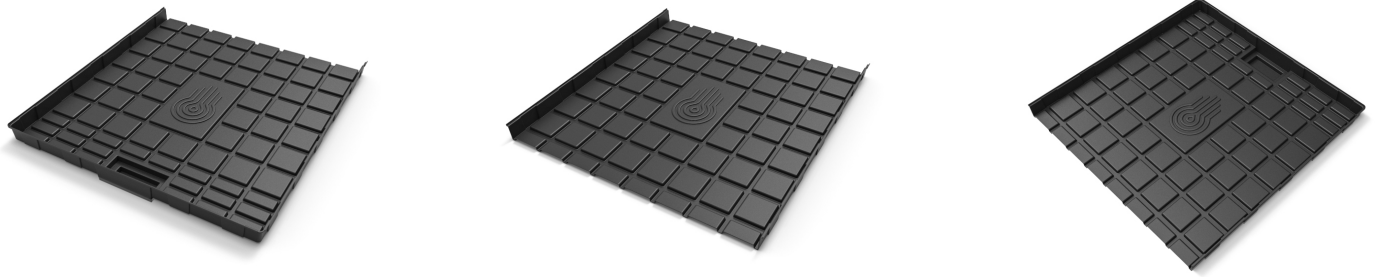

The bench modules are designed to host our modular trays.

Also the modular trays are provided in different types: start, module, end.

Each tray is 1200mm x 1200mm in size. Example in Fig. 1 shows sizing of 3x assembled trays.

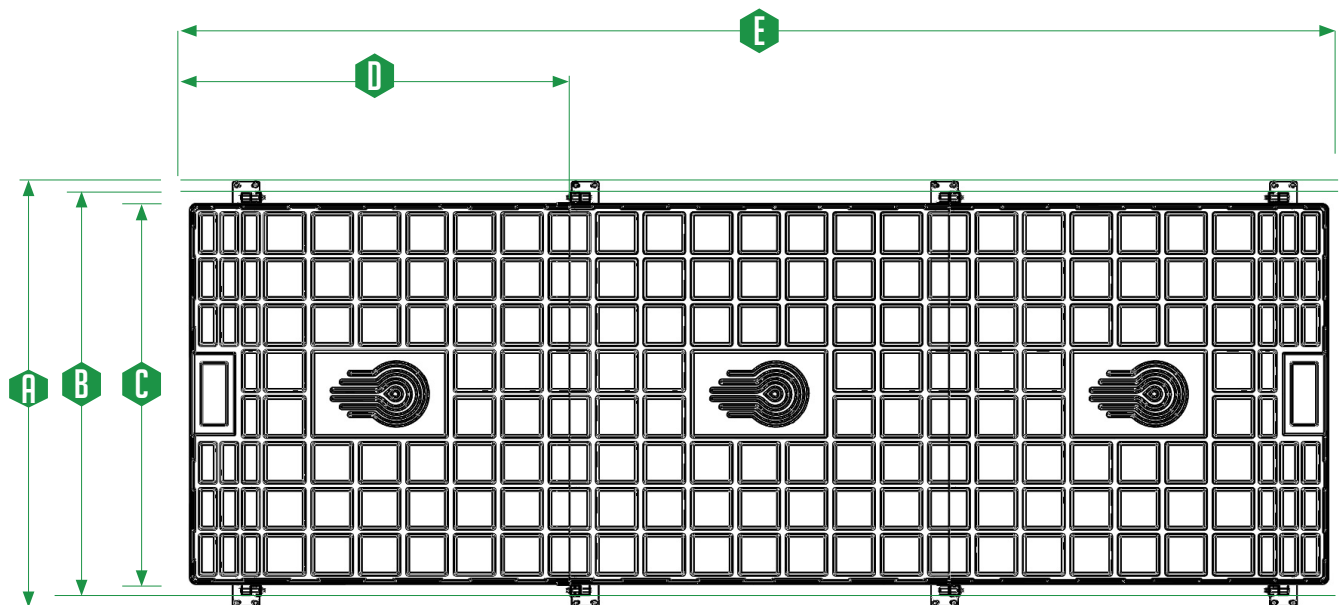

Fig. 1

**A** LEG SIZE: 1335MM

**B** FRAME SIZE: 1265MM

**C** TRAY LEHTH: 1200MM

**D** TRAY WIDTH: 1200MM

**E** ASSEMBLED TRAYS SIZE: 1200MM X3 =3600MM



# ASSEMBLING THE STARTING FRAME

STEP 1

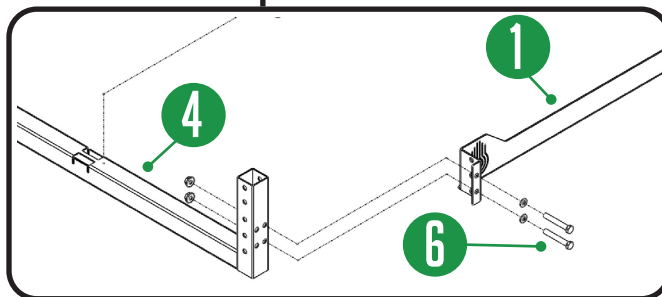
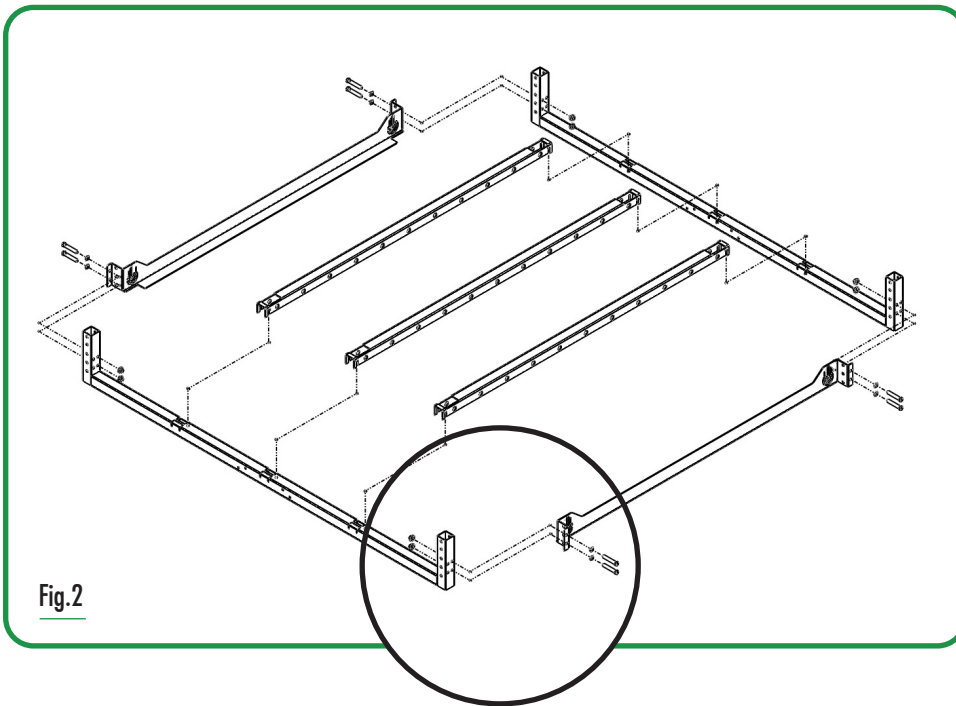

1.1 Fasten with two screws the edge of the side board (1) to the welded crossbar (4) using the external screw holes as shown in fig.2

1.2 Fasten with two screws the free edge of the side board (1) to the other welded crossbar (4) using the external screw holes as shown in fig. 2

1.3 Repeat the same operations also on the second joint crossbar (1)

1.4 Place the joint crossbars (2) in their specific enclosures found in welded crossbars (4) as shown in fig.3

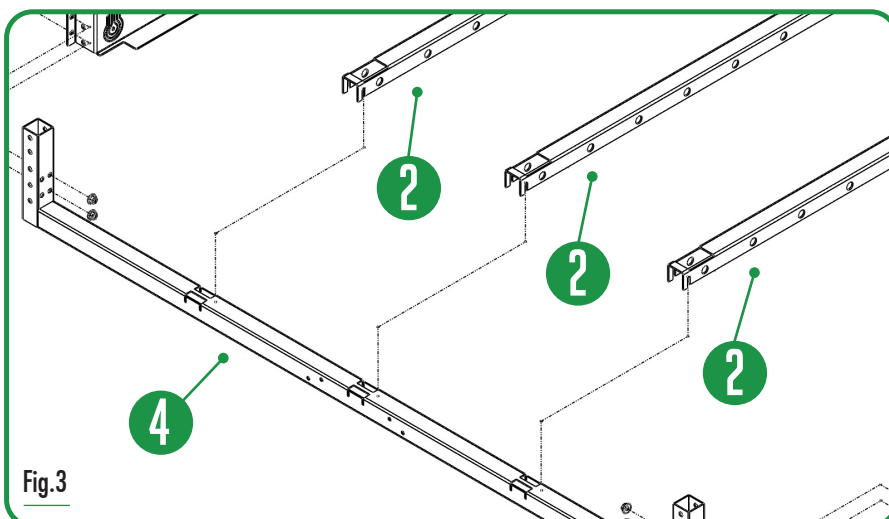

# ASSEMBLING THE STARTING FRAME

## STEP 1.1

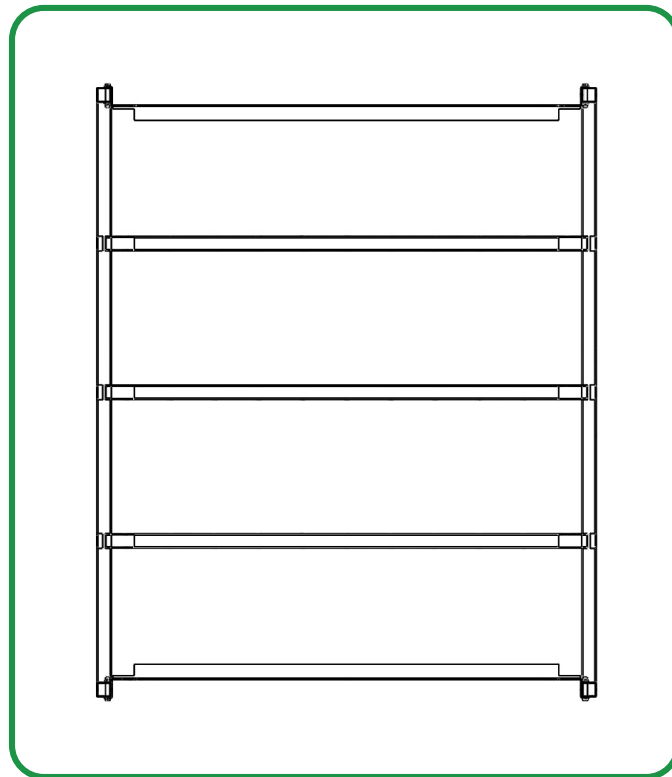
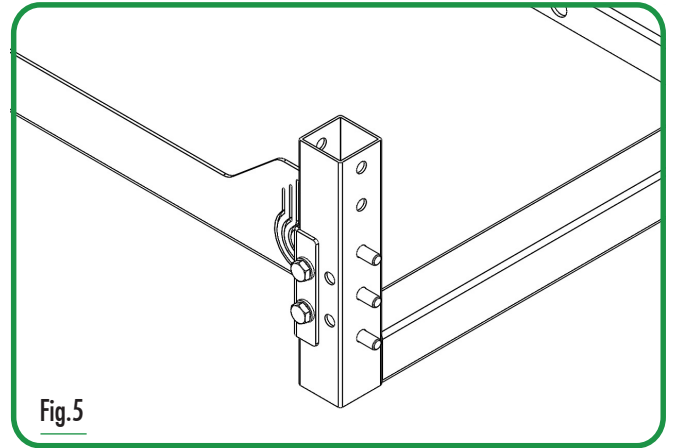
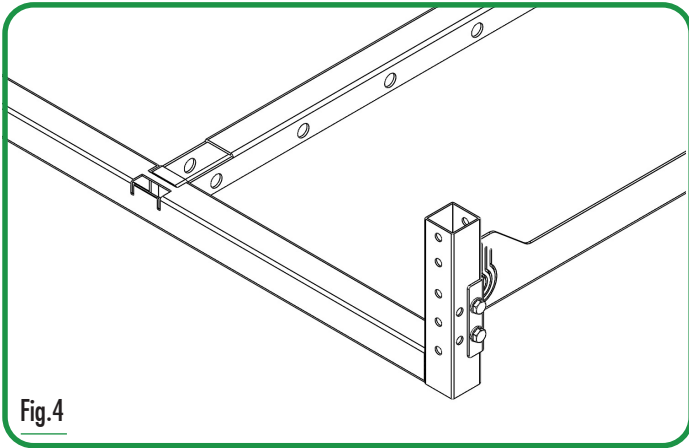



# ASSEMBLING THE MODULE FRAME

STEP 2

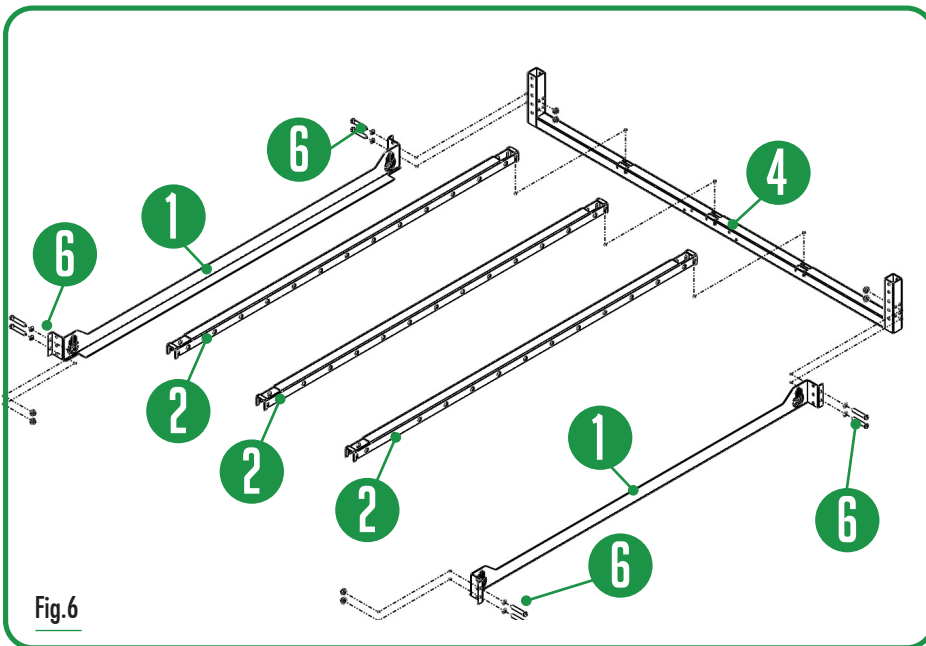
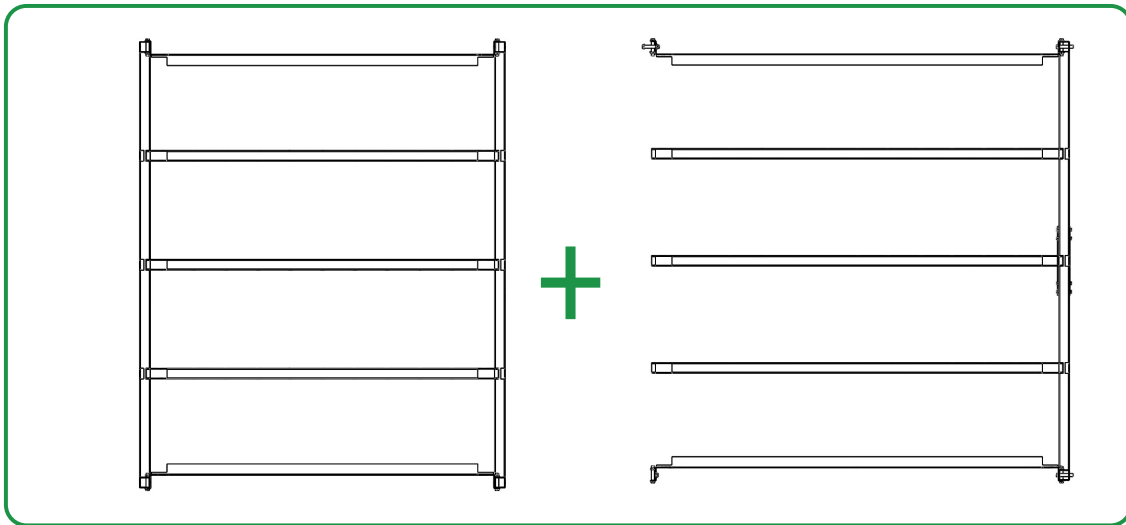

Fig.6

- 2.1 Fasten with two screws the edge of the side board (1) to the welded crossbar (4) using the two external screw holes on the welded crossbar included in the kit by leaving free the other edge of the side board (1) as shown in [fig.6](#)
- 2.2 Repeat the same operation also for the other side board (1) included in the kit.
- 2.3 Fasten with two screws the free edge of the side board (1) to the free edge of the welded crossbar (4) previously assembled in the start frame (step1) as shown in [fig.7](#)
- 2.4 Repeat the same operation also for the second side board (1) included in the kit.
- 2.5 Place the joint crossbars (2.1) in their specific enclosures found in welded crossbars (4) as shown in [fig.6](#)

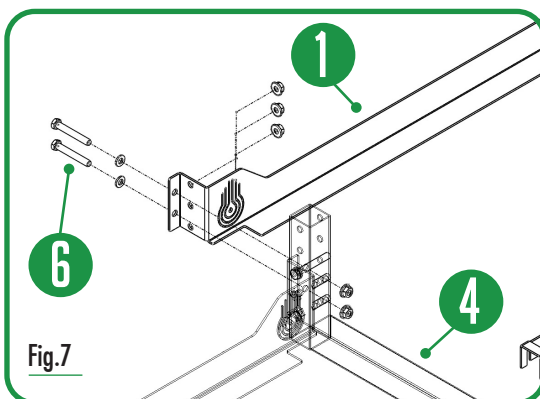

Fig.7

# ASSEMBLAGGIO TELAIO MODULAR

## STEP 2.1

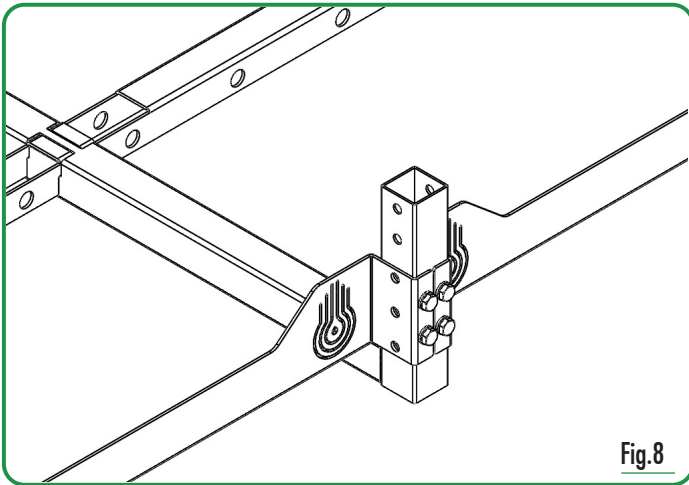

Fig.8

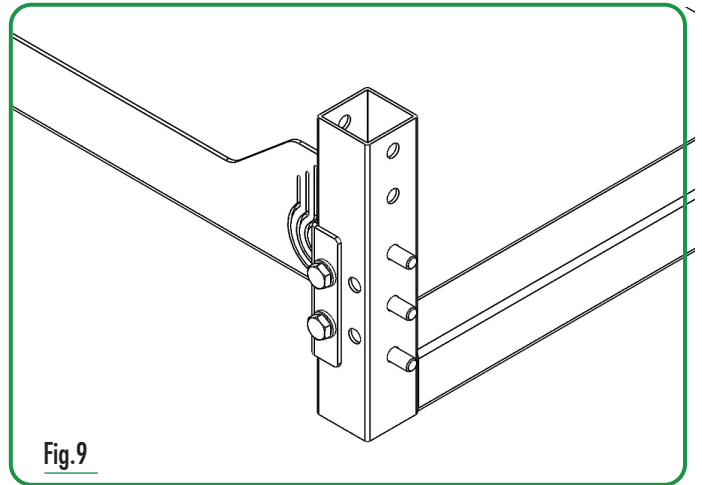

Fig.9

### NOTE

The assembling instructions for modular frame have to be repeated a number of times equal to the number of modular frame you have purchased. Before assembling the end frame all the modular frame must have been assembled.

Example:

⬡ IDRORACK 120x240 = 1 start frame + 1 end frame

⬡ IDRORACK 120x480 = 1 start frame + 2 modular frame + 1 end frame

⬡ IDRORACK 120x360 = 1 start frame + 1 modular frame + 1 modular end

⬡ IDRORACK 120x1800 = 1 start frame + 13 modular frame + 1 end frame

If you are assembling a table of large dimensions, it will be necessary to divide the assembly of the frames into several segments that can be handled by two people. The segments will be aligned and coupled when the legs are assembled as shown in the STEP. 4

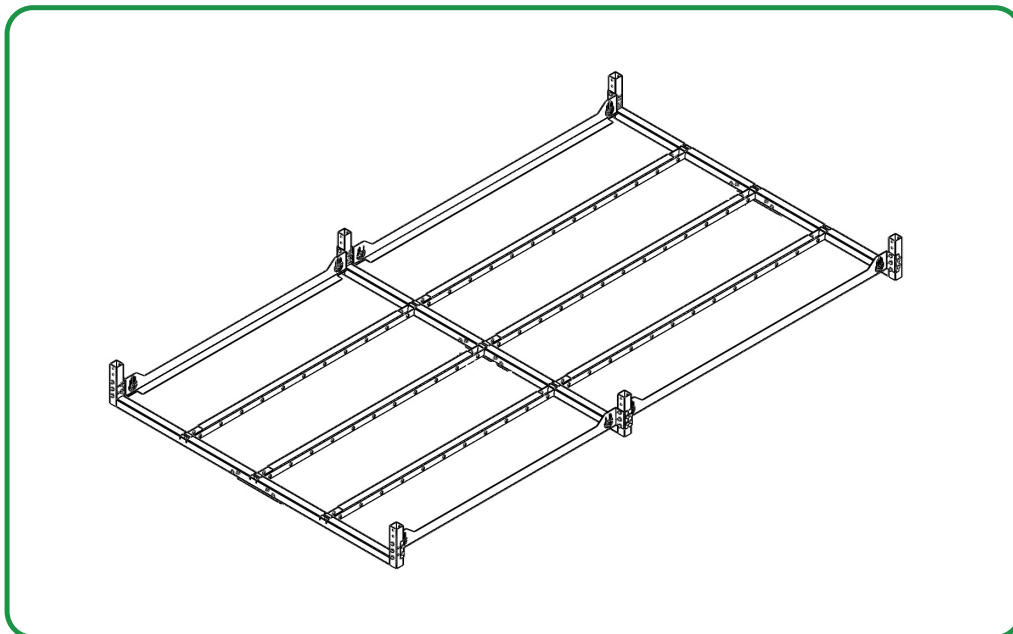

# ASSEMBLING THE END FRAME

STEP 3

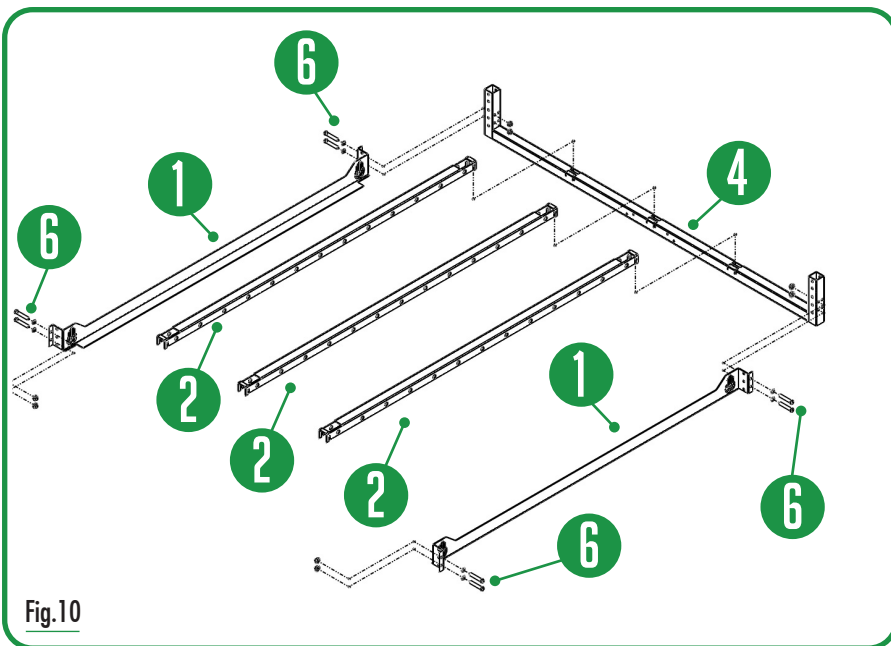
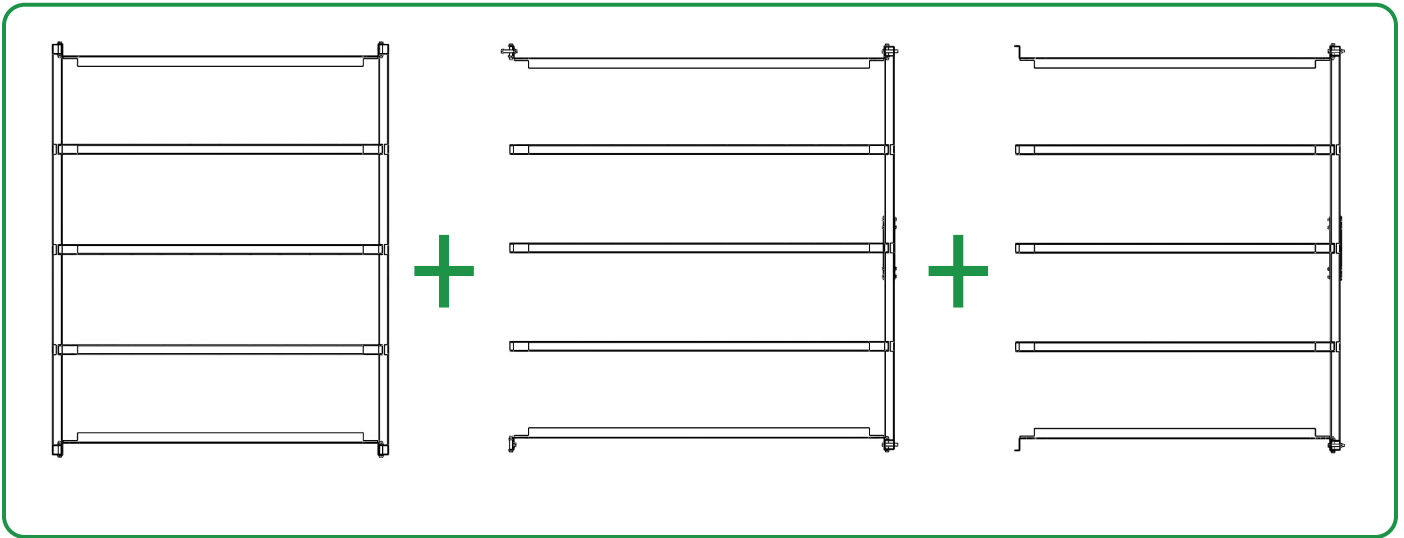

Fig.10

**3.1** Fasten with two screws the edge of the side board (1) to the welded crossbar (4) using the two external screw holes on the welded crossbar included in the kit by leaving free the other edge of the side board (1) as shown in [fig.10](#)

**3.2** Repeat the same operation also for the other side board (1) included in the kit.

**3.3** Fasten with two screws the free edge of the side board (1) to the free edge of the welded crossbar (4) previously assembled in the module frame (step2) as shown in [fig.11](#)

**3.4** Repeat the same operation also for the second side board (1) included in the kit.

**3.5** Place the joint crossbars (3) in their specific enclosures found in welded crossbars (4) as shown in [fig.10](#)

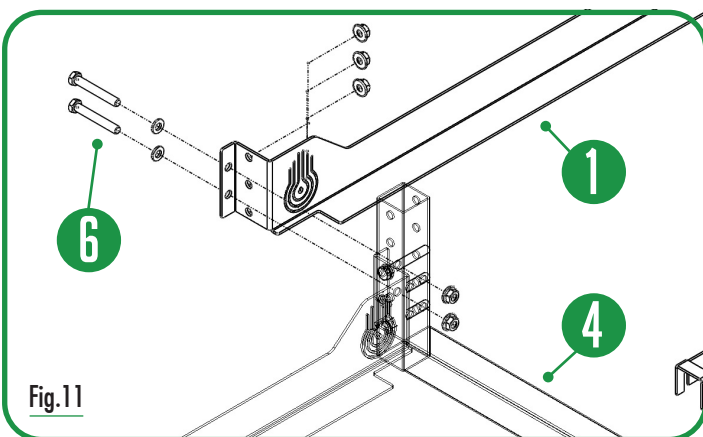
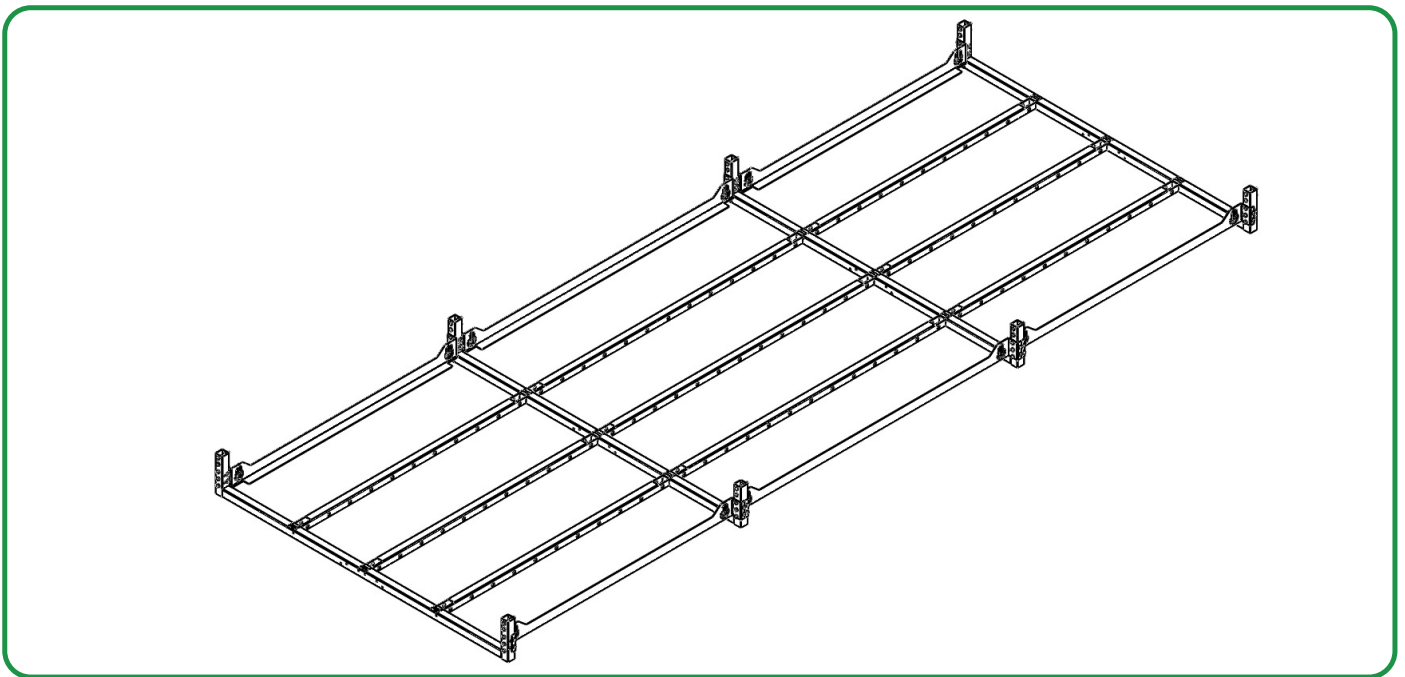
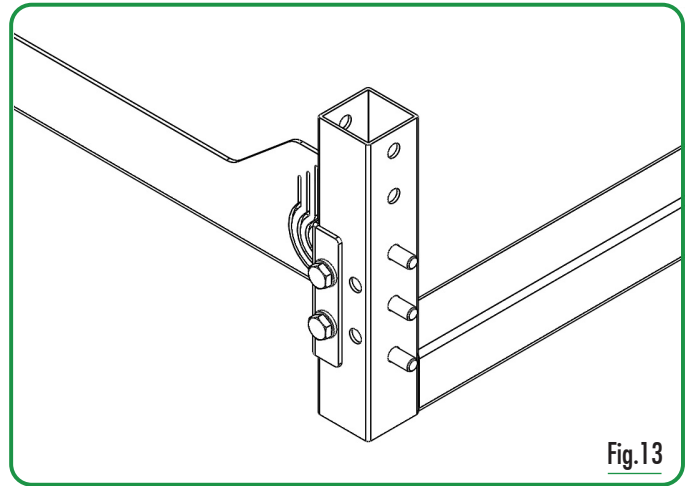
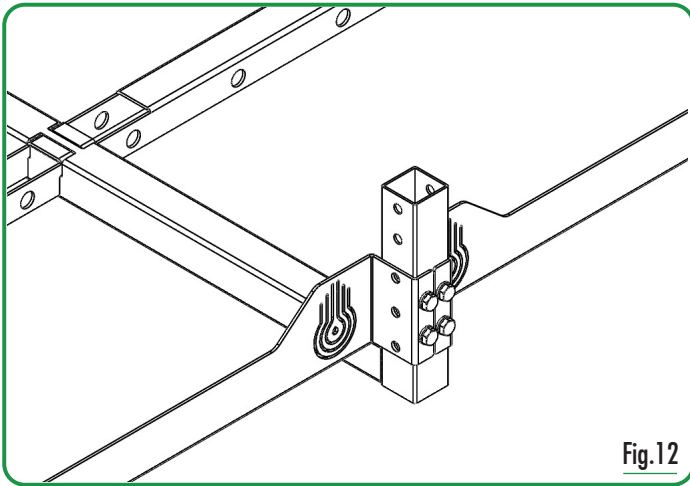

Fig.11

# ASSEMBLING THE END FRAME

## STEP 3.1



# ASSEMBLING THE LEGS ON THE FRAME

STEP 4

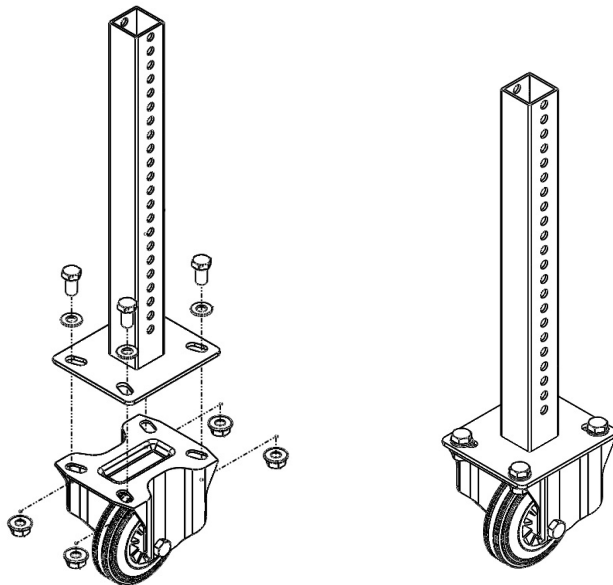

Fig.14

## NOTE

All the legs of the grow bench are produced with a support to enclose commercial wheels to make your bench movable. Wheels can be purchased separately and are not included in the kits. Assembling is shown in [fig.14](#).

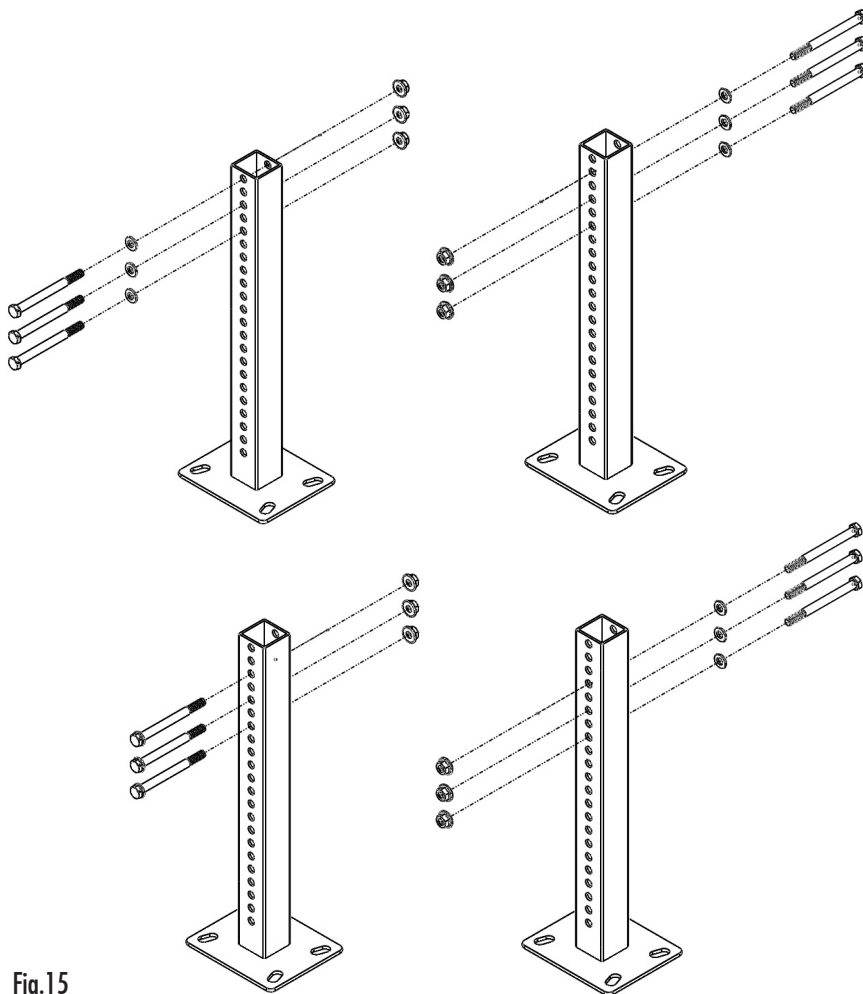

Fig.15

## NOTE

Through the legs you will provide your cultivation bench the right slope for the drainage of the waste solution out of the trays. Legs are designed with pass-through holes 1 cm from each other across all the height of the leg.

As shown in [fig.15](#) the first pair of legs has to be fastened to the frame with 3 screws positioned at the 3 highest pass-through holes of the leg, leaving one hole free between each screw. Subsequent pairs of legs must be fastened to its frame by scaling down one position (start from the second pass-through hole for the second pair of legs, the third pass-through hole for the third pair of legs etc.

# ASSEMBLING THE LEGS ON THE FRAME

## STEP 4.1

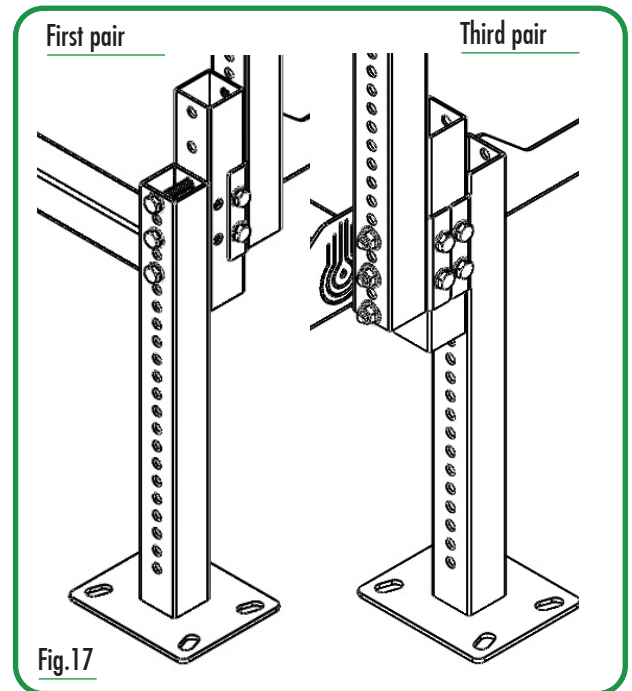
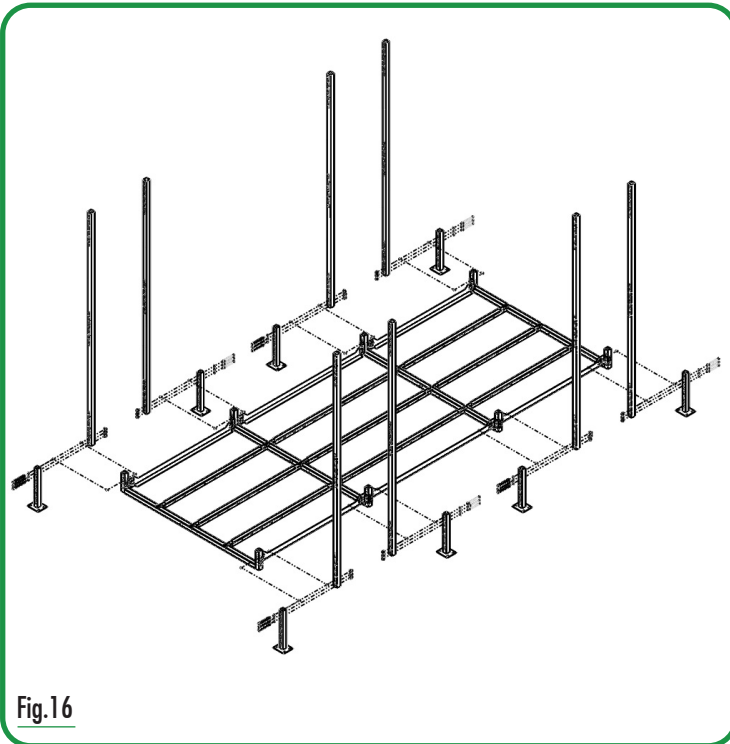

4.1 The aid of external supports (easels, stands) to support the frame will greatly facilitate the assembly of the legs.

4.2 Fasten with 3 screws in pass-through holes 1, 3 and 5 the first pair of legs on the external side of the first welded crossbar of the start frame (Fig. 16) as shown in Fig. 17

4.3 Fasten with 3 screws in pass-through holes 2, 4 and 6 the second pair of legs on the external side of the second welded crossbar of the module frame (Fig. 16) as shown in Fig. 17

4.4 Fasten with 3 screws in pass-through holes 3, 5 and 7 the third pair of legs on the external side of the third welded crossbar of the modular frame (Fig. 16) as shown in Fig. 17.

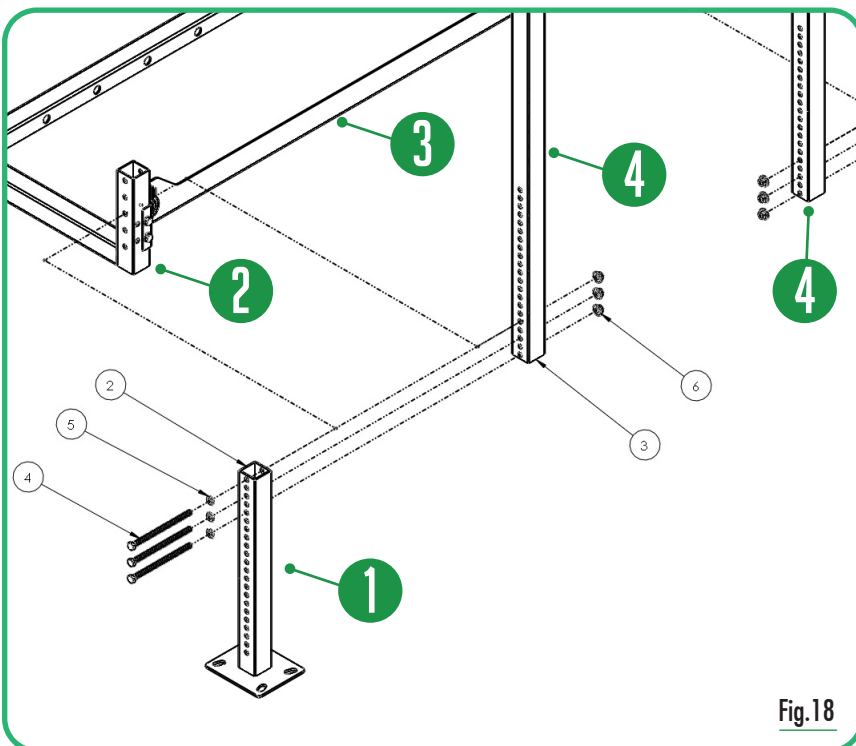

# ASSEMBLING THE LEGS ON THE FRAME

STEP 4.2



Fig.19

Once all the legs are correctly assembled in to the frame as shown in Fig. 18, there will be a slope of 1 cm every 120cm of length as shown in Fig. 20-21. The waste solution will easily reach the drainage without leaving any residue.

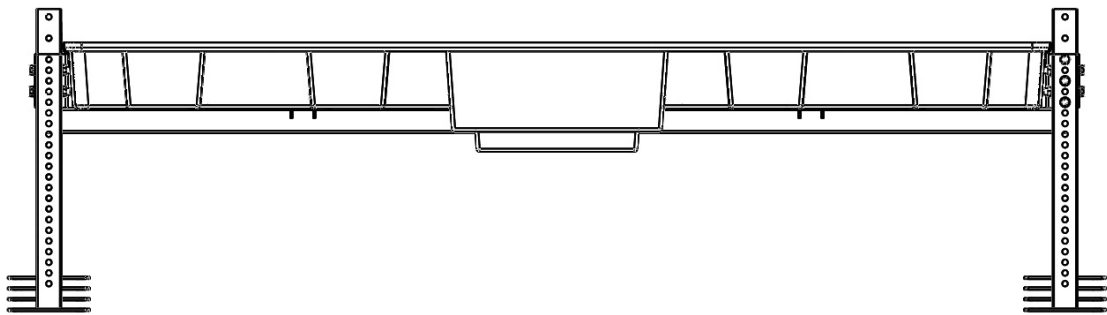

Fig.20

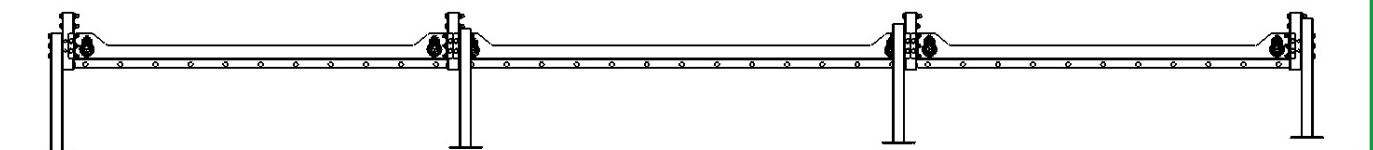

Fig.21



# ASSEMBLING SECOND LEVEL FRAME

## STEP 5

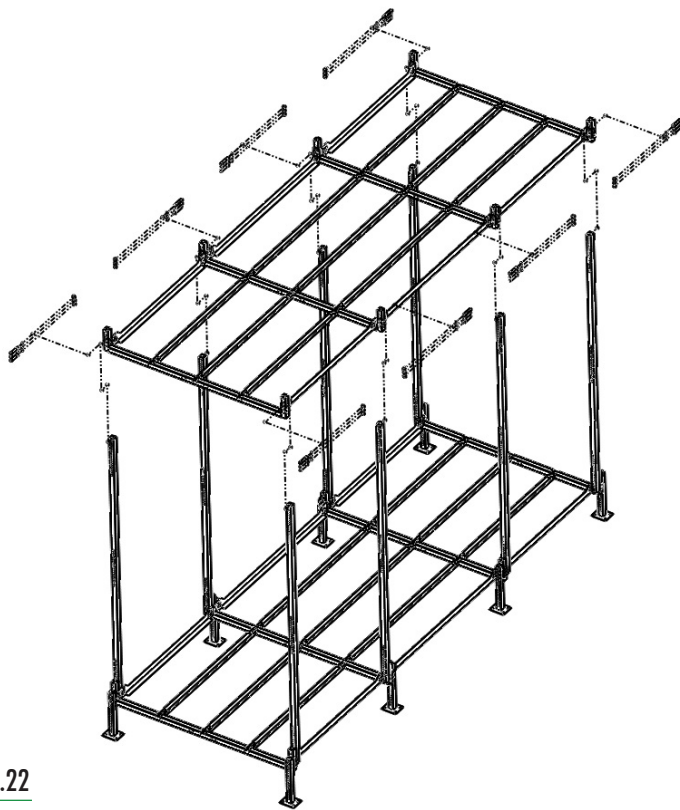

Fig. 22

5.1 Fix the pole to the first welded crossbar of the start frame of the second level with 3x bolt. ensure to include the side rail (1) correctly in the fixture as shown in Fig 22-25

5.2 Fix the pole to the second welded crossbar of the start frame of the second level with 3x bolt. ensure to include the side rail (1) correctly in the fixture as shown in Fig 22

5.3 Fix the pole internally to the first welded crossbar of the module frame of the second level with 3x bolt. ensure to include the side rail (1) correctly in the fixture as shown in Fig 22-24

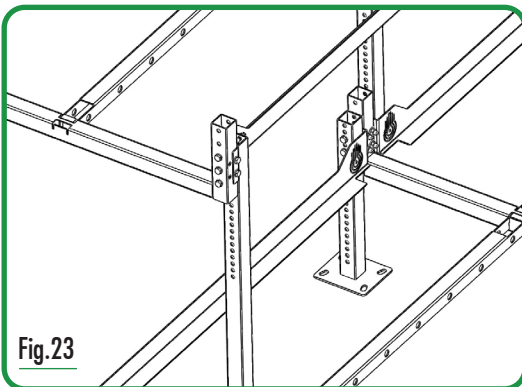

Fig. 23

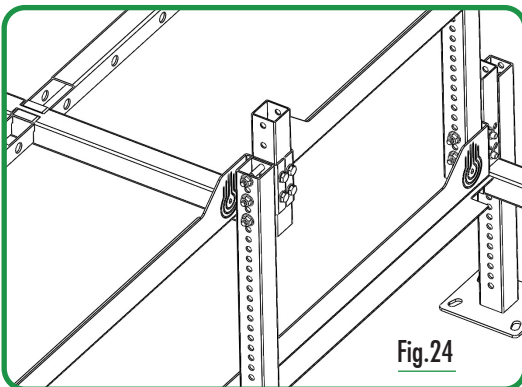

Fig. 24

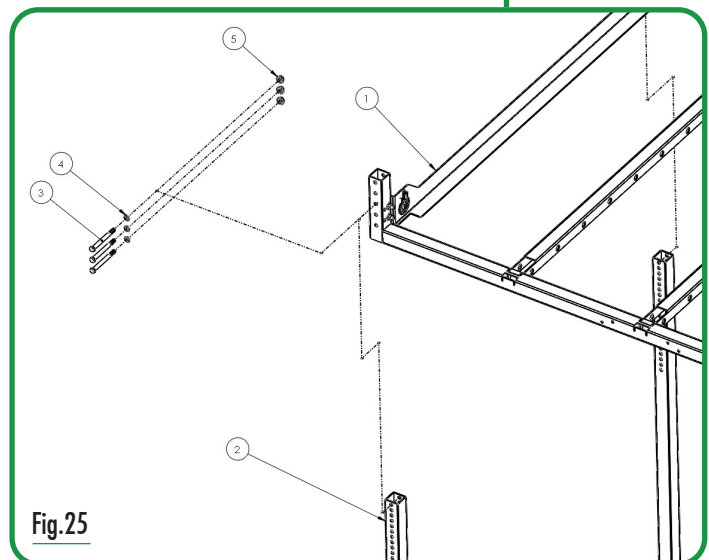

Fig. 25

# ASSEMBLING THIRD LEVEL FRAME

STEP 6

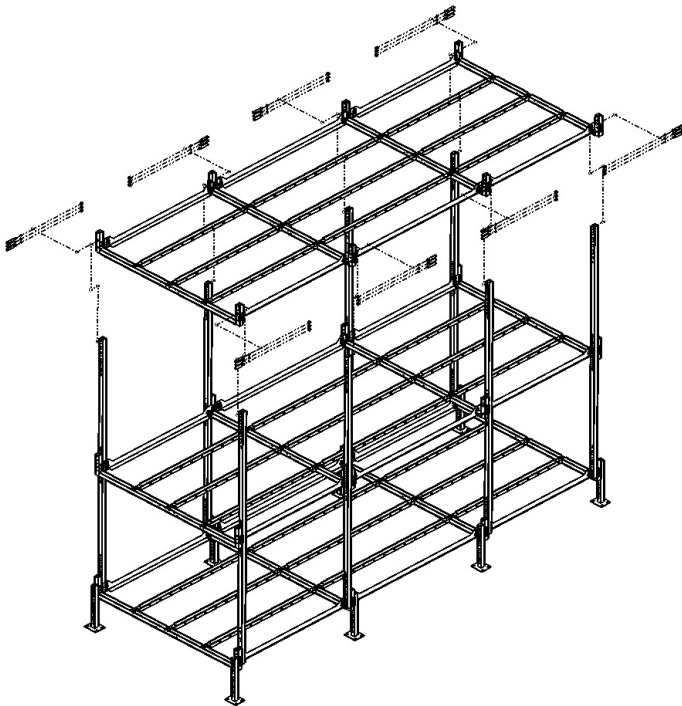

Fig. 26

6.1 Fix the pole to the first welded crossbar of the start frame of the third level with 3x bolt. ensure to include the side rail (1) correctly in the fixture as shown in Fig 26-27

6.2 Fix the pole to the second welded crossbar of the start frame of the third level with 3x bolt. ensure to include the side rail (1) correctly in the fixture as shown in Fig 26

6.3 Fix the pole internally to the first welded crossbar of the module frame of the third level with 3x bolt. ensure to include the side rail (1) correctly in the fixture as shown in Fig 26-30

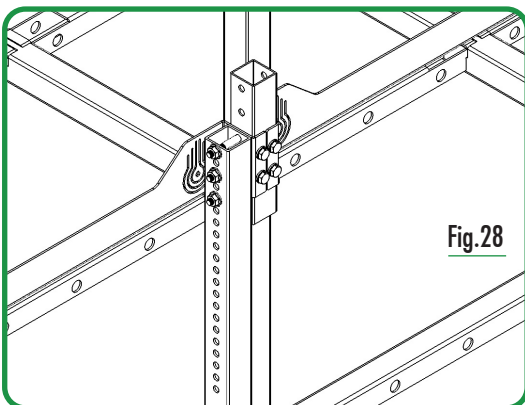

Fig. 28

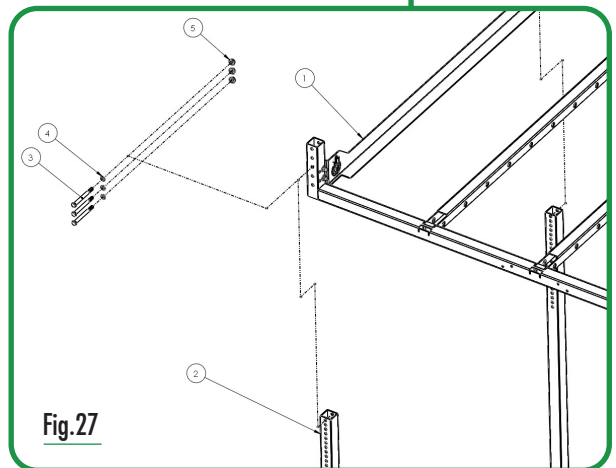

Fig. 27

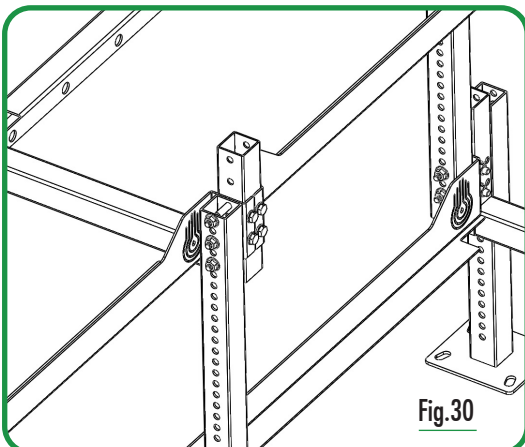

Fig. 30

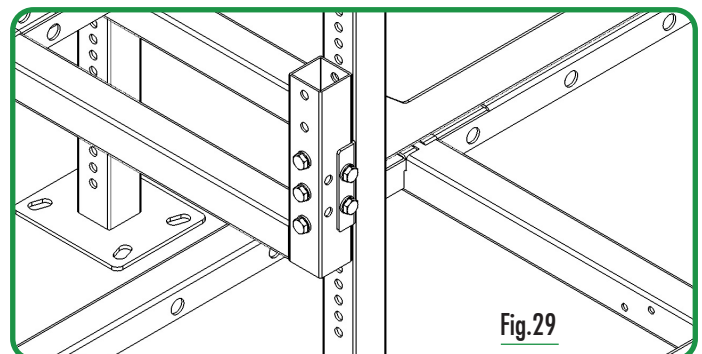

Fig. 29

# ASSEMBLING THE TRAYS ON THE FRAME

## STEP 7

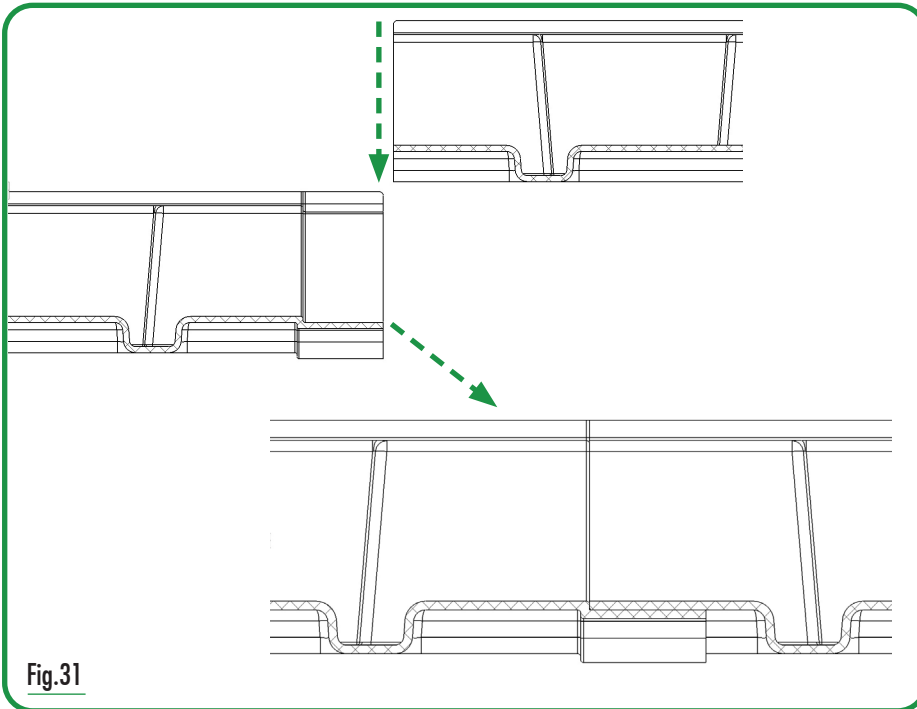

Fig.31

### NOTE

To guarantee a perfect drainage without spills it is **MANDATORY** to seal the trays with appropriate glue. You can use both silicon glue or a specific glue. Using specific glue will result in a flawless surface, but irreversible assembly of trays. Once glued, the trays will be welded together. Using silicon glue will result in a reduced appearance, but reversible assembly of trays. Upon need, you will be able to disassemble the trays and reuse them in other applications.

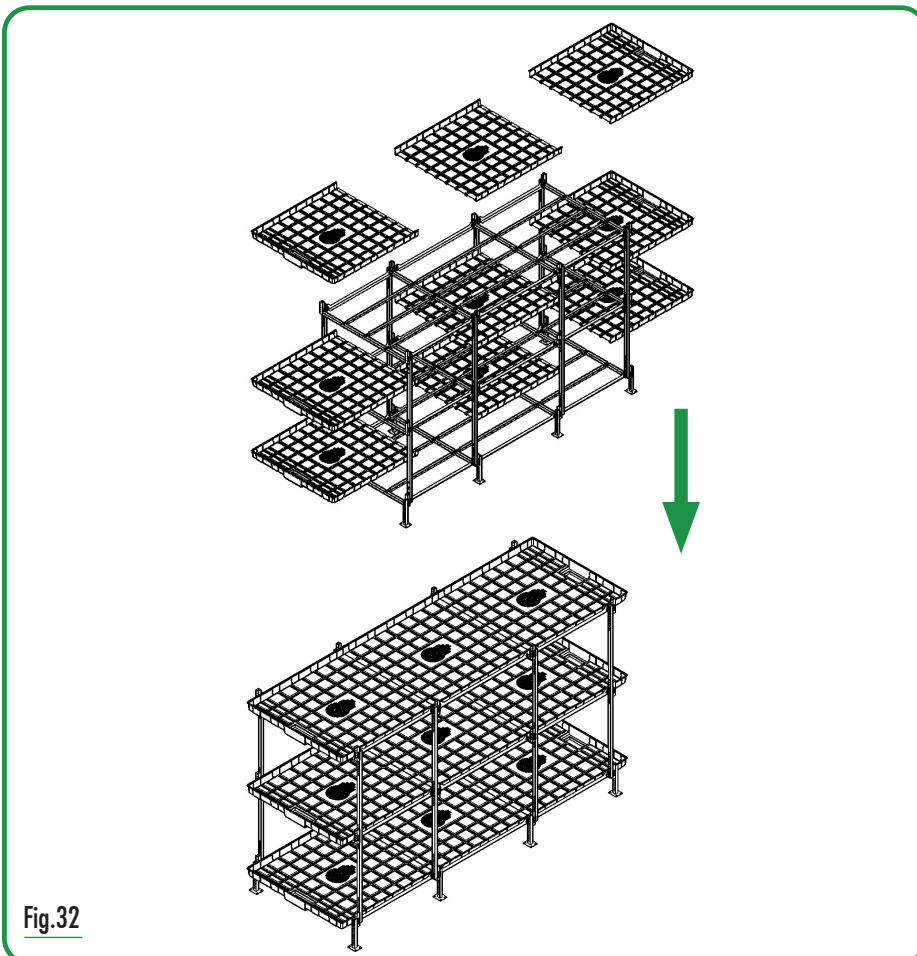

Fig.32

- 7.1 Enclose the trays in position as shown in figg.31-32.
- 7.2 Distribute uniformly the glue along the male edge of the start tray as shown in figg.31-32.
- 7.3 Position the female end of the module tray on the male edge of the start tray where you have distributed to glue as shown in figg.31-32.
- 7.4 Once positioned, it is suggested to place heavy weights along the coupling line of the two trays for at least 24 hours.
- 7.5 Repeat steps 7.2 – 7.3 – 7.4 for every additional module tray and finally for the end tray of your system

# ASSEMBLING THE NET POLE

STEP 8

## NOTE

Nets support poles are an optional accessory, purchasable separately. Our modular growing supports are designed with enclosures to install support poles every 120cm. For a perfect fastening of nets to the poles a pole every 240cm is usually enough. In the vertical supports the net posts are housed only on the upper level, for the lower levels the vertical uprights are also used as a support for fixing the nets.

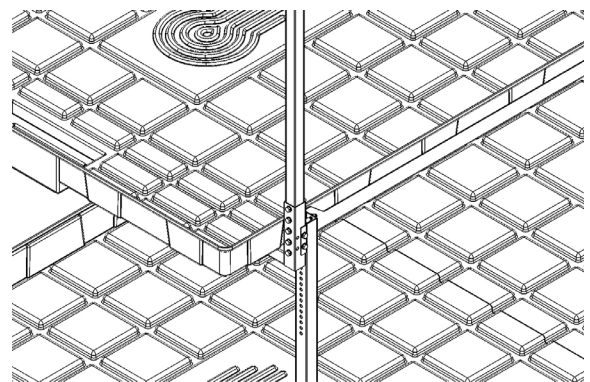
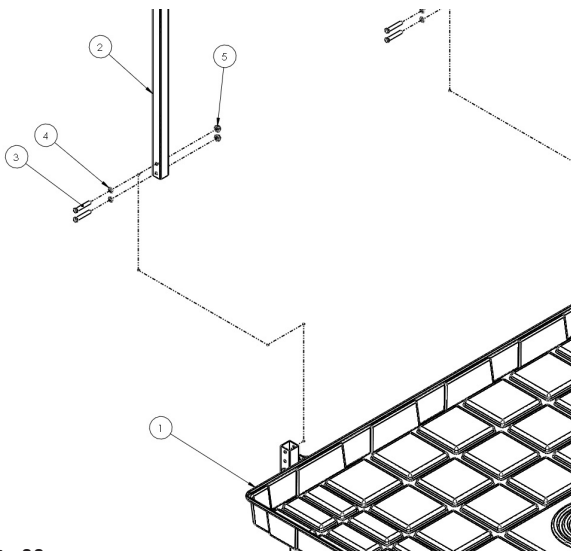
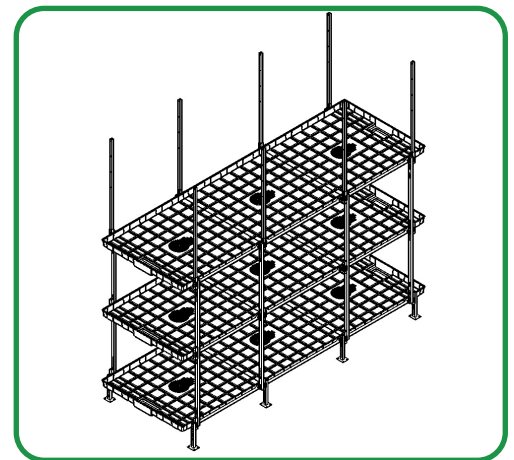
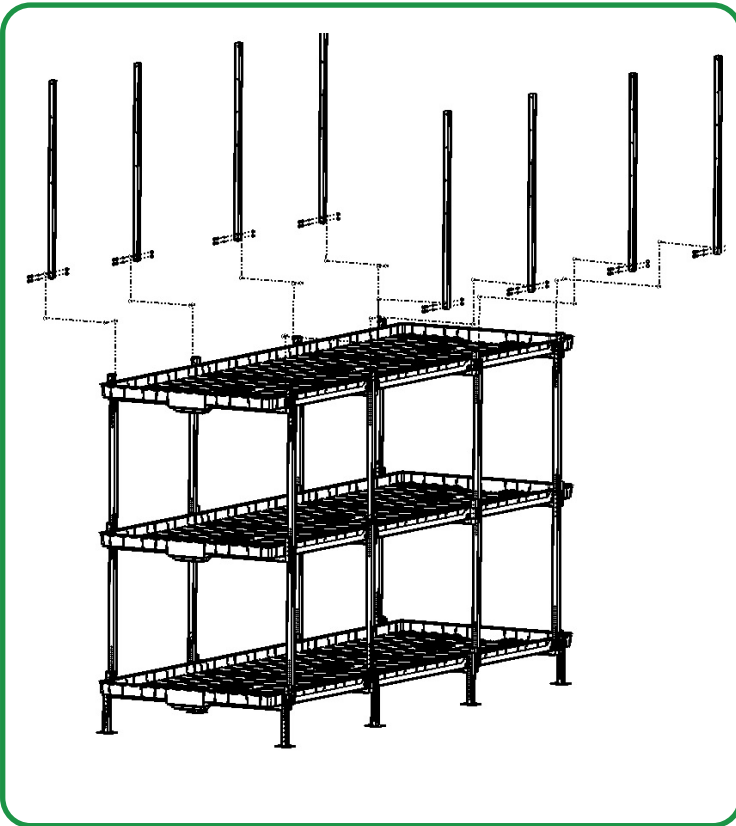

Fig.33

**8.1** Enclose the support pole in the specific enclosure found in the welded crossbar as shown in [fig.33](#)

**8.2** Fasten with 2 short screws in the specific holes found in the welded crossbar as shown in [fig.33](#)



---

EXCLUSIVELY DISTRIBUTED IN THE UNITED KINGDOM BY

**GreenMakers.**

[WWW.GREENMAKERS.CO.UK](http://WWW.GREENMAKERS.CO.UK)

[INFO@GREENMAKERS.CO.UK](mailto:INFO@GREENMAKERS.CO.UK)

020 3865 8182