

DIMENSIONI	DIMENSIONS	(mm, Kg)
Altezza	Height	1860
Larghezza	Width	598
Profondità	Depth	610
Peso netto	Net weight	90
CELLA INTERNA	INSIDE CELLA	
Altezza	Height	1727
Larghezza	Width	540
Profondità	Depth	465
PACKED DIMENSIONS	DIMENSIONI IMBALLO	(mm, Kg)
Altezza	Height	2000
Larghezza	Width	710
Profondità	Depth	710
Peso lordo	Gross Weight	102
CARATTERISTICHE GENERALI	MAIN FEATURES	
Colore standard	Standard color	Nero - Black
Tipo di compressore	Type of compressor	1/5 HP
Porta reversibile	Reversible door	NO
Termostato elettronico	Electronic thermostat	1
Piedi regolabili	Adjustable feet	2
Sistema refrigerante	Cool distribution system	Statico - Static
Sbrinamento automatico	Automatic Defrosting System	SI - YES
Scarico condensa	Condensate discharge	SI—YES
Luce led interna standard	Interior standard led light	WW 3000°k
Serratura	Lock	SI - YES
CARATTERISTICHE TECNICHE	TECHNICAL FEATURES	
Gas refrigerante	Cooling gas	R600a - Kg 0,074
Voltaggio	Voltage	220 - 230 V
Frequenza	Frequency	50 Hz
Potenza di assorbimento	Nominal input	240 W
Corrente nominale	Nominal current	1,61 A
Regolazione temperatura	Range temperature	4/18°C
Consumo energetico annuo	Annual energy consumption	kWh/annum 197
Classe Energetica	Energy class	G
Classe climatica	Climatic class	N
Pressione sonora	Noise Level	44 d BA
Volume lordo	Gross capacity	670
Volume netto	Net capacity	420

Progettato e prodotto in Italia

Designed and manufactured in Italy

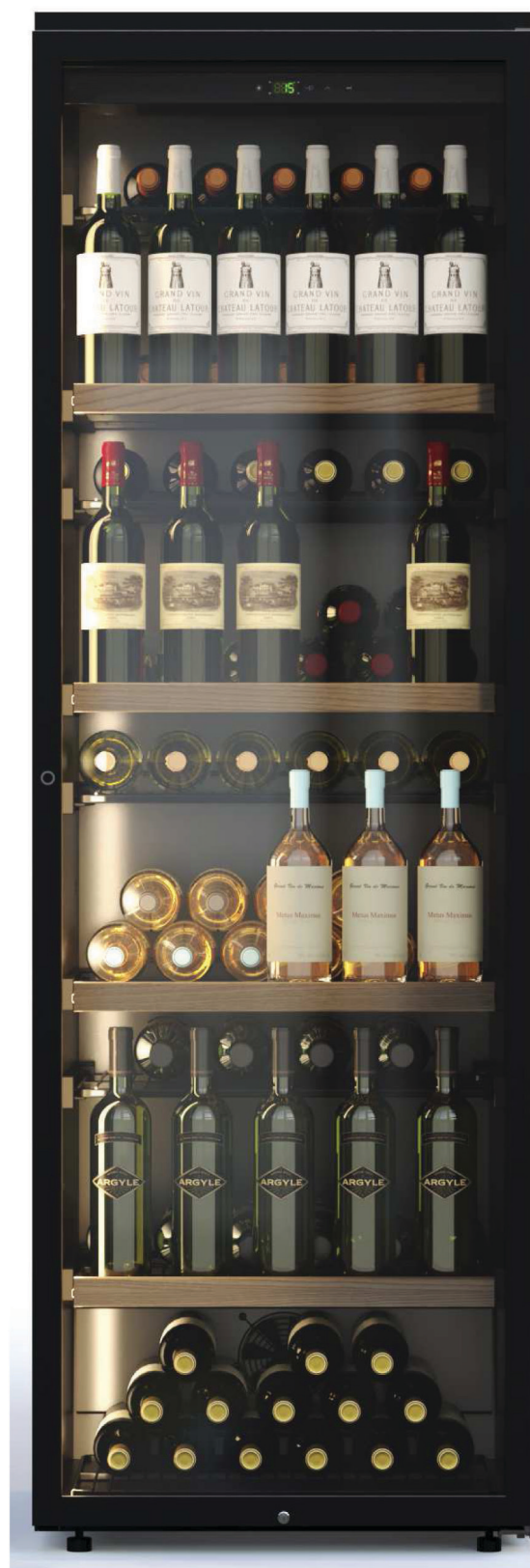

Dimensioni dettagliate - Detailed dimensions



Tolleranze con da UNI EN 22768-1, designazione "v"
Tolerance as UNI EN 22768-1, designation "v"

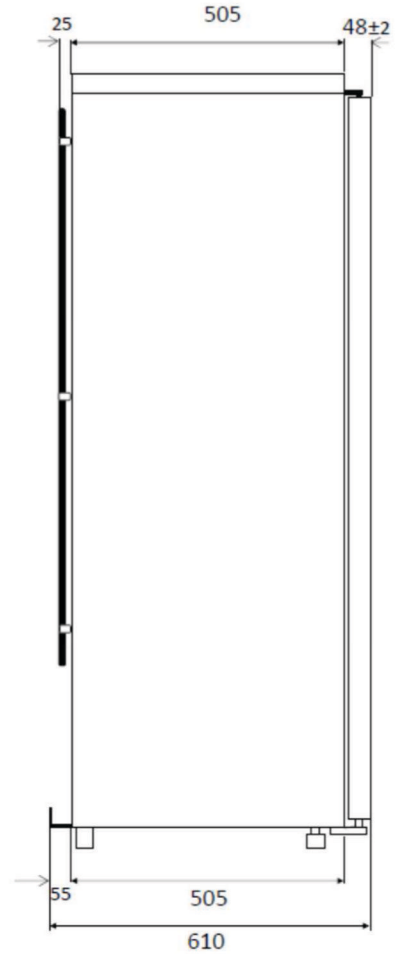

Tipi di allestimento interno - Setting up version

A - STANDARD

Ripiano fisso	Stock shelf	4
Ripiano scorrevole in legno	Sliding wooden shelf	
Ripiano intermedio	Half shelf	5
Capacità bt. 0,75 lt	Bottles capacity 0,75 lt	134

S - ORIZZONTALE

Ripiano fisso	Stock shelf	
Ripiano scorrevole in legno	Sliding wooden shelf	12
Ripiano intermedio	Half shelf	1
Capacità bt. 0,75 lt	Bottles capacity 0,75 lt	110

O - INCLINATA

Ripiano fisso	Stock shelf	6
Ripiano scorrevole in legno	Sliding wooden shelf	
Ripiano intermedio	Half shelf	7
Capacità bt. 0,75 lt	Bottles capacity 0,75 lt	104

L - VERTICALE

Ripiano fisso	Stock shelf	4
Ripiano scorrevole in legno	Sliding wooden shelf	
Ripiano intermedio	Half shelf	1
Capacità bt. 0,75 lt	Bottles capacity 0,75 lt	134

Versioni temperatura - Temperature Version

Versione Monotemperatura	Monotemperature version	4/18°C
Versione Multitemperatura	Multitemperature version	

Prove e regolamenti di riferimento - Reference tests and regulation

Test	Test	CB test; EMC test; Noise test; Energy test
Direttive di riferimento	Reference directives	2006/42/CE; 2014/30/UE; 2011/65/UE.

DIMENSIONI	DIMENSIONS	(mm, Kg)
Altezza	Height	1865
Larghezza	Width	600
Profondità	Depth	610
Peso netto	Net weight	100
CELLA INTERNA	INSIDE CELLA	UP / DOWN
Altezza	Height	940 / 733
Larghezza	Width	540 / 540
Profondità	Depth	465 / 465
PACKED DIMENSIONS	DIMENSIONI IMBALLO	(mm, Kg)
Altezza	Height	2000
Larghezza	Width	710
Profondità	Depth	710
Peso lordo	Gross Weight	112
CARATTERISTICHE GENERALI	MAIN FEATURES	
Colore standard	Standard color	Nero - Black
Tipo di compressore	Type of compressor	1/8 HPx2
Porta reversibile	Reversible door	NO
Termostato elettronico	Electronic thermostat	1
Piedi regolabili	Adjustable feet	2
Sistema refrigerante	Cool distribution system	Statico - Static
Sbrinamento automatico	Automatic Defrosting System	SI - YES
Scarico condensa	Condensate discharge	SI—YES
Luce led interna standard	Interior standard led light	WW 2800/3100°k
Serratura	Lock	SI - YES
CARATTERISTICHE TECNICHE	TECHNICAL FEATURES	
Gas refrigerante	Cooling gas	R134a Kg 0,075+0,070
Voltaggio	Voltage	220 - 230 V
Frequenza	Frequency	50 Hz
Potenza di assorbimento	Nominal input	240 W
Corrente nominale	Nominal current	1,61 A
Regolazione temperatura	Range temperature	6/18°C
Consumo energetico annuo	Annual energy consumption	kWh/annum 335
Classe Energetica	Energy class	C
Classe climatica	Climatic class	N
Pressione sonora	Noise level	45 d BA
Volume lordo	Gross capacity	670
Volume netto	Net capacity	410
Capienza di bottiglie 0,75 lt	Bottles capacity 0,75 lt	72+55

Progettato e prodotto in Italia

Designed and manufactured in Italy



Dimensioni dettagliate - Detailed dimensions

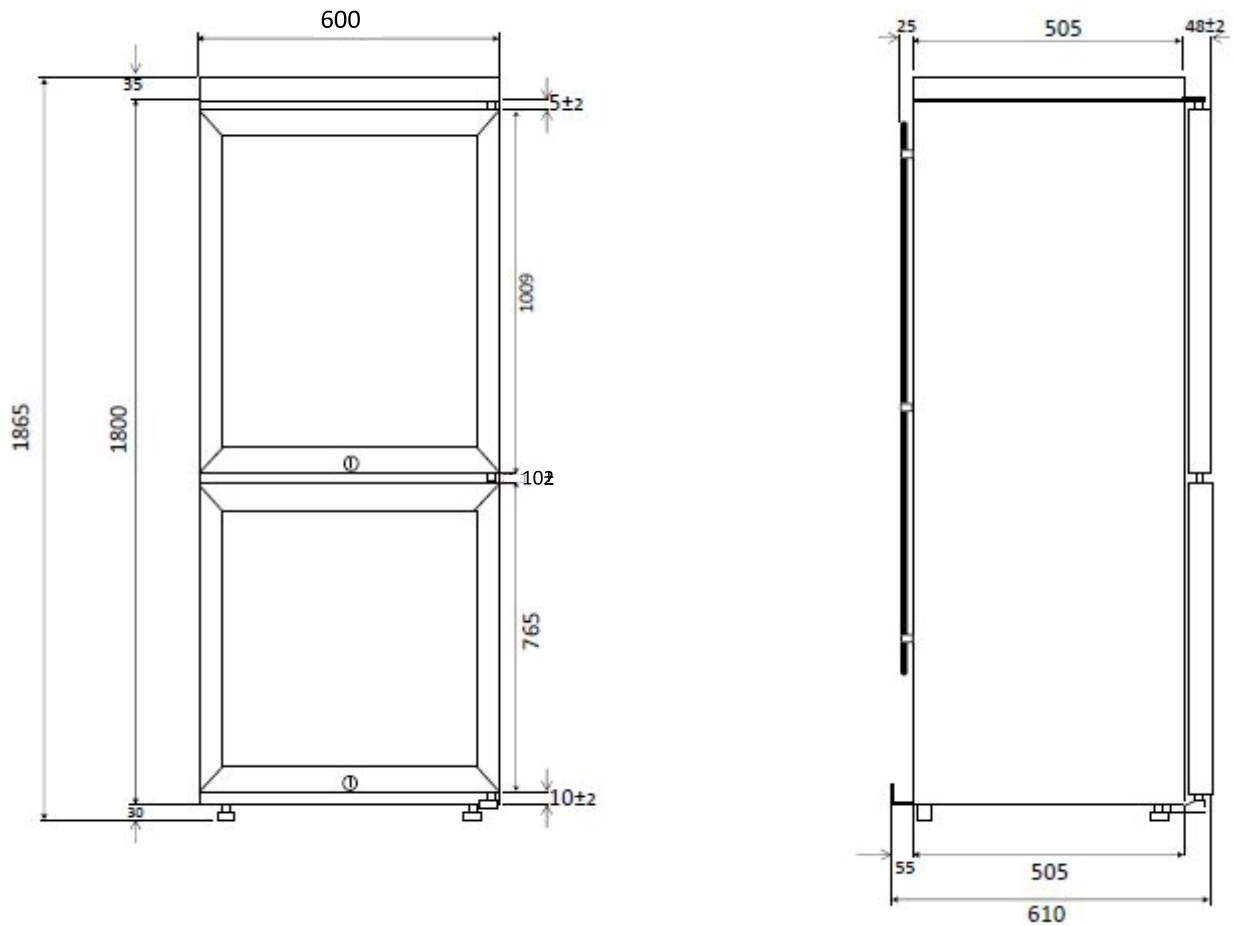

Tipi di allestimento interno - Setting up version



CELLA SUPERIORE - UPPER CELLAR / STANDARD

SALUMI / SALAMI

CELLA INFERIORE - LOWER CELLAR / STANDARD

FORMAGGI / CHEESE

Aste di supporto	Supporting poles	3	Ripiano scorrevole inox	SS Sliding shelf	2
Ripiano intermedio	Half shelf	1	Ripiano intermedio	Half shelf	1
Capacità Kg	Capacity Kg	60	Capacità Kg	Capacity Kg	40

Cella inferiore	Lower cellar		6/18°C
Cella superiore	Upper cellar		6/18°C

Certificazione e Norme di riferimento - Certifications and standard reference

Certificazioni	Certifications	CE; CB test; EMC test; Noise test; Energy test
Direttive di riferimento	Reference directives	2006/42/CE; 2014/30/UE; 2014/35/UE; 2012/19/UE; 2012/65/UE.
Regolamenti	Regulations	2016/2019/UE; 2019/2019/UE.