

Cantinetta Frigo Blck 8 bott.* SINGOLA TEMPERATURA

* tipo Bordolese da 0,75 Lt.

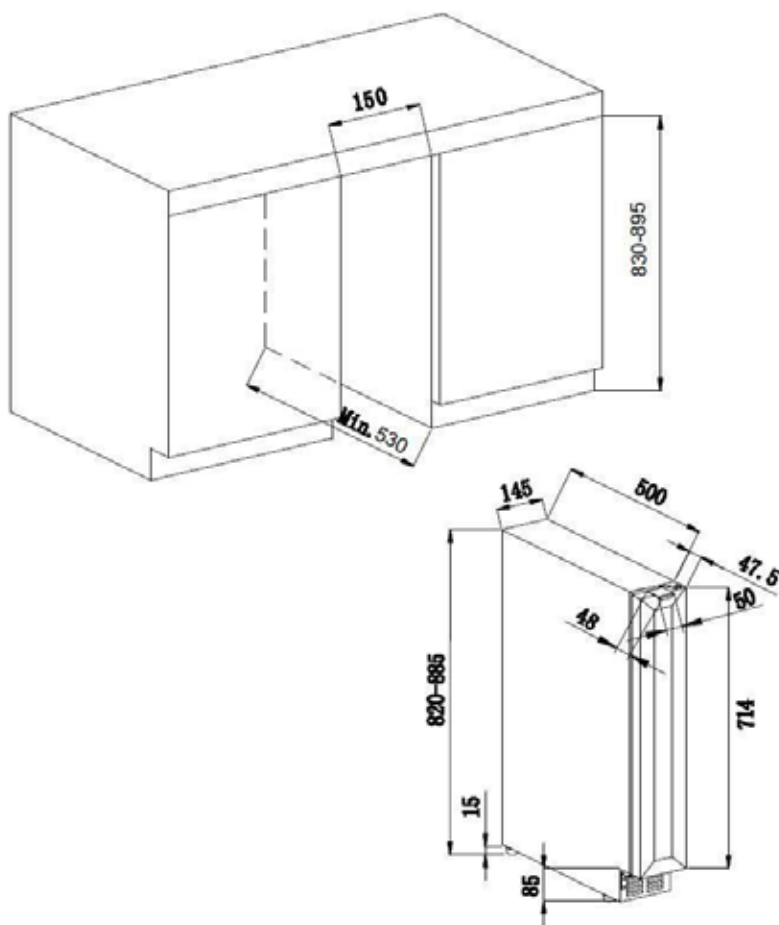

- . Installazione libera o ad Incasso a pavimento
- . Capacità 8 bottiglie*
- . Raffreddamento: Compressore
- . Temperatura Regolabile d'Uso: +5 a +20 ° C
- . Regolazione Elettronica
- . Termometro con Display Digitale bianco
- . Luci LED bianca con pulsante di accensione
- . Maniglia a scomparsa integrata nella parte superiore della cornice sotto bancone
- . Porta reversibile in triplo vetro anti-UV



Temperatura d'Esercizio: da 16° a 38°C

ATTREZZATURE INCLUSE

- . 6 Alloggi per bott.
- . 4 Piedini Regolabili (altezza 6,5 cm)
- . Sistema Antivibrante
- . Sbrinamento Automatico

CARATTERISTICHE TECNICHE

- . Classe energetica: G
- . Consumo elettrico annuale: 133 kWh
- . Classe climatica: N-ST
- . Rumorosità: 39 dB
- . Voltaggio: 220 - 240 V.
- . Potenza assorbita: 70 W.
- . Tipo di gas: R600a
- . Dimensioni (LxPxA cm): 14,5 x 54,8 x 82
- . Peso: 20 Kg

SICUREZZA

- . Allarmi Visivi e Sonori: avvisa quando è richiesta la tua attenzione
- . **Vinotag®**: applicazione gratuita per la gestione della cantina

Cellar Fridge Blck 8 bottles * SINGLE TEMPERATURE

* Calculated with 0.75 Lt. Bordeaux bottles.



- . Free-standing or recessed floor installation
- . Capacity 8 bottles *
- . Cooling: Compressor
- . Adjustable Temperature of Use: +5 to +20 ° C
- . Electronic Adjustment
- . Thermometer with white digital display
- . White LED lights with power button
- . Integrated retractable handle in the upper part of the frame under the counter
- . Reversible door in triple anti-UV glass

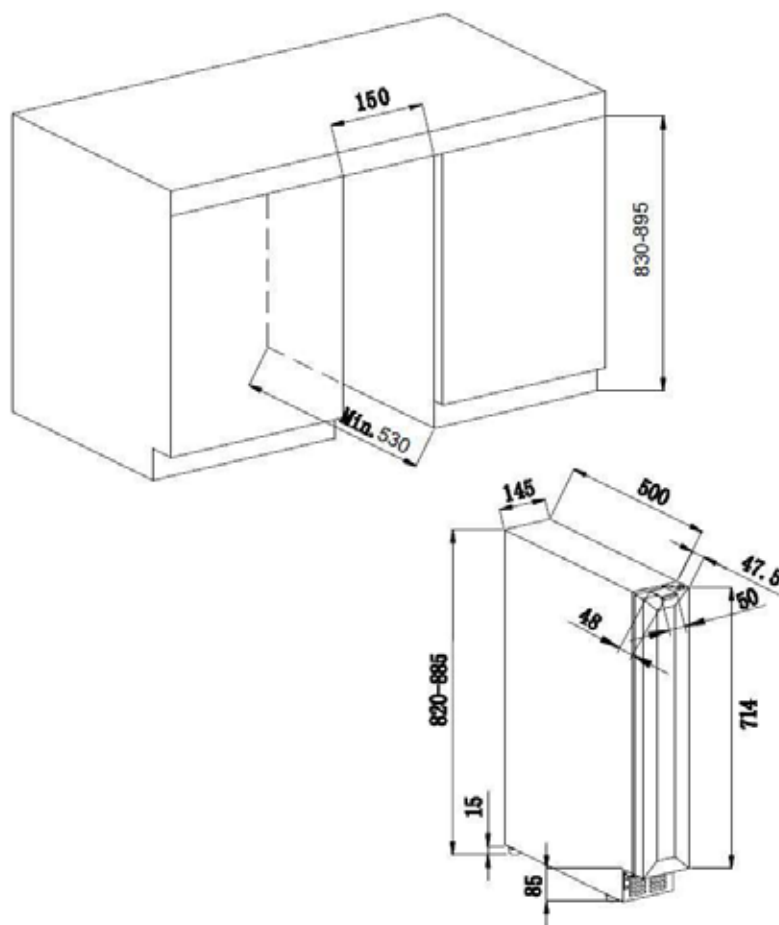

Ambient temperature: from 16 ° to 38 ° C

EQUIPMENT INCLUDED

- . 6 Accommodations per bottle
- . 4 Adjustable Feet (height 6.5 cm)
- . Anti-vibration system
- . Automatic defrost

TECHNICAL FEATURES

- . Energy class: G.
- . Annual electricity consumption: 133 kWh
- . Climate class: N-ST
- . Noise: 39 dB
- . Voltage: 220 - 240 V.
- . Power consumption: 70 W.
- . Gas type: R600a
- . Dimensions (WxDxH cm): 14.5 x 54.8 x 82
- . Weight: 20 Kg

SAFETY

- . Visual and Audible Alarms: warn when your attention is required
- . Vinotag®: free application for cellar management