

## Cantina Frigo incasso 53 bottiglie\* DOPPIA TEMPERATURA

\* tipo Bordolese da 0,75 Lt.

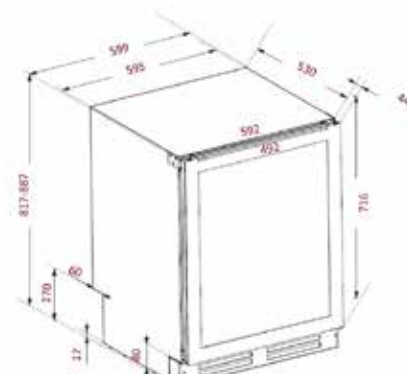

- . Colore Acciaio
- . Installazione Libera/incasso
- . Raffreddamento: Compressore
- . Temperatura Regolabile da  
Superiore: da 5° a 12°C / 16 Bott\*  
Inferiore: da 12°C a 20°C / 37 Bott\*
- . Porta in vetro temperato a 3 strati Anti-UV
- . Porta in Acciaio Inox
- . Maniglia a scomparsa integrata nella parte superiore
- . Regolazione Elettronica con display digitale
- . Luce LED bianca con pulsante di accensione
- . Porta reversibile

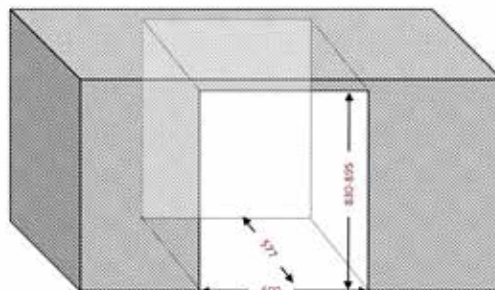

Temperatura d'Esercizio: da 16° a 32°C

### ATTREZZATURE INCLUSE

- . 4 ripiani scorrevoli in legno
- . 1 ripiano fisso in legno di presentazione
- . 4 Piedini Regolabili (altezza 7 cm)
- . Sistema Antivibrazione
- . Sbrinamento automatico

### CARATTERISTICHE TECNICHE

- . Classe Energetica: G
- . Consumo elettrico annuale: 157 kWh
- . Classe climatica: N
- . Rumorosità: 39 dB
- . Voltaggio: 220 - 240 V.
- . Potenza assorbita: 80 W.
- . Tipo di gas: R600a
- . Dimensioni (LxPxA cm): 59,5x57,4x81,7
- . Peso: 42 Kg

### SICUREZZA

- . Allarmi visivi e acustici: ti avvisa quando è richiesta la tua attenzione

### VINOTAG®

- . Applicazione gratuita per la gestione della cantina

## Built-In Wine Cellar 53 bottles \* DOUBLE TEMPERATURE

\* Calculated with 0.75 Lt. Bordeaux bottles.



- . Steel color
- . Free standing and built-under
- . Cooling: Compressor
- . Adjustable Temperature from  
Upper: from 5° to 12° C / 16 Bottles\*  
Lower: from 12° to 20° C / 37 Bottles \*
- . Anti-UV 3-layer tempered glass door
- . Stainless steel door
- . Integrated retractable handle in the upper part
- . Electronic regulation with digital display
- . White LED light with power button
- . Reversible door

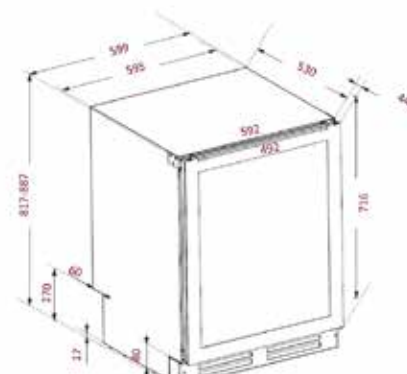
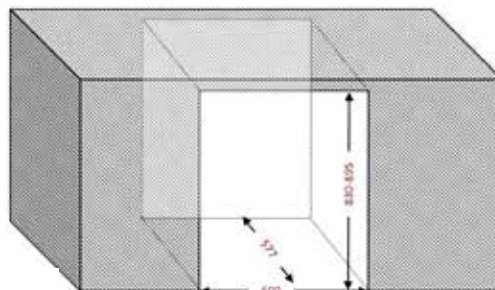

Ambient temperature: from 16° a 32°C

### EQUIPMENT INCLUDED

- . 4 sliding wooden shelves
- . 1 fixed shelf in presentation wood
- . 4 Adjustable Feet (height 7 cm)
- . Antivibration system
- . Automatic defrost

### TECHNICAL FEATURES

- . Energy Class: G
- . Annual electricity consumption: 157 kWh
- . Climate class: N
- . Noise: 39 dB
- . Voltage: 220 - 240 V.
- . Power consumption: 80 W.
- . Gas type: R600a
- . Dimensions (LxWxH cm): 59,5x57,4x81,7
- . Weight: 42 Kg

### SAFETY

- . Visual and audible alarms: alerts you when your attention is required

### VINOTAG®

- . Free application for the management of the cellar