

Cantinetta Frigo incasso 24 bottiglie* SINGOLA TEMPERATURA

* tipo Bordolese da 0,75 Lt.

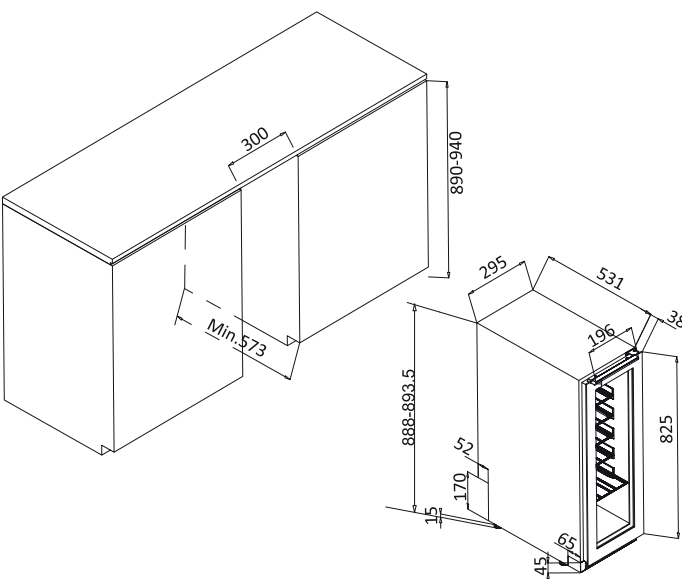

- . Colore Acciaio
- . Installazione Libera/incasso
- . Raffreddamento: Compressore
- . Temperatura Regolabile da 5° a 20°C
- . Porta in vetro temperato a 3 strati Anti-UV
- . Cornice porta in acciaio
- . Maniglia a scomparsa integrata nella parte superiore
- . Regolazione Elettronica con display digitale
- . Luce LED bianca con pulsante di accensione
- . Porta reversibile

Temperatura d'Esercizio: da 10° a 38°C

ATTREZZATURE INCLUSE

- . 1 ripiani in metallo scorrevole con frontalino in legno
- . 5 semiripiani in metallo con frontalino in legno
- . 4 Piedini Regolabili (altezza 5,5 cm)
- . Sistema Antivibrazione
- . Sbrinamento automatico

CARATTERISTICHE TECNICHE

- . Classe Energetica: F
- . Consumo elettrico annuale: 100 kWh
- . Classe climatica: SN-ST
- . Rumorosità: 38 dB
- . Voltaggio: 220 - 240 V.
- . Potenza assorbita: 60 W.
- . Tipo di gas: R600a
- . Dimensioni (LxPxA cm): 30x57x89 cm
- . Peso: 29 Kg

Fridge cellar 24 bottles * SINGLE TEMPERATURE

* Calculated with 0.75 Lt. Bordeaux bottles.

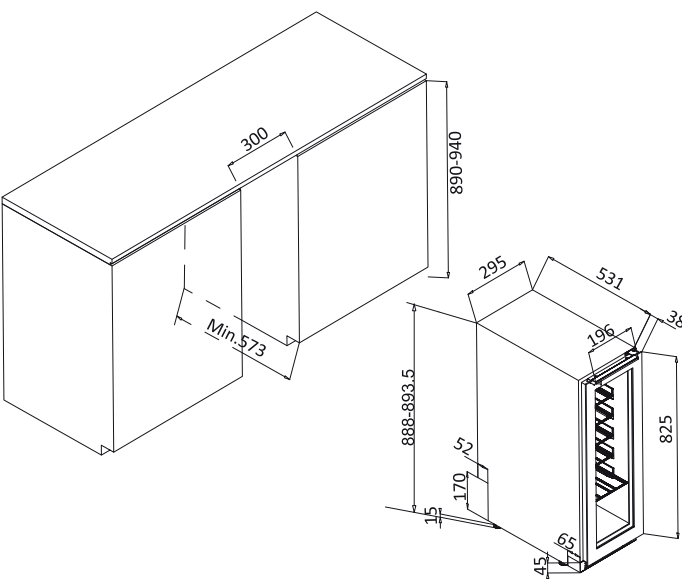

- . Steel color
- . Free-standing / recessed installation
- . Cooling: Compressor
- . Adjustable temperature from 5 ° to 20 ° C
- . Anti-UV 3-layer tempered glass door
- . Door frame in steel
- . Integrated retractable handle in the upper part
- . Electronic regulation with digital display
- . White LED light with power button
- . Reversible door

Ambient temperature: from 10° to 38°C

EQUIPMENT INCLUDED

- . 1 sliding metal shelves with wooden front panel
- . 5 half-shelves in metal with wooden front panel
- . 4 Adjustable Feet (height 5.5 cm)
- . Antivibration system. Automatic defrost

TECHNICAL FEATURES

- . Energy Class: F
- . Annual electricity consumption: 100 kWh
- . Climate class: SN-ST
- . Noise: 38 dB
- . Voltage: 220 - 240 V.
- . Power consumption: 60 W.
- . Gas type: R600a
- . Dimensions (LxWxH cm): 30x57x89 cm
- . Weight: 29 Kg