

Cantinetta Frigo Incasso 97 bottiglie* TRIPLA TEMPERATURA

* tipo Bordolese da 0,75 Lt.

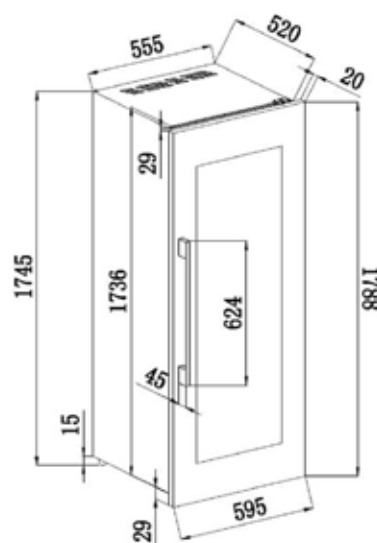
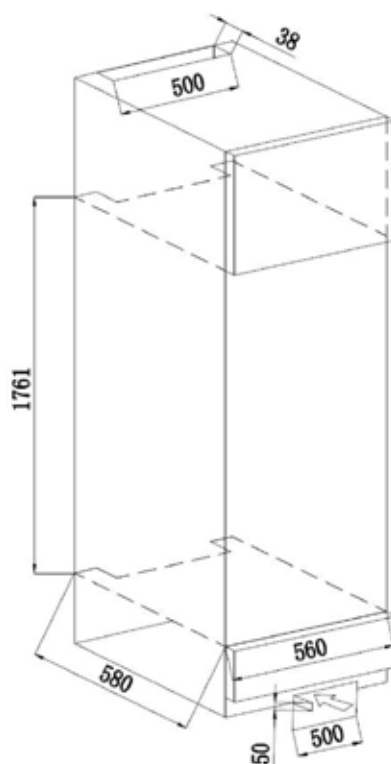
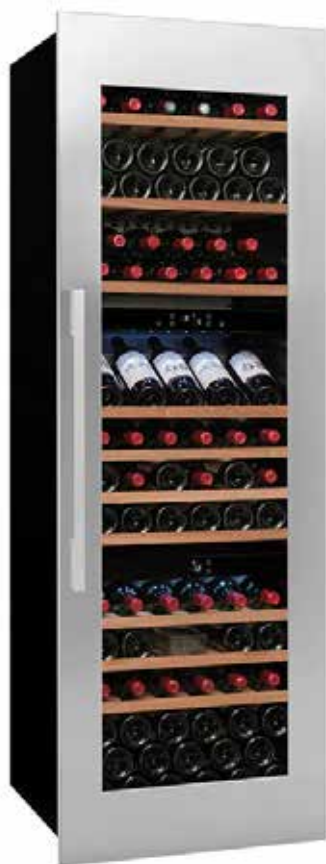

Temperatura d'Esercizio: da 16° a 32°C

ATTREZZATURE INCLUSE

- . 9 Ripiani scorrevoli in Legno
- . 1 Ripiano di Presentazione scorrevole
- . 4 Piedini Regolabili (altezza 3 cm)
- . Sistema Antivibrazione

CARATTERISTICHE TECNICHE

- . Classe energetica: G
- . Consumo elettrico annuale: 162 kWh
- . Classe climatica: N
- . Rumorosità: 38 dB
- . Voltaggio: 220 - 240 V.
- . Potenza assorbita: 165 W.
- . Tipo di gas: R600a
- . Dimensioni (LxPxA cm): 59,5 x 55,7 x 178,8
- . Peso: 106 Kg

VINOTAG®

- . Applicazione gratuita per la gestione della tua cantina.

Cellar Fridge built-in column 97 bottles* TRIPLE TEMPERATURE

* tipo Bordolese da 0,75 Lt.

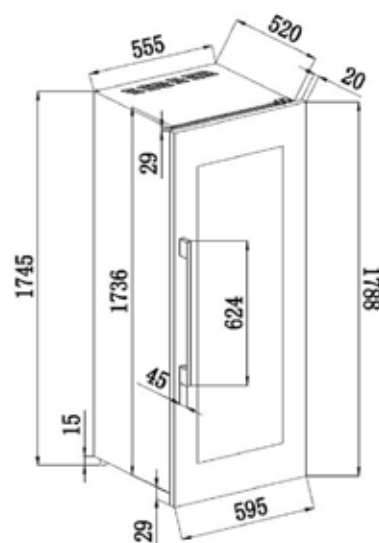
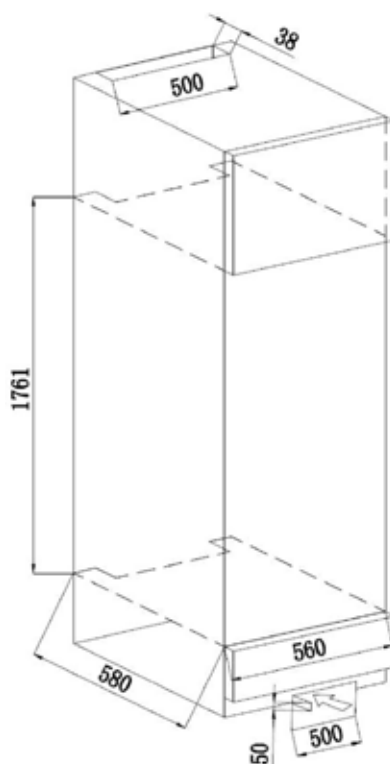

Ambient temperature: from 16° a 32°C

EQUIPMENT INCLUDED

- . 9 Sliding wooden shelves
- . 1 Presentation Shelf sliding
- . 4 Adjustable Feet (height 3 cm)
- . Antivibration system

TECHNICAL FEATURES

- . Energy class: G.
- . Annual electricity consumption: 162 kWh
- . Climate class: N
- . Noise: 38 dB
- . Voltage: 220 - 240 V.
- . Power consumption: 165 W.
- . Gas type: R600a
- . Dimensions (LxWxH cm): 59.5 x 55.7 x 178.8
- . Weight: 106 Kg

VINOTAG®

- . Free application for the management of the cellar