

RH Series

Single Cartridge Filter Housings with Ring Nut Closure



- Designed for industrial and commercial filter applications
- Heavy duty construction for maximum durability
- Various materials of construction for a wide range of process requirements
 - 316L stainless steel
 - Brass head with 304L Stainless Steel body
- Accepts Double Open End (DOE) and Single Open End (SOE) 213 Internal O-ring
- Available with 1/2", 3/4" and 1" in-line connections for easy installation.
- Ring nut closure for quick cartridge change outs
- Spring loaded knife edge seal provides positive sealing for variable length cartridges
- Supplied with mounting bracket kit and wrench
- Numerous gasket options for compatibility with most fluids

Applications

Water	Chemicals
Food & Beverage	Electronics
Oil	Inks / Paints / Coatings
Coolants	Pulp & Paper

Specifications & Operating Parameters

Maximum Operating Pressure

300 psig (20.7 bar) @ 200°F (93°C)

Connections

Inlet /Outlet: 1/2", 3/4" or 1" FNPT

Optional: BSPT, BSPP, Sanitary Ferrules

Drain: RHS - 1/4" NPT Plug

RHB - 1/4" NPT Petcock

Materials of Construction

Head / Shell: RHS 316L SS / 316L SS

RHB Brass / 304L Stainless Steel

Drain: RHS - 316L SS Plug

RHB - Brass Petcock

Ring: RHS -Nickel Plated Brass

RHB - Brass

Gaskets

Buna N (FDA Grade)

Optional: EPR, Silicone, Viton

Cartridge Type

DOE and SOE 213 Internal O-ring

Custom Options

- Gauge Ports

- Vent Port with Vent Screw

See Ordering Guide for complete selection of options

MODEL	QUANTITY (LENGTH) OF CARTRIDGES	MAXIMUM FLOW RATE* GPM (LPM)	MAXIMUM DIAMETER CARTRIDGE	DRAIN SIZE	DIMENSIONS	
					A	B
RH-39	1 (4 7/8 - 5")	3 1/2 (13.3)	2 3/4"	1/4"	8 9/16" (21.7 cm)	7 3/4" (19.7 cm)
RH-78	1 (9 3/4 - 10")	7 (26.5)	2 3/4"	1/4"	13 9/16" (34.4 cm)	12 3/4" (32.4 cm)
RH-80	1 (19 1/2 - 20")	14 (53)	2 3/4"	1/4"	23 9/16" (59.8 cm)	22 3/4" (57.8 cm)
RH-90	1 (30")	21(79.5)	2 3/4"	1/4"	33 9/16" (85.2 cm)	32 3/4" (83.2 cm)

* Based upon 7 gpm (26.5 lpm) per 10" cartridge length with a 25 micron wound cartridge at 2 PSID clean and a viscosity of 1 cps. Flow rates are guidelines only. Actual flow rates are based upon fluid, viscosity, cartridge type, micron ratings and other factors

Dimensions

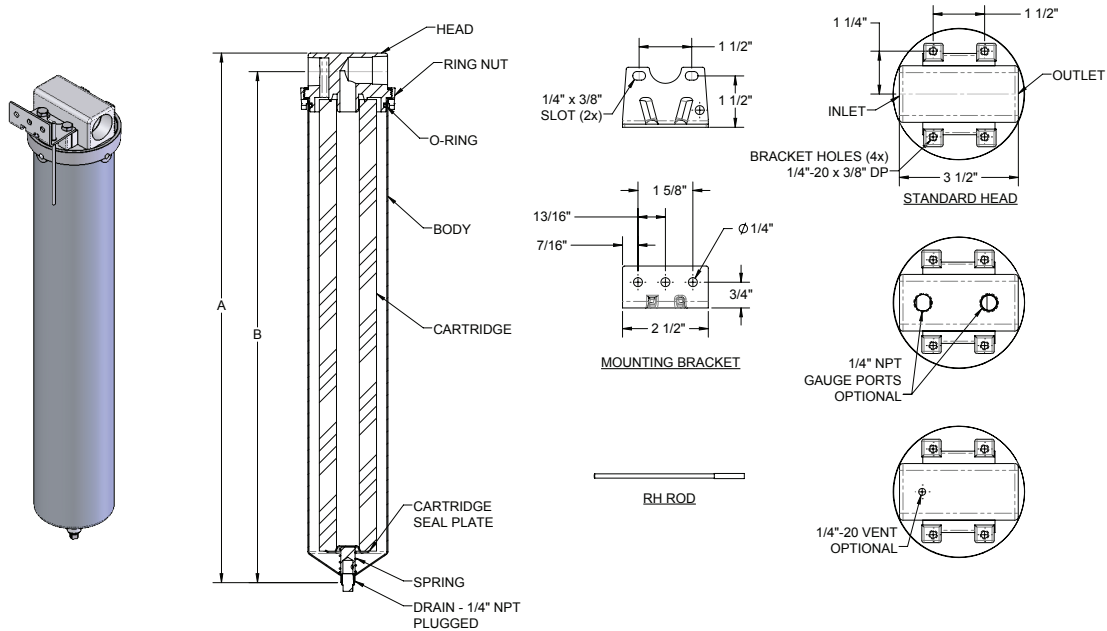

Ordering Guide (Example: RHS-786A-E)

RH	S	-	78	6A	-	-	B
MODEL	MATERIAL		CARTRIDGE LENGTH	PIPE SIZE FNPT		OPTIONS	GASKET
RH	S = 316L Stainless Steel with Stainless Steel Plug B = Brass Head with 304L Stainless Steel Sump and Nickel Plated Brass Ring Nut and Brass Petcock		39 = 4 7/8-5" 78 = 9 3/4-10" 80 = 19 1/2-20" 90 = 29 1/2 -30"	4 = 1/2" 6 = 3/4" 8 = 1"		Blank = None BSP = BSP thread 1TC = 1" Ferrules 150 psi GP4 = 1/4" Gauge Ports Vent = Vent Screw	B = Buna N (Standard) E = EPR S = Silicone V = Viton

Customization

Housings may be customized to meet your precise requirements. Contact Shelco's technical support staff or your distributor for more information.