



The Ideal Solution for Dependable Vortex Mixing of Microplates

OHAUS Microplate Vortex Mixers are perfect for mixing microplates throughout the speed range. All models are designed for continuous-duty use in the lab. Digital models offer a timer and exact speed control for applications that demand repeatable results and non-digital variable speed models are an economical alternative. The high-speed and small orbit of these mixers make them optimal for effectively mixing microplates.

Standard Features:

- Safe to mix at high speeds - the innovative locking design of the microplate accessories allows these mixers to safely operate throughout the entire speed range.
- These mixers utilize a high quality German-manufactured motor allowing for reliable, continuous-duty operation at any speed.
- Robust digital and non-digital models offer effective speed control from low rpm for gentle shaking to high-speed mixing for vigorous vortexing of samples.

Microplate Vortex Mixers

Model	VXMPAL	VXMPDG
Control	Analog	Digital
Speed Range	On Mode, 300 rpm – 2500 rpm, Touch Mode, 300 rpm – 3500 rpm	
Orbit	0.1 in. / 3.5 mm	
Duty Rating	Continuous	
Capacity	2 microplates	
Working Environment	39 °F – 104 °F, 20% – 85% RH*, non-condensing / 4 °C – 40 °C, 20% – 85% RH*, non-condensing	
Power	120V, 0.25A, 50/60Hz	
Power Consumption	30 W	
Dimensions (W × L × H)	5.4 × 10.5 × 4.5 in. / 137 × 266 × 114 mm	
Net Weight	11.7 lb / 5.3 kg	

*Relative Humidity

Other Standard Features and Equipment

Detachable 3-wire cord and plug (included), single microplate adapter and cup head (included)

Compliance

- **Product Safety:** CAN/CSA C22.2 61010-1, CAN/CSA C22.2 61010-2-051, UL 61010-1
- **Electromagnetic Compatibility:** ICES-003 Class A, FCC Part 15 Class A
- **Compliance Marks:** TÜV SÜD

Accessories

Cup Head, VXHD and VXMP Vortex Mixers30400210

Double Microplate Holder30400213

Single Microplate Holder30400215

Dimensions

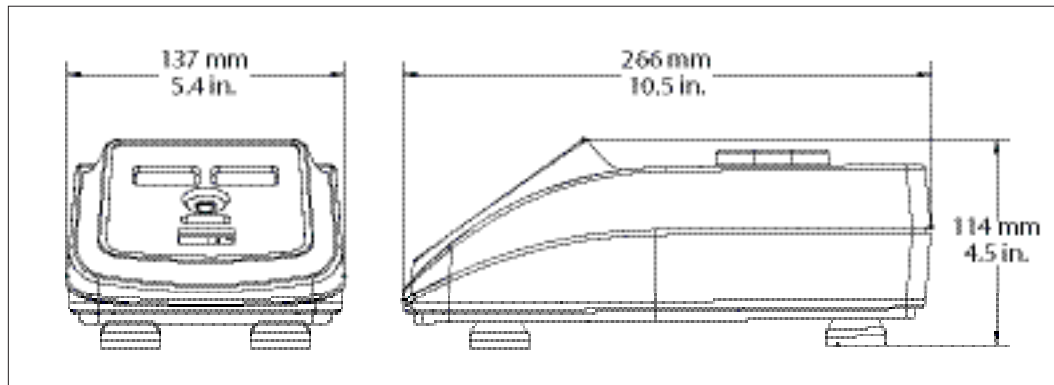

ERE INC
8605 rue Champ d'Eau
St. Leonard QC, H1P 3B8
Canada
Tel: (514) 326-8852
Fax: (514) 326-8961
www.ereinc.com

*The management system
governing the manufacture
of this product is
ISO 9001:2015 certified.*