

	<h1>Product Specification</h1>	Specification Number	A384-320
		Revision	01

Part No. A384-320

Description Drum Trolley

Material of Construction: Frame: 304 stainless steel
Wheel Mounts: 304 stainless steel
Wheels: Polyamide

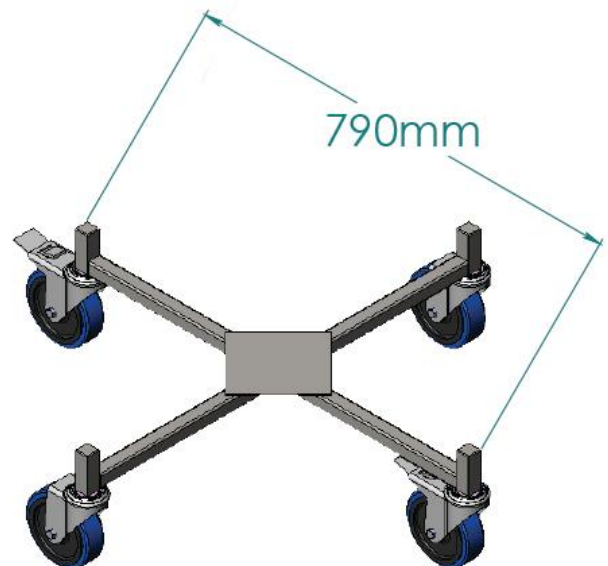

Method of Construction: Frame - welded

Surface Finish: Better than 0.8 microns Ra

Max. Frame Width: 790mm

Deck Height 160mm

Nominal Weight: 8.45kg

Specification Approved By:	Signature: 	Name: Kuldeep Flora Position: Quality Manager Date: 9-Jul-19
Page 1 of 1	Sampling Systems Ltd. 4-5 Forge Mills Park, Station Road, Coleshill. Warwickshire. B46 1JH. UK. Tel: +44(0)1675 466992 Email: info@sampling.com Web: www.sampling.com	